

HIGH-SPEED RAIL-TO-RAIL OUTPUT VIDEO AMPLIFIERS

FEATURES

- **High Speed**
 - 100 MHz Bandwidth (–3 dB, G= 2)
 - 900 V/ μ s Slew Rate
- **Excellent Video Performance**
 - 50 MHz Bandwidth (0.1 dB, G = 2)
 - 0.007% Differential Gain
 - 0.007° Differential Phase
- **Rail-to-Rail Output Swing**
 - $V_O = -4.5 / 4.5$ ($R_L = 150 \Omega$)
- **High Output Drive, $I_O = 100$ mA (typ)**
- **Ultralow Distortion**
 - HD2 = –78 dBc ($f = 5$ MHz, $R_L = 150 \Omega$)
 - HD3 = –85 dBc ($f = 5$ MHz, $R_L = 150 \Omega$)
- **Wide Range of Power Supplies**
 - $V_S = 3$ V to 15 V

APPLICATIONS

- Video Line Driver
- Imaging
- DVD / CD ROM
- Active Filtering
- General Purpose Signal Chain Conditioning

VIDEO DRIVE CIRCUIT

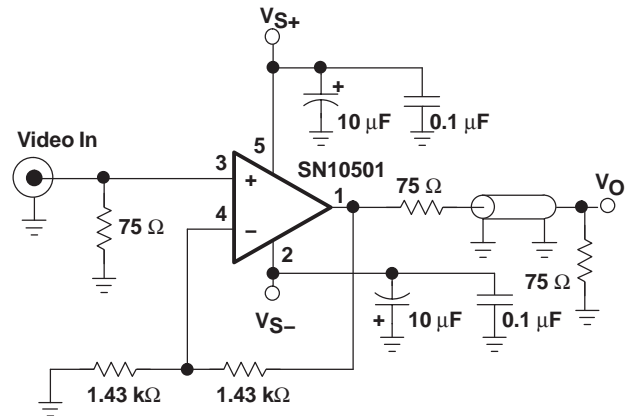

DESCRIPTION

The SN1050x family is a set of rail-to-rail output single, dual, and triple low-voltage, high-output swing, low-distortion high-speed amplifiers ideal for driving data converters, video switching, or low distortion applications. This family of voltage feedback amplifiers can operate from a single 15-V power supply down to a single 3-V power supply while consuming only 14 mA of quiescent current per channel. In addition, the family offers excellent ac performance with 100-MHz bandwidth, 900-V/ μ s slew rate and harmonic distortion (THD) at –78 dBc at 5 MHz.

DEVICE	DESCRIPTION
SN10501	Single
SN10502	Dual
SN10503	Triple

FREQUENCY RESPONSE

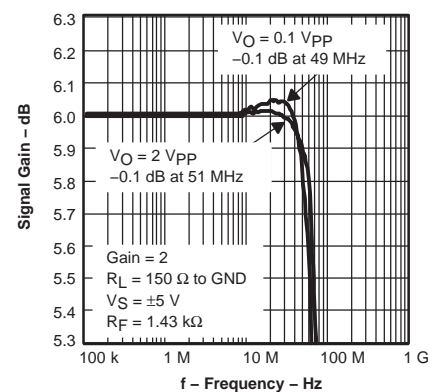

Please be aware that an important notice concerning availability, standard warranty, and use in critical applications of Texas Instruments semiconductor products and disclaimers thereto appears at the end of this data sheet.

ABSOLUTE MAXIMUM RATINGS

over operating free-air temperature range unless otherwise noted⁽¹⁾

	UNIT
Supply voltage, V_S	18 V
Input voltage, V_I	$\pm V_S$
Output current, I_O ⁽²⁾	150 mA
Differential input voltage, V_{ID}	4 V
Continuous power dissipation	See Dissipation Rating Table
Maximum junction temperature, T_J ⁽³⁾	150°C
Maximum junction temperature, continuous operation, longterm reliability, T_J ⁽⁴⁾	125°C
Operating free-air temperature range, T_A	-40°C to 85°C
Storage temperature range, T_{stg}	-65°C to 150°C
Lead temperature 1,6 mm (1/16 inch) from case for 10 seconds	300°C

- Stresses above these ratings may cause permanent damage. Exposure to absolute maximum conditions for extended periods may degrade device reliability. These are stress ratings only, and functional operation of the device at these or any other conditions beyond those specified is not implied.
- The SN1050x may incorporate a PowerPAD on the underside of the chip. This acts as a heatsink and must be connected to a thermally dissipative plane for proper power dissipation. Failure to do so may result in exceeding the maximum junction temperature which could permanently damage the device. See TI technical brief SLMA002 and SLMA004 for more information about utilizing the PowerPAD thermally enhanced package.
- The absolute maximum temperature under any condition is limited by the constraints of the silicon process.
- The maximum junction temperature for continuous operation is limited by package constraints. Operation above this temperature may result in reduced reliability and/or lifetime of the device



This integrated circuit can be damaged by ESD. Texas Instruments recommends that all integrated circuits be handled with appropriate precautions. Failure to observe proper handling and installation procedures can cause damage.

ESD damage can range from subtle performance degradation to complete device failure. Precision integrated circuits may be more susceptible to damage because very small parametric changes could cause the device not to meet its published specifications.

PACKAGE DISSIPATION RATINGS

PACKAGE	Θ_{JC} (°C/W)	Θ_{JA} ⁽¹⁾ (°C/W)	POWER RATING ⁽²⁾	
			$T_A \leq 25^\circ\text{C}$	$T_A = 85^\circ\text{C}$
DBV (5)	55	255.4	391 mW	156 mW
D (8)	38.3	97.5	1.02 W	410 mW
D (14)	26.9	66.6	1.5 W	600 mW
DGK (8)	54.2	260	385 mW	154 mW
DGN (8)	4.7	58.4	1.71 W	685 mW
PWP (14)	2.07	37.5	2.67 W	1.07 W

- This data was taken using the JEDEC standard High-K test PCB.
- Power rating is determined with a junction temperature of 125°C. This is the point where distortion starts to substantially increase. Thermal management of the final PCB should strive to keep the junction temperature at or below 125°C for best performance and long term reliability.

RECOMMENDED OPERATING CONDITIONS

		MIN	MAX	UNIT
Supply voltage, (V_{S+} and V_{S-})	Dual supply	± 1.35	± 9	V
	Single supply	2.7	18	
Input common-mode voltage range		$V_{S-} + 1.1$	$V_{S+} - 1.1$	V

PACKAGE/ORDERING INFORMATION

TEMPERATURE	PACKAGED DEVICES			PACKAGE TYPE	TRANSPORT MEDIA, QUANTITY
	SINGLE	DUAL	TRIPLE		
-40°C to 85°C	SN10501DBVT	---	---	SOT-23-5	Tape and Reel, 250
	SN10501DBVR	---	---	SOT-23-5	Tape and Reel, 3000
	SN10501DGK	SN10502DGK	---	MSOP-8	Rails, 75
	SN10501DGKR	SN10502DGKR	---	MSOP-8	Tape and Reel, 2500
	SN10501DGN	SN10502DGN	---	MSOP-8-PP	Rails, 75
	SN10501DGNR	SN10502DGNR	---	MSOP-8-PP	Tape and Reel, 2500
	SN10501D	SN10502D	SN10503D	SOIC	Rails, 75
	SN10501DR	SN10502DR	SN10503DR	SOIC	Tape and Reel, 2500
	---	---	SN10503PWP	TSSOP-14-PP	Rails, 75
	---	---	SN10503PWPR	TSSOP-14-PP	Tape and Reel, 2000

ELECTRICAL CHARACTERISTICS

$V_S = \pm 5\text{ V}$, $R_L = 150\ \Omega$, and $G = 2$ unless otherwise noted

PARAMETER	TEST CONDITIONS	TYP	OVER TEMPERATURE				UNITS	MIN/ MAX
		25°C	25°C	0°C to 70°C	-40°C to 85°C			
AC PERFORMANCE								
Small signal bandwidth	$G = 1$, $V_O = 100\text{ mVpp}$	170					MHz	Typ
	$G = 2$, $V_O = 100\text{ mVpp}$, $R_f = 1\text{ k}\Omega$	100					MHz	Typ
	$G = 10$, $V_O = 100\text{ mVpp}$, $R_f = 1\text{ k}\Omega$	12					MHz	Typ
0.1 dB flat bandwidth	$G = 2$, $V_O = 100\text{ mVpp}$, $R_f = 1.43\text{ k}\Omega$	50					MHz	Typ
Gain bandwidth product	$G > 10$, $f = 1\text{ MHz}$, $R_f = 1\text{ k}\Omega$	120					MHz	Typ
Full-power bandwidth ⁽¹⁾	$G = 2$, $V_O = \pm 2.5\text{ Vpp}$	57					MHz	Typ
Slew rate	$G = 2$, $V_O = \pm 2.5\text{ Vpp}$	900					V/ μs	Min
Settling time to 0.1%	$G = -2$, $V_O = \pm 2\text{ Vpp}$	25					ns	Typ
Settling time to 0.01%	$G = -2$, $V_O = \pm 2\text{ Vpp}$	52					ns	Typ
Harmonic distortion	$G = 2$, $V_O = 2\text{ Vpp}$, $f = 5\text{ MHz}$							
Second harmonic distortion	$R_L = 150\ \Omega$	-78					dBc	Typ
Third harmonic distortion	$R_L = 150\ \Omega$	-85					dBc	Typ
Differential gain (NTSC, PAL)	$G = 2$, $R = 150\ \Omega$	0.007					%	Typ
Differential phase (NTSC, PAL)	$G = 2$, $R = 150\ \Omega$	0.007					°	Typ
Input voltage noise	$f = 1\text{ MHz}$	13					nV/ $\sqrt{\text{Hz}}$	Typ
Input current noise	$f = 1\text{ MHz}$	0.8					pA/ $\sqrt{\text{Hz}}$	Typ
Crosstalk (dual and triple only)	$f = 5\text{ MHz}$ Ch-to-Ch	-90					dB	Typ

(1) Full-power bandwidth = $SR / 2\pi V_{pp}$

DC PERFORMANCE								
Open-loop voltage gain (A_{OL})	$V_O = \pm 2\text{ V}$	100	80	75	75		dB	Min
Input offset voltage	$V_{CM} = 0\text{ V}$	12	25	30	30		mV	Max
Input bias current	$V_{CM} = 0\text{ V}$	0.9	3	5	5		μA	Max
Input offset current	$V_{CM} = 0\text{ V}$	100	500	700	700		nA	Max

INPUT CHARACTERISTICS								
Common-mode input range		-4 / 4	-3.9 / 3.9				V	Min
Common-mode rejection ratio	$V_{CM} = \pm 2\text{ V}$	94	70	65	65		dB	Min
Input resistance		33					M Ω	Typ
Input capacitance	Common-mode / differential	1 / 0.5					pF	Max

OUTPUT CHARACTERISTICS								
Output voltage swing	$R_L = 150\ \Omega$	-4.5 / 4.5					V	Typ
	$R_L = 499\ \Omega$	-4.7 / 4.7	-4.5 / 4.5	-4.4 / 4.4	-4.4 / 4.4		V	Min
Output current (sourcing)	$R_L = 10\ \Omega$	100	92	88	88		mA	Min
Output current (sinking)	$R_L = 10\ \Omega$	-100	-92	-88	-88		mA	Min
Output impedance	$f = 1\text{ MHz}$	0.09					Ω	Typ

POWER SUPPLY								
Specified operating voltage		± 5	± 9	± 9	± 9		V	Max
Maximum quiescent current	Per channel	14	18	20	22		mA	Max
Power supply rejection ($\pm\text{PSRR}$)		75	62	60	60		dB	Min

ELECTRICAL CHARACTERISTICS

$V_S = 5\text{ V}$, $R_L = 150\ \Omega$, and $G = 2$ unless otherwise noted

PARAMETER	TEST CONDITIONS	TYP	OVER TEMPERATURE				UNITS	MIN/ MAX
		25°C	25°C	0°C to 70°C	-40°C to 85°C			
AC PERFORMANCE								
Small signal bandwidth	$G = 1$, $V_O = 100\text{ mV}_{pp}$	170					MHz	Typ
	$G = 2$, $V_O = 100\text{ mV}_{pp}$, $R_f = 1.5\text{ k}\Omega$	100					MHz	Typ
	$G = 10$, $V_O = 100\text{ mV}_{pp}$, $R_f = 1.5\text{ k}\Omega$	12					MHz	Typ
0.1 dB flat bandwidth	$G = 2$, $V_O = 100\text{ mV}_{pp}$, $R_f = 1.24\text{ k}\Omega$	50					MHz	Typ
Gain bandwidth product	$G > 10$, $f = 1\text{ MHz}$, $R_f = 1.5\text{ k}\Omega$	120					MHz	Typ
Full-power bandwidth ⁽¹⁾	$G = 2$, $V_O = 4\text{ V step}$	60					MHz	Typ
Slew rate	$G = 2$, $V_O = 4\text{ V step}$	750					V/ μs	Min
Settling time to 0.1%	$G = -2$, $V_O = 2\text{ V step}$	27					ns	Typ
Settling time to 0.01%	$G = -2$, $V_O = 2\text{ V}_{pp}$	48					ns	Typ
Harmonic distortion	$G = 2$, $V_O = 2\text{ V}_{pp}$, $f = 5\text{ MHz}$							
Second harmonic distortion	$R_L = 150\ \Omega$	-82					dBc	Typ
Third harmonic distortion	$R_L = 150\ \Omega$	-88					dBc	Typ
Differential gain (NTSC, PAL)	$G = 2$, $R = 150\ \Omega$	0.014					%	Typ
Differential phase (NTSC, PAL)	$G = 2$, $R = 150\ \Omega$	0.011					°	Typ
Input voltage noise	$f = 1\text{ MHz}$	13					nV/ $\sqrt{\text{Hz}}$	Typ
Input current noise	$f = 1\text{ MHz}$	0.8					pA/ $\sqrt{\text{Hz}}$	Typ
Crosstalk (dual and triple only)	$f = 5\text{ MHz Ch-to-Ch}$	-90					dB	Typ

(1) Full-power bandwidth = $SR / 2\pi V_{pp}$

DC PERFORMANCE								
Open-loop voltage gain (A_{OL})	$V_O = 1.5\text{ V to }3.5\text{ V}$	100	80	75	75		dB	Min
Input offset voltage	$V_{CM} = 2.5\text{ V}$	12	25	30	30		mV	Max
Input bias current	$V_{CM} = 2.5\text{ V}$	0.9	3	5	5		μA	Max
Input offset current	$V_{CM} = 2.5\text{ V}$	100	500	700	700		nA	Max

INPUT CHARACTERISTICS								
Common-mode input range		1 / 4	1.1 / 3.9				V	Min
Common-mode rejection ratio	$V_{CM} = 1.5\text{ V to }3.5\text{ V}$	96	70	65	65		dB	Min
Input resistance		33					M Ω	Typ
Input capacitance	Common-mode / differential	1 / 0.5					pF	Max

OUTPUT CHARACTERISTICS								
Output voltage swing	$R_L = 150\ \Omega$	0.5 / 4.5					V	Typ
	$R_L = 499\ \Omega$	0.2 / 4.8	0.3 / 4.7	0.4 / 4.6	0.4 / 4.6		V	Min
Output current (sourcing)	$R_L = 10\ \Omega$	95	85	80	80		mA	Min
Output current (sinking)	$R_L = 10\ \Omega$	-95	-85	-80	-80		mA	Min
Output impedance	$f = 1\text{ MHz}$	0.09					Ω	Typ

POWER SUPPLY								
Specified operating voltage		5	18	18	18		V	Max
Maximum quiescent current	Per channel	12	15	17	19		mA	Max
Power supply rejection ($\pm\text{PSRR}$)		70	62	60	60		dB	Min

PIN ASSIGNMENTS

PACKAGE DEVICES

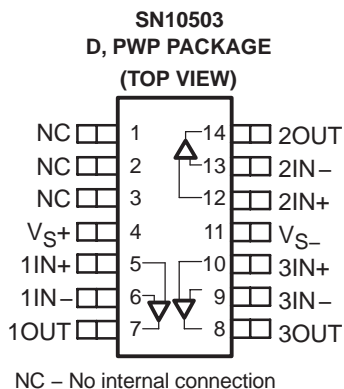
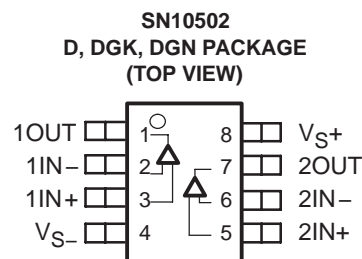
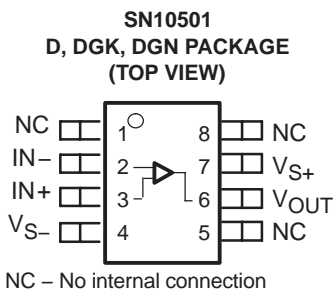
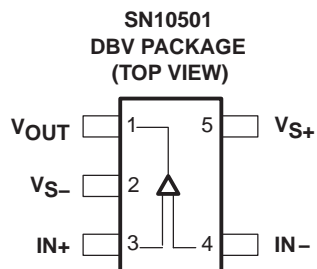

TYPICAL CHARACTERISTICS

TABLE OF GRAPHS

	FIGURE
Frequency response	1 – 8
Small signal frequency response	9, 10
Large signal frequency response	11
Slew rate vs Output voltage step	12, 13
Harmonic distortion vs Frequency	14, 15
Voltage and current noise vs Frequency	16
Differential gain vs Number of loads	17, 18
Differential phase vs Number of loads	19, 20
Quiescent current vs Supply voltage	21
Output voltage vs Load resistance	22
Open-loop gain and phase vs Frequency	23
Rejection ratio vs Frequency	24
Rejection ratio vs Case temperature	25
Common-mode rejection ratio vs Input common-mode range	26, 27
Output impedance vs Frequency	28, 29
Crosstalk vs Frequency	30
Input bias and offset current vs Case temperature	31, 32

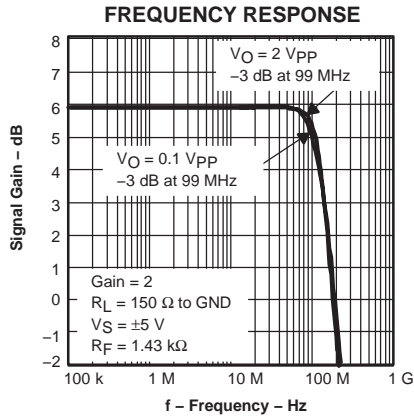

Figure 1

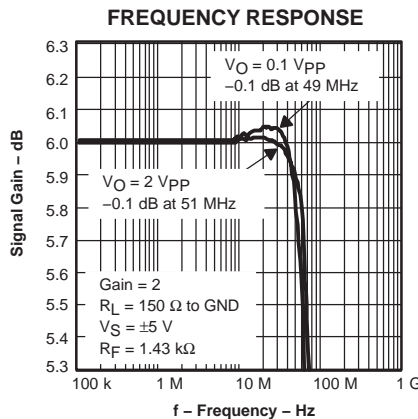

Figure 2

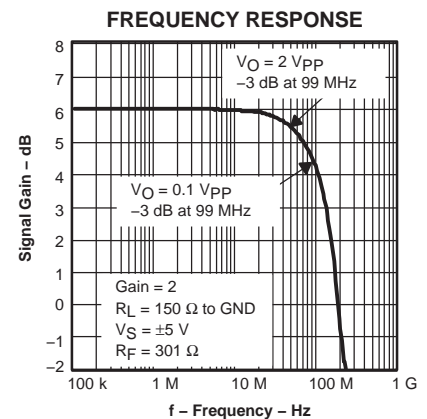

Figure 3

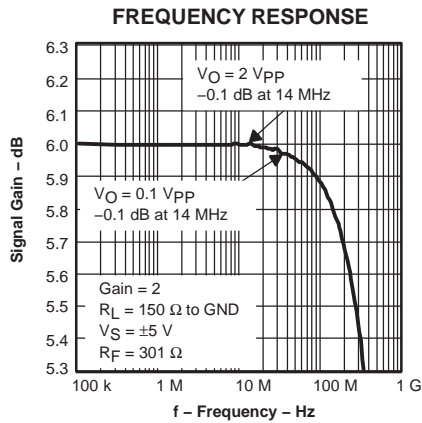

Figure 4

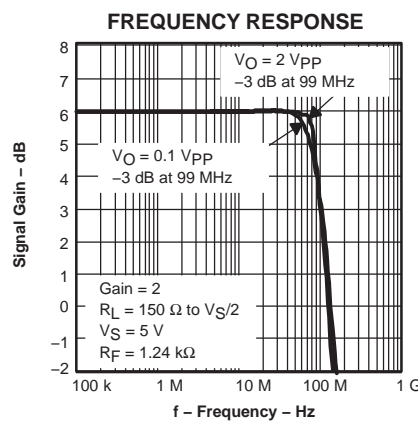

Figure 5

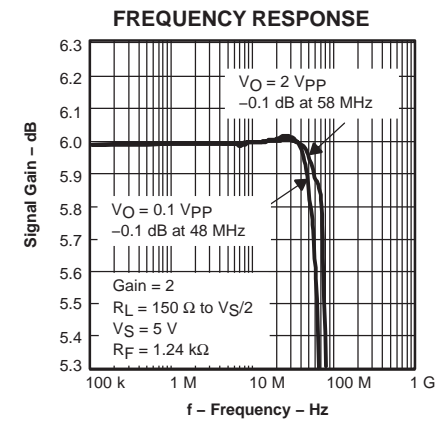

Figure 6

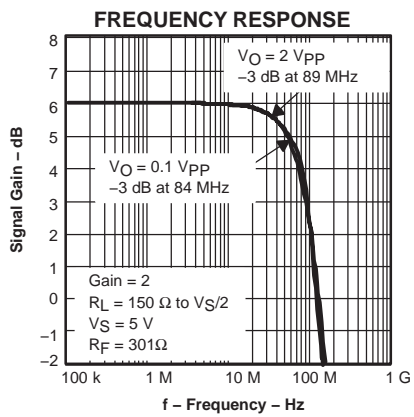

Figure 7

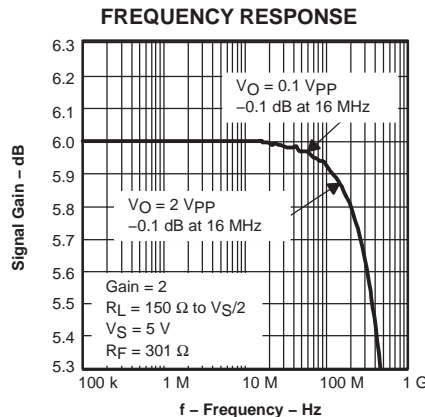

Figure 8

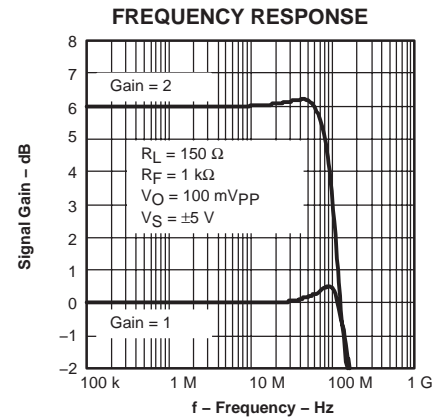

Figure 9

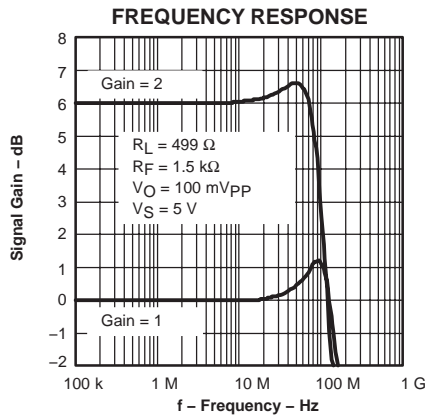

Figure 10

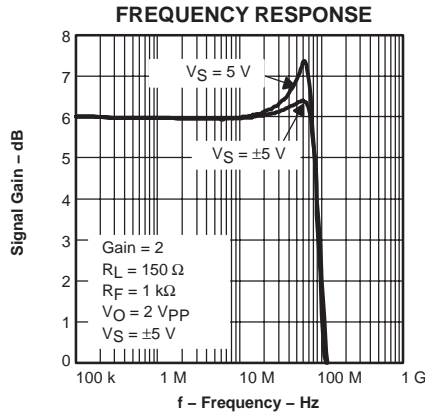

Figure 11

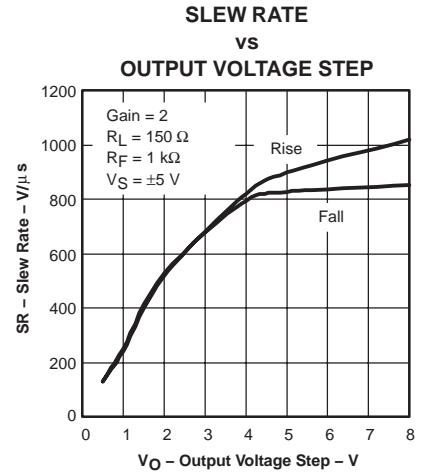

Figure 12

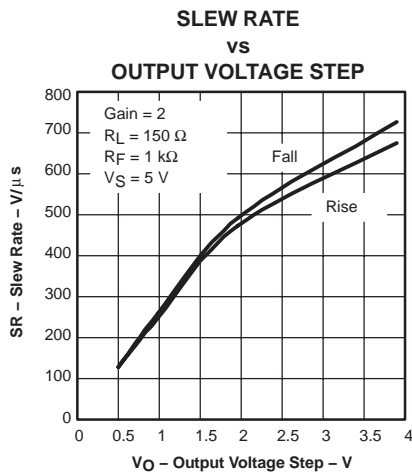

Figure 13

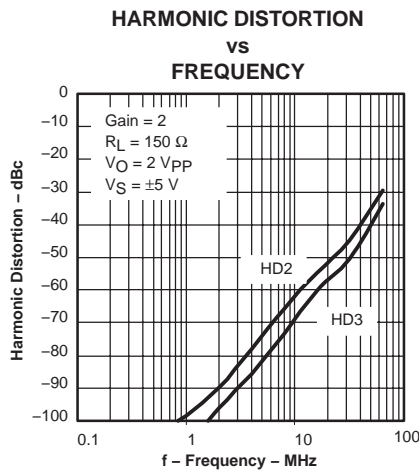

Figure 14

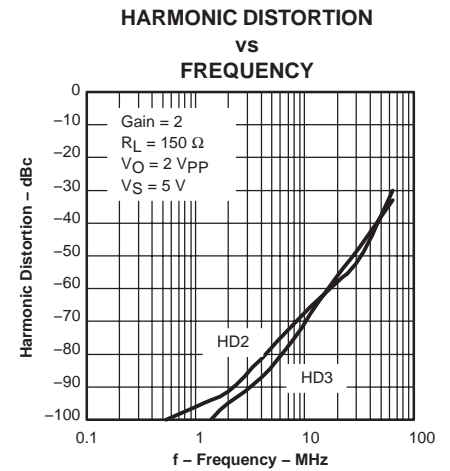

Figure 15

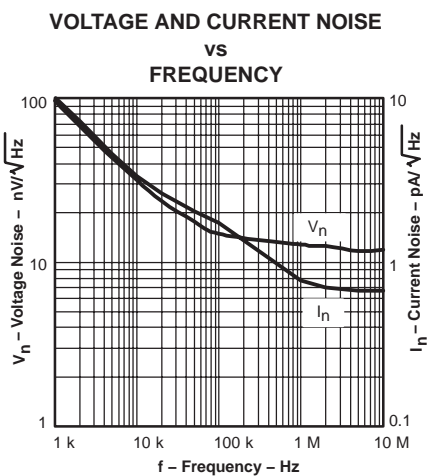

Figure 16

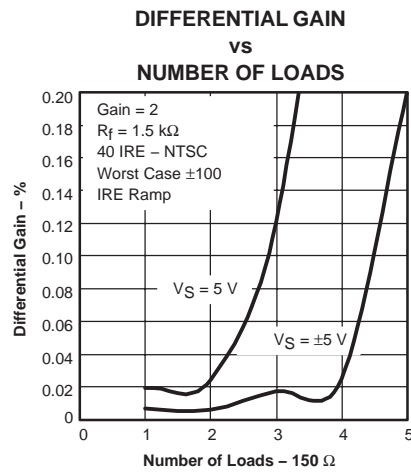

Figure 17

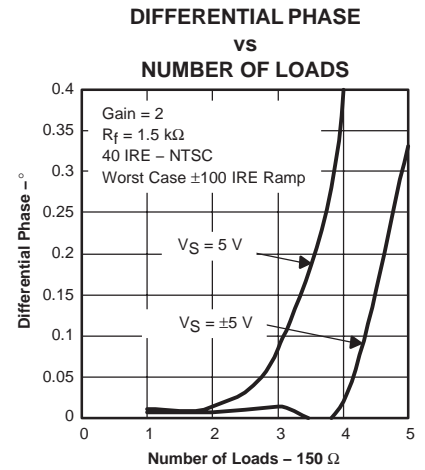

Figure 18

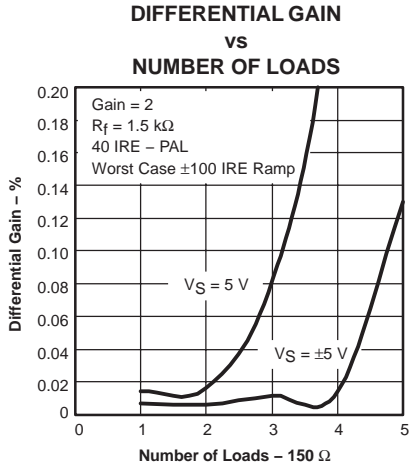

Figure 19

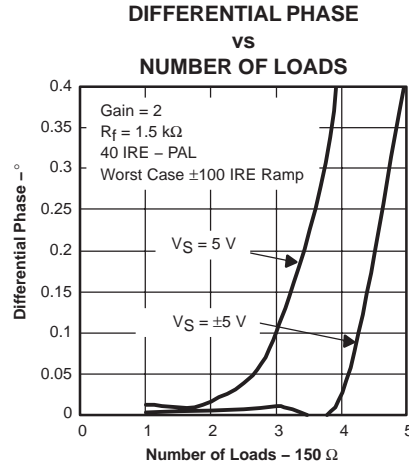

Figure 20

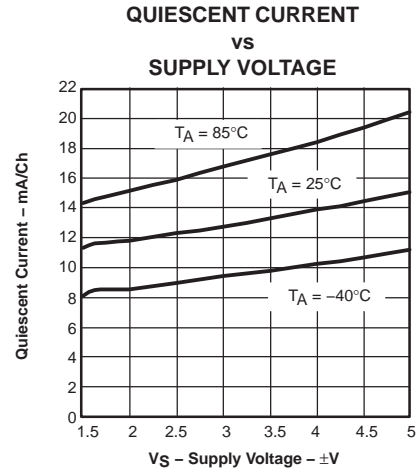

Figure 21

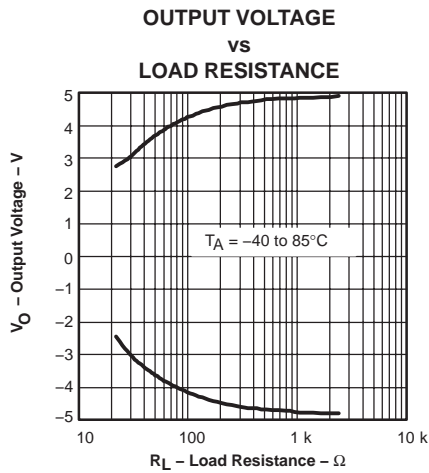

Figure 22

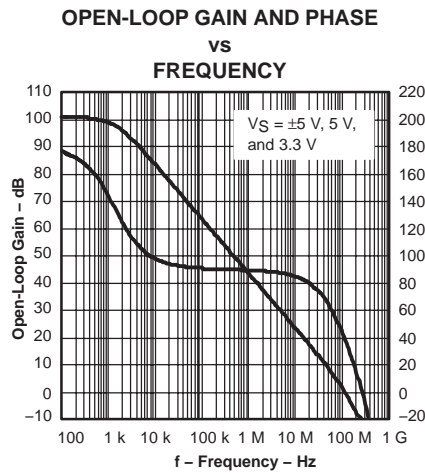

Figure 23

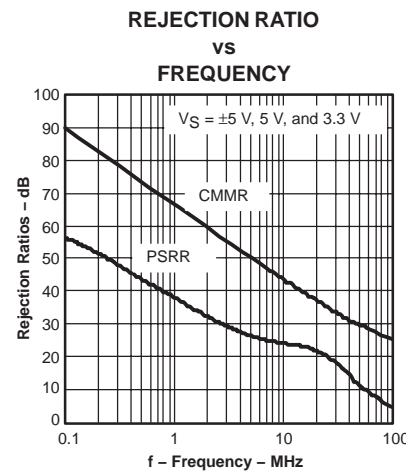

Figure 24

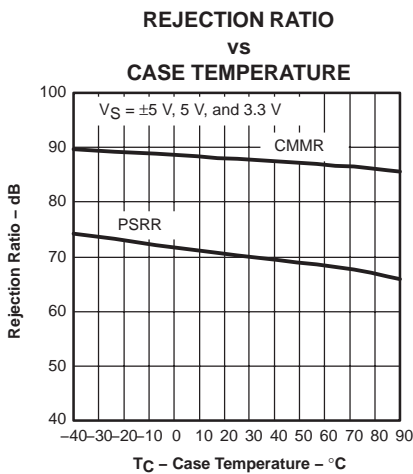

Figure 25

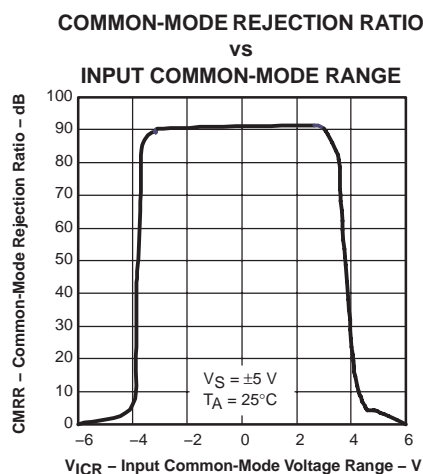

Figure 26

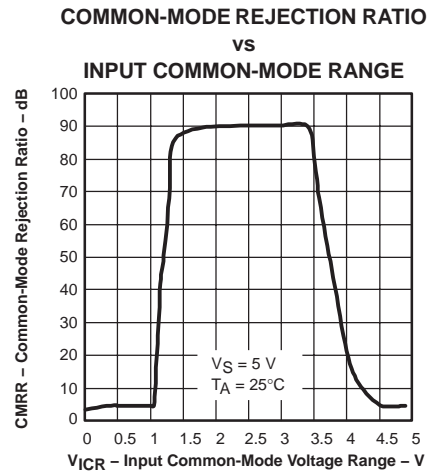

Figure 27

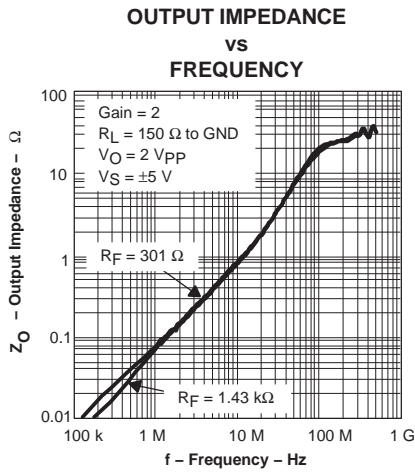

Figure 28

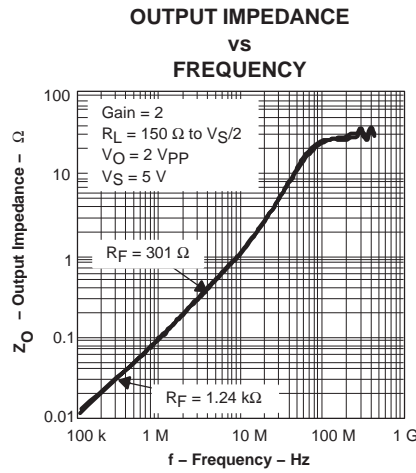

Figure 29

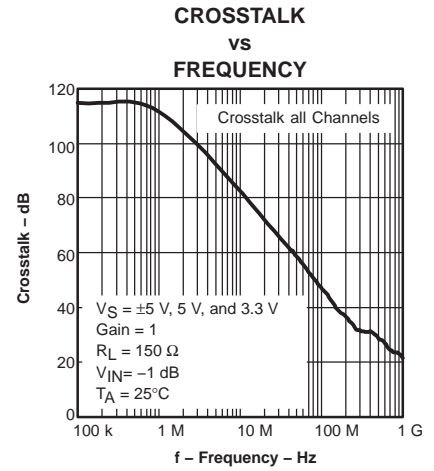

Figure 30

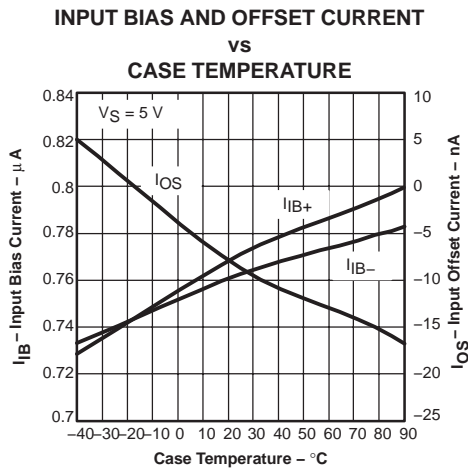

Figure 31

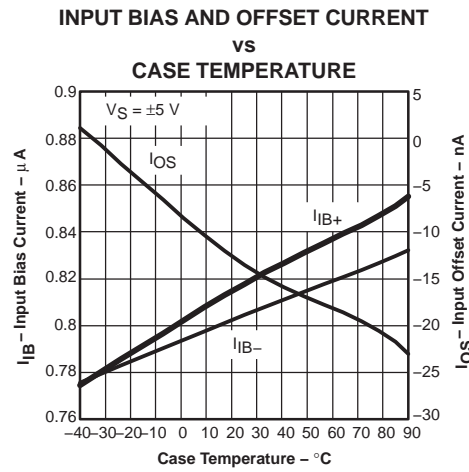

Figure 32

APPLICATION INFORMATION

HIGH-SPEED OPERATIONAL AMPLIFIERS

The SN1050x operational amplifiers are a family of single, dual, and triple rail-to-rail output voltage feedback amplifiers. The SN1050x family combines both a high slew rate and a rail-to-rail output stage.

Applications Section Contents

- Wideband, Noninverting Operation
- Wideband, Inverting Gain Operation
- Video Drive Circuits
- Single Supply Operation
- Power Supply Decoupling Techniques and Recommendations
- Active Filtering With the SN1050x
- Driving Capacitive Loads
- Board Layout
- Thermal Analysis
- Additional Reference Material
- Mechanical Package Drawings

WIDEBAND, NONINVERTING OPERATION

The SN1050x is a family of unity gain stable rail-to-rail output voltage feedback operational amplifiers designed to operate from a single 3-V to 15-V power supply.

Figure 33 is the noninverting gain configuration of 2 V/V used to demonstrate the typical performance curves.

Voltage feedback amplifiers, unlike current feedback designs, can use a wide range of resistor values to set their gain with minimal impact on their stability and frequency response. Larger-valued resistors decrease the loading effect of the feedback network on the output of the amplifier, but this enhancement comes at the expense of additional noise and potentially lower bandwidth. Feedback resistor values between 1 k Ω and 2 k Ω are recommended for most situations.

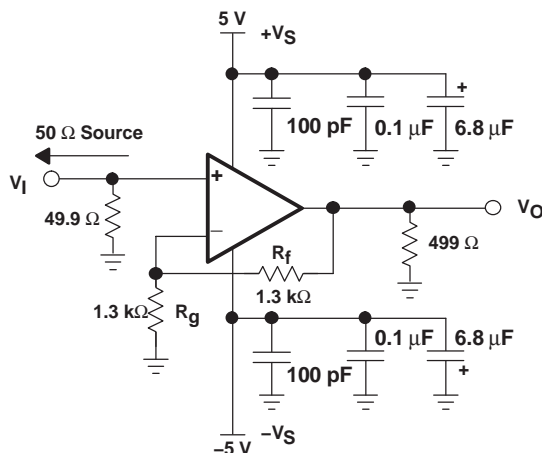

Figure 33. Wideband, Noninverting Gain Configuration

WIDEBAND, INVERTING OPERATION

Since the SN1050x family are general-purpose, wideband voltage-feedback amplifiers, several familiar operational amplifier applications circuits are available to the designer. Figure 34 shows a typical inverting configuration where the input and output impedances and noise gain from Figure 33 are retained in an inverting circuit configuration. Inverting operation is one of the more common requirements and offers several performance benefits. The inverting configuration shows improved slew rates and distortion due to the pseudo-static voltage maintained on the inverting input.

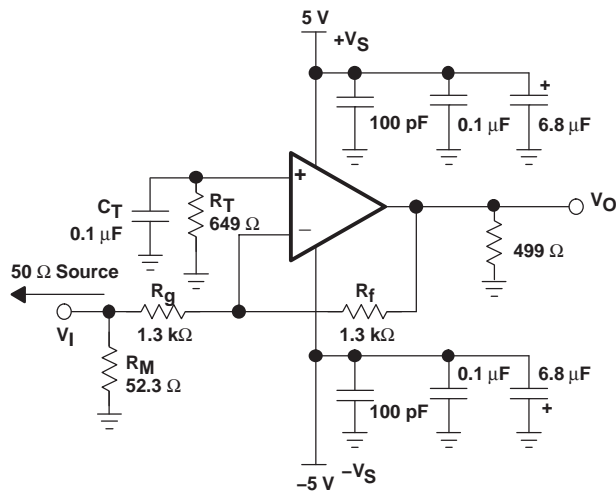

Figure 34. Wideband, Inverting Gain Configuration

In the inverting configuration, some key design considerations must be noted. One is that the gain resistor (R_g) becomes part of the signal channel input impedance. If the input impedance matching is desired (which is beneficial whenever the signal is coupled through a cable, twisted pair, long PC board trace, or other transmission line conductors), R_g may be set equal to the required termination value and R_f adjusted to give the desired gain. However, care must be taken when dealing with low inverting gains, as the resultant feedback resistor value can present a significant load to the amplifier output. For an inverting gain of 2, setting R_g to 49.9 Ω for input matching eliminates the need for R_M but requires a 100- Ω feedback resistor. This has an advantage of the noise gain becoming equal to 2 for a 50- Ω source impedance—the same as the noninverting circuit in Figure 33. However, the amplifier output now sees the 100- Ω feedback resistor in parallel with the external load. To eliminate this excessive loading, it is preferable to increase both R_g and R_f values, as shown in Figure 34, and then achieve the input matching impedance with a third resistor (R_M) to ground. The total input impedance becomes the parallel combination of R_g and R_M .

The last major consideration to discuss in inverting amplifier design is setting the bias current cancellation resistor on the noninverting input. If the resistance is set equal to the total dc resistance looking out of the inverting terminal, the output dc error, due to the input bias currents, is reduced to (input offset current) multiplied by R_f in Figure 34, the dc source impedance looking out of the inverting terminal is $1.3 \text{ k}\Omega \parallel (1.3 \text{ k}\Omega + 25.6 \text{ }\Omega) = 649 \text{ }\Omega$. To reduce the additional high-frequency noise introduced by the resistor at the noninverting input, and power-supply feedback, R_T is bypassed with a capacitor to ground.

SINGLE SUPPLY OPERATION

The SN1050x family is designed to operate from a single 3-V to 15-V power supply. When operating from a single power supply, care must be taken to ensure the input signal and amplifier are biased appropriately to allow for the maximum output voltage swing. The circuits shown in Figure 35 demonstrate methods to configure an amplifier in a manner conducive for single supply operation.

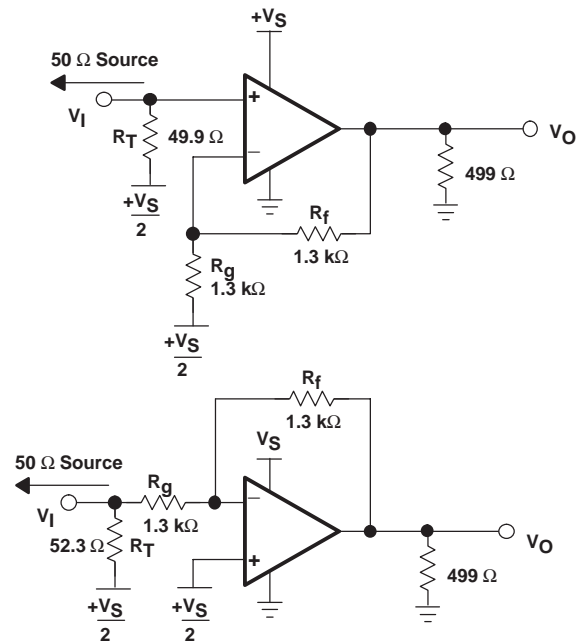

Figure 35. DC-Coupled Single Supply Operation

VIDEO DRIVE CIRCUITS

Most video distribution systems are designed with 75- Ω series resistors to drive a matched 75- Ω cable. In order to deliver a net gain of 1 to the 75- Ω matched load, the amplifier is typically set up for a voltage gain of +2, compensating for the 6-dB attenuation of the voltage divider formed by the series and shunt 75- Ω resistors at either end of the cable. The circuit shown in Figure 36 applies to this requirement. Both the gain flatness and the differential gain / phase performance of the SN1050x provides exceptional results in video distribution applications.

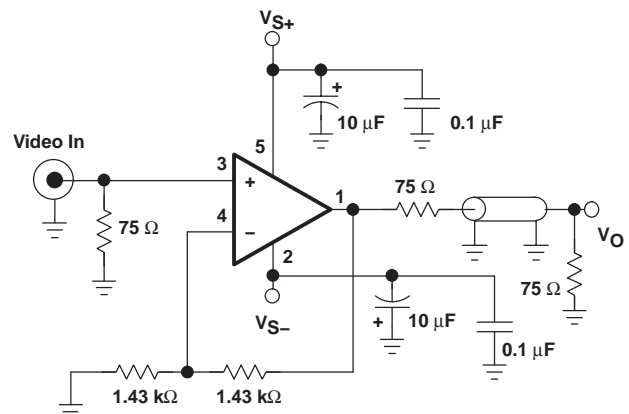

Figure 36. Cable Drive Application

Differential gain and phase measure the change in overall small-signal gain and phase for the color subcarrier frequency (3.58 MHz in NTSC systems) vs changes in the large-signal output level (which represents luminance information in a composite video signal). The SN1050x, with the typical 150- Ω load of a single matched video cable, shows less than 0.007% / 0.007° differential gain/phase errors over the standard luminance range for a positive video (negative sync) signal. Similar performance is observed for negative video signals. In practice, similar performance is achieved even with three video loads as shown in Figure 37 due to the linear high-frequency output impedance of the SN1050x.

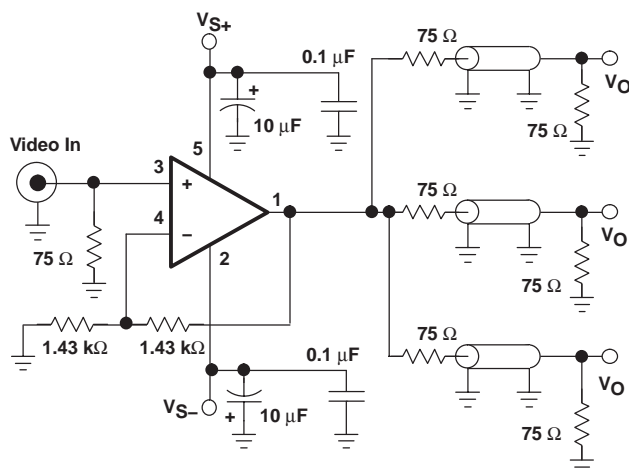

Figure 37. Video Distribution

The above circuit is suitable for driving video cables, provided that the length does not exceed a few feet. If longer cables are driven, the gain of the SN1050x can be increased to accommodate cable drops.

Configuring the SN1050x for single supply video applications is easily done. But, attention must be made to the bias voltages at the input and output to ensure the system works as desired. Unlike some video amplifiers, the input common-mode voltage range of the SN1050x amplifiers do not include the negative power supply, but rather it is about 1-V from each power supply. For split supply configurations, this is very beneficial. But for single-supply systems, there are some design constraints that must be adhered to.

Figure 38 shows a single supply video configuration illustrating the dc bias voltages acceptable for the SN1050x. The lower end of the input common-mode range is specified as 1 V. While the upper end is limited to 4 V with the 5-V supply shown, the output range and gain of 2 limits the highest acceptable input voltage to $4.5 \text{ V} / 2 = 2.25 \text{ V}$. The 4.5-V output is what is typically expected with a 150- Ω load. It is easily seen that the input voltage range and/or

the output voltage range will be the limiting factor in the total system and both specifications must be taken into account when designing a system.

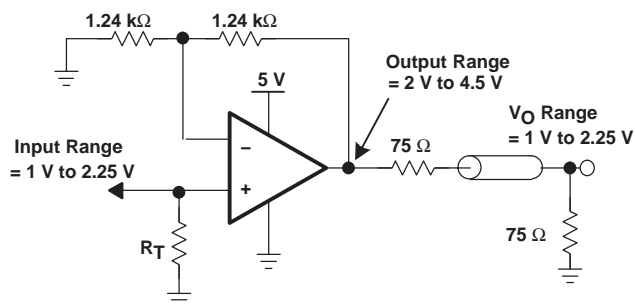

Figure 38. DC-Coupled Single-Supply Video Amplifier

In most systems, this may be acceptable because most receivers are ac-coupled and set the blank level to the desired system value, typically 0 V (0-IRE). But, to ensure full compatibility with any system, it is often desirable to place an ac-coupling capacitor on the output as shown in Figure 39. This eliminates the dc-bias voltage appearing at the amplifier output. To minimize field tilt, the size of this capacitor is typically 470 μF , although values as small as 220 μF have been utilized with acceptable results.

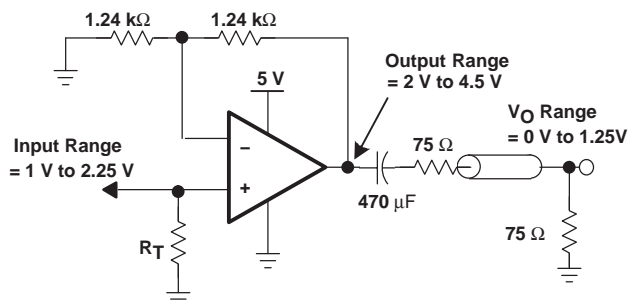

Figure 39. AC-Coupled Output Single-Supply Video Amplifier

In some systems, the physical size and sometimes cost of a 470- μF capacitor can be prohibitive. One way to circumvent this issue is to utilize two smaller capacitors in a feedback configuration as shown in Figure 40. This is commonly known as SAG correction. This circuit increases the gain of the amplifier up to 3 V/V at low frequencies to counteract the increased impedance of the capacitor placed at the amplifier output. One issue that must be resolved is the gain at low frequencies is typically limited by the power-supply voltage and the output swing of the amplifier. Therefore, it is possible to saturate the amplifier at these low frequencies if full analysis is not done on this system which includes both input and output requirements.

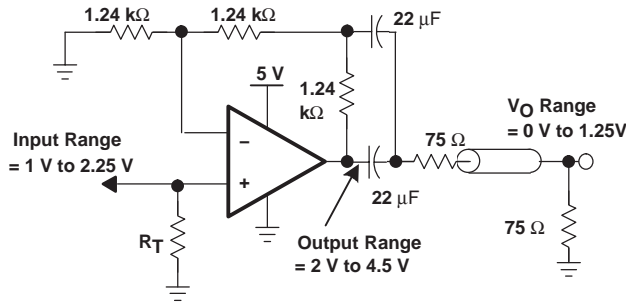

Figure 40. AC-Coupled SAG Corrected Output Single-Supply Video Amplifier

Many times the output of the video encoder or DAC does not have the capability to output the 1-V to 2.25-V range, but rather a 0-V to 1.25-V range. In this instance, the signal must be ac-coupled to the amplifier input as shown in Figure 41. Note that it does not matter what the voltage output of the DAC is, but rather the voltage swing should be kept less than $1.25 V_{PP}$.

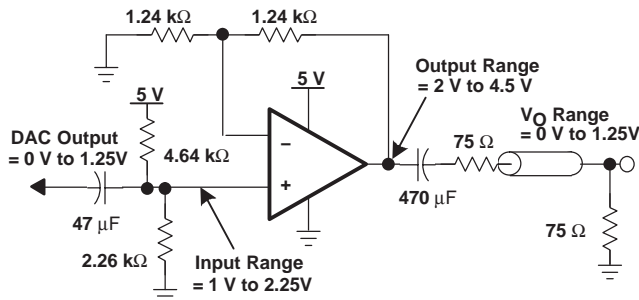

Figure 41. AC-Coupled Input and Output Single-Supply Video Amplifier

To have even more dynamic range at the output, the dc-bias at the output should be centered around 2.5 V for the 5-V system shown. But, to have a wide output range the input must also have a wide range and should be centered around 2.5 V. The best ways to accomplish this is to either ac-couple the gain resistor or bias it at 2.5 V utilizing a reference supply as shown in Figure 42 and Figure 43.

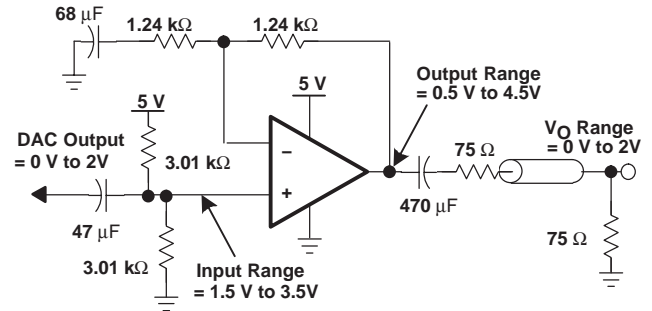

Figure 42. AC-Coupled Wide Output Swing Single-Supply Video Amplifier

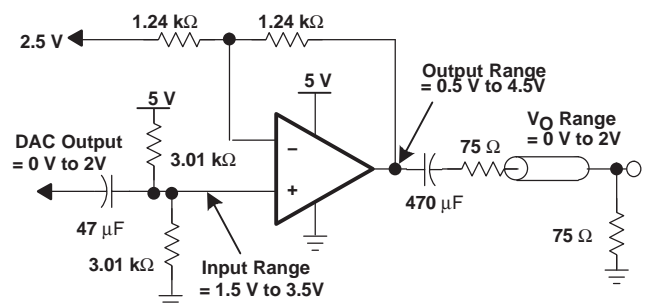

Figure 43. AC-Coupled Wide Output Swing Single-Supply Video Amplifier Utilizing Voltage Reference

Another configuration that can be beneficial is to utilize the amplifier in an inverting configuration is shown in Figure 44.

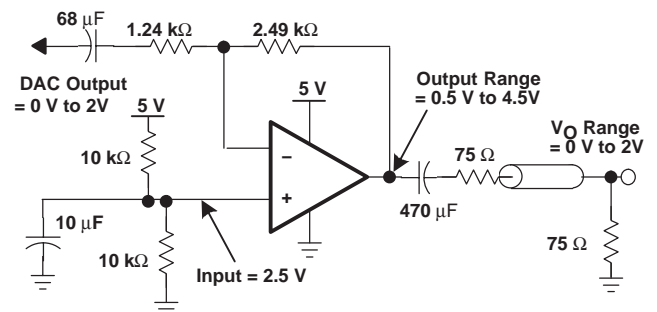

Figure 44. Inverting AC-Coupled Wide Output Swing Single-Supply Video Amplifier

APPLICATION CIRCUITS

Active Filtering With the SN1050x

High-frequency active filtering with the SN1050x is achievable due to the amplifier's high slew rate, wide bandwidth, and voltage feedback architecture. Several options are available for high-pass, low-pass, bandpass, and bandstop filters of varying orders. A simple two-pole low pass filter is presented here as an example, with two poles at 25 MHz.

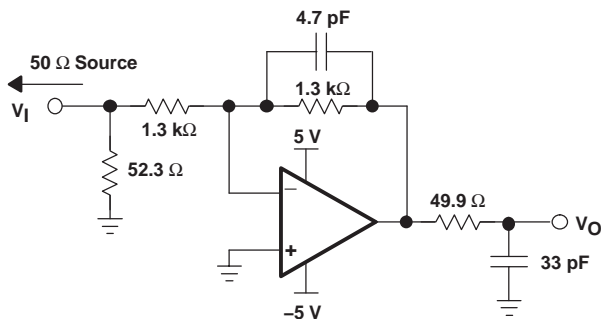

Figure 45. A Two-Pole Active Filter With Two Poles Between 90 MHz and 100 MHz

Driving Capacitive Loads

One of the most demanding, and yet very common, load conditions for an op amp is capacitive loading. Often, the capacitive load is the input of an A/D converter, including additional external capacitance, which may be recommended to improve A/D linearity. A high-speed, high open-loop gain amplifier like the SN1050x can be very susceptible to decreased stability and closed-loop response peaking when a capacitive load is placed directly on the output pin. When the amplifier's open-loop output resistance is considered, this capacitive load introduces an additional pole in the signal path that can decrease the phase margin. When the primary considerations are frequency response flatness, pulse response fidelity, or distortion, the simplest and most effective solution is to isolate the capacitive load from the feedback loop by inserting a series isolation resistor between the amplifier output and the capacitive load. This does not eliminate the pole from the loop response, but rather shifts it and adds a zero at a higher frequency. The additional zero acts to cancel the phase lag from the capacitive load pole, thus increasing the phase margin and improving stability.

Power Supply Decoupling Techniques and Recommendations

Power supply decoupling is a critical aspect of any high-performance amplifier design process. Careful decoupling provides higher quality ac performance (most notably improved distortion performance). The following guidelines ensure the highest level of performance.

1. Place decoupling capacitors as close to the power supply inputs as possible, with the goal of minimizing the inductance of the path from ground to the power supply.
2. Placement priority should put the smallest valued capacitors closest to the device.
3. Use of solid power and ground planes is recommended to reduce the inductance along power supply return current paths, with the exception of the areas underneath the input and output pins.
4. Recommended values for power supply decoupling include a bulk decoupling capacitor (6.8 to 22 μ F), a mid-range decoupling capacitor (0.1 μ F) and a high frequency decoupling capacitor (1000 pF) for each supply. A 100 pF capacitor can be used across the supplies as well for extremely high frequency return currents, but often is not required.

BOARD LAYOUT

Achieving optimum performance with a high frequency amplifier like the SN1050x requires careful attention to board layout parasitics and external component types.

Recommendations that will optimize performance include:

1. **Minimize parasitic capacitance to any ac ground for all of the signal I/O pins.** Parasitic capacitance on the output and inverting input pins can cause instability: on the noninverting input, it can react with the source impedance to cause unintentional band limiting. To reduce unwanted capacitance, a window around the signal I/O pins should be opened in all of the ground and power planes around those pins. Otherwise, ground and power planes should be unbroken elsewhere on the board.
2. **Minimize the distance (< 0.25") from the power supply pins to high frequency 0.1- μ F decoupling capacitors.** At the device pins, the ground and power plane layout should not be in close proximity to the signal I/O pins. Avoid narrow power and ground traces to minimize inductance between the pins and the decoupling capacitors. The power supply connections should always be decoupled with these capacitors. Larger (2.2- μ F to 6.8- μ F) decoupling capacitors, effective at lower frequency, should also be used on the main supply pins. These may be placed somewhat farther from the device and may be shared among several devices in the same area of the PC board.
3. **Careful selection and placement of external components preserves the high frequency performance of the SN1050x.** Resistors should be a very low reactance type. Surface-mount resistors work best and allow a tighter overall layout. Metal-film and carbon composition, axially-leaded resistors can also provide good high frequency performance. Again, keep their leads and PC board trace length as short as possible. Never use wire wound type resistors in a high frequency application. Since the output pin and inverting input pin are the most sensitive to parasitic capacitance, always position the feedback and series output resistor, if any, as close as possible to the output pin. Other network components, such as noninverting input termination resistors, should also be placed close to the package. Where double-side component mounting is allowed, place the feedback resistor directly under the package on the other side of the board between the output and inverting input pins. Even with a low parasitic capacitance shunting the external resistors, excessively high resistor values can create significant time constants that can degrade performance. Good axial metal-film or surface-mount resistors have approximately 0.2 pF in shunt with the resistor. For resistor values > 2.0 k Ω , this parasitic capacitance can

add a pole and/or a zero below 400 MHz that can effect circuit operation. Keep resistor values as low as possible, consistent with load driving considerations. It has been suggested that a good starting point for design is to set the R_f to 1.3 k Ω for low-gain, noninverting applications. Doing this automatically keeps the resistor noise terms low, and minimizes the effect of their parasitic capacitance.

4. **Connections to other wideband devices on the board may be made with short direct traces or through onboard transmission lines.** For short connections, consider the trace and the input to the next device as a lumped capacitive load. Relatively wide traces (50 mils to 100 mils) should be used, preferably with ground and power planes opened up around them. Estimate the total capacitive load and set R_{ISO} from the plot of recommended R_{ISO} vs Capacitive Load. Low parasitic capacitive loads (<4 pF) may not need an R_{ISO} , since the SN1050x is nominally compensated to operate with a 2-pF parasitic load. Higher parasitic capacitive loads without an R_{ISO} are allowed as the signal gain increases (increasing the unloaded phase margin). If a long trace is required, and the 6-dB signal loss intrinsic to a doubly-terminated transmission line is acceptable, implement a matched impedance transmission line using microstrip or stripline techniques (consult an ECL design handbook for microstrip and stripline layout techniques). A 50- Ω environment is normally not necessary onboard, and in fact a higher impedance environment improves distortion as shown in the distortion versus load plots. With a characteristic board trace impedance defined based on board material and trace dimensions, a matching series resistor into the trace from the output of the SN1050x is used as well as a terminating shunt resistor at the input of the destination device. Remember also that the terminating impedance is the parallel combination of the shunt resistor and the input impedance of the destination device: this total effective impedance should be set to match the trace impedance. If the 6-dB attenuation of a doubly terminated transmission line is unacceptable, a long trace can be series-terminated at the source end only. Treat the trace as a capacitive load in this case and set the series resistor value as shown in the plot of R_{ISO} vs Capacitive Load. This setting does not preserve signal integrity or a doubly-terminated line. If the input impedance of the destination device is low, there is some signal attenuation due to the voltage divider formed by the series output into the terminating impedance.

5. **Socketing a high speed part like the SN1050x is not recommended.** The additional lead length and pin-to-pin capacitance introduced by the socket can create a troublesome parasitic network which can make it almost impossible to achieve a smooth, stable frequency response. Best results are obtained by soldering the SN1050x onto the board.

THERMAL ANALYSIS

The SN1050x family of devices does not incorporate automatic thermal shutoff protection, so the designer must take care to ensure that the design does not violate the absolute maximum junction temperature of the device. Failure may result if the absolute maximum junction temperature of 150° C is exceeded.

The thermal characteristics of the device are dictated by the package and the PC board. Maximum power dissipation for a given package can be calculated using the following formula.

$$P_{Dmax} = \frac{T_{max} - T_A}{\theta_{JA}}$$

where:

P_{Dmax} is the maximum power dissipation in the amplifier (W).

T_{max} is the absolute maximum junction temperature (°C).

T_A is the ambient temperature (°C).

$\theta_{JA} = \theta_{JC} + \theta_{CA}$

θ_{JC} is the thermal coefficient from the silicon junctions to the case (°C/W).

θ_{CA} is the thermal coefficient from the case to ambient air (°C/W).

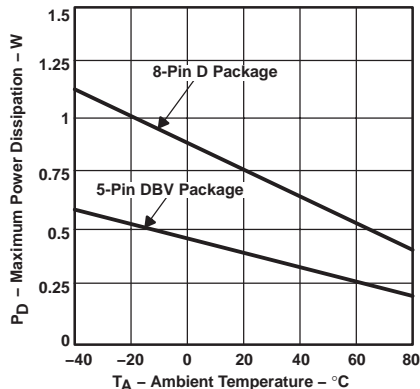

$\theta_{JA} = 170^{\circ}\text{C/W}$ for 8-Pin SOIC (D)
 $\theta_{JA} = 324.1^{\circ}\text{C/W}$ for 5-Pin SOT-23 (DBV)
 $T_J = 150^{\circ}\text{C}$, No Airflow

Figure 46. Maximum Power Dissipation vs Ambient Temperature

When determining whether or not the device satisfies the maximum power dissipation requirement, it is important to consider not only quiescent power dissipation, but also dynamic power dissipation. Often maximum power dissipation is difficult to quantify because the signal pattern is inconsistent, but an estimate of the RMS power dissipation can provide visibility into a possible problem.

PACKAGING INFORMATION

Orderable Device	Status ⁽¹⁾	Package Type	Package Drawing	Pins	Package Qty	Eco Plan ⁽²⁾	Lead/Ball Finish	MSL Peak Temp ⁽³⁾
SN10501D	ACTIVE	SOIC	D	8	75	Pb-Free (RoHS)	CU NIPDAU	Level-2-260C-1YEAR/ Level-1-220C-UNLIM
SN10501DBVR	ACTIVE	SOT-23	DBV	5	3000	Green (RoHS & no Sb/Br)	CU NIPDAU	Level-1-260C-UNLIM
SN10501DBVT	ACTIVE	SOT-23	DBV	5	250	Green (RoHS & no Sb/Br)	CU NIPDAU	Level-1-260C-UNLIM
SN10501DGK	ACTIVE	MSOP	DGK	8	100	Green (RoHS & no Sb/Br)	CU NIPDAU	Level-1-260C-UNLIM
SN10501DGKR	ACTIVE	MSOP	DGK	8	2500	Green (RoHS & no Sb/Br)	CU NIPDAU	Level-1-260C-UNLIM
SN10501DGN	ACTIVE	MSOP-Power PAD	DGN	8	80	Green (RoHS & no Sb/Br)	CU NIPDAU	Level-1-260C-UNLIM
SN10501DGNR	ACTIVE	MSOP-Power PAD	DGN	8	2500	Green (RoHS & no Sb/Br)	CU NIPDAU	Level-1-260C-UNLIM
SN10501DR	ACTIVE	SOIC	D	8	2500	Pb-Free (RoHS)	CU NIPDAU	Level-2-260C-1YEAR/ Level-1-220C-UNLIM
SN10502D	ACTIVE	SOIC	D	8	75	Pb-Free (RoHS)	CU NIPDAU	Level-2-260C-1YEAR/ Level-1-220C-UNLIM
SN10502DGK	ACTIVE	MSOP	DGK	8	100	Green (RoHS & no Sb/Br)	CU NIPDAU	Level-1-260C-UNLIM
SN10502DGKR	ACTIVE	MSOP	DGK	8	2500	Green (RoHS & no Sb/Br)	CU NIPDAU	Level-1-260C-UNLIM
SN10502DGN	ACTIVE	MSOP-Power PAD	DGN	8	80	Green (RoHS & no Sb/Br)	CU NIPDAU	Level-1-260C-UNLIM
SN10502DGNR	ACTIVE	MSOP-Power PAD	DGN	8	2500	Green (RoHS & no Sb/Br)	CU NIPDAU	Level-1-260C-UNLIM
SN10502DR	ACTIVE	SOIC	D	8	2500	Pb-Free (RoHS)	CU NIPDAU	Level-2-260C-1YEAR/ Level-1-220C-UNLIM
SN10503D	ACTIVE	SOIC	D	14	40	Pb-Free (RoHS)	CU NIPDAU	Level-2-260C-1YEAR/ Level-1-220C-UNLIM
SN10503DR	ACTIVE	SOIC	D	14	2500	Pb-Free (RoHS)	CU NIPDAU	Level-2-260C-1YEAR/ Level-1-220C-UNLIM
SN10503PWP	ACTIVE	HTSSOP	PWP	16	90	Green (RoHS & no Sb/Br)	CU NIPDAU	Level-2-260C-1 YEAR
SN10503PWPR	ACTIVE	HTSSOP	PWP	14	2000	Green (RoHS & no Sb/Br)	CU NIPDAU	Level-2-260C-1 YEAR

⁽¹⁾ The marketing status values are defined as follows:

ACTIVE: Product device recommended for new designs.

LIFEBUY: TI has announced that the device will be discontinued, and a lifetime-buy period is in effect.

NRND: Not recommended for new designs. Device is in production to support existing customers, but TI does not recommend using this part in a new design.

PREVIEW: Device has been announced but is not in production. Samples may or may not be available.

OBSOLETE: TI has discontinued the production of the device.

⁽²⁾ Eco Plan - May not be currently available - please check <http://www.ti.com/productcontent> for the latest availability information and additional product content details.

None: Not yet available Lead (Pb-Free).

Pb-Free (RoHS): TI's terms "Lead-Free" or "Pb-Free" mean semiconductor products that are compatible with the current RoHS requirements for all 6 substances, including the requirement that lead not exceed 0.1% by weight in homogeneous materials. Where designed to be soldered at high temperatures, TI Pb-Free products are suitable for use in specified lead-free processes.

Green (RoHS & no Sb/Br): TI defines "Green" to mean "Pb-Free" and in addition, uses package materials that do not contain halogens, including bromine (Br) or antimony (Sb) above 0.1% of total product weight.

⁽³⁾ MSL, Peak Temp. -- The Moisture Sensitivity Level rating according to the JEDEC industry standard classifications, and peak solder temperature.

Important Information and Disclaimer: The information provided on this page represents TI's knowledge and belief as of the date that it is provided. TI bases its knowledge and belief on information provided by third parties, and makes no representation or warranty as to the accuracy of such information. Efforts are underway to better integrate information from third parties. TI has taken and continues to take reasonable steps to provide representative and accurate information but may not have conducted destructive testing or chemical analysis on incoming materials and chemicals. TI and TI suppliers consider certain information to be proprietary, and thus CAS numbers and other limited information may not be available for release.

In no event shall TI's liability arising out of such information exceed the total purchase price of the TI part(s) at issue in this document sold by TI to Customer on an annual basis.

PWP (R-PDSO-G**) 20 PIN SHOWN

PowerPAD™ PLASTIC SMALL-OUTLINE PACKAGE

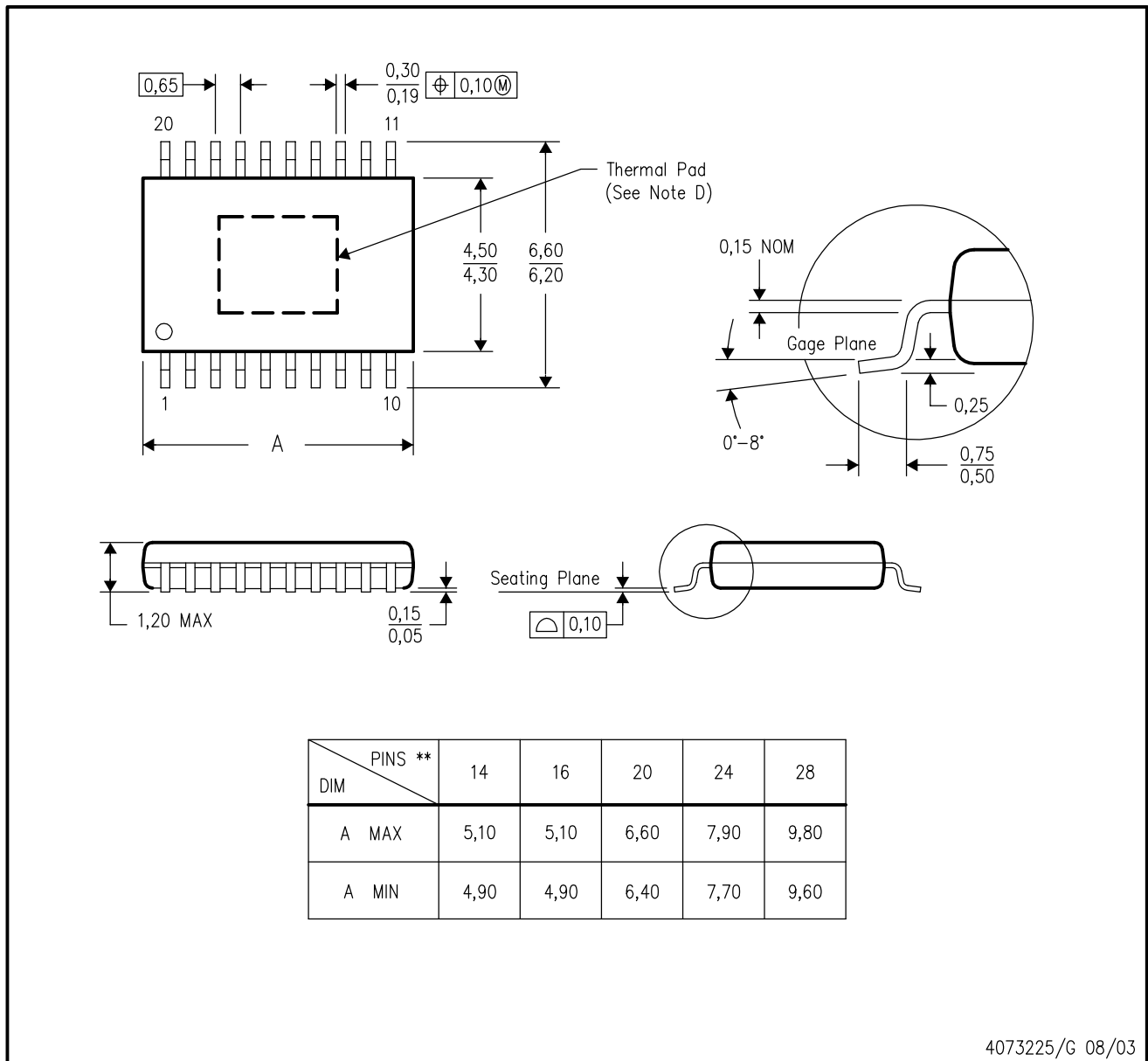

- NOTES:
- A. All linear dimensions are in millimeters.
 - B. This drawing is subject to change without notice.
 - C. Body dimensions do not include mold flash or protrusions.
 - D. This package is designed to be soldered to a thermal pad on the board. Refer to Technical Brief, PowerPad Thermally Enhanced Package, Texas Instruments Literature No. SLMA002 for information regarding recommended board layout. This document is available at www.ti.com <<http://www.ti.com>>.
 - E. Falls within JEDEC MO-153

PowerPAD is a trademark of Texas Instruments.

DBV (R-PDSO-G5)

PLASTIC SMALL-OUTLINE PACKAGE

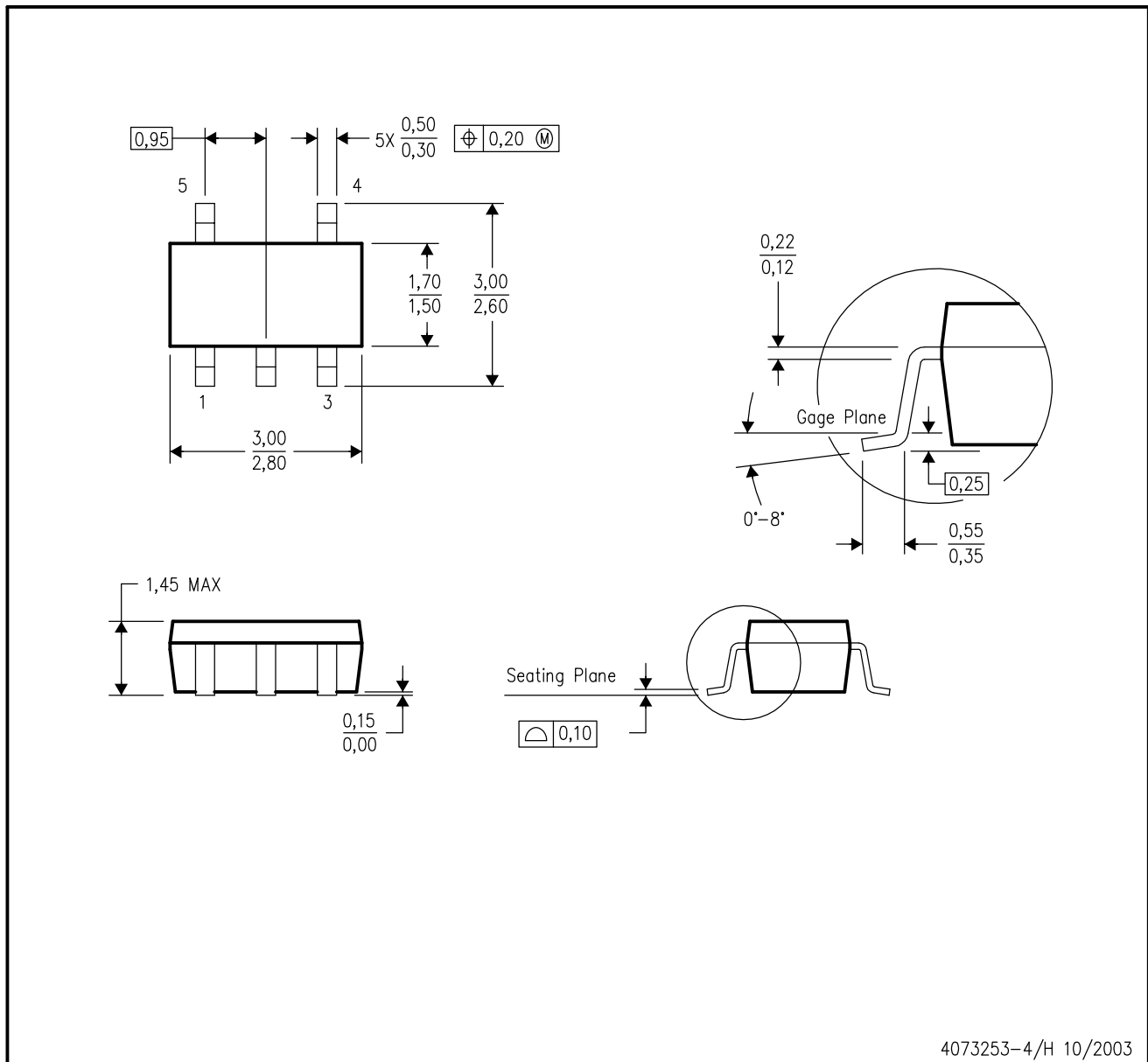

- NOTES:
- A. All linear dimensions are in millimeters.
 - B. This drawing is subject to change without notice.
 - C. Body dimensions do not include mold flash or protrusion.
 - D. Falls within JEDEC MO-178 Variation AA.

DGK (S-PDSO-G8)

PLASTIC SMALL-OUTLINE PACKAGE

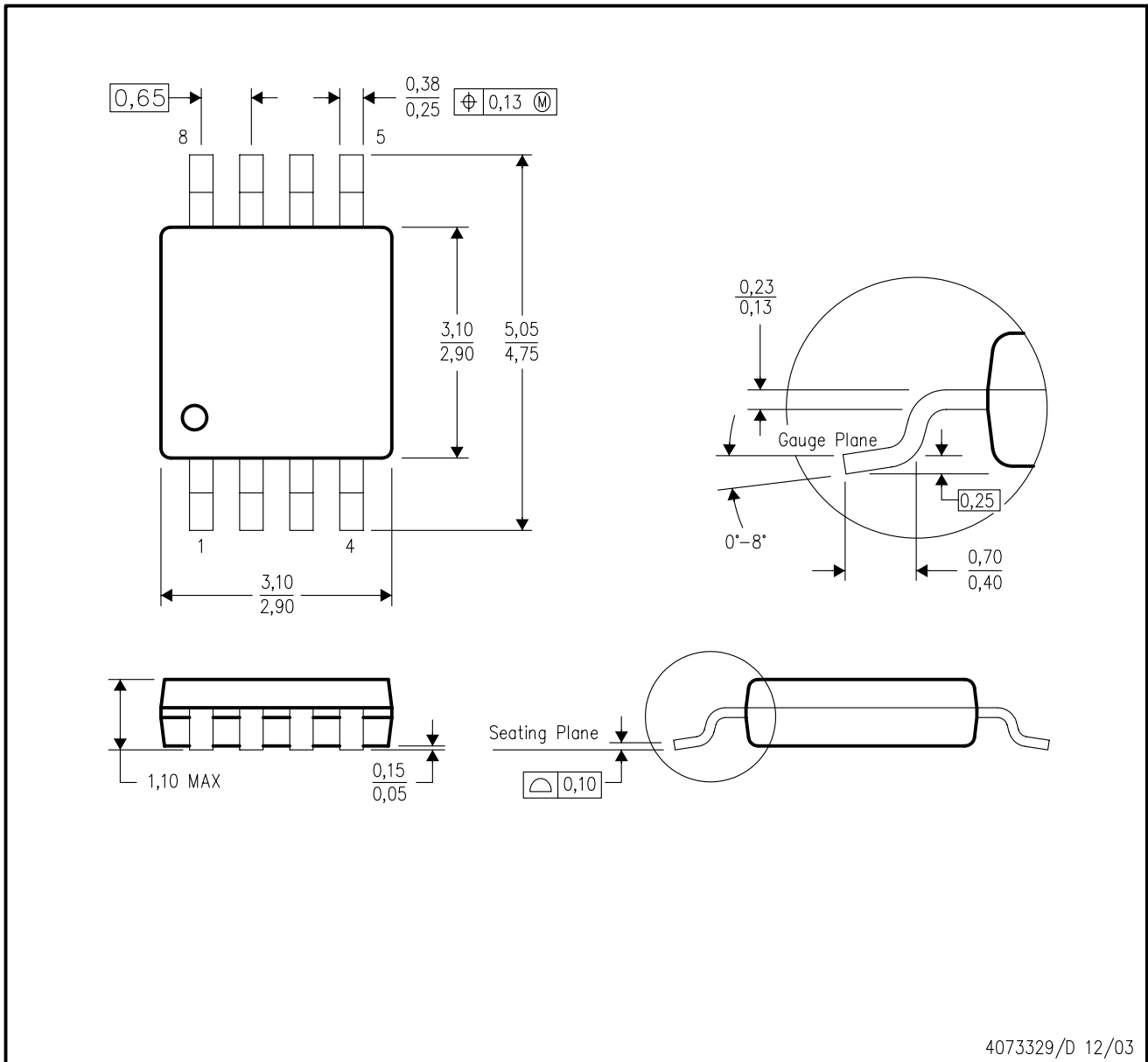

- NOTES:
- A. All linear dimensions are in millimeters.
 - B. This drawing is subject to change without notice.
 - C. Body dimensions do not include mold flash or protrusion.
 - D. Falls within JEDEC MO-187 variation AA.

MECHANICAL DATA

DGN (S-PDSO-G8)

PowerPAD™ PLASTIC SMALL-OUTLINE PACKAGE

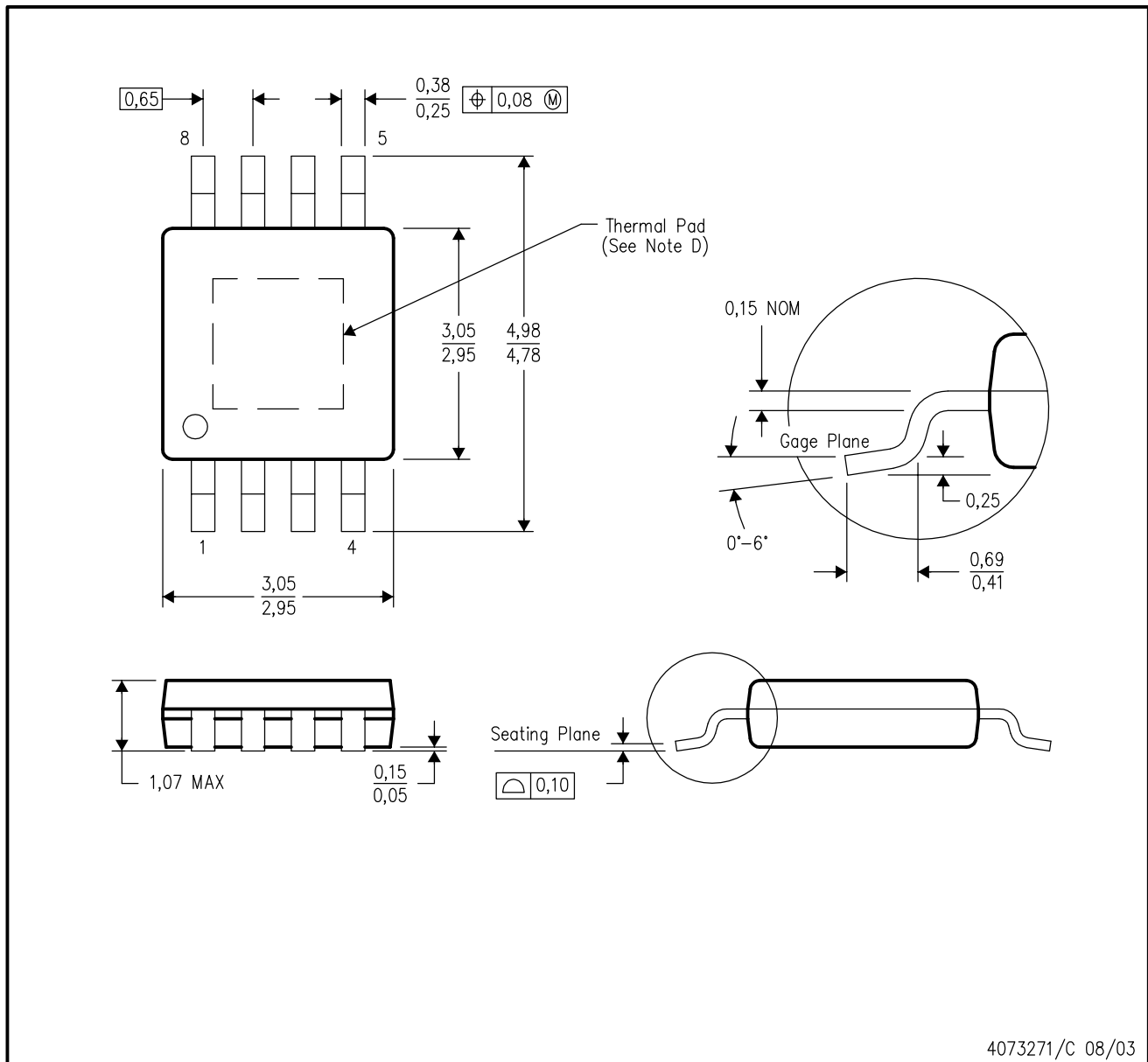

4073271/C 08/03

- NOTES:
- All linear dimensions are in millimeters.
 - This drawing is subject to change without notice.
 - Body dimensions do not include mold flash or protrusion.
 - This package is designed to be soldered to a thermal pad on the board. Refer to Technical Brief, PowerPad Thermally Enhanced Package, Texas Instruments Literature No. SLMA002 for information regarding recommended board layout. This document is available at www.ti.com <<http://www.ti.com>>.
 - Falls within JEDEC MO-187

PowerPAD is a trademark of Texas Instruments.

D (R-PDSO-G14)

PLASTIC SMALL-OUTLINE PACKAGE

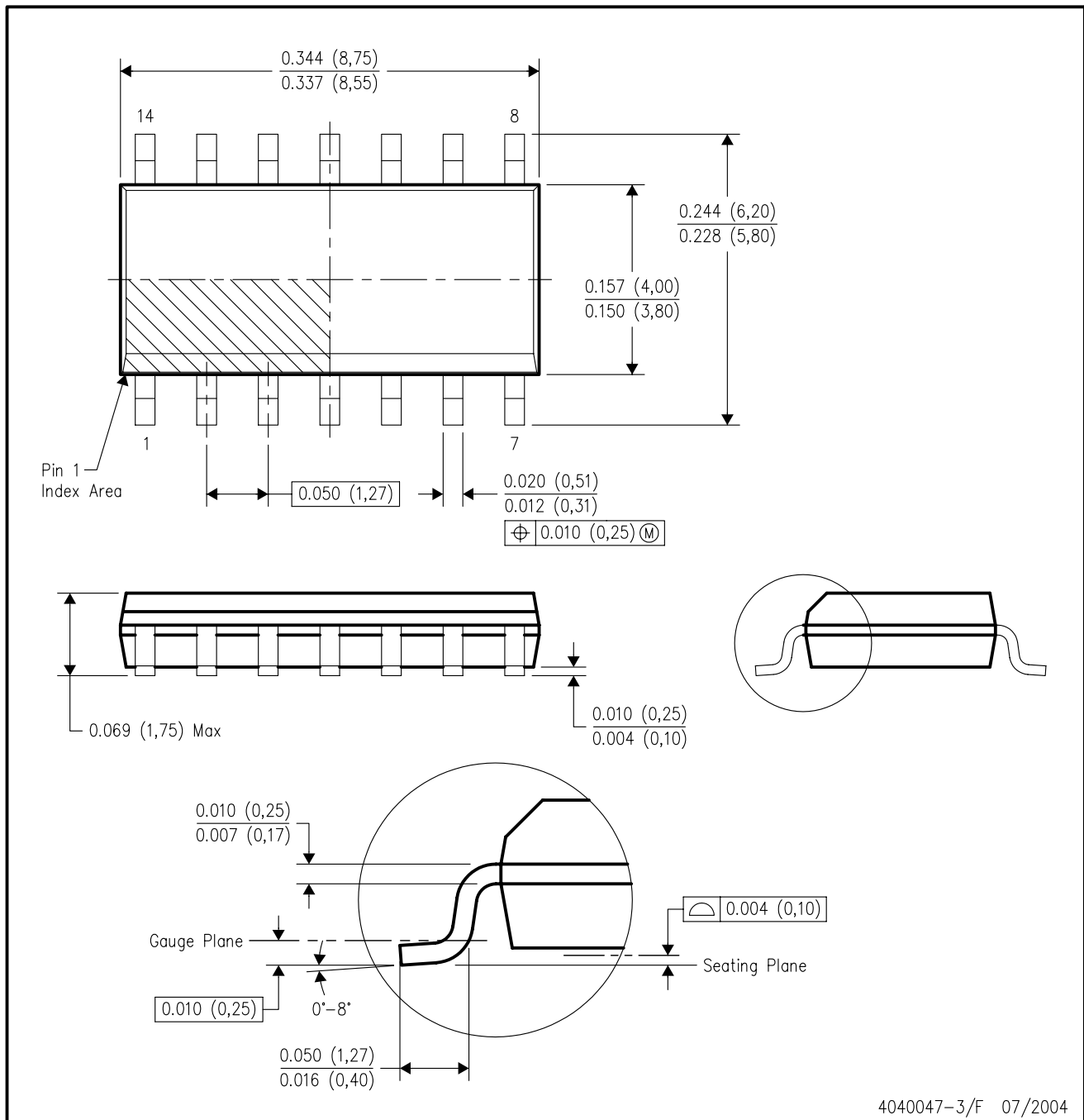

- NOTES:
- A. All linear dimensions are in inches (millimeters).
 - B. This drawing is subject to change without notice.
 - C. Body dimensions do not include mold flash or protrusion not to exceed 0.006 (0,15).
 - D. Falls within JEDEC MS-012 variation AB.

IMPORTANT NOTICE

Texas Instruments Incorporated and its subsidiaries (TI) reserve the right to make corrections, modifications, enhancements, improvements, and other changes to its products and services at any time and to discontinue any product or service without notice. Customers should obtain the latest relevant information before placing orders and should verify that such information is current and complete. All products are sold subject to TI's terms and conditions of sale supplied at the time of order acknowledgment.

TI warrants performance of its hardware products to the specifications applicable at the time of sale in accordance with TI's standard warranty. Testing and other quality control techniques are used to the extent TI deems necessary to support this warranty. Except where mandated by government requirements, testing of all parameters of each product is not necessarily performed.

TI assumes no liability for applications assistance or customer product design. Customers are responsible for their products and applications using TI components. To minimize the risks associated with customer products and applications, customers should provide adequate design and operating safeguards.

TI does not warrant or represent that any license, either express or implied, is granted under any TI patent right, copyright, mask work right, or other TI intellectual property right relating to any combination, machine, or process in which TI products or services are used. Information published by TI regarding third-party products or services does not constitute a license from TI to use such products or services or a warranty or endorsement thereof. Use of such information may require a license from a third party under the patents or other intellectual property of the third party, or a license from TI under the patents or other intellectual property of TI.

Reproduction of information in TI data books or data sheets is permissible only if reproduction is without alteration and is accompanied by all associated warranties, conditions, limitations, and notices. Reproduction of this information with alteration is an unfair and deceptive business practice. TI is not responsible or liable for such altered documentation.

Resale of TI products or services with statements different from or beyond the parameters stated by TI for that product or service voids all express and any implied warranties for the associated TI product or service and is an unfair and deceptive business practice. TI is not responsible or liable for any such statements.

Following are URLs where you can obtain information on other Texas Instruments products and application solutions:

Products		Applications	
Amplifiers	amplifier.ti.com	Audio	www.ti.com/audio
Data Converters	dataconverter.ti.com	Automotive	www.ti.com/automotive
DSP	dsp.ti.com	Broadband	www.ti.com/broadband
Interface	interface.ti.com	Digital Control	www.ti.com/digitalcontrol
Logic	logic.ti.com	Military	www.ti.com/military
Power Mgmt	power.ti.com	Optical Networking	www.ti.com/opticalnetwork
Microcontrollers	microcontroller.ti.com	Security	www.ti.com/security
		Telephony	www.ti.com/telephony
		Video & Imaging	www.ti.com/video
		Wireless	www.ti.com/wireless

Mailing Address: Texas Instruments
Post Office Box 655303 Dallas, Texas 75265