

SN54S140, SN74S140 DUAL 4-INPUT POSITIVE-NAND 50-OHM LINE DRIVERS

SDLS210 – DECEMBER 1983 – REVISED MARCH 1988

- Package Options Include Ceramic Chip Carriers and Flat Packages in Addition to Plastic and Ceramic DIPs
- Dependable Texas Instruments Quality and Reliability

description

These devices contain two independent 4-input positive-NAND 50-ohm line drivers. They perform the Boolean function $Y = \overline{ABCD}$.

The SN54S140 is characterized for operation over the full military temperature range of -55°C to 125°C . The SN74S140 is characterized for operation from 0°C to 70°C .

logic diagram (each driver)

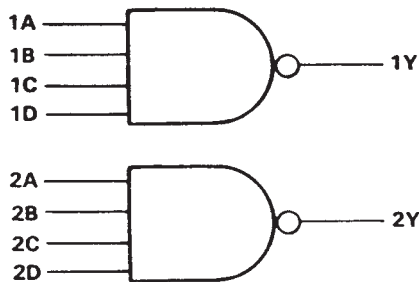

logic symbol†

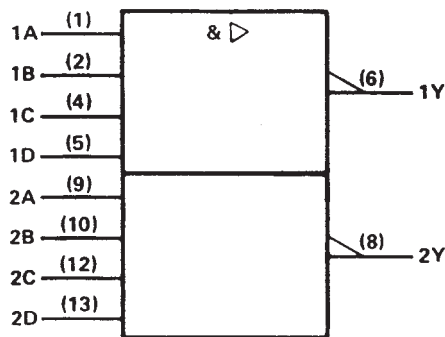

† This symbol is in accordance with ANSI/IEEE Std. 91-1984 and IEC Publication 617-12.

Pin numbers shown are for D, J, N, and W packages.

SN54S140 . . . J OR W PACKAGE SN74S140 . . . D OR N PACKAGE (TOP VIEW)

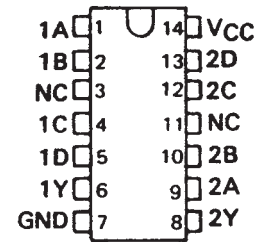

SN54S140 . . . FK PACKAGE (TOP VIEW)

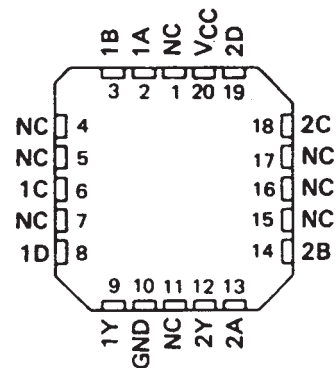

NC—No internal connection

SN54S140, SN74S140 DUAL 4-INPUT POSITIVE-NAND 50-OHM LINE DRIVERS

SDLS210 – DECEMBER 1983 – REVISED MARCH 1988

schematic (each driver)

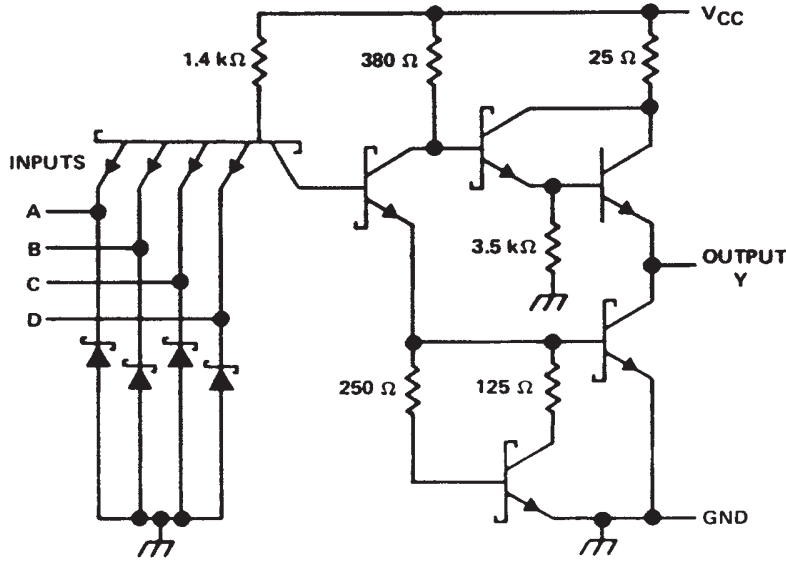

Resistor values shown are nominal.

absolute maximum ratings over operating free-air temperature range (unless otherwise noted)

Supply voltage, V_{CC} (see Note 1)	7 V
Input voltage	5.5 V
Operating free-air temperature range: SN54'	- 55°C to 125°C
SN74'	0°C to 70°C
Storage temperature range	- 65°C to 150°C

NOTE 1: Voltage values are with respect to network ground terminal.



POST OFFICE BOX 655303 • DALLAS, TEXAS 75265

SN54S140, SN74S140

DUAL 4-INPUT POSITIVE-NAND 50-OHM LINE DRIVERS

SDLS210 – DECEMBER 1983 – REVISED MARCH 1988

recommended operating conditions

	SN54S140			SN74S140			UNIT
	MIN	NOM	MAX	MIN	NOM	MAX	
V _{CC} Supply voltage	4.5	5	5.5	4.75	5	5.25	V
V _{IH} High-level input voltage	2			2			V
V _{IL} Low-level input voltage			0.8			0.8	V
I _{OH} High-level output current			-40			-40	mA
I _{OL} Low-level output current			60			60	mA
T _A Operating free-air temperature	-55		125	0		70	°C

electrical characteristics over recommended operating free-air temperature range (unless otherwise noted)

PARAMETER	TEST CONDITIONS†	SN54S140			SN74S140			UNIT
		MIN	TYP‡	MAX	MIN	TYP‡	MAX	
V _{IK}	V _{CC} = MIN, I _I = -18 mA			-1.2			-1.2	V
V _{OH}	V _{CC} = MIN, V _{IL} = 0.8 V, I _{OH} = -3 mA	2.5	3.4		2.7	3.4		V
	V _{CC} = MIN, V _{IL} = 0.5 V, R _O = 50 Ω to GND	2			2			
V _{OL}	V _{CC} = MIN, V _{IH} = 2 V, I _{OL} = 60 mA			0.5			0.5	V
I _I	V _{CC} = MAX, V _I = 5.5 V			1			1	mA
I _{IH}	V _{CC} = MAX, V _{IH} = 2.7 V			0.1			0.1	mA
I _{IL}	V _{CC} = MAX, V _{IL} = 0.5 V			-4			-4	mA
I _{OS} §	V _{CC} = MAX	-50		-225	-50		-225	mA
I _{CCH}	V _{CC} = MAX, V _I = 0 V		10	18		10	18	mA
I _{CCL}	V _{CC} = MAX, V _I = 4.5 V		25	44		25	44	mA

† For conditions shown as MIN or MAX, use the appropriate value specified under recommended operating conditions.

‡ All typical values are at V_{CC} = 5 V, T_A = 25°C.

§ Not more than one output should be shorted at a time, and the duration of the short circuit should not exceed 100 milliseconds.

switching characteristics, V_{CC} = 5 V, T_A = 25°C (see note 2)

PARAMETER	FROM (INPUT)	TO (OUTPUT)	TEST CONDITIONS		MIN	TYP	MAX	UNIT
t _{PLH}	Any	Y	R _L = 93 Ω,	C _L = 50 pF	4	6.5		ns
t _{PHL}					4	6.5		ns
t _{PLH}			R _L = 93 Ω,	C _L = 150 pF	6			ns
t _{PHL}					6			ns

NOTE 2: Load circuits and voltage waveforms are shown in Section 1.

IMPORTANT NOTICE

Texas Instruments and its subsidiaries (TI) reserve the right to make changes to their products or to discontinue any product or service without notice, and advise customers to obtain the latest version of relevant information to verify, before placing orders, that information being relied on is current and complete. All products are sold subject to the terms and conditions of sale supplied at the time of order acknowledgement, including those pertaining to warranty, patent infringement, and limitation of liability.

TI warrants performance of its semiconductor products to the specifications applicable at the time of sale in accordance with TI's standard warranty. Testing and other quality control techniques are utilized to the extent TI deems necessary to support this warranty. Specific testing of all parameters of each device is not necessarily performed, except those mandated by government requirements.

CERTAIN APPLICATIONS USING SEMICONDUCTOR PRODUCTS MAY INVOLVE POTENTIAL RISKS OF DEATH, PERSONAL INJURY, OR SEVERE PROPERTY OR ENVIRONMENTAL DAMAGE ("CRITICAL APPLICATIONS"). TI SEMICONDUCTOR PRODUCTS ARE NOT DESIGNED, AUTHORIZED, OR WARRANTED TO BE SUITABLE FOR USE IN LIFE-SUPPORT DEVICES OR SYSTEMS OR OTHER CRITICAL APPLICATIONS. INCLUSION OF TI PRODUCTS IN SUCH APPLICATIONS IS UNDERSTOOD TO BE FULLY AT THE CUSTOMER'S RISK.

In order to minimize risks associated with the customer's applications, adequate design and operating safeguards must be provided by the customer to minimize inherent or procedural hazards.

TI assumes no liability for applications assistance or customer product design. TI does not warrant or represent that any license, either express or implied, is granted under any patent right, copyright, mask work right, or other intellectual property right of TI covering or relating to any combination, machine, or process in which such semiconductor products or services might be or are used. TI's publication of information regarding any third party's products or services does not constitute TI's approval, warranty or endorsement thereof.