

LOW-POWER RS-485 TRANSCEIVER

FEATURES

- Meets or Exceeds the Requirements of the TIA/EIA-485A Standard
- Low Quiescent Power
 - < 0.3 mA Active Mode
 - 1 nA Shutdown Mode
- Driver Outputs Optimized for Low EMI at Signaling Rates up to 200 kbps
- 1/8 Unit Load—Up to 256 Nodes on a Bus
- Bus-Pin ESD Protection Exceeds 16 kV
- Industry-Standard SN75176 Footprint
- Failsafe Receiver (Bus Open, Bus Shorted, Bus Idle)

APPLICATIONS

- Energy Meter Networks
- Power Inverters
- Industrial Automation
- Building Automation Networks
- Industrial Process Control
- Battery-Powered Applications
- Telecommunications Equipment

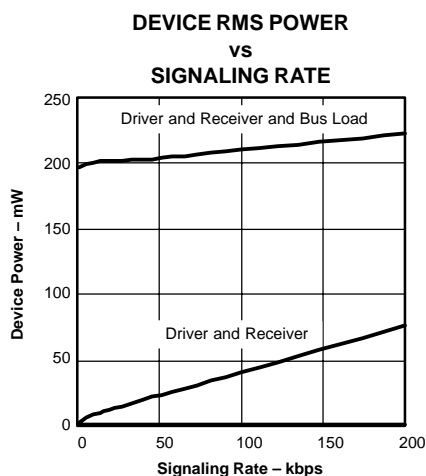

DESCRIPTION

This device is a half-duplex transceiver designed for RS-485 data bus networks. Powered by a 5-V supply, it is fully compliant with the TIA/EIA-485A standard. With controlled output transition times, this device is suitable for signaling rates up to 200 kbps over long twisted-pair cables. The device is designed to operate with very low supply current, typically less than 0.6 mA, exclusive of the load. When in the inactive shutdown mode, the supply current drops to a few nanoamps, making these devices ideal for power-sensitive applications.

The wide common-mode range and high ESD protection levels of these devices make them suitable for demanding applications such as energy meter networks, electrical inverters, status/command signals across telecom racks, cabled chassis interconnects, and industrial automation networks where noise tolerance is essential. The SN65HVD3082E and SN75HVD3082E match the industry-standard footprint of the SN75176.

FUNCTIONAL DIAGRAM (POSITIVE LOGIC)

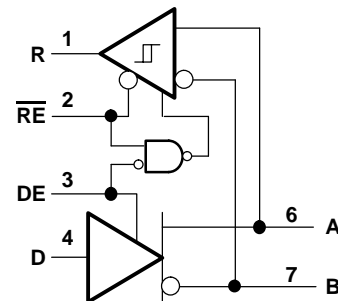

Please be aware that an important notice concerning availability, standard warranty, and use in critical applications of Texas Instruments semiconductor products and disclaimers thereto appears at the end of this data sheet.



These devices have limited built-in ESD protection. The leads should be shorted together or the device placed in conductive foam during storage or handling to prevent electrostatic damage to the MOS gates.

ORDERING INFORMATION

T _A	PLASTIC DUAL-IN-LINE	PLASTIC SMALL OUTLINE†
0°C to 70°C	SN75HVD3082EP Marked as 75HVD3082	SN75HVD3082ED Marked as VN3082
-40°C to 85°C	SN65HVD3082EP Marked as 65HVD3082	SN65HVD3082ED Marked as VP3082

(1) The D package is available taped and reeled. Add an R suffix to the device type (i.e., SN65HVD3082EDR).

ABSOLUTE MAXIMUM RATINGS

over operating free-air temperature range unless otherwise noted⁽¹⁾ (2)

		UNITS	
Supply voltage range, V _{CC}		-0.5 V to 7 V	
Voltage range at A or B		-9 V to 14 V	
Voltage range at any logic pin		-0.3 V to V _{CC} + 0.3 V	
Continuous total power dissipation		Refer to Package Dissipation Table	
Electrostatic discharge	Bus terminals and GND	HBM ⁽³⁾	±16 kV
		All pins	4 kV
	Charged-Device Model ⁽⁴⁾ all pins		1 kV
Voltage input range, transient pulse, A and B, through 100 Ω (see Figure 13)		-50 V to 50 V	
Storage temperature range		-65°C to 120°C	

(1) Stresses beyond those listed under “absolute maximum ratings” may cause permanent damage to the device. These are stress ratings only, and functional operation of the device at these or any other conditions beyond those indicated under “recommended operating conditions” is not implied. Exposure to absolute-maximum-rated conditions for extended periods may affect device reliability.

(2) All voltage values, except differential I/O bus voltages, are with respect to network ground terminal.

(3) Tested in accordance with JEDEC Standard 22, Test Method A114-A

(4) Tested in accordance with JEDEC Standard 22, Test Method C101.

RECOMMENDED OPERATING CONDITIONS⁽¹⁾

		MIN	MAX	UNIT
Supply voltage, V _{CC}		4.5	5.5	V
Input voltage at any bus terminal (separately or common mode), V _I		-7	12	V
High-level input voltage (D, DE, or \overline{RE} inputs), V _{IH}		2	V _{CC}	V
Low-level input voltage (D, DE, or \overline{RE} inputs), V _{IL}		0	0.8	V
Differential input voltage, V _{ID}		-12	12	V
Output current, I _O	Driver	-60	60	mA
	Receiver	-8	8	
Operating free-air temperature, T _A	SN65HVD3082E	-40	85	°C
	SN75HVD3082E	0	70	

(1) The algebraic convention, in which the least positive (most negative) limit is designated as minimum, is used in this data sheet.

PACKAGE DISSIPATION RATINGS

PACKAGE	$T_A \leq 25^\circ\text{C}$ POWER RATING	DERATING FACTOR ABOVE $T_A = 25^\circ\text{C}$	$T_A = 70^\circ\text{C}$ POWER RATING	$T_A = 85^\circ\text{C}$ POWER RATING
D	710 mW	5.7 mW/ $^\circ\text{C}$	455 mW	369 mW
P	1000 mW	8.0 mW/ $^\circ\text{C}$	640 mW	520 mW

FUNCTION TABLE

DRIVER				RECEIVER		
INPUT D	ENABLE DE	OUTPUTS	OUTPUTS	DIFFERENTIAL INPUTS $V_{ID} = V_A - V_B$	ENABLE DE	OUTPUT R
		A	B			
H	H	H	L	$V_{ID} \leq -0.2\text{ V}$	L	L
L	H	L	H	$-0.2\text{ V} < V_{ID} < -0.01\text{ V}$	L	?
X	L	Z	Z	$-0.01\text{ V} \leq V_{ID}$	L	H
Open	H	H	L	X	H	Z
X	Open	Z	Z	Open circuit	L	H
				Short circuit	L	H
				X	Open	Z

NOTE: H= high level; L= low level; Z= high impedance; X= irrelevant; ? = indeterminate

PIN ASSIGNMENTS

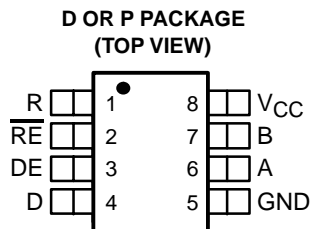

EQUIVALENT INPUT AND OUTPUT SCHEMATIC DIAGRAMS

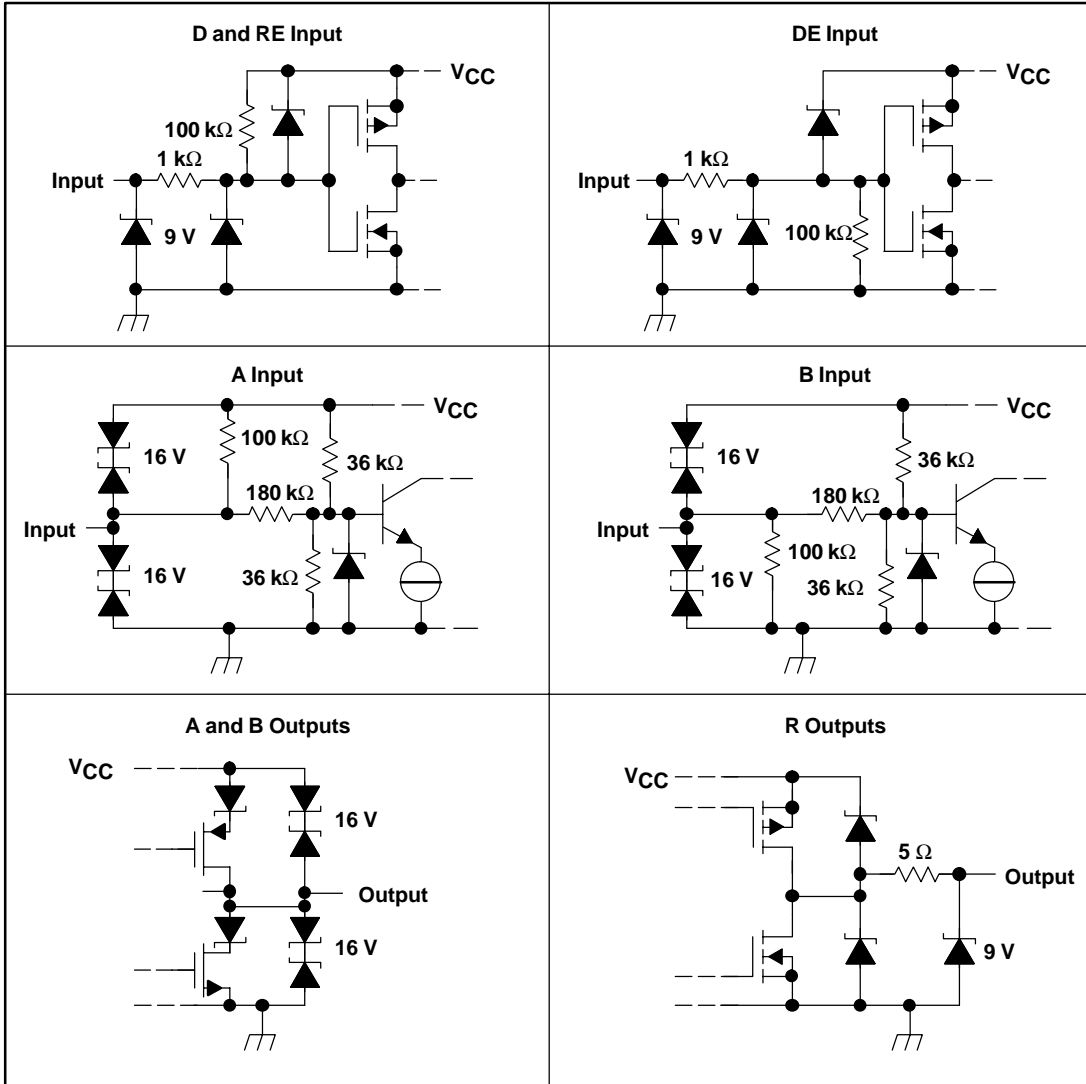

SUPPLY CURRENT

over recommended operating conditions unless otherwise noted

PARAMETER		TEST CONDITIONS		MIN	TYP ⁽¹⁾	MAX	UNIT
I _{CC}	Driver and receiver enabled	D at 0 or V _{CC} or open, No load	DE at V _{CC} , RE at 0 V,		425	900	μA
	Driver enabled, receiver disabled	D at 0 or V _{CC} or open, No load	DE at V _{CC} , RE at V _{CC}		330	600	μA
	Receiver enabled, driver disabled	D at 0 or V _{CC} or open, No load	DE at 0 V, RE at 0 V,		300	600	μA
	Driver and receiver disabled	D at V _{CC} or open,	DE at 0 V, RE at V _{CC}		0.001	2	μA

⁽¹⁾ All typical values are at 25°C and with a 5-V supply.

DRIVER ELECTRICAL CHARACTERISTICS

over recommended operating conditions unless otherwise noted

PARAMETER		TEST CONDITIONS		MIN	TYP ⁽¹⁾	MAX	UNIT
V _{OD}	Differential output voltage	I _O = 0, No load		3	4.3		V
		R _L = 54 Ω, See Figure 1		1.5	2.3		
		V _{TEST} = -7 V to 12 V, See Figure 2		1.5			
ΔV _{OD}	Change in magnitude of differential output voltage	See Figure 1 and Figure 2		-0.2	0	0.2	V
V _{OC(SS)}	Steady-state common-mode output voltage	See Figure 3		1	2.6	3	V
ΔV _{OC(SS)}	Change in steady-state common-mode output voltage			-0.1	0	0.1	
V _{OC(PP)}		See Figure 3			500		mV
I _{OZ}	High-impedance output current	See receiver input currents					μA
I _I	Input current	D, DE		-100		100	μA
I _{OS}	Short-circuit output current	-7 V ≤ V _O ≤ 12 V, See Figure 7		-250		250	mA

⁽¹⁾ All typical values are at 25°C and with a 5-supply.

DRIVER SWITCHING CHARACTERISTICS

over recommended operating conditions unless otherwise noted

PARAMETER		TEST CONDITIONS		MIN	TYP	MAX	UNIT	
t _{PLH}	Propagation delay time, low-to-high-level output	R _L = 54 Ω, C _L = 50 pF, See Figure 4			0.7	1.3	μs	
t _{PHL}	Propagation delay time, high-to-low-level output				0.7	1.3		
t _r	Differential output signal rise time				0.5	0.9		1.5
t _f	Differential output signal fall time				0.5	0.9		1.5
t _{sk(p)}	Pulse skew (t _{PHL} - t _{PLH})				0.02	0.2		
t _{PZH}	Propagation delay time, high-impedance-to-high-level output	R _L = 110 Ω, RE at 0 V, See Figure 5			3	7	μs	
t _{PHZ}	Propagation delay time, high-level-to-high-impedance output			0.07	0.2			
t _{PZL}	Propagation delay time, high-impedance-to-low-level output	R _L = 110 Ω, RE at 0 V See Figure 6			2	7	μs	
t _{P LZ}	Propagation delay time, low-level-to-high-impedance output			0.09	0.2			
t _{PZH(SHDN)}	Propagation delay time, shutdown-to-high-level output	R _L = 110 Ω, RE at V _{CC} , See Figure 5			4	7	μs	
t _{PZL(SHDN)}	Propagation delay time, shutdown-to-low-level output	R _L = 110 Ω, RE at V _{CC} , See Figure 6			3	7	μs	

RECEIVER ELECTRICAL CHARACTERISTICS

over recommended operating conditions unless otherwise noted

PARAMETER		TEST CONDITIONS	MIN	TYP ⁽¹⁾	MAX	UNIT
V _{IT+}	Positive-going input threshold voltage	I _O = -8 mA		-85	-10	mV
V _{IT-}	Negative-going input threshold voltage	I _O = 8 mA	-200	-115		mV
V _{hys}	Hysteresis voltage (V _{IT+} - V _{IT-})			30		mV
V _{OH}	High-level output voltage	V _{ID} = 200 mV, I _{OH} = -8 mA, See Figure 8	4	4.6		V
V _{OL}	Low-level output voltage	V _{ID} = -200 mV, I _{OH} = 8 mA, See Figure 8		0.15	0.4	V
I _{OZ}	High-impedance-state output current	V _O = 0 to V _{CC}	-1		1	μA
I _I	Bus input current	Other input at 0 V	V _{IH} = 12 V, V _{CC} = 5 V	0.04	0.1	mA
			V _{IH} = 12 V, V _{CC} = 0	0.06	0.125	
			V _{IH} = -7 V, V _{CC} = 5 V	-0.1	-0.04	
			V _{IH} = -7 V, V _{CC} = 0	-0.05	-0.03	
I _{IH}	High-level input current (\overline{RE})	V _{IH} = 2 V	-60	-30		μA
I _{IL}	Low-level input current (\overline{RE})	V _{IL} = 0.8 V	-60	-30		μA
C _{diff}	Differential input capacitance	V _I = 0.4 sin(4E6πt) + 0.5 V, DE at 0 V		7		pF

(1) All typical values are at 25°C and with a 5-V supply.

RECEIVER SWITCHING CHARACTERISTICS

over recommended operating conditions unless otherwise noted

PARAMETER		TEST CONDITIONS	MIN	TYP	MAX	UNIT
t _{PLH}	Propagation delay time, low-to-high-level output	V _{ID} = -1.5 V to 1.5 V, C _L = 15 pF, See Figure 9		75	200	ns
t _{PHL}	Propagation delay time, high-to-low-level output			79	200	
t _{sk(p)}	Pulse skew (t _{PHL} - t _{PLH})			4	30	
t _r	Output signal rise time			1.5	3	ns
t _f	Output signal fall time		1.8	3		
t _{PZH}	Output enable time to high level	C _L = 15 pF, DE at 3 V, See Figure 10 and Figure 11		5	50	ns
t _{PZL}	Output enable time to low level			10	50	
t _{PHZ}	Output enable time from high level			5	50	
t _{PLZ}	Output enable time from low level			8	50	
t _{PZH(SHDN)}	Propagation delay time, shutdown-to-high-level output	C _L = 15 pF, DE at 0 V, See Figure 12		1.6	3.5	μs
t _{PZL(SHDN)}	Propagation delay time, shutdown-to-low-level output			1.7	3.5	

PARAMETER MEASUREMENT INFORMATION

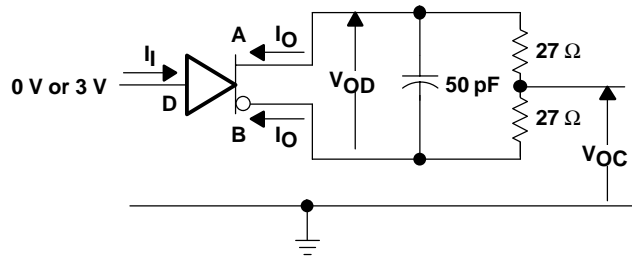

Figure 1. Driver Test Circuit, V_{OD} and V_{OC} Without Common-Mode Loading

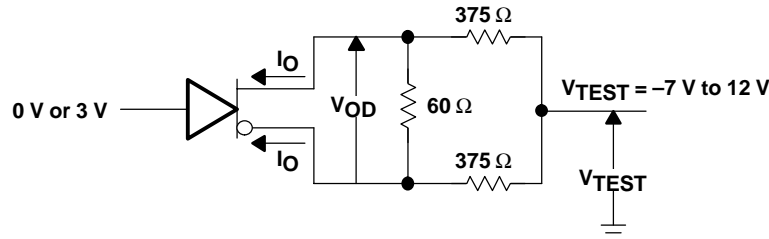

Figure 2. Driver Test Circuit, V_{OD} With Common-Mode Loading

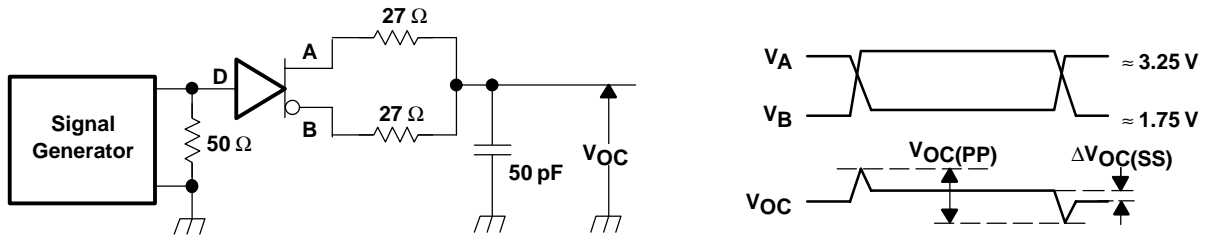

Figure 3. Driver V_{OC} Test Circuit and Waveforms

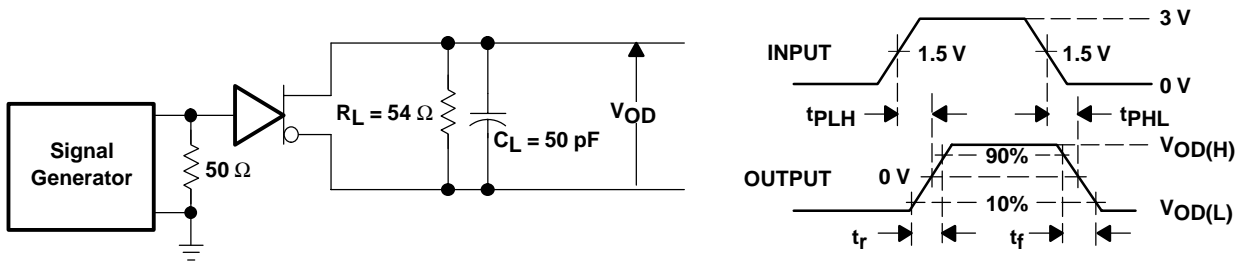

Figure 4. Driver Switching Test Circuit and Waveforms

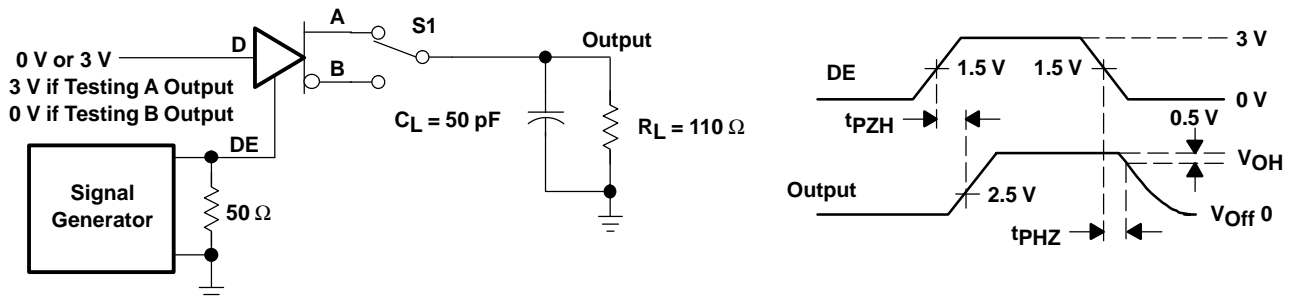

Figure 5. Driver Enable/Disable Test Circuit and Waveforms, High Output

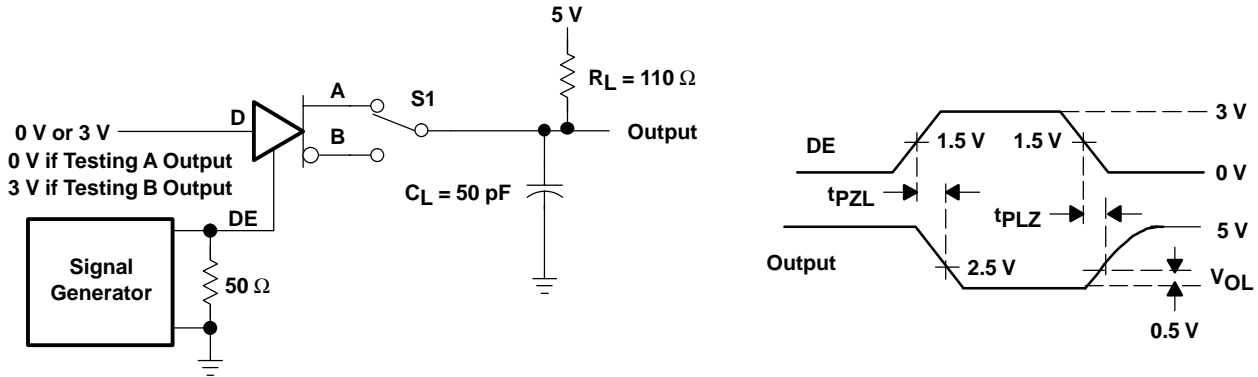

Figure 6. Driver Enable/Disable Test Circuit and Waveforms, Low Output

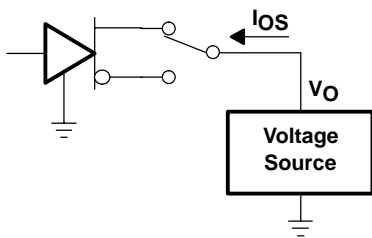

Figure 7. Driver Short-Circuit Test

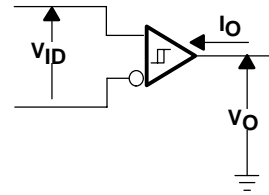

Figure 8. Receiver DC Parameter Definitions

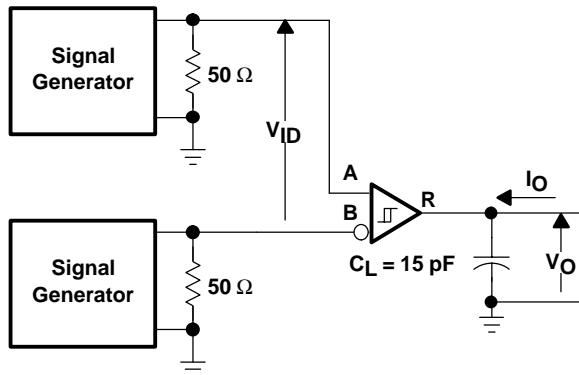

Figure 9. Receiver Switching Test Circuit and Waveforms

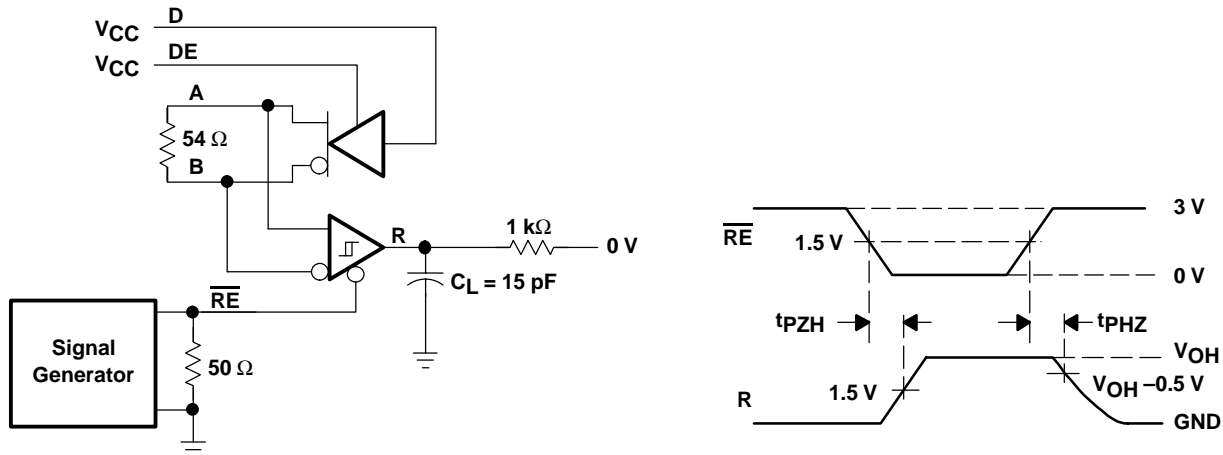

Figure 10. Receiver Enable/Disable Test Circuit and Waveforms, Data Output High

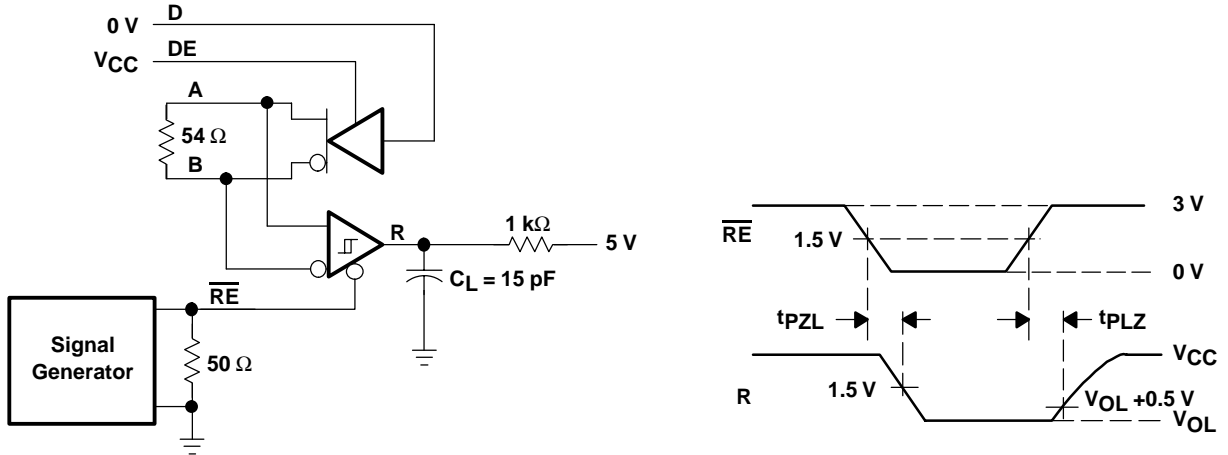

Figure 11. Receiver Enable/Disable Test Circuit and Waveforms, Data Output Low

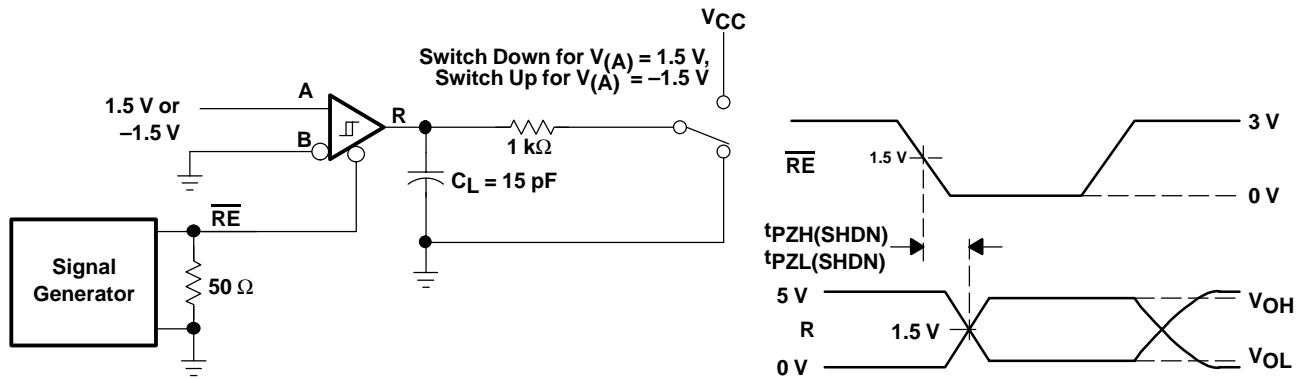

Figure 12. Receiver Enable From Shutdown Test Circuit and Waveforms

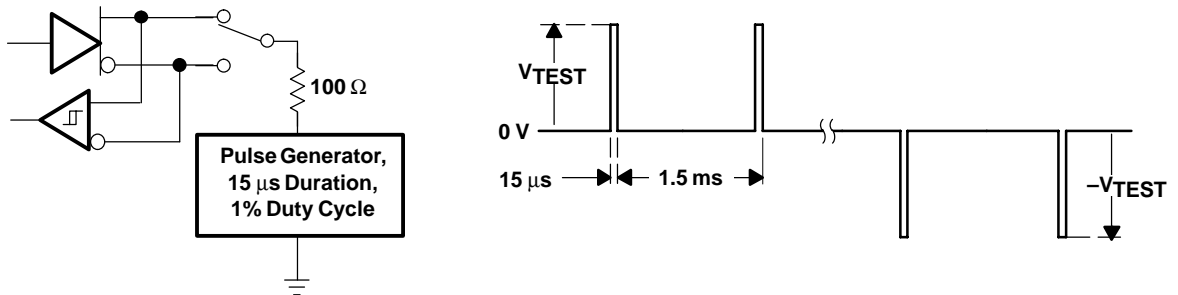

Figure 13. Test Circuit and Waveforms, Transient Over-Voltage Test

TYPICAL CHARACTERISTICS

BUS INPUT CURRENT
vs
BUS INPUT VOLTAGE

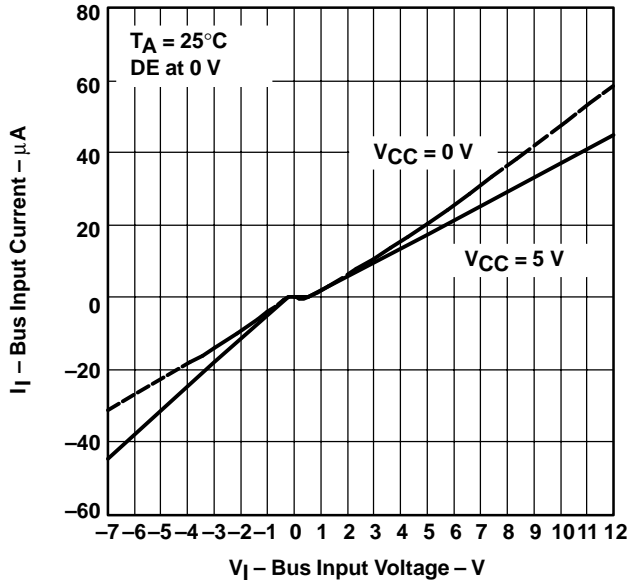

Figure 14

SUPPLY CURRENT
vs
SIGNALING FREQUENCY

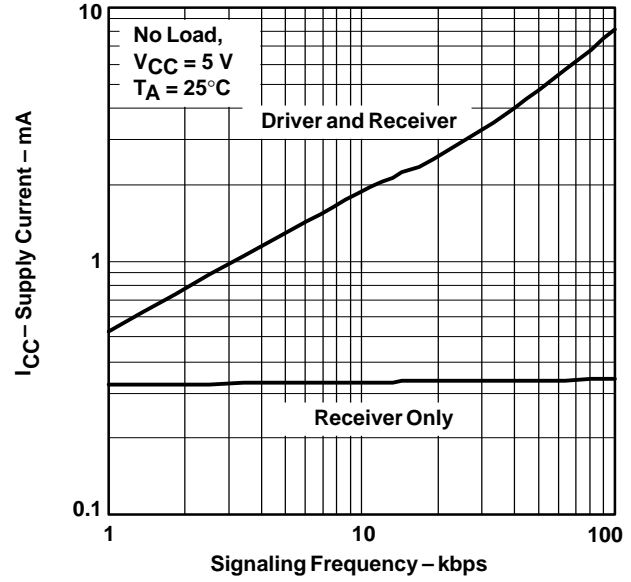

Figure 15

DRIVER DIFFERENTIAL OUTPUT VOLTAGE
vs
DRIVER LOAD CURRENT

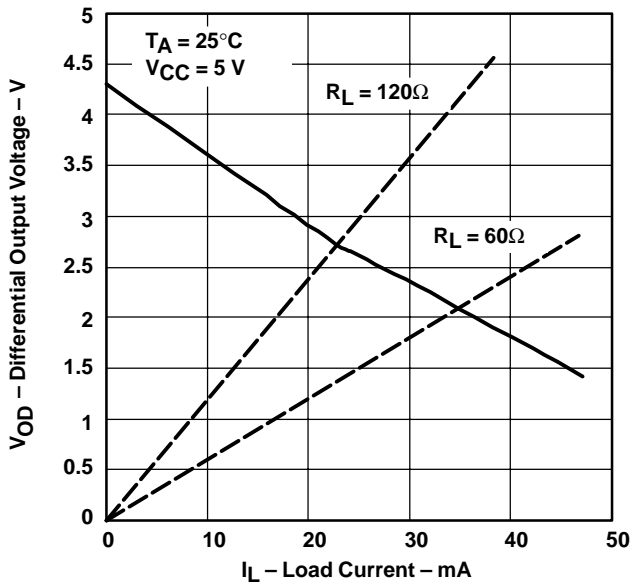

Figure 16

RECEIVER OUTPUT VOLTAGE
vs
DIFFERENTIAL INPUT VOLTAGE

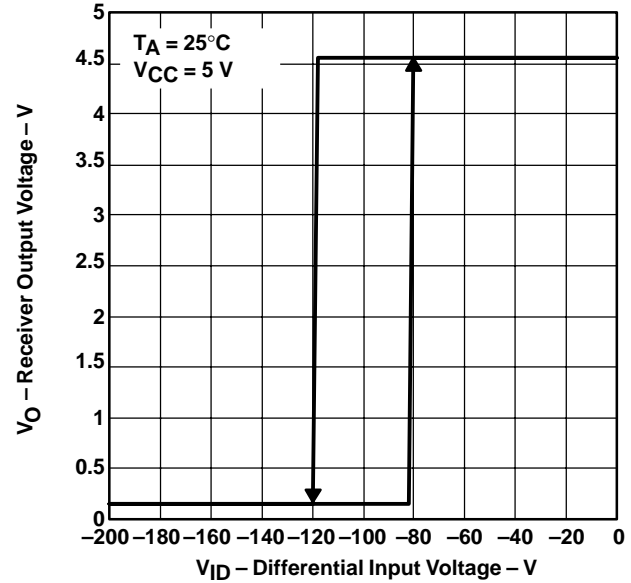
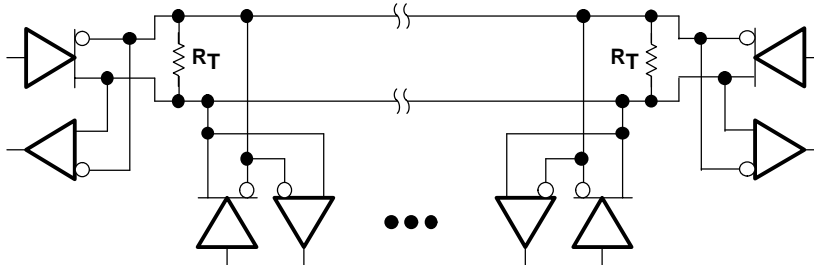

Figure 17

APPLICATION INFORMATION



NOTE: The line should be terminated at both ends with its characteristic impedance ($R_T = Z_0$). Stub lengths off the main line should be kept as short as possible.

Figure 18. Typical Application Circuit

POWER USAGE IN AN RS-485 TRANSCEIVER

Power consumption is a concern in many applications. Power supply current is delivered to the bus load as well as to the transceiver circuitry. For a typical RS-485 bus configuration, the load that an active driver must drive consists of all of the receiving nodes, plus the termination resistors at each end of the bus.

The load presented by the receiving nodes depends on the input impedance of the receiver. The TIA/EIA-485-A standard defines a unit load as allowing up to 1 mA. With up to 32 unit loads allowed on the bus, the total current supplied to all receivers can be as high as 32 mA. The HVD3082E is rated as a 1/8 unit load device. As shown in Figure 14, the bus input current is less than 1/8 mA, allowing up to 256 nodes on a single bus.

The current in the termination resistors depends on the differential bus voltage. The standard requires active drivers to produce at least 1.5 V of differential signal. For a bus terminated with one standard 120- Ω resistor at each end, this sums to 25 mA in the termination resistors whenever the bus is active. Typically the HVD3082E can drive more than 25 mA to a 60 Ω load, resulting in a differential output voltage higher than the minimum required by the standard. (See Figure 16.)

Overall, the total load current can typically be 60 mA to a loaded RS-485 bus. This is in addition to the current required by the transceiver itself; the HVD3082E circuitry typically requires only about 0.4 mA with both driver and receiver enabled, and only 0.3 mA with either the driver enabled or with the receiver enabled. In low-power shutdown mode, neither the driver nor receiver is active, and the supply current is very low.

Supply current increases with signaling rate due to capacitive effects. (See Figure 15.) The capacitive elements are found both internal to the transceiver and in the external load. The external load capacitance is often modeled as a lumped 50 pF, as shown in the test circuit schematics (Figures 4–6). This 50 pF represents the effect of PWB trace capacitance, losses in cable media, and the capacitance of the receiving nodes. The internal capacitance is due to the transceiver circuitry, and is typically 7 pF for the HVD3082E.

LOW-POWER SHUTDOWN MODE

When both the driver and receiver are disabled (\overline{DE} low and \overline{RE} high) the device is in shutdown mode. If the enable inputs are in this state for less than 60 ns, the device does not enter shutdown mode. This guards against inadvertently entering shutdown mode during driver/receiver enabling. Only when the enable inputs are held in this state for 300 ns or more, the device is assured to be in shutdown mode. In this low-power shutdown mode, most internal circuitry is powered down, and the supply current is typically 1 nA. When either the driver or the receiver is re-enabled, the internal circuitry becomes active.

If only the driver is re-enabled (\overline{DE} transitions to high) the driver outputs are driven according to the D input after the enable times given by $t_{PZH(SHDN)}$ and $t_{PZL(SHDN)}$ in the driver switching characteristics. If the D input is open when the driver is enabled, the driver outputs defaults to A high and B low, in accordance with the driver failsafe feature.

If only the receiver is re-enabled (\overline{RE} transitions to low) the receiver output is driven according to the state of the bus inputs (A and B) after the enable times given by $t_{PZH(SHDN)}$ and $t_{PZL(SHDN)}$ in the receiver switching characteristics. If there is no valid state on the bus the receiver responds as described in the failsafe operation section.

If both the receiver and driver are re-enabled simultaneously, the receiver output is driven according to the state of the bus inputs (A and B) and the driver output is driven according to the D input. Note that the state of the active driver affects the inputs to the receiver. Therefore, the receiver outputs are valid as soon as the driver outputs are valid.

MECHANICAL DATA

D (R-PDSO-G**)

PLASTIC SMALL-OUTLINE PACKAGE

8 PINS SHOWN

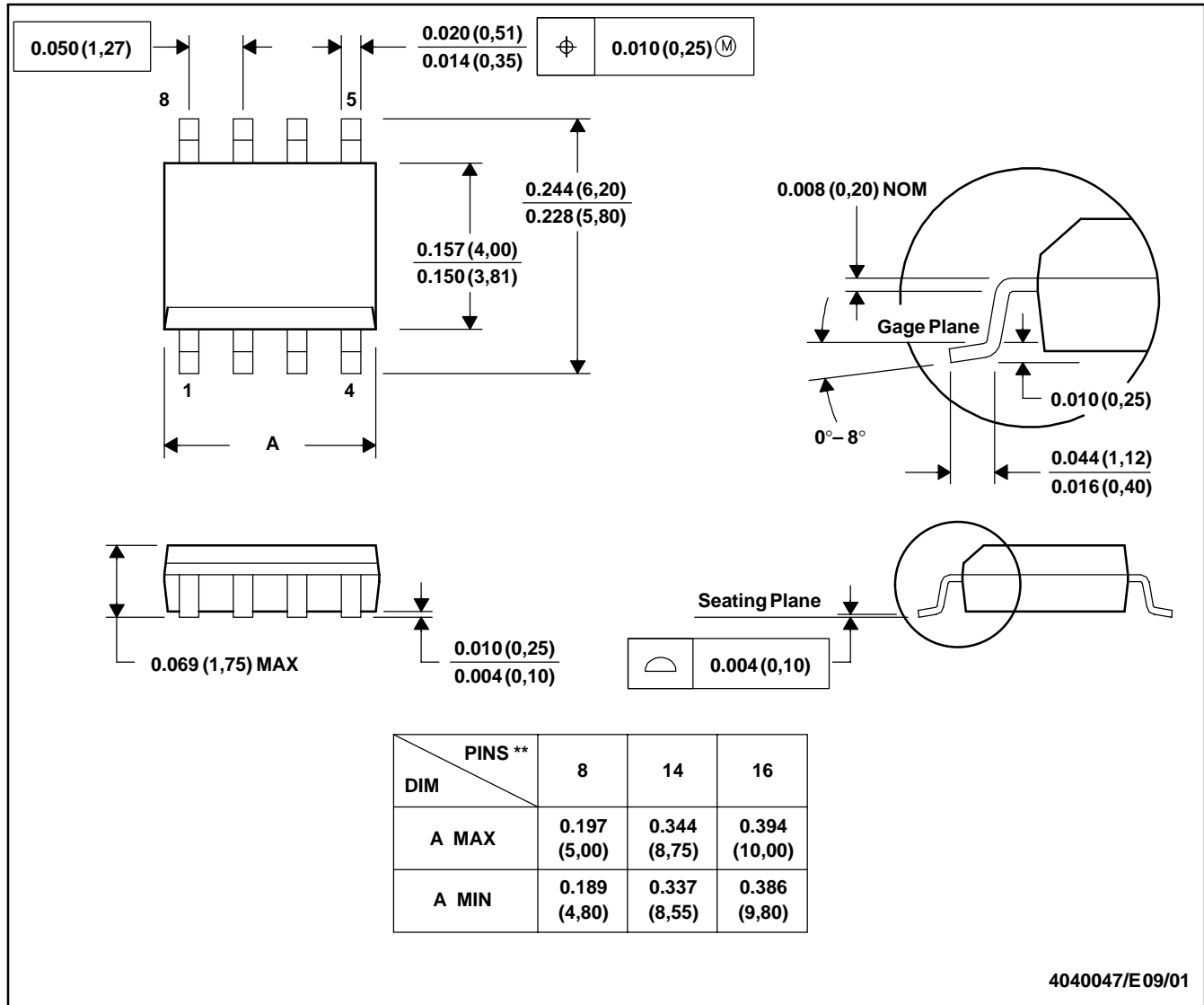

- NOTES: A. All linear dimensions are in inches (millimeters).
 B. This drawing is subject to change without notice.
 C. Body dimensions do not include mold flash or protrusion, not to exceed 0.006 (0,15).
 D. Falls within JEDEC MS-012

MECHANICAL DATA

P (R-PDIP-T8)

PLASTIC DUAL-IN-LINE

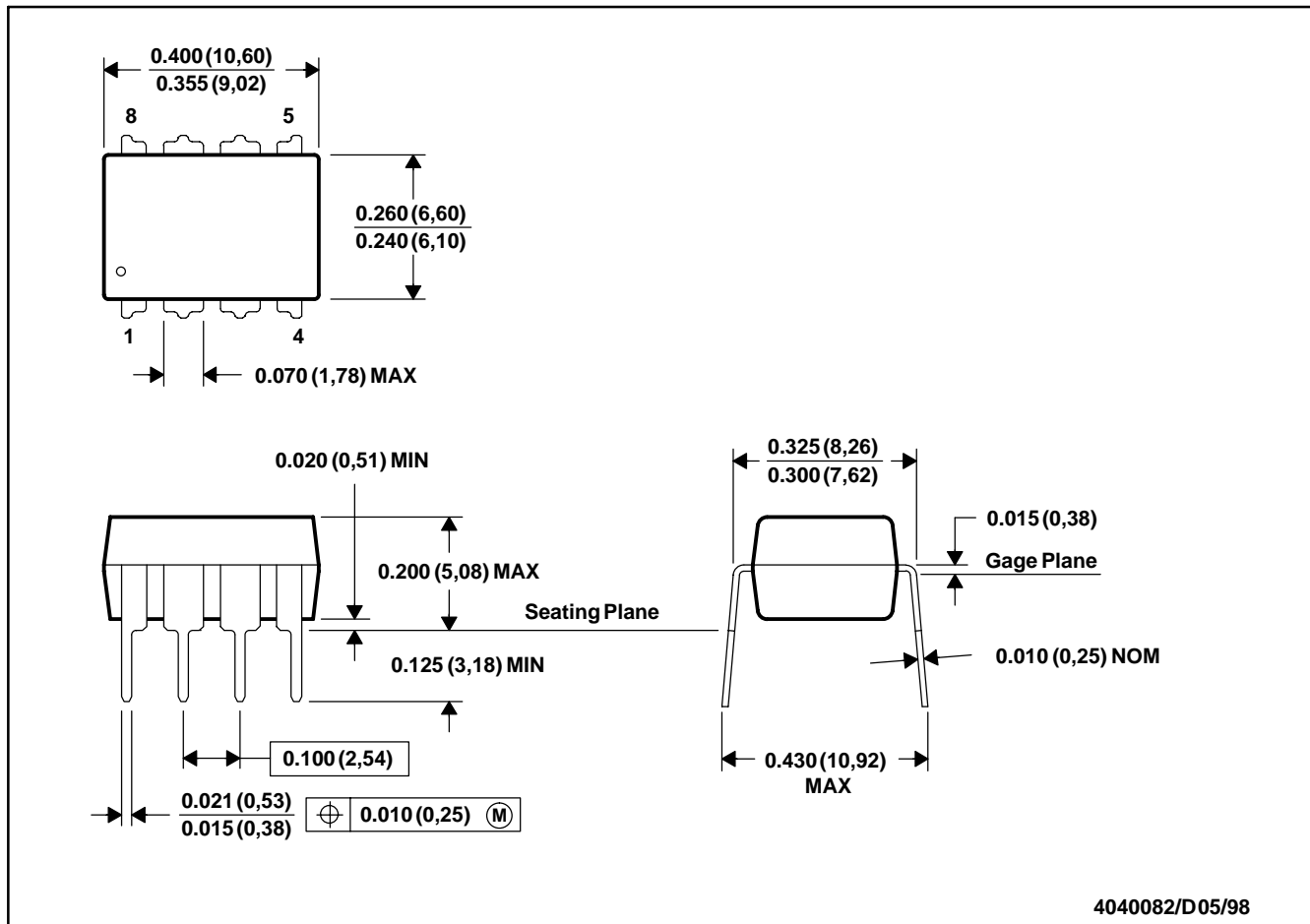

- NOTES: A. All linear dimensions are in inches (millimeters).
 B. This drawing is subject to change without notice.
 C. Falls within JEDEC MS-001

P (R-PDIP-T8)

PLASTIC DUAL-IN-LINE



- NOTES: A. All linear dimensions are in inches (millimeters).
 B. This drawing is subject to change without notice.
 C. Falls within JEDEC MS-001

For the latest package information, go to http://www.ti.com/sc/docs/package/pkg_info.htm

D (R-PDSO-G**)

PLASTIC SMALL-OUTLINE PACKAGE

8 PINS SHOWN

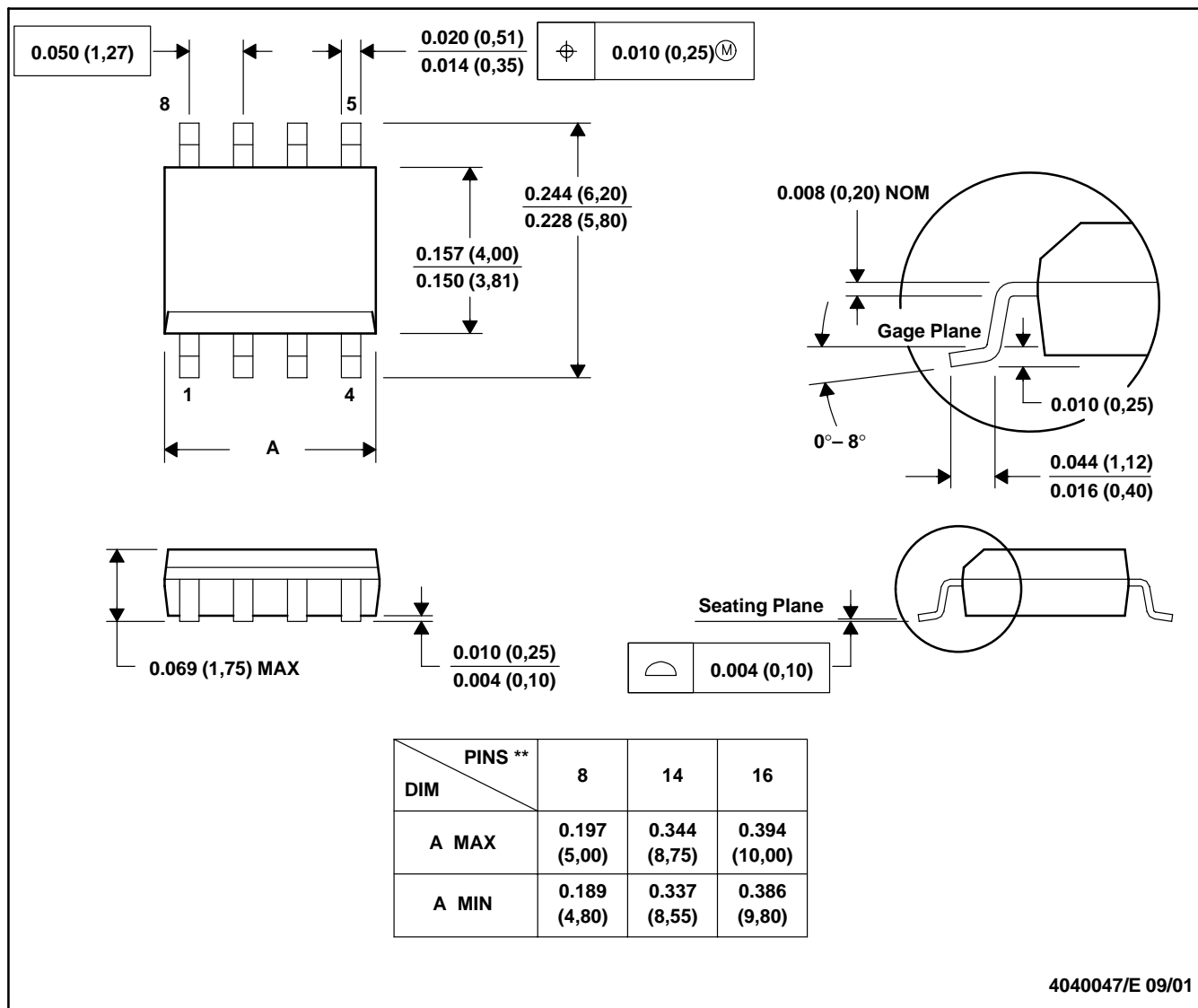

4040047/E 09/01

- NOTES: A. All linear dimensions are in inches (millimeters).
 B. This drawing is subject to change without notice.
 C. Body dimensions do not include mold flash or protrusion, not to exceed 0.006 (0,15).
 D. Falls within JEDEC MS-012

IMPORTANT NOTICE

Texas Instruments Incorporated and its subsidiaries (TI) reserve the right to make corrections, modifications, enhancements, improvements, and other changes to its products and services at any time and to discontinue any product or service without notice. Customers should obtain the latest relevant information before placing orders and should verify that such information is current and complete. All products are sold subject to TI's terms and conditions of sale supplied at the time of order acknowledgment.

TI warrants performance of its hardware products to the specifications applicable at the time of sale in accordance with TI's standard warranty. Testing and other quality control techniques are used to the extent TI deems necessary to support this warranty. Except where mandated by government requirements, testing of all parameters of each product is not necessarily performed.

TI assumes no liability for applications assistance or customer product design. Customers are responsible for their products and applications using TI components. To minimize the risks associated with customer products and applications, customers should provide adequate design and operating safeguards.

TI does not warrant or represent that any license, either express or implied, is granted under any TI patent right, copyright, mask work right, or other TI intellectual property right relating to any combination, machine, or process in which TI products or services are used. Information published by TI regarding third-party products or services does not constitute a license from TI to use such products or services or a warranty or endorsement thereof. Use of such information may require a license from a third party under the patents or other intellectual property of the third party, or a license from TI under the patents or other intellectual property of TI.

Reproduction of information in TI data books or data sheets is permissible only if reproduction is without alteration and is accompanied by all associated warranties, conditions, limitations, and notices. Reproduction of this information with alteration is an unfair and deceptive business practice. TI is not responsible or liable for such altered documentation.

Resale of TI products or services with statements different from or beyond the parameters stated by TI for that product or service voids all express and any implied warranties for the associated TI product or service and is an unfair and deceptive business practice. TI is not responsible or liable for any such statements.

Mailing Address:

Texas Instruments
Post Office Box 655303
Dallas, Texas 75265