

SN75LBC179, SN65LBC179, SN65LBC179Q LOW-POWER DIFFERENTIAL LINE DRIVER AND RECEIVER PAIRS

SLLS173D – JANUARY 1994 – REVISED JUNE 2000

- Designed for High-Speed Multipoint Data Transmission Over Long Cables
- Operates With Pulse Widths as Low as 30 ns
- Low Supply Current . . . 5 mA Max
- Meets or Exceeds the Standard Requirements of ANSI RS-485 and ISO 8482:1987(E)
- Common-Mode Voltage Range of -7 V to 12 V
- Positive- and Negative-Output Current Limiting
- Driver Thermal Shutdown Protection
- Pin Compatible With the SN75179B

description

The SN65LBC179, SN65LBC179Q, and SN75LBC179 differential driver and receiver pairs are monolithic integrated circuits designed for bidirectional data communication over long cables that take on the characteristics of transmission lines. They are balanced, or differential, voltage mode devices that meet or exceed the requirements of industry standards ANSI RS-485 and ISO 8482:1987(E). Both devices are designed using TI's proprietary LinBiCMOS™ with the low power consumption of CMOS and the precision and robustness of bipolar transistors in the same circuit.

The SN65LBC179, SN65LBC179Q, and SN75LBC179 combine a differential line driver and differential line receiver and operate from a single 5-V supply. The driver differential outputs and the receiver differential inputs are connected to separate terminals for full-duplex operation and are designed to present minimum loading to the bus when powered off ($V_{CC} = 0$). These parts feature a wide common-mode voltage range making them suitable for point-to-point or multipoint data bus applications. The devices also provide positive- and negative-current limiting and thermal shutdown for protection from line fault conditions. The line driver shuts down at a junction temperature of approximately 172°C .

D OR P PACKAGE
(TOP VIEW)

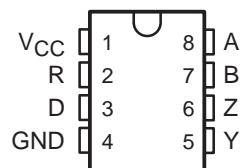

Function Tables

DRIVER

INPUT D	OUTPUTS	
	Y	Z
H	H	L
L	L	H

RECEIVER

DIFFERENTIAL INPUTS A-B	OUTPUT R
$V_{ID} \geq 0.2\text{ V}$	H
$-0.2\text{ V} < V_{ID} < 0.2\text{ V}$?
$V_{ID} \leq -0.2\text{ V}$	L
Open circuit	H

H = high level, L = low level,
? = indeterminate

logic symbol†

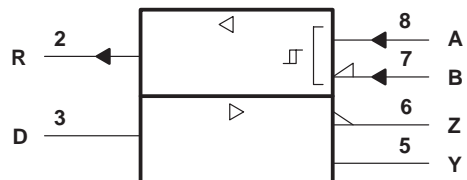

† This symbol is in accordance with ANSI/IEEE Std 91-1984 and IEC Publication 617-12.

logic diagram (positive logic)

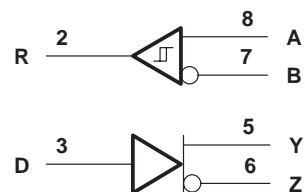

Please be aware that an important notice concerning availability, standard warranty, and use in critical applications of Texas Instruments semiconductor products and disclaimers thereto appears at the end of this data sheet.

LinBiCMOS is a trademark of Texas Instruments.

PRODUCTION DATA information is current as of publication date. Products conform to specifications per the terms of Texas Instruments standard warranty. Production processing does not necessarily include testing of all parameters.

**TEXAS
INSTRUMENTS**

POST OFFICE BOX 655303 • DALLAS, TEXAS 75265

Copyright © 2000, Texas Instruments Incorporated

SN75LBC179, SN65LBC179, SN65LBC179Q LOW-POWER DIFFERENTIAL LINE DRIVER AND RECEIVER PAIRS

SLLS173D – JANUARY 1994 – REVISED JUNE 2000

description (continued)

The SN65LBC179, SN65LBC179Q, and SN75LBC179 are available in the 8-pin dual-in-line and small-outline packages. The SN75LBC179 is characterized for operation over the commercial temperature range of 0°C to 70°C. The SN65LBC179 is characterized over the industrial temperature range of -40°C to 85°C. The SN65LBC179Q is characterized over the extended industrial or automotive temperature range of -40°C to 125°C.

schematics of inputs and outputs

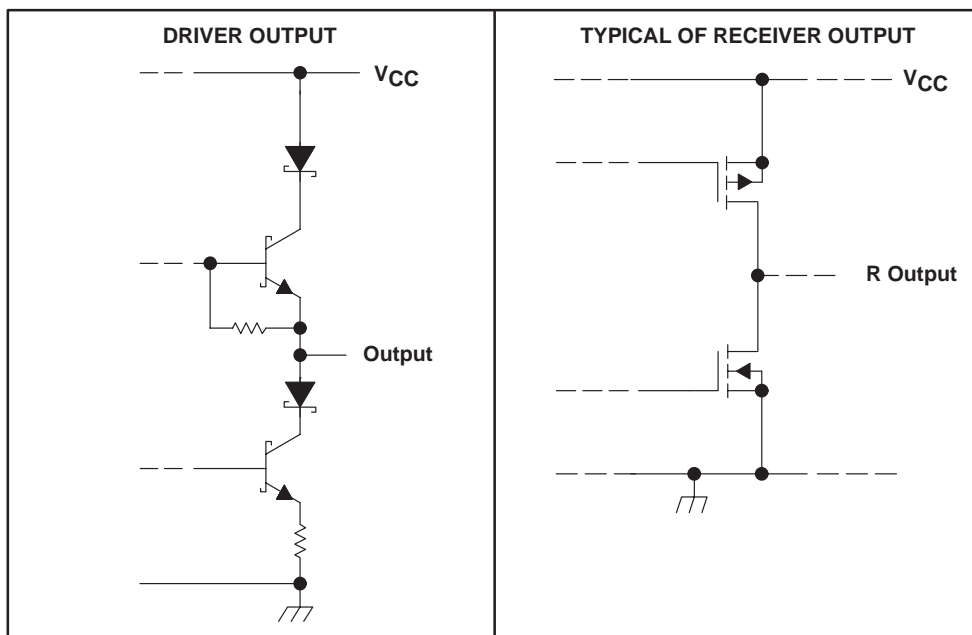
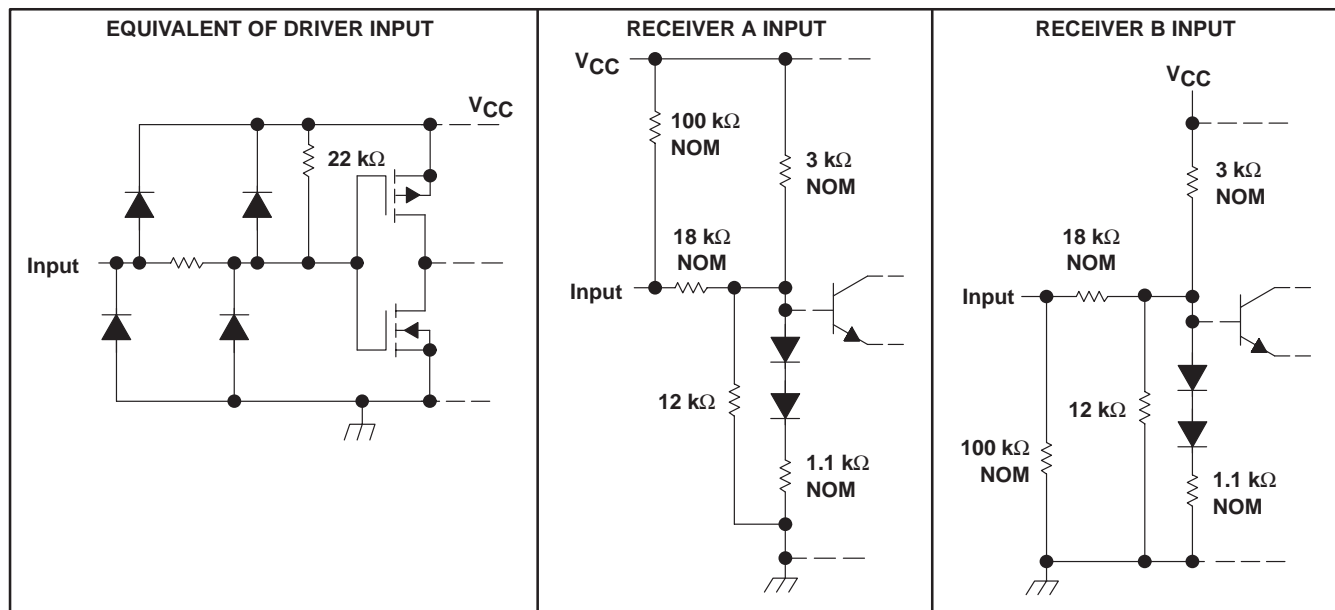

SN75LBC179, SN65LBC179, SN65LBC179Q LOW-POWER DIFFERENTIAL LINE DRIVER AND RECEIVER PAIRS

SLLS173D – JANUARY 1994 – REVISED JUNE 2000

absolute maximum ratings over operating free-air temperature range (unless otherwise noted)†

Supply voltage range, V_{CC}	–0.3 V to 7 V
Voltage range at A, B, Y, or Z (see Note 1)	–10 V to 15 V
Voltage range at D or R (see Note 1)	–0.3 V to $V_{CC} + 0.5$ V
Continuous total power dissipation (see Note 2)	Internally limited
Total power dissipation	See Dissipation Rating Table
Operating free-air temperature range, T_A : SN65LBC179	–40°C to 85°C
SN65LBC179Q	–40°C to 125°C
SN75LBC179	0°C to 70°C
Storage temperature range, T_{stg}	–65°C to 150°C
Lead temperature 1,6 mm (1/16 inch) from case for 10 seconds	260°C

† Stresses beyond those listed under “absolute maximum ratings” may cause permanent damage to the device. These are stress ratings only, and functional operation of the device at these or any other conditions beyond those indicated under “recommended operating conditions” is not implied. Exposure to absolute-maximum-rated conditions for extended periods may affect device reliability.

- NOTES: 1. All voltage values are with respect to GND.
 2. The maximum operating junction temperature is internally limited. Uses the dissipation rating table to operate below this temperature.

DISSIPATION RATING TABLE

PACKAGE	$T_A \leq 25^\circ\text{C}$ POWER RATING	DERATING FACTOR ABOVE $T_A = 25^\circ\text{C}$	$T_A = 70^\circ\text{C}$ POWER RATING	$T_A = 85^\circ\text{C}$ POWER RATING
D	725 mW	5.8 mW/°C	464 mW	377 mW
P	1100 mW	8.8 mW/°C	704 mW	572 mW

recommended operating conditions

		MIN	NOM	MAX	UNIT
Supply voltage, V_{CC}		4.75	5	5.25	V
High-level input voltage, V_{IH}	D	2			V
Low-level input voltage, V_{IL}	D			0.8	V
Differential input voltage, V_{ID}		–6‡		6	V
Voltage at any bus terminal (separately or common-mode), V_O , V_I , or V_{IC}	A, B, Y, or Z	–7		12	V
High-level output current, I_{OH}	Y or Z			–60	mA
	R			–8	
Low-level output current, I_{OL}	Y or Z			60	mA
	R			8	
Operating free-air temperature, T_A	SN65LBC179	–40		85	°C
	SN65LBC179Q	–40		125	
	SN75LBC179	0		70	

‡ The algebraic convention, in which the least positive (most negative) limit is designated as minimum, is used in this data sheet for differential input voltage, voltage at any bus terminal (separately or common mode), operating temperature, input threshold voltage, and common-mode output voltage.



SN75LBC179, SN65LBC179, SN65LBC179Q LOW-POWER DIFFERENTIAL LINE DRIVER AND RECEIVER PAIRS

SLLS173D – JANUARY 1994 – REVISED JUNE 2000

DRIVER SECTION

electrical characteristics over recommended operating conditions (unless otherwise noted)

PARAMETER		TEST CONDITIONS		MIN	TYP†	MAX	UNIT
V _{IK}	Input clamp voltage	I _I = -18 mA				-1.5	V
V _{OD}	Differential output voltage (see Note 3)	R _L = 54 Ω, See Figure 1	SN65LBC179, SN65LBC179Q	1.1	2.2	5	V
			SN75LBC179	1.5	2.2	5	
		R _L = 60 Ω, See Figure 2	SN65LBC179, SN65LBC179Q	1.1	2.2	5	
			SN75LBC179	1.5	2.2	5	
Δ V _{OD}	Change in magnitude of differential output voltage (see Note 4)	See Figures 1 and 2				±0.2	V
V _{OC}	Common-mode output voltage	R _L = 54 Ω, See Figure 1		1	2.5	3	V
Δ V _{OC}	Change in magnitude of common-mode output voltage (see Note 4)					±0.2	V
I _O	Output current with power off	V _{CC} = 0, V _O = -7 V to 12 V				±100	μA
I _{IH}	High-level input current	V _I = 2.4 V				-100	μA
I _{IL}	Low-level input current	V _I = 0.4 V				-100	μA
I _{OS}	Short-circuit output current	-7 V ≤ V _O ≤ 12 V				±250	mA
I _{CC}	Supply current	No load	SN65LBC179, SN75LBC179		4.2	5	mA
			SN65LBC179Q		4.2	7	mA

† All typical values are at V_{CC} = 5 V and T_A = 25°C.

NOTES: 3. The minimum V_{OD} specification of the SN65179 may not fully comply with ANSI RS-485 at operating temperatures below 0°C. System designers should take the possibly lower output signal into account in determining the maximum signal transmission distance.

4. Δ|V_{OD}| and Δ|V_{OC}| are the changes in the steady-state magnitude of V_{OD} and V_{OC}, respectively, that occur when the input is changed from a high level to a low level.

switching characteristics, V_{CC} = 5 V, T_A = 25°C

PARAMETER		TEST CONDITIONS		MIN	MAX	UNIT
t _{d(OD)}	Differential-output delay time	R _L = 54 Ω, See Figure 3		7	18	ns
t _{t(OD)}	Differential transition time				5	20



POST OFFICE BOX 655303 • DALLAS, TEXAS 75265

SN75LBC179, SN65LBC179, SN65LBC179Q LOW-POWER DIFFERENTIAL LINE DRIVER AND RECEIVER PAIRS

SLLS173D – JANUARY 1994 – REVISED JUNE 2000

RECEIVER SECTION

electrical characteristics over recommended operating conditions (unless otherwise noted)

PARAMETER		TEST CONDITIONS	MIN	TYP	MAX	UNIT
V_{IT+}	Positive-going input threshold voltage	$I_O = -8 \text{ mA}$			0.2	V
V_{IT-}	Negative-going input threshold voltage	$I_O = 8 \text{ mA}$	-0.2			V
V_{hys}	Hysteresis voltage ($V_{IT+} - V_{IT-}$)			45		mV
V_{OH}	High-level output voltage	$V_{ID} = 200 \text{ mV}$, $I_{OH} = -8 \text{ mA}$	3.5	4.5		V
V_{OL}	Low-level output voltage	$V_{ID} = -200 \text{ mV}$, $I_{OL} = 8 \text{ mA}$		0.3	0.5	V
I_I	Bus input current	$V_I = 12 \text{ V}$, Other inputs at 0 V, $V_{CC} = 5 \text{ V}$	SN65LBC179, SN75LBC179	0.7	1	mA
			SN65LBC179Q	0.7	1.2	mA
		$V_I = 12 \text{ V}$, Other inputs at 0 V, $V_{CC} = 0 \text{ V}$	SN65LBC179, SN75LBC179	0.8	1	mA
			SN65LBC179Q	0.8	1.2	mA
		$V_I = -7 \text{ V}$, Other inputs at 0 V, $V_{CC} = 5 \text{ V}$	SN65LBC179, SN75LBC179	-0.5	-0.8	mA
			SN65LBC179Q	-0.5	-1.0	mA
$V_I = -7 \text{ V}$, Other inputs at 0 V, $V_{CC} = 0 \text{ V}$	SN65LBC179, SN75LBC179	-0.5	-0.8	mA		
	SN65LBC179Q	-0.5	-1.0	mA		

switching characteristics, $V_{CC} = 5 \text{ V}$, $T_A = 25^\circ\text{C}$

PARAMETER		TEST CONDITIONS	MIN	TYP	MAX	UNIT
t_{PHL}	Propagation delay time, high- to low-level output	$V_{ID} = -1.5 \text{ V to } 1.5 \text{ V}$, See Figure 4	15		30	ns
t_{PLH}	Propagation delay time, low- to high-level output		15		30	ns
$t_{sk(p)}$	Pulse skew ($ t_{PHL} - t_{PLH} $)	See Figure 4		3	6	ns
t_t	Transition time			3	5	ns

PARAMETER MEASUREMENT INFORMATION

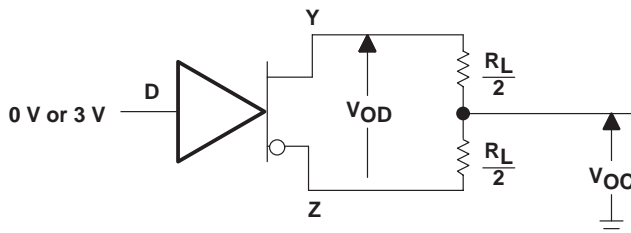

Figure 1. Differential and Common-Mode Output Voltage Test Circuit

SN75LBC179, SN65LBC179, SN65LBC179Q LOW-POWER DIFFERENTIAL LINE DRIVER AND RECEIVER PAIRS

SLLS173D – JANUARY 1994 – REVISED JUNE 2000

PARAMETER MEASUREMENT INFORMATION

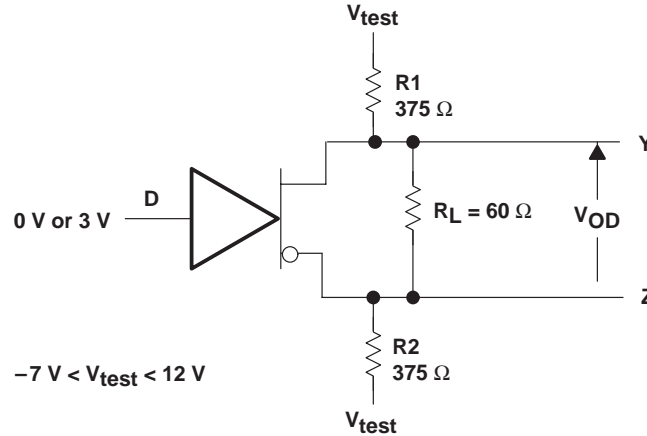
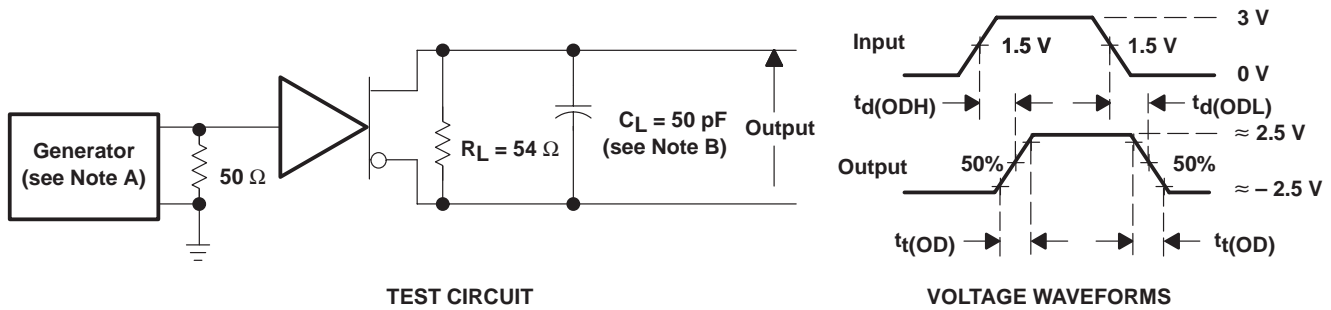
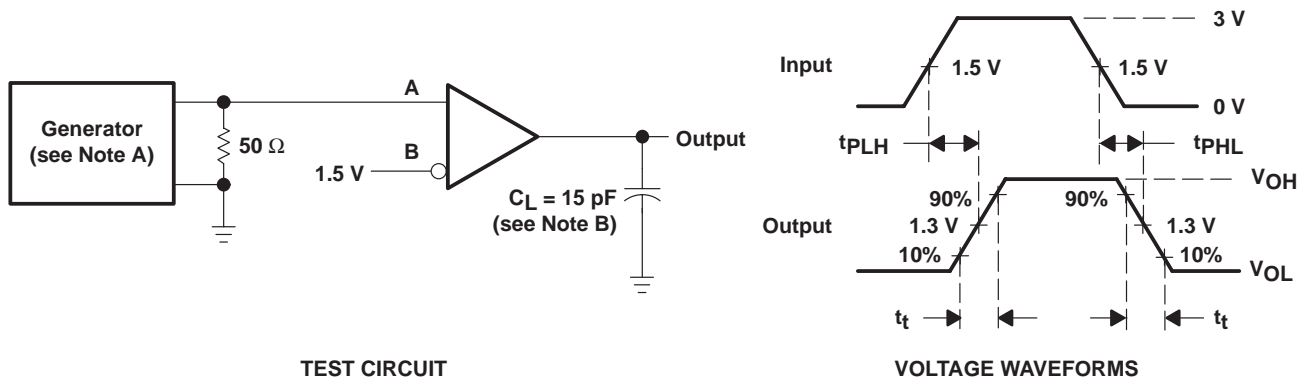

Figure 2. Differential Output Voltage Test Circuit



NOTES: A. The input pulse is supplied by a generator having the following characteristics: PRR \leq 1 MHz, 50% duty cycle, $t_r \leq$ 6 ns, $t_f \leq$ 6 ns, $Z_O = 50 \Omega$.
B. C_L includes probe and jig capacitance.

Figure 3. Driver Test Circuits and Differential Output Delay and Transition Time Voltage Waveforms



NOTES: A. The input pulse is supplied by a generator having the following characteristics: PRR \leq 1 MHz, 50% duty cycle, $t_r \leq$ 6 ns, $t_f \leq$ 6 ns, $Z_O = 50 \Omega$.
B. C_L includes probe and jig capacitance.

Figure 4. Receiver Test Circuit and Propagation Delay and Transition Time Voltage Waveforms

SN75LBC179, SN65LBC179, SN65LBC179Q LOW-POWER DIFFERENTIAL LINE DRIVER AND RECEIVER PAIRS

SLLS173D – JANUARY 1994 – REVISED JUNE 2000

TYPICAL CHARACTERISTICS

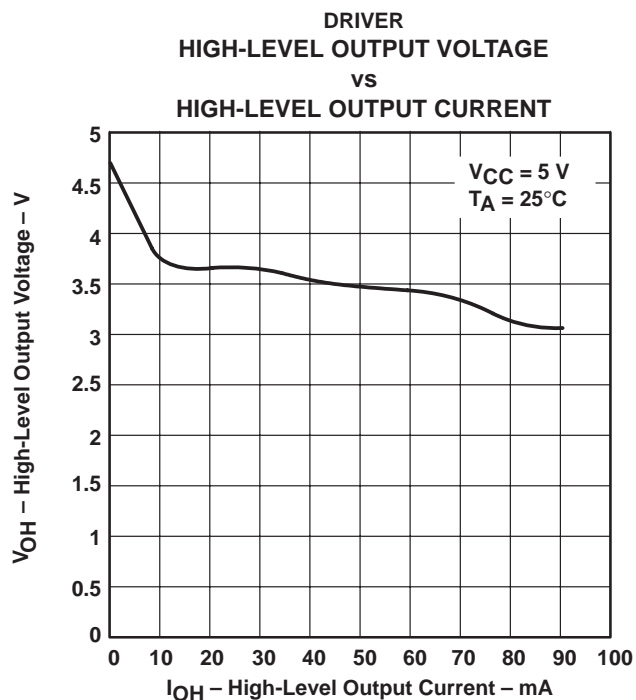

Figure 5

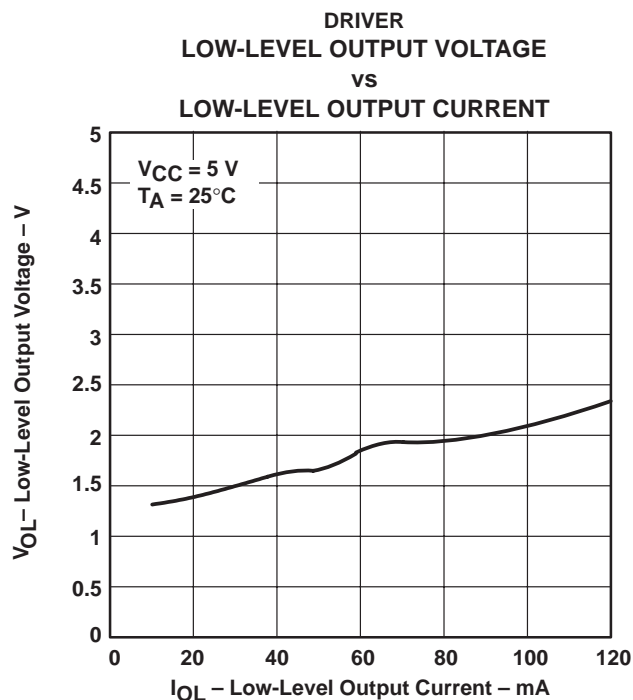

Figure 6

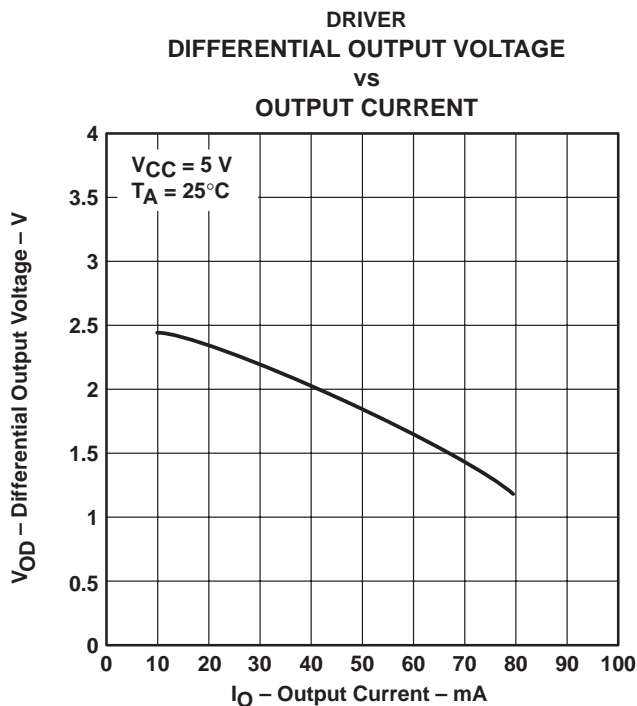

Figure 7

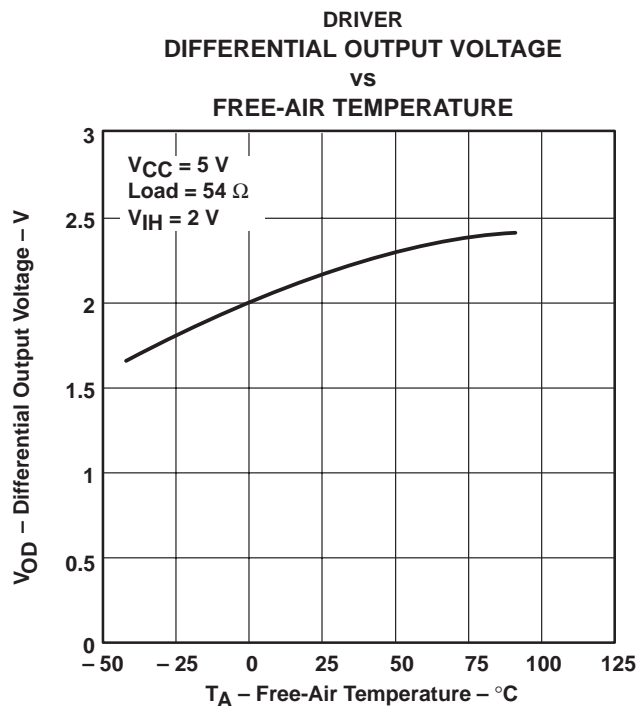

Figure 8



SN75LBC179, SN65LBC179, SN65LBC179Q LOW-POWER DIFFERENTIAL LINE DRIVER AND RECEIVER PAIRS

SLLS173D – JANUARY 1994 – REVISED JUNE 2000

TYPICAL CHARACTERISTICS

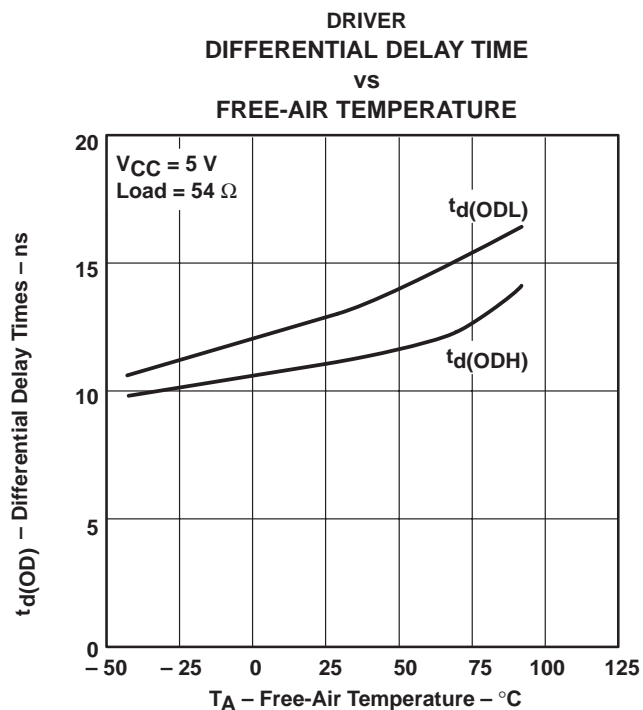

Figure 9

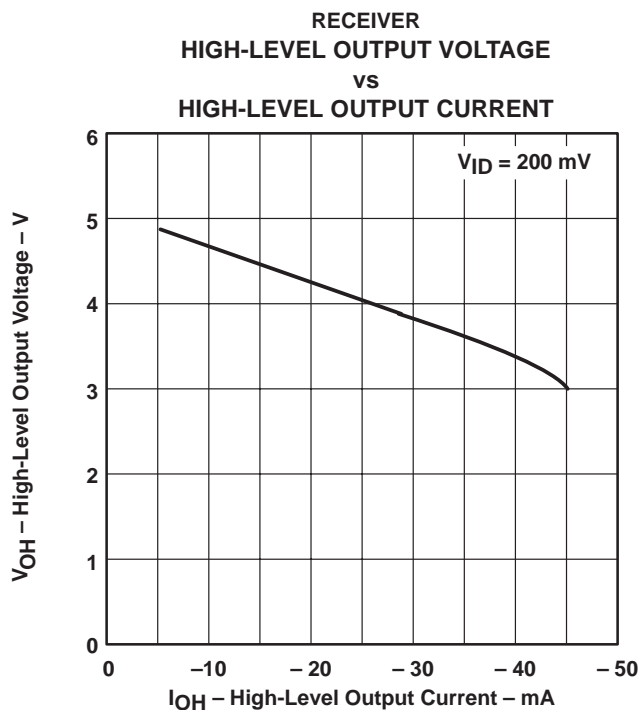

Figure 10

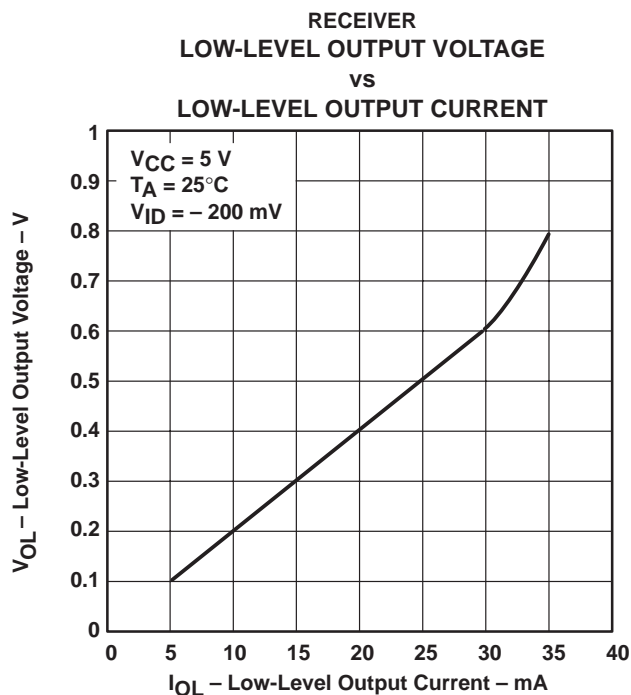

Figure 11

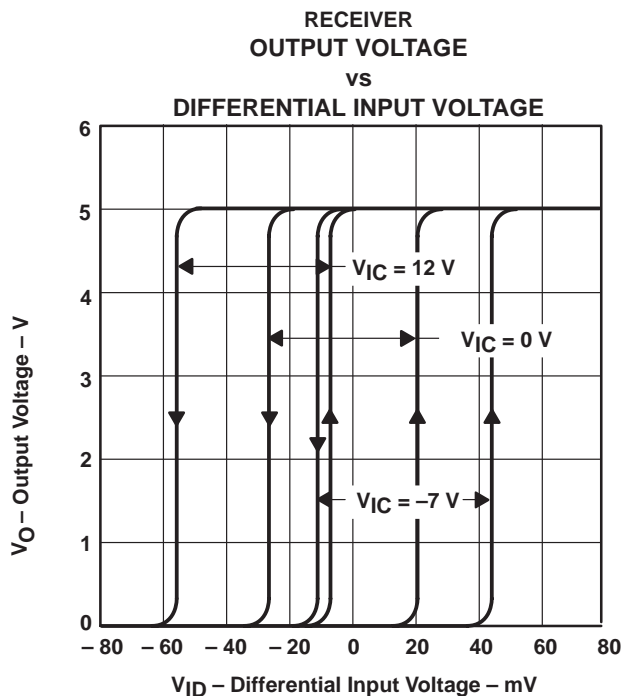

Figure 12



SN75LBC179, SN65LBC179, SN65LBC179Q LOW-POWER DIFFERENTIAL LINE DRIVER AND RECEIVER PAIRS

SLLS173D – JANUARY 1994 – REVISED JUNE 2000

TYPICAL CHARACTERISTICS

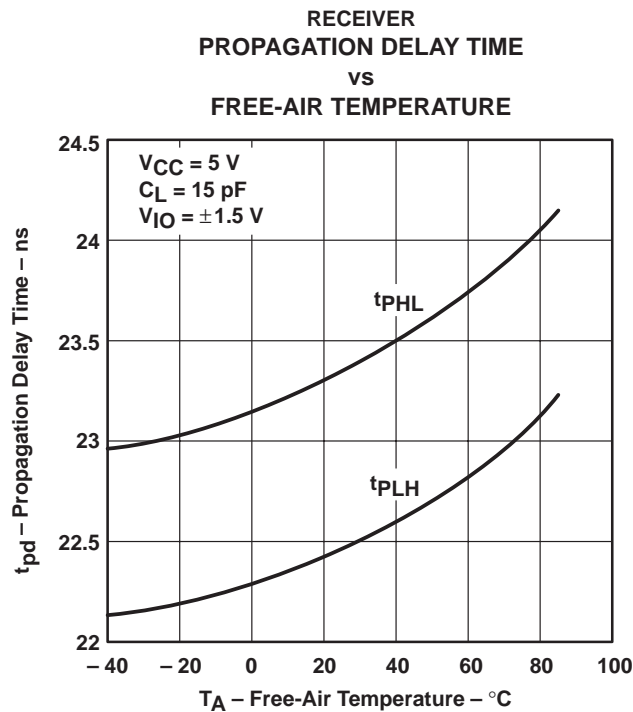
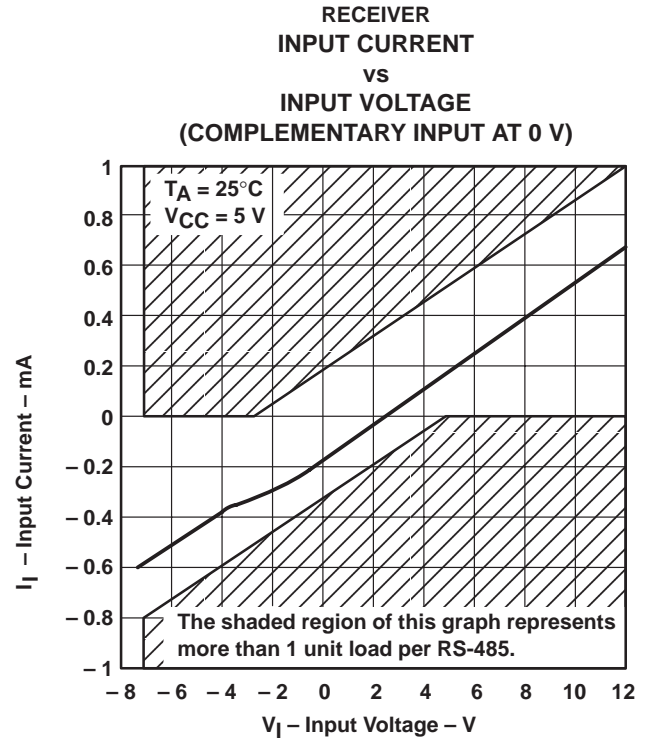
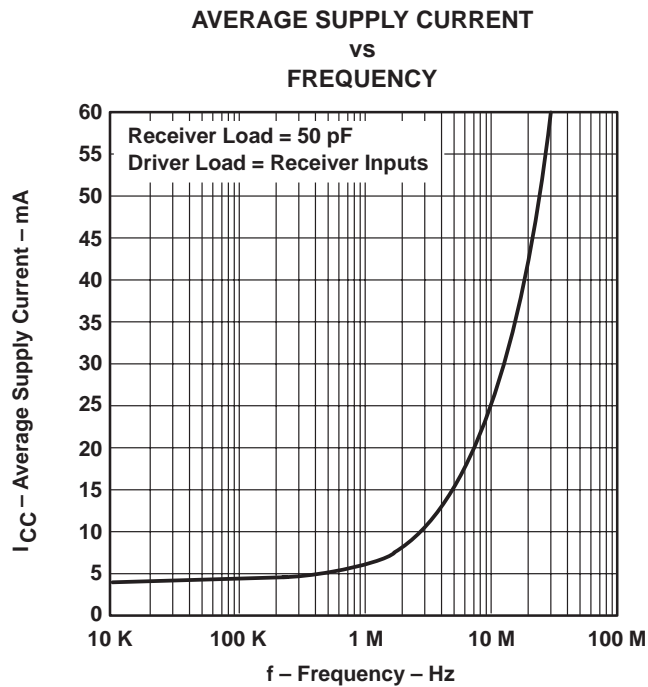

SN75LBC179, SN65LBC179, SN65LBC179Q LOW-POWER DIFFERENTIAL LINE DRIVER AND RECEIVER PAIRS

SLLS173D – JANUARY 1994 – REVISED JUNE 2000

MECHANICAL INFORMATION

D (R-PDSO-G**)

PLASTIC SMALL-OUTLINE PACKAGE

14 PIN SHOWN

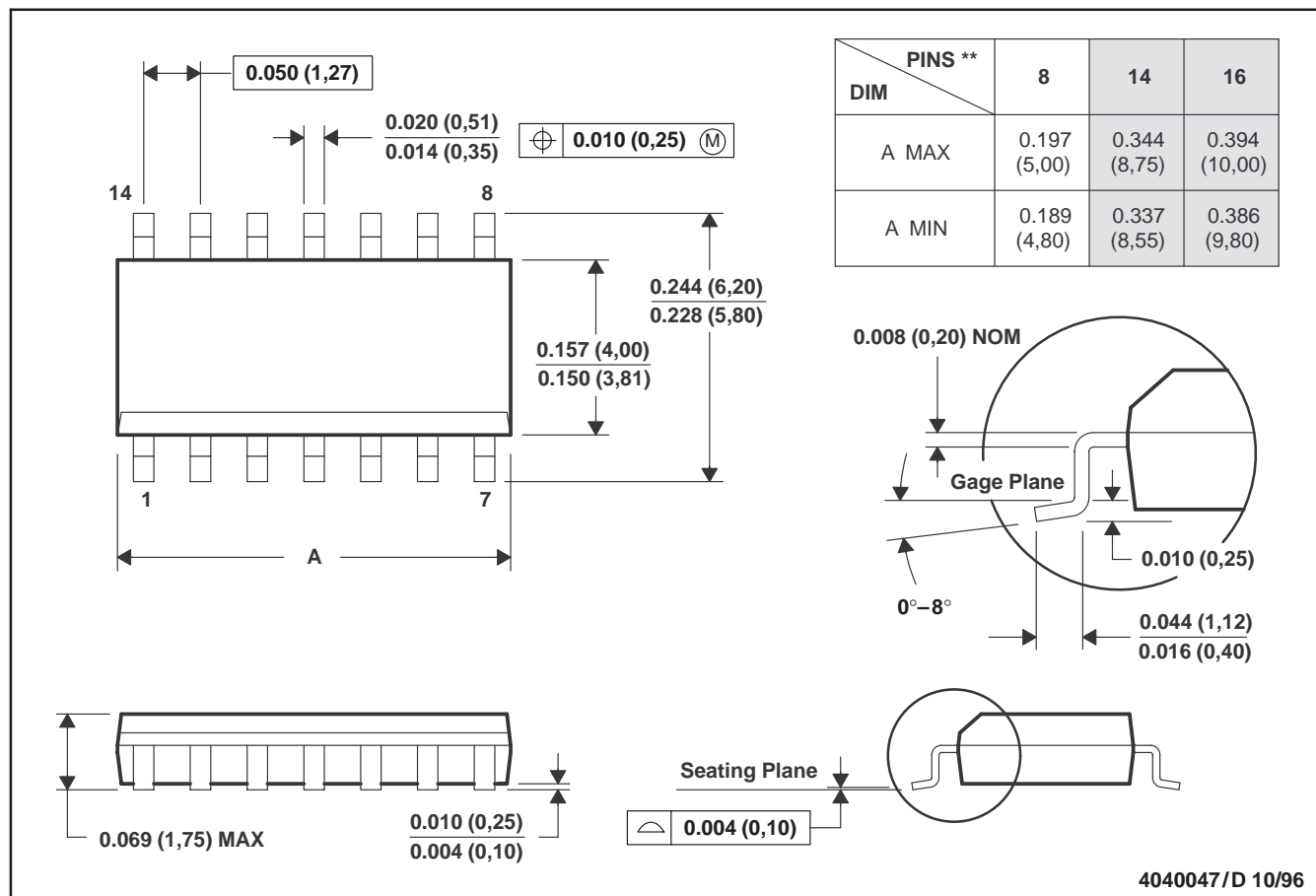

- NOTES:
- A. All linear dimensions are in inches (millimeters).
 - B. This drawing is subject to change without notice.
 - C. Body dimensions do not include mold flash or protrusion, not to exceed 0.006 (0,15).
 - D. Falls within JEDEC MS-012

SN75LBC179, SN65LBC179, SN65LBC179Q LOW-POWER DIFFERENTIAL LINE DRIVER AND RECEIVER PAIRS

SLLS173D – JANUARY 1994 – REVISED JUNE 2000

MECHANICAL INFORMATION

P (R-PDIP-T8)

PLASTIC DUAL-IN-LINE

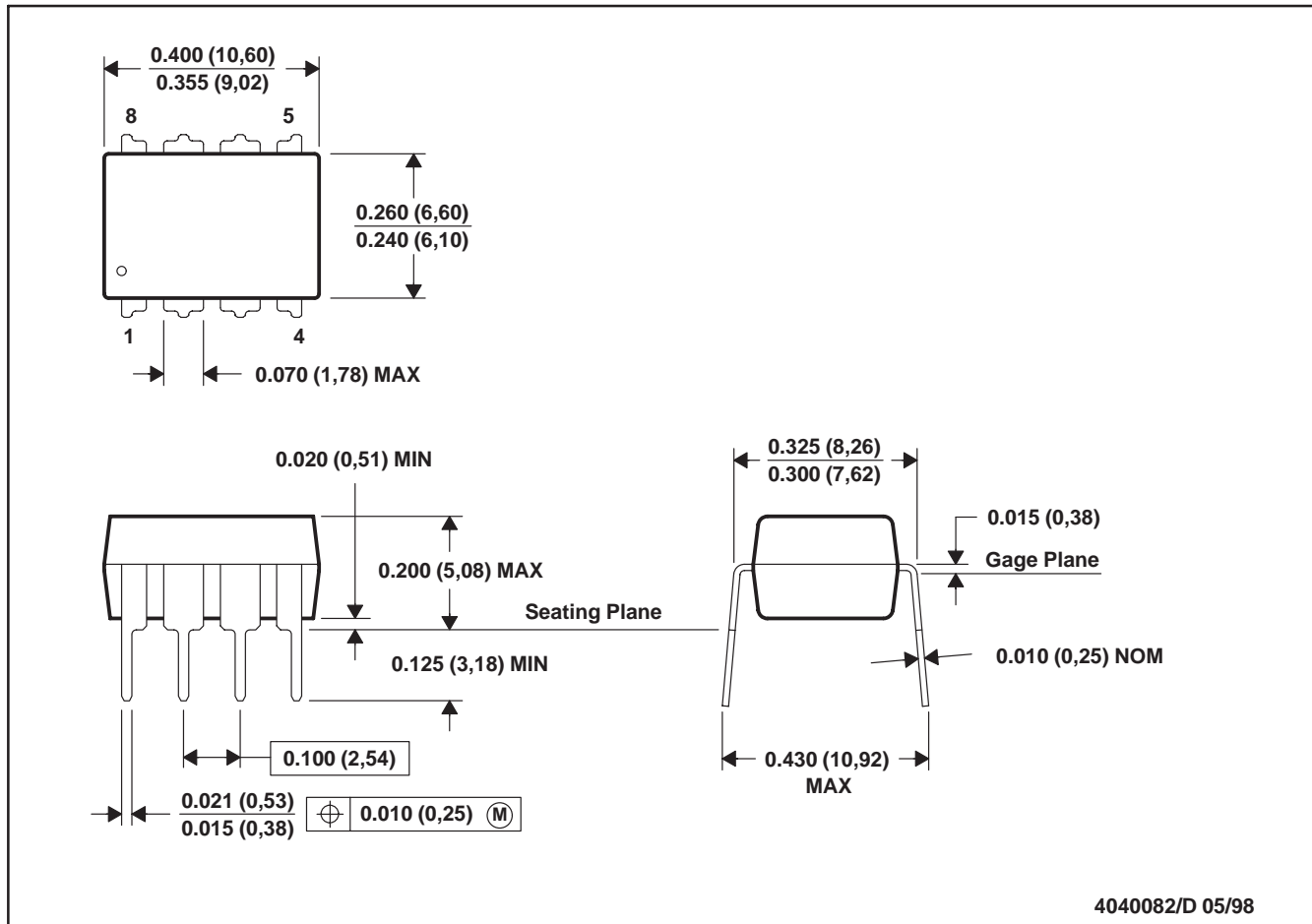

- NOTES: A. All linear dimensions are in inches (millimeters).
 B. This drawing is subject to change without notice.
 C. Falls within JEDEC MS-001

For the latest package information, go to http://www.ti.com/sc/docs/package/pkg_info.htm



POST OFFICE BOX 655303 • DALLAS, TEXAS 75265

PACKAGING INFORMATION

Orderable Device	Status ⁽¹⁾	Package Type	Package Drawing	Pins	Package Qty	Eco Plan ⁽²⁾	Lead/Ball Finish	MSL Peak Temp ⁽³⁾
SN65LBC179D	ACTIVE	SOIC	D	8	75	Pb-Free (RoHS)	CU NIPDAU	Level-2-260C-1YEAR/ Level-1-220C-UNLIM
SN65LBC179DR	ACTIVE	SOIC	D	8	2500	Pb-Free (RoHS)	CU NIPDAU	Level-2-260C-1YEAR/ Level-1-220C-UNLIM
SN65LBC179P	ACTIVE	PDIP	P	8	50	Pb-Free (RoHS)	CU NIPDAU	Level-NC-NC-NC
SN65LBC179QD	ACTIVE	SOIC	D	8	75	Pb-Free (RoHS)	CU NIPDAU	Level-2-250C-1 YEAR/ Level-1-235C-UNLIM
SN65LBC179QDR	ACTIVE	SOIC	D	8	2500	Pb-Free (RoHS)	CU NIPDAU	Level-2-250C-1 YEAR/ Level-1-235C-UNLIM
SN75LBC179D	ACTIVE	SOIC	D	8	75	Pb-Free (RoHS)	CU NIPDAU	Level-2-260C-1YEAR/ Level-1-220C-UNLIM
SN75LBC179DR	ACTIVE	SOIC	D	8	2500	Pb-Free (RoHS)	CU NIPDAU	Level-2-260C-1YEAR/ Level-1-220C-UNLIM
SN75LBC179P	ACTIVE	PDIP	P	8	50	Pb-Free (RoHS)	CU NIPDAU	Level-NC-NC-NC

⁽¹⁾ The marketing status values are defined as follows:

ACTIVE: Product device recommended for new designs.

LIFEBUY: TI has announced that the device will be discontinued, and a lifetime-buy period is in effect.

NRND: Not recommended for new designs. Device is in production to support existing customers, but TI does not recommend using this part in a new design.

PREVIEW: Device has been announced but is not in production. Samples may or may not be available.

OBSOLETE: TI has discontinued the production of the device.

⁽²⁾ Eco Plan - May not be currently available - please check <http://www.ti.com/productcontent> for the latest availability information and additional product content details.

None: Not yet available Lead (Pb-Free).

Pb-Free (RoHS): TI's terms "Lead-Free" or "Pb-Free" mean semiconductor products that are compatible with the current RoHS requirements for all 6 substances, including the requirement that lead not exceed 0.1% by weight in homogeneous materials. Where designed to be soldered at high temperatures, TI Pb-Free products are suitable for use in specified lead-free processes.

Green (RoHS & no Sb/Br): TI defines "Green" to mean "Pb-Free" and in addition, uses package materials that do not contain halogens, including bromine (Br) or antimony (Sb) above 0.1% of total product weight.

⁽³⁾ MSL, Peak Temp. -- The Moisture Sensitivity Level rating according to the JEDEC industry standard classifications, and peak solder temperature.

Important Information and Disclaimer: The information provided on this page represents TI's knowledge and belief as of the date that it is provided. TI bases its knowledge and belief on information provided by third parties, and makes no representation or warranty as to the accuracy of such information. Efforts are underway to better integrate information from third parties. TI has taken and continues to take reasonable steps to provide representative and accurate information but may not have conducted destructive testing or chemical analysis on incoming materials and chemicals. TI and TI suppliers consider certain information to be proprietary, and thus CAS numbers and other limited information may not be available for release.

In no event shall TI's liability arising out of such information exceed the total purchase price of the TI part(s) at issue in this document sold by TI to Customer on an annual basis.

IMPORTANT NOTICE

Texas Instruments Incorporated and its subsidiaries (TI) reserve the right to make corrections, modifications, enhancements, improvements, and other changes to its products and services at any time and to discontinue any product or service without notice. Customers should obtain the latest relevant information before placing orders and should verify that such information is current and complete. All products are sold subject to TI's terms and conditions of sale supplied at the time of order acknowledgment.

TI warrants performance of its hardware products to the specifications applicable at the time of sale in accordance with TI's standard warranty. Testing and other quality control techniques are used to the extent TI deems necessary to support this warranty. Except where mandated by government requirements, testing of all parameters of each product is not necessarily performed.

TI assumes no liability for applications assistance or customer product design. Customers are responsible for their products and applications using TI components. To minimize the risks associated with customer products and applications, customers should provide adequate design and operating safeguards.

TI does not warrant or represent that any license, either express or implied, is granted under any TI patent right, copyright, mask work right, or other TI intellectual property right relating to any combination, machine, or process in which TI products or services are used. Information published by TI regarding third-party products or services does not constitute a license from TI to use such products or services or a warranty or endorsement thereof. Use of such information may require a license from a third party under the patents or other intellectual property of the third party, or a license from TI under the patents or other intellectual property of TI.

Reproduction of information in TI data books or data sheets is permissible only if reproduction is without alteration and is accompanied by all associated warranties, conditions, limitations, and notices. Reproduction of this information with alteration is an unfair and deceptive business practice. TI is not responsible or liable for such altered documentation.

Resale of TI products or services with statements different from or beyond the parameters stated by TI for that product or service voids all express and any implied warranties for the associated TI product or service and is an unfair and deceptive business practice. TI is not responsible or liable for any such statements.

Following are URLs where you can obtain information on other Texas Instruments products and application solutions:

Products		Applications	
Amplifiers	amplifier.ti.com	Audio	www.ti.com/audio
Data Converters	dataconverter.ti.com	Automotive	www.ti.com/automotive
DSP	dsp.ti.com	Broadband	www.ti.com/broadband
Interface	interface.ti.com	Digital Control	www.ti.com/digitalcontrol
Logic	logic.ti.com	Military	www.ti.com/military
Power Mgmt	power.ti.com	Optical Networking	www.ti.com/opticalnetwork
Microcontrollers	microcontroller.ti.com	Security	www.ti.com/security
		Telephony	www.ti.com/telephony
		Video & Imaging	www.ti.com/video
		Wireless	www.ti.com/wireless

Mailing Address: Texas Instruments
Post Office Box 655303 Dallas, Texas 75265