

# SN65LVDM179, SN65LVDM180, SN65LVDM050, SN65LVDM051 HIGH-SPEED DIFFERENTIAL LINE DRIVERS AND RECEIVERS

SLLS324F – DECEMBER 1998 – REVISED MARCH 2003

- **Low-Voltage Differential 50-Ω Line Drivers and Receivers**
- **Typical Signaling Rates of 500 Mbps**
- **Bus-Terminal ESD Exceeds 12 kV**
- **Operates From a Single 3.3-V Supply**
- **Low-Voltage Differential Signaling With Typical Output Voltages of 340 mV With a 50-Ω Load**
- **Valid Output With as Little as 50-mV Input Voltage Difference**
- **Propagation Delay Times**
  - Driver: 1.7 ns Typical
  - Receiver: 3.7 ns Typical
- **Power Dissipation at 200 MHz**
  - Driver: 50 mW Typical
  - Receiver: 60 mW Typical
- **LVTTL Input Levels Are 5-V Tolerant**
- **Driver Is High Impedance When Disabled or With  $V_{CC} < 1.5$  V**
- **Receiver Has Open-Circuit Failsafe**

## description

The SN65LVDM179, SN65LVDM180, SN65LVDM050, and SN65LVDM051 are differential line drivers and receivers that use low-voltage differential signaling (LVDS) to achieve high signaling rates. These circuits are similar to TIA/EIA-644 standard compliant devices (SN65LVDS) counterparts, except that the output current of the drivers is doubled. This modification provides a minimum differential output voltage magnitude of 247 mV across a 50-Ω load simulating two transmission lines in parallel. This allows having data buses with more than one driver or with two line termination resistors. The receivers detect a voltage difference of 50 mV with up to 1 V of ground potential difference between a transmitter and receiver.

The intended application of these devices and signaling techniques is point-to-point half duplex, baseband data transmission over a controlled impedance media of approximately 100 Ω characteristic impedance. The transmission media may be printed-circuit board traces, backplanes, or cables.

**SN65LVDM179D** (Marked as DM179 or LVM179)  
**SN65LVDM179DGK** (Marked as M79)  
(TOP VIEW)

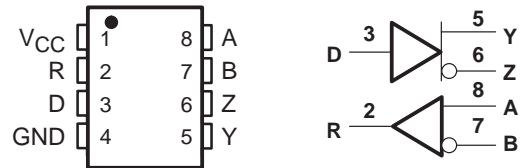

**SN65LVDM180D** (Marked as LVDM180)  
**SN65LVDM180PW** (Marked as LVDM180)  
(TOP VIEW)

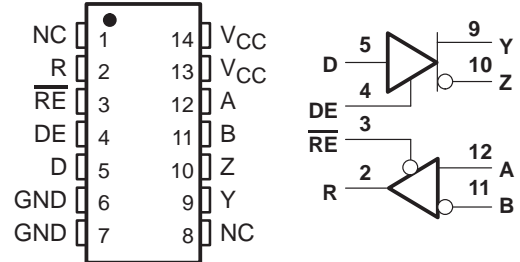

**SN65LVDM050D** (Marked as LVDM050)  
**SN65LVDM050PW** (Marked as LVDM050)  
(TOP VIEW)

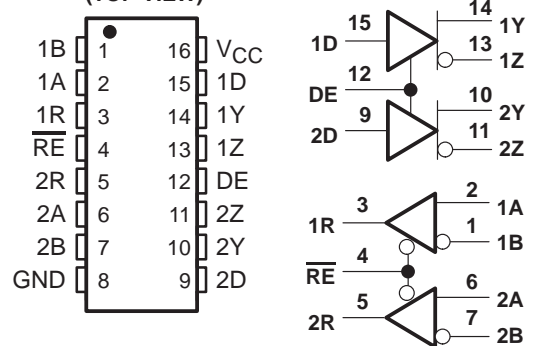

**SN65LVDM051D** (Marked as LVDM051)  
**SN65LVDM051PW** (Marked as LVDM051)  
(TOP VIEW)

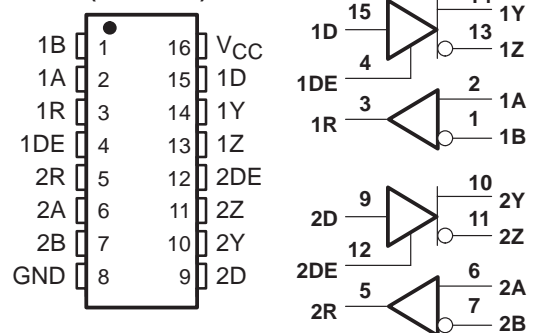

Please be aware that an important notice concerning availability, standard warranty, and use in critical applications of Texas Instruments semiconductor products and disclaimers thereto appears at the end of this data sheet.

PRODUCTION DATA information is current as of publication date. Products conform to specifications per the terms of Texas Instruments standard warranty. Production processing does not necessarily include testing of all parameters.

**TEXAS  
INSTRUMENTS**

POST OFFICE BOX 655303 • DALLAS, TEXAS 75265

Copyright © 2001 – 2003 Texas Instruments Incorporated

# SN65LVDM179, SN65LVDM180, SN65LVDM050, SN65LVDM051 HIGH-SPEED DIFFERENTIAL LINE DRIVERS AND RECEIVERS

SLLS324F – DECEMBER 1998 – REVISED MARCH 2003

## description (continued)

The ultimate rate and distance of data transfer is dependent upon the attenuation characteristics of the media, the noise coupling to the environment, and other application-specific characteristics.

The SN65LVDM179, SN65LVDM180, SN65LVDM050, and SN65LVDM051 are characterized for operation from  $-40^{\circ}\text{C}$  to  $85^{\circ}\text{C}$ .

### AVAILABLE OPTIONS

| T <sub>A</sub> | PACKAGE           |                     |                    |
|----------------|-------------------|---------------------|--------------------|
|                | SMALL OUTLINE (D) | SMALL OUTLINE (DGK) | SMALL OUTLINE (PW) |
| -40°C to 85°C  | SN65LVDM050D      | —                   | SN65LVDM050PW      |
|                | SN65LVDM051D      | —                   | SN65LVDM051PW      |
|                | SN65LVDM179D      | SN65LVDM179DGK      | —                  |
|                | SN65LVDM180D      | —                   | SN65LVDM180PW      |

### Function Tables

#### SN65LVDM179 RECEIVER

| INPUTS                                    | OUTPUT |
|---|--------|
| $V_{ID} = V_A - V_B$                      | R      |
| $V_{ID} \geq 50 \text{ mV}$               | H      |
| $-50 \text{ mV} < V_{ID} < 50 \text{ mV}$ | ?      |
| $V_{ID} \leq -50 \text{ mV}$              | L      |
| Open                                      | H      |

H = high level, L = low level, ? = indeterminate

#### SN65LVDM179 DRIVER

| INPUT | OUTPUTS |   |
|-------|---------|---|
| D     | Y       | Z |
| L     | L       | H |
| H     | H       | L |
| Open  | L       | H |

H = high level, L = low level

#### SN65LVDM180, SN65LVDM050, and SN65LVDM051 RECEIVER

| INPUTS                                    |                        | OUTPUT |
|---|------------------------|--------|
| $V_{ID} = V_A - V_B$                      | $\overline{\text{RE}}$ | R      |
| $V_{ID} \geq 50 \text{ mV}$               | L                      | H      |
| $-50 \text{ mV} < V_{ID} < 50 \text{ mV}$ | L                      | ?      |
| $V_{ID} \leq -50 \text{ mV}$              | L                      | L      |
| Open                                      | L                      | H      |
| X   | H                      | Z      |

H = high level, L = low level, Z = high impedance, X = don't care

### Function Tables (Continued)

#### SN65LVDM180, SN65LVDM050, and SN65LVDM051 DRIVER



# SN65LVDM179, SN65LVDM180, SN65LVDM050, SN65LVDM051 HIGH-SPEED DIFFERENTIAL LINE DRIVERS AND RECEIVERS

SLLS324F – DECEMBER 1998 – REVISED MARCH 2003

| INPUTS |    | OUTPUTS |   |
|--------|----|---------|---|
| D      | DE | Y       | Z |
| L      | H  | L       | H |
| H      | H  | H       | L |
| Open   | H  | L       | H |
| X      | L  | Z       | Z |

H = high level, L = low level, Z = high impedance,  
X = don't care

## equivalent input and output schematic diagrams

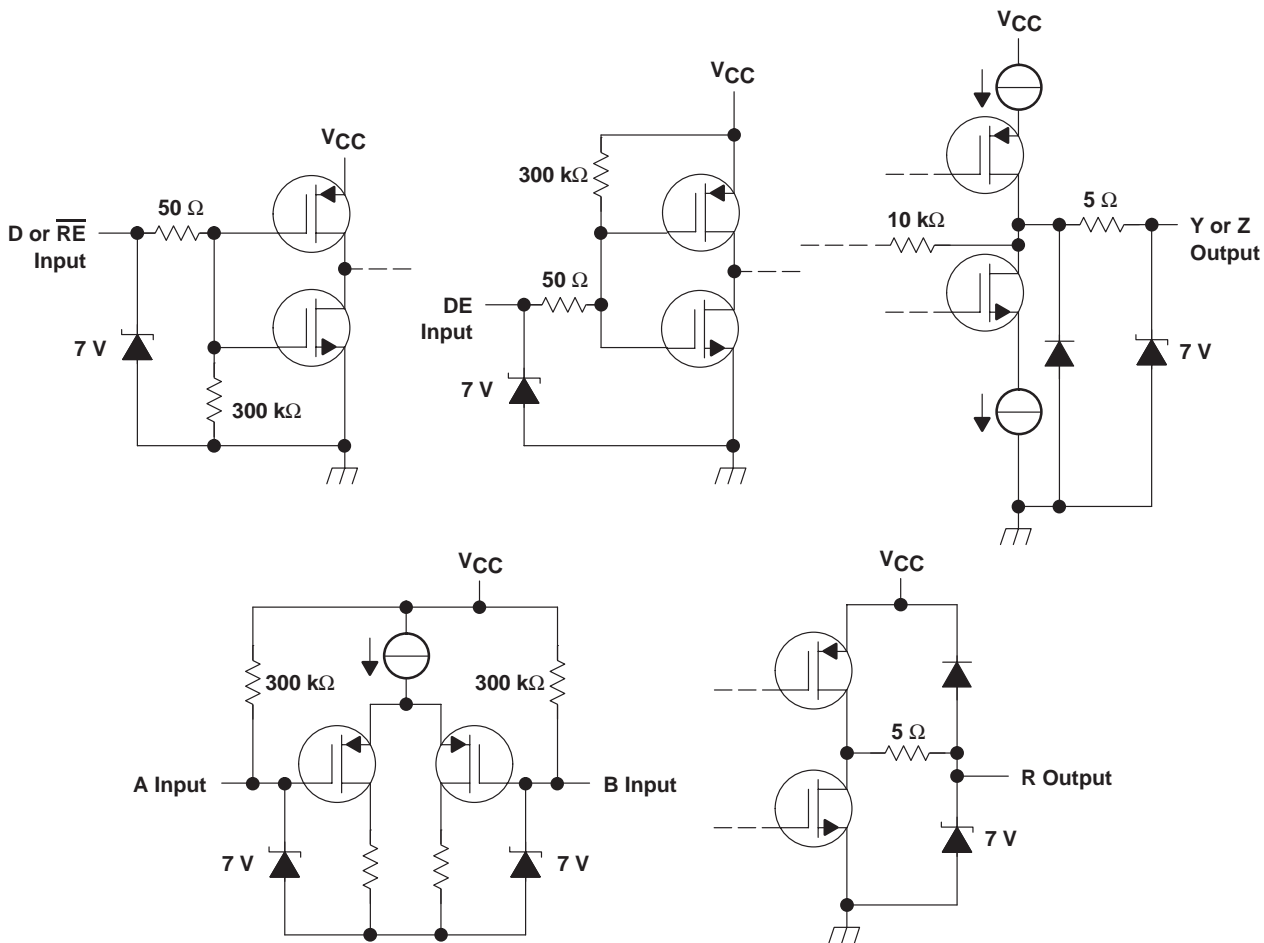

# SN65LVDM179, SN65LVDM180, SN65LVDM050, SN65LVDM051 HIGH-SPEED DIFFERENTIAL LINE DRIVERS AND RECEIVERS

SLLS324F – DECEMBER 1998 – REVISED MARCH 2003

## absolute maximum ratings over operating free-air temperature (unless otherwise noted)†

|   |                              |
|---|------------------------------|
| Supply voltage range, $V_{CC}$ (see Note 1)               | –0.5 V to 4 V                |
| Voltage range (D, R, DE, $\overline{RE}$ )                | –0.5 V to 6 V                |
| Voltage range (Y, Z, A, and B)                            | –0.5 V to 4 V                |
| Electrostatic discharge: Y, Z, A, B, and GND (see Note 2) | Class 3, A:12 kV, B:600 V    |
| All   | Class 3, A:7 kV, B:500 V     |
| Continuous power dissipation                              | see dissipation rating table |
| Storage temperature range                                 | –65°C to 150°C               |

† Stresses beyond those listed under “absolute maximum ratings” may cause permanent damage to the device. These are stress ratings only, and functional operation of the device at these or any other conditions beyond those indicated under “recommended operating conditions” is not implied. Exposure to absolute-maximum-rated conditions for extended periods may affect device reliability.

- NOTES: 1. All voltage values, except differential I/O bus voltages, are with respect to network ground terminal.  
2. Tested in accordance with MIL-STD-883C Method 3015.7.

DISSIPATION RATING TABLE

| PACKAGE | $T_A \leq 25^\circ\text{C}$<br>POWER RATING | DERATING FACTOR<br>ABOVE $T_A = 25^\circ\text{C}$ ‡ | $T_A = 85^\circ\text{C}$<br>POWER RATING |
|---------|---|---|--|
| D(8)    | 635 mW                                      | 5.1 mW/°C   | 330 mW                                   |
| D(14)   | 987 mW                                      | 7.9 mW/°C   | 513 mW                                   |
| D(16)   | 1110 mW                                     | 8.9 mW/°C   | 577 mW                                   |
| DGK     | 424 mW                                      | 3.4 mW/°C   | 220 mW                                   |
| PW (14) | 736 mW                                      | 5.9 mW/°C   | 383 mW                                   |
| PW (16) | 839 mW                                      | 6.7 mW/°C   | 437 mW                                   |

‡ This is the inverse of the junction-to-ambient thermal resistance when board-mounted and with no air flow.

## recommended operating conditions

|   | MIN                  | NOM | MAX                        | UNIT |
|---|----------------------|-----|----------------------------|------|
| Supply voltage, $V_{CC}$                            | 3                    | 3.3 | 3.6                        | V    |
| Driver output voltage, $V_O$                        | 0                    |     | 2.4                        | V    |
| High-level input voltage, $V_{IH}$                  | 2                    |     |                            | V    |
| Low-level input voltage, $V_{IL}$                   |                      |     | 0.8                        | V    |
| Magnitude of differential input voltage, $ V_{ID} $ | 0.1                  |     | 0.6                        | V    |
| Common-mode input voltage, $V_{IC}$ (see Figure 6)  | $\frac{ V_{ID} }{2}$ |     | $2.4 - \frac{ V_{ID} }{2}$ | V    |
|   |                      |     | $V_{CC} - 0.8$             |      |
| Operating free-air temperature, $T_A$               | –40                  |     | 85                         | °C   |



# SN65LVDM179, SN65LVDM180, SN65LVDM050, SN65LVDM051 HIGH-SPEED DIFFERENTIAL LINE DRIVERS AND RECEIVERS

SLLS324F – DECEMBER 1998 – REVISED MARCH 2003

device electrical characteristics over recommended operating conditions (unless otherwise noted)

| PARAMETER                  |                | TEST CONDITIONS | MIN  | TYP†     | MAX | UNIT |    |    |
|----------------------------|----------------|-----------------|--|----------|-----|------|----|----|
| I <sub>CC</sub>            | Supply current | SN65LVDM179     | No receiver load, driver R <sub>L</sub> = 50 Ω                                 |          | 10  | 15   | mA |    |
|                            |                | SN65LVDM180     | Driver and receiver enabled, no receiver load, driver R <sub>L</sub> = 50 Ω    |          | 10  | 15   |    |    |
|                            |                |                 | Driver enabled, receiver disabled, R <sub>L</sub> = 50 Ω                       |          | 9   | 13   |    |    |
|                            |                |                 | Driver disabled, receiver enabled, no load                                     |          | 1.7 | 5    |    |    |
|                            |                |                 |  | Disabled |     | 0.5  | 2  | mA |
|                            |                | SN65LVDM050     | Drivers and receivers enabled, no receiver loads, driver R <sub>L</sub> = 50 Ω |          | 19  | 27   |    |    |
|                            |                |                 | Drivers enabled, receivers disabled, R <sub>L</sub> = 50 Ω                     |          | 16  | 24   |    |    |
|                            |                |                 | Drivers disabled, receivers enabled, no loads                                  |          | 4   | 6    |    |    |
|                            |                |                 |  | Disabled |     | 0.5  | 1  | mA |
|                            |                | SN65LVDM051     | Drivers enabled, no receiver loads, driver R <sub>L</sub> = 50 Ω               |          | 19  | 27   |    |    |
| Drivers disabled, no loads |                |                 | 4  | 6        |     |      |    |    |

† All typical values are at 25°C and with a 3.3 V supply.

driver electrical characteristics over recommended operating conditions (unless otherwise noted)

| PARAMETER            |  | TEST CONDITIONS   | MIN                     | TYP | MAX   | UNIT |
|----------------------|--|---|-------------------------|-----|-------|------|
| V <sub>OD</sub>      | Differential output voltage magnitude                                  | R <sub>L</sub> = 50 Ω,<br>See Figure 1 and Figure 2                                       | 247                     | 340 | 454   | mV   |
| Δ V <sub>OD</sub>    | Change in differential output voltage magnitude between logic states   |   | -50‡                    |     | 50    |      |
| V <sub>OC(SS)</sub>  | Steady-state common-mode output voltage                                | See Figure 3  | 1.125                   | 1.2 | 1.375 | V    |
| ΔV <sub>OC(SS)</sub> | Change in steady-state common-mode output voltage between logic states |   | -50                     |     | 50    | mV   |
| V <sub>OC(PP)</sub>  | Peak-to-peak common-mode output voltage                                |   |                         | 50  | 150   | mV   |
| I <sub>IH</sub>      | High-level input current   | DE  | V <sub>IH</sub> = 5 V   | -20 | -0.5  | μA   |
|                      |  | D   |                         |     | 2     |      |
| I <sub>IL</sub>      | Low-level input current  | DE  | V <sub>IL</sub> = 0.8 V | -10 | -0.5  | μA   |
|                      |  | D   |                         |     | 2     |      |
| I <sub>OS</sub>      | Short-circuit output current   | V <sub>OY</sub> or V <sub>OZ</sub> = 0 V  |                         | 7   | 10    | mA   |
|                      |  | V <sub>OD</sub> = 0 V   |                         | 7   | 10    |      |
| I <sub>OZ</sub>      | High-impedance output current  | V <sub>O</sub> = 0 V or 2.4 V, other output at 1.2 V, DE AT 0.8 V.                        |                         | -47 | 47    | μA   |
| I <sub>O(OFF)</sub>  | Power-off output current   | V <sub>CC</sub> = 0 V, V <sub>O</sub> = 0 V or 2.4 V, other output at 1.2 V, DE AT 0.8 V. |                         | -47 | 47    | μA   |
| C <sub>IN</sub>      | Input capacitance  |   |                         | 3   |       | pF   |

‡ The algebraic convention in which the least positive (most negative) value is designated minimum is used in this datasheet.



# SN65LVDM179, SN65LVDM180, SN65LVDM050, SN65LVDM051 HIGH-SPEED DIFFERENTIAL LINE DRIVERS AND RECEIVERS

SLLS324F – DECEMBER 1998 – REVISED MARCH 2003

## receiver electrical characteristics over recommended operating conditions (unless otherwise noted)

| PARAMETER           |   | TEST CONDITIONS           | MIN | TYP† | MAX  | UNIT |
|---------------------|---|---------------------------|-----|------|------|------|
| V <sub>IT+</sub>    | Positive-going differential input voltage threshold | See Figure 5 and Table 1  |     |      | 50   | mV   |
| V <sub>IT-</sub>    | Negative-going differential input voltage threshold |                           |     |      | -50  |      |
| V <sub>OH</sub>     | High-level output voltage                           | I <sub>OH</sub> = -8 mA   | 2.4 |      |      | V    |
| V <sub>OL</sub>     | Low-level output voltage                            | I <sub>OL</sub> = 8 mA    |     |      | 0.4  | V    |
| I <sub>I</sub>      | Input current (A or B inputs)                       | V <sub>I</sub> = 0        | -20 | -11  |      | μA   |
|                     |   | V <sub>I</sub> = 2.4 V    |     | -3   | -1.2 |      |
| I <sub>I(OFF)</sub> | Power-off input current (A or B inputs)             | V <sub>CC</sub> = 0       | -20 |      | 20   | μA   |
| I <sub>IH</sub>     | High-level input current (enables)                  | V <sub>IH</sub> = 5 V     |     |      | 10   | μA   |
| I <sub>IL</sub>     | Low-level input current (enables)                   | V <sub>IL</sub> = 0.8 V   |     |      | 10   | μA   |
| I <sub>OZ</sub>     | High-impedance output current                       | V <sub>O</sub> = 0 or 5 V | -10 |      | 10   | μA   |
| C <sub>I</sub>      | Input capacitance                                   |                           |     | 5    |      | pF   |

† All typical values are at 25°C and with a 3.3-V supply.

## driver switching characteristics over recommended operating conditions (unless otherwise noted)

| PARAMETER           |   | TEST CONDITIONS  | MIN | TYP† | MAX | UNIT |
|---------------------|---|--|-----|------|-----|------|
| t <sub>PLH</sub>    | Propagation delay time, low-to-high-level output            | R <sub>L</sub> = 50Ω,<br>C <sub>L</sub> = 10 pF,<br>See Figure 6 |     | 1.7  | 2.7 | ns   |
| t <sub>PHL</sub>    | Propagation delay time, high-to-low-level output            |  |     | 1.7  | 2.7 | ns   |
| t <sub>r</sub>      | Differential output signal rise time                        |  |     | 0.6  | 1   | ns   |
| t <sub>f</sub>      | Differential output signal fall time                        |  |     | 0.6  | 1   | ns   |
| t <sub>sk(p)</sub>  | Pulse skew ( t <sub>pHL</sub> - t <sub>pLH</sub>  )         |  |     | 250  |     | ps   |
| t <sub>sk(o)</sub>  | Channel-to-channel output skew‡                             |  |     | 100  |     | ps   |
| t <sub>sk(pp)</sub> | Part-to-part skew§  |  |     |      | 1   | ns   |
| t <sub>pZH</sub>    | Propagation delay time, high-impedance-to-high-level output | See Figure 7   |     | 6    | 10  | ns   |
| t <sub>pZL</sub>    | Propagation delay time, high-impedance-to-low-level output  |  |     | 6    | 10  | ns   |
| t <sub>PHZ</sub>    | Propagation delay time, high-level-to-high-impedance output |  |     | 4    | 10  | ns   |
| t <sub>PLZ</sub>    | Propagation delay time, low-level-to-high-impedance output  |  |     | 5    | 10  | ns   |

† All typical values are at 25°C and with a 3.3-V supply.

‡ t<sub>sk(o)</sub> is the maximum delay time difference between drivers on the same device.

§ t<sub>sk(pp)</sub> is the magnitude of the difference in propagation delay times between any specified terminals of two devices when both devices operate with the same supply voltages, at the same temperature, and have identical packages and test circuits.

# SN65LVDM179, SN65LVDM180, SN65LVDM050, SN65LVDM051 HIGH-SPEED DIFFERENTIAL LINE DRIVERS AND RECEIVERS

SLLS324F – DECEMBER 1998 – REVISED MARCH 2003

receiver switching characteristics over recommended operating conditions (unless otherwise noted)

| PARAMETER           |   | TEST CONDITIONS                         | MIN | TYP† | MAX | UNIT |
|---------------------|---|---|-----|------|-----|------|
| t <sub>PLH</sub>    | Propagation delay time, low-to-high-level output            | C <sub>L</sub> = 10 pF,<br>See Figure 6 |     | 3.7  | 4.5 | ns   |
| t <sub>PHL</sub>    | Propagation delay time, high-to-low-level output            |   |     | 3.7  | 4.5 | ns   |
| t <sub>sk(p)</sub>  | Pulse skew ( t <sub>pHL</sub> – t <sub>pLH</sub>  )         |   |     | 0.1  |     | ns   |
| t <sub>sk(o)</sub>  | Channel-to-channel output skew                              |   |     | 0.2  |     | ns   |
| t <sub>sk(pp)</sub> | Part-to-part skew‡  |   |     |      | 1   | ns   |
| t <sub>r</sub>      | Output signal rise time                                     | C <sub>L</sub> = 10 pF,<br>See Figure 6 |     | 0.7  | 1.5 | ns   |
| t <sub>f</sub>      | Output signal fall time                                     |   |     | 0.9  | 1.5 | ns   |
| t <sub>PZH</sub>    | Propagation delay time, high-level-to-high-impedance output | See Figure 7                            |     | 2.5  |     | ns   |
| t <sub>PZL</sub>    | Propagation delay time, low-level-to-low-impedance output   |   |     | 2.5  |     | ns   |
| t <sub>PHZ</sub>    | Propagation delay time, high-impedance-to-high-level output |   |     | 7    |     | ns   |
| t <sub>PLZ</sub>    | Propagation delay time, low-impedance-to-high-level output  |   |     | 4    |     | ns   |

† All typical values are at 25°C and with a 3.3-V supply.

‡ t<sub>sk(pp)</sub> is the magnitude of the difference in propagation delay times between any specified terminals of two devices when both devices operate with the same supply voltages, at the same temperature, and have identical packages and test circuits.

## PARAMETER MEASUREMENT INFORMATION

driver

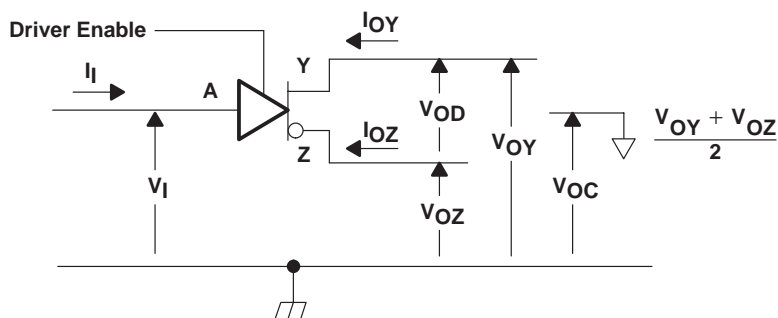

Figure 1. Driver Voltage and Current Definitions

# SN65LVDM179, SN65LVDM180, SN65LVDM050, SN65LVDM051 HIGH-SPEED DIFFERENTIAL LINE DRIVERS AND RECEIVERS

SLLS324F – DECEMBER 1998 – REVISED MARCH 2003

## PARAMETER MEASUREMENT INFORMATION

driver (continued)

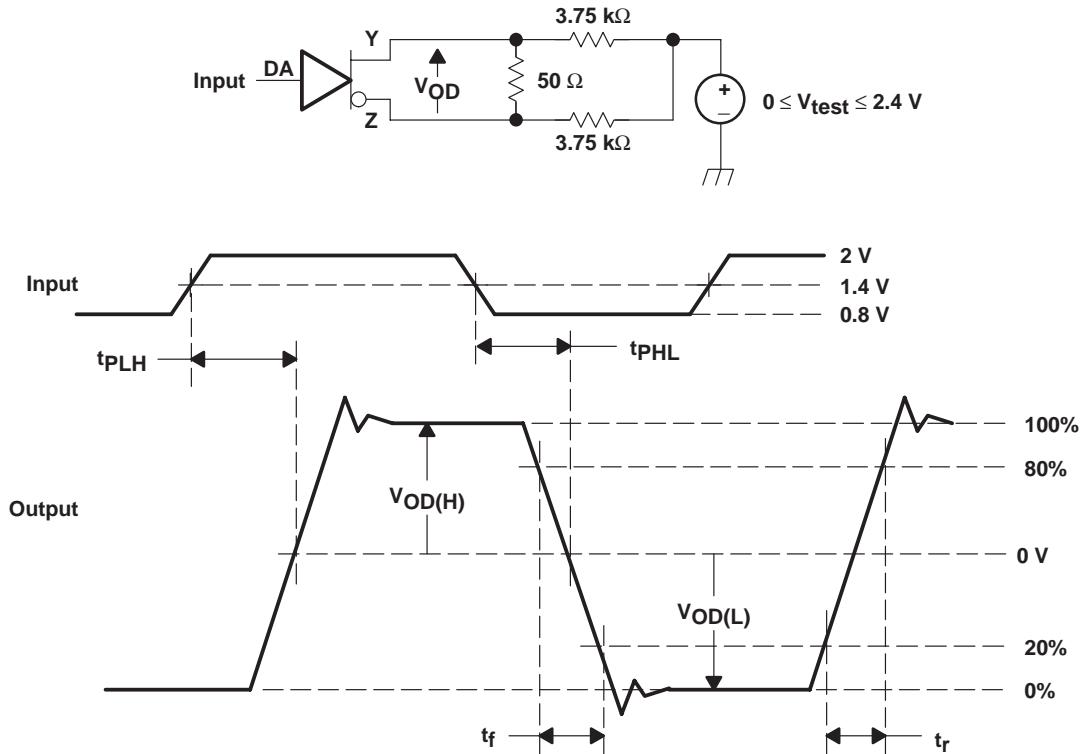

NOTE A: All input pulses are supplied by a generator having the following characteristics:  $t_r$  or  $t_f \leq 1$  ns, pulse repetition rate (PRR) = 50 Mpps, pulse width =  $10 \pm 0.2$  ns.  $C_L$  includes instrumentation and fixture capacitance within 0,06 mm of the D.U.T.

Figure 2. Test Circuit, Timing, and Voltage Definitions for the Differential Output Signal

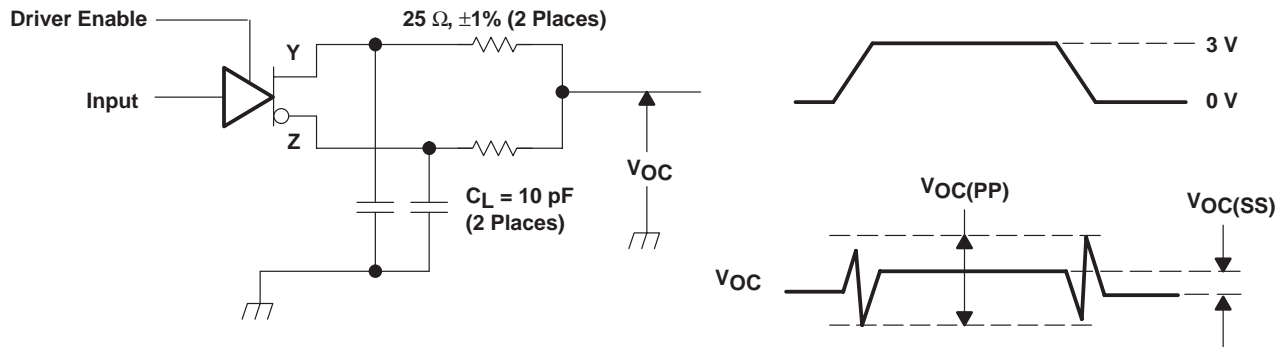

NOTE A: All input pulses are supplied by a generator having the following characteristics:  $t_r$  or  $t_f \leq 1$  ns, pulse repetition rate (PRR) = 50 Mpps, pulse width =  $10 \pm 0.2$  ns.  $C_L$  includes instrumentation and fixture capacitance within 0,06 mm of the D.U.T. The measurement of  $V_{OC(PP)}$  is made on test equipment with a  $-3$  dB bandwidth of at least 300 MHz.

Figure 3. Test Circuit and Definitions for the Driver Common-Mode Output Voltage

PARAMETER MEASUREMENT INFORMATION

driver (continued)

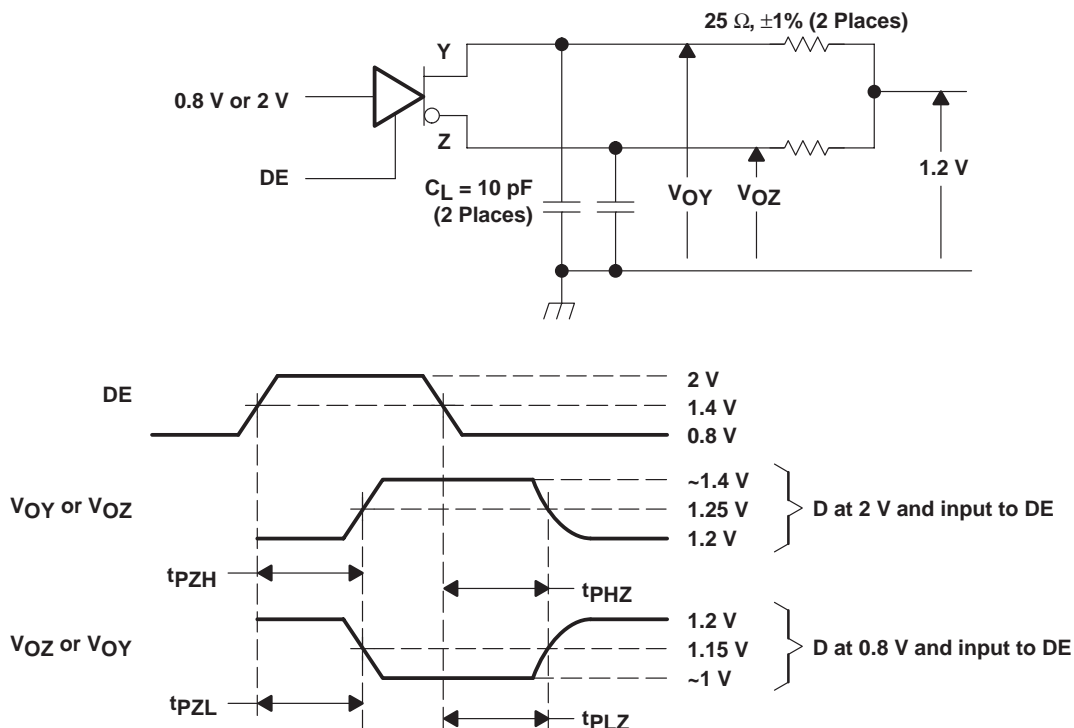

NOTE A: All input pulses are supplied by a generator having the following characteristics:  $t_r$  or  $t_f \leq 1 \text{ ns}$ , pulse repetition rate (PRR) = 0.5 Mpps, pulse width =  $500 \pm 10 \text{ ns}$ .  $C_L$  includes instrumentation and fixture capacitance within 0,06 mm of the D.U.T.

Figure 4. Enable and Disable Time Circuit and Definitions

# SN65LVDM179, SN65LVDM180, SN65LVDM050, SN65LVDM051 HIGH-SPEED DIFFERENTIAL LINE DRIVERS AND RECEIVERS

SLLS324F – DECEMBER 1998 – REVISED MARCH 2003

## PARAMETER MEASUREMENT INFORMATION

receiver

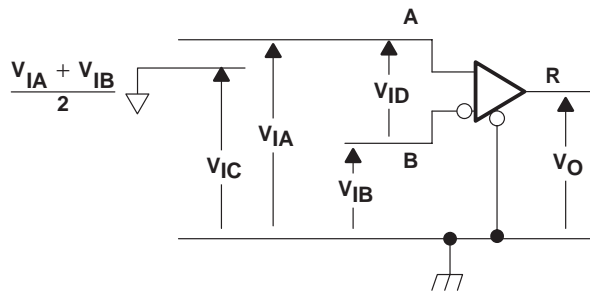

Figure 5. Receiver Voltage Definitions

Table 1. Receiver Minimum and Maximum Input Threshold Test Voltages

| APPLIED VOLTAGES (V) |          | RESULTING DIFFERENTIAL INPUT VOLTAGE (mV) | RESULTING COMMON-MODE INPUT VOLTAGE (V) |
|----------------------|----------|---|---|
| $V_{IA}$             | $V_{IB}$ | $V_{ID}$                                  | $V_{IC}$                                |
| 1.225                | 1.175    | 50  | 1.2                                     |
| 1.175                | 1.225    | -50                                       | 1.2                                     |
| 2.375                | 2.325    | 50  | 2.35                                    |
| 2.325                | 2.375    | -50                                       | 2.35                                    |
| 0.05                 | 0        | 50  | 0.05                                    |
| 0                    | 0.05     | -50                                       | 0.05                                    |
| 1.5                  | 0.9      | 600                                       | 1.2                                     |
| 0.9                  | 1.5      | -600                                      | 1.2                                     |
| 2.4                  | 1.8      | 600                                       | 2.1                                     |
| 1.8                  | 2.4      | -600                                      | 2.1                                     |
| 0.6                  | 0        | 600                                       | 0.3                                     |
| 0                    | 0.6      | -600                                      | 0.3                                     |

PARAMETER MEASUREMENT INFORMATION

receiver (continued)

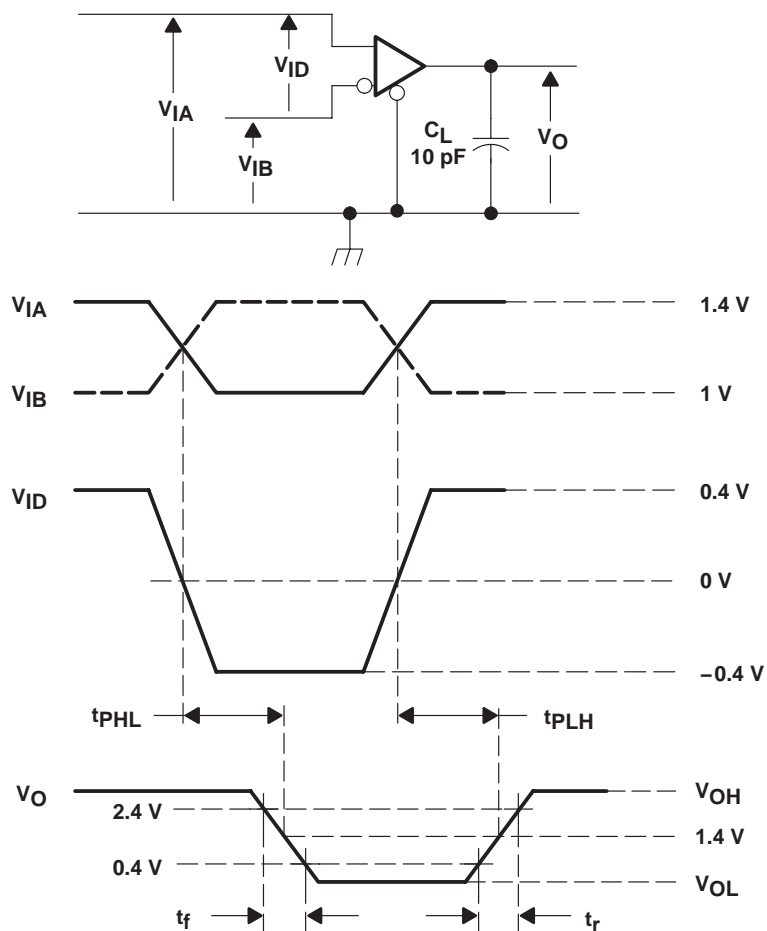

NOTE A: All input pulses are supplied by a generator having the following characteristics:  $t_r$  or  $t_f \leq 1$  ns, pulse repetition rate (PRR) = 50 Mpps, pulse width =  $10 \pm 0.2$  ns.  $C_L$  includes instrumentation and fixture capacitance within 0,06 mm of the D.U.T.

Figure 6. Timing Test Circuit and Waveforms

# SN65LVDM179, SN65LVDM180, SN65LVDM050, SN65LVDM051 HIGH-SPEED DIFFERENTIAL LINE DRIVERS AND RECEIVERS

SLLS324F – DECEMBER 1998 – REVISED MARCH 2003

## PARAMETER MEASUREMENT INFORMATION

receiver (continued)

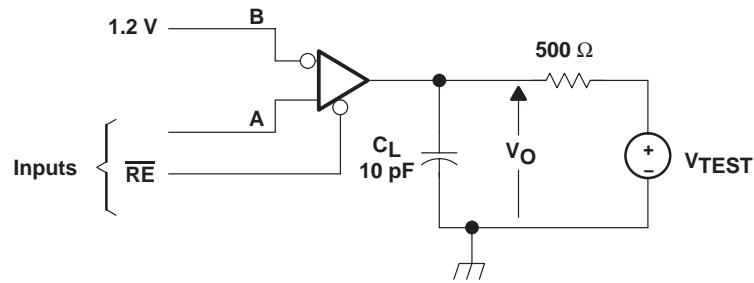

NOTE A: All input pulses are supplied by a generator having the following characteristics:  $t_r$  or  $t_f \leq 1$  ns, pulse repetition rate (PRR) = 0.5 Mpps, pulse width =  $500 \pm 10$  ns.  $C_L$  includes instrumentation and fixture capacitance within 0,06 mm of the D.U.T.

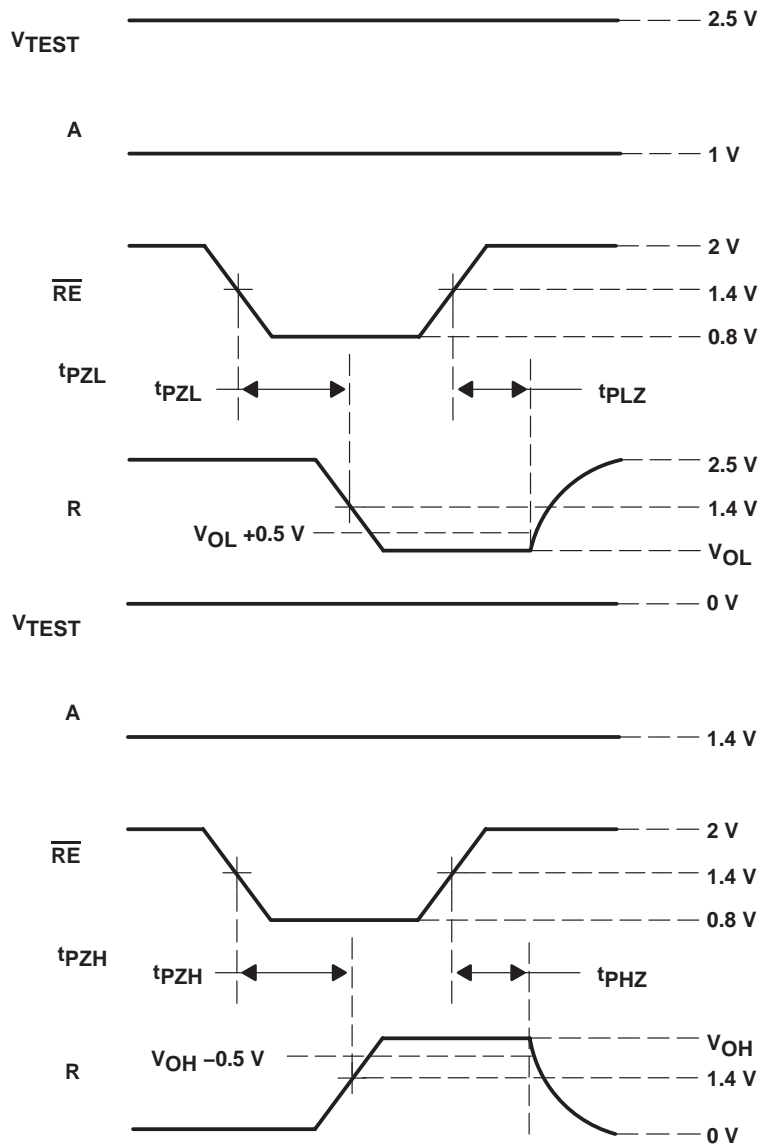
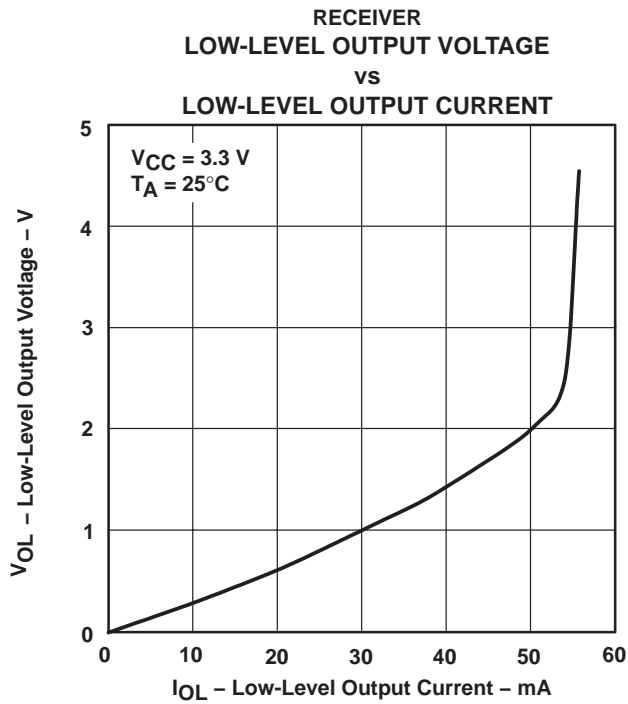
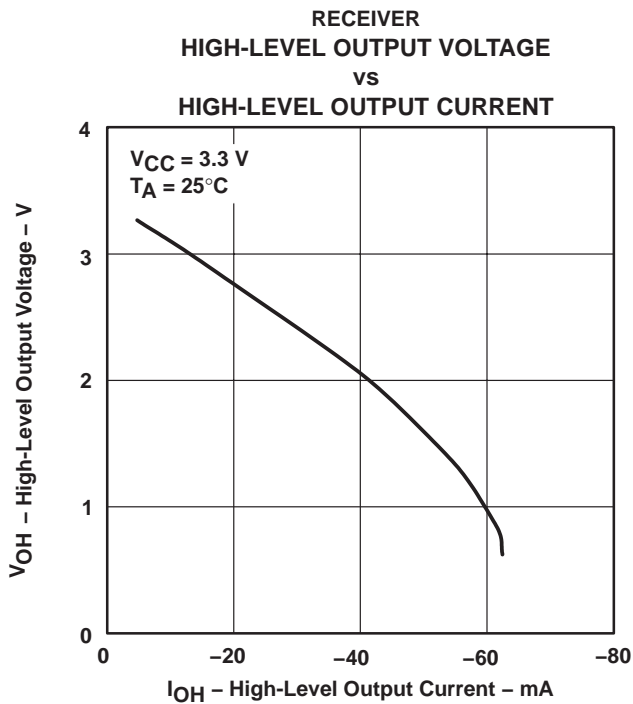
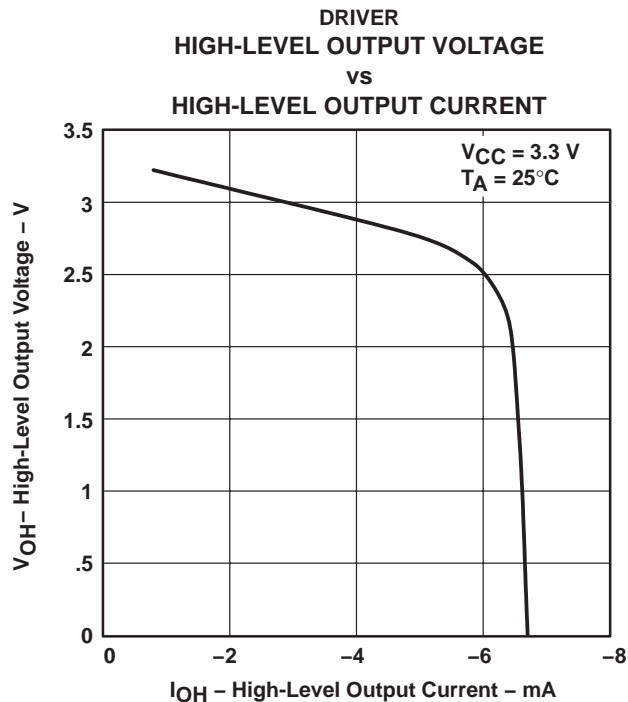
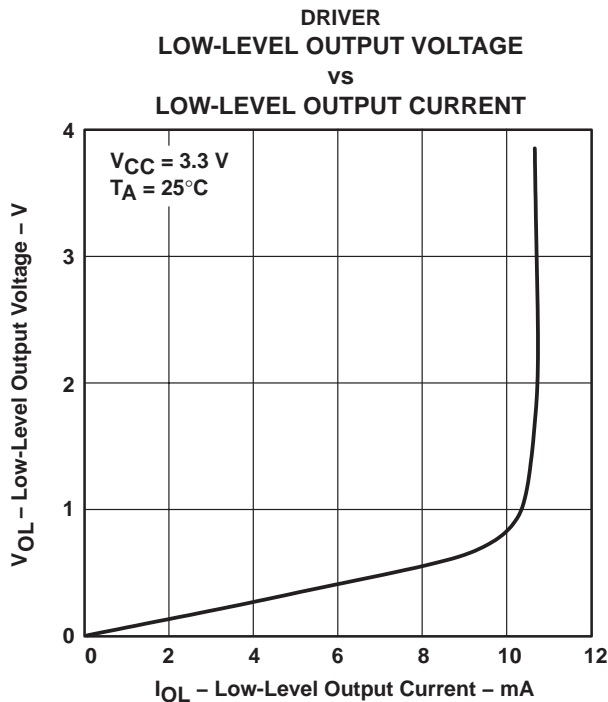

Figure 7. Enable/Disable Time Test Circuit and Waveforms

TYPICAL CHARACTERISTICS



# SN65LVDM179, SN65LVDM180, SN65LVDM050, SN65LVDM051 HIGH-SPEED DIFFERENTIAL LINE DRIVERS AND RECEIVERS

SLLS324F – DECEMBER 1998 – REVISED MARCH 2003

## TYPICAL CHARACTERISTICS

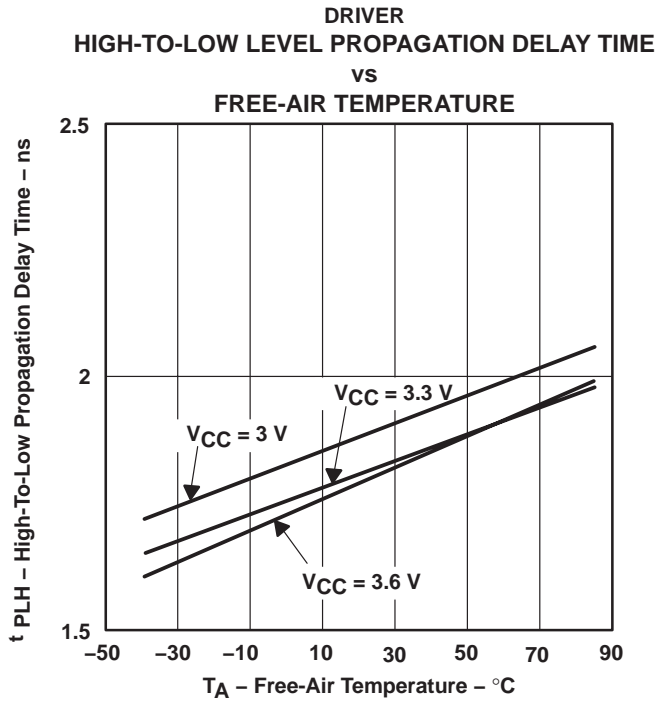

Figure 12

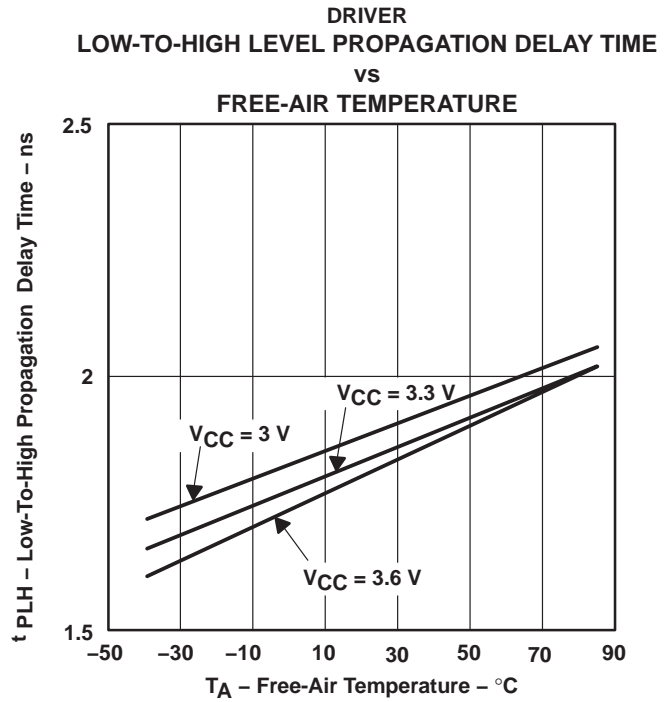

Figure 13

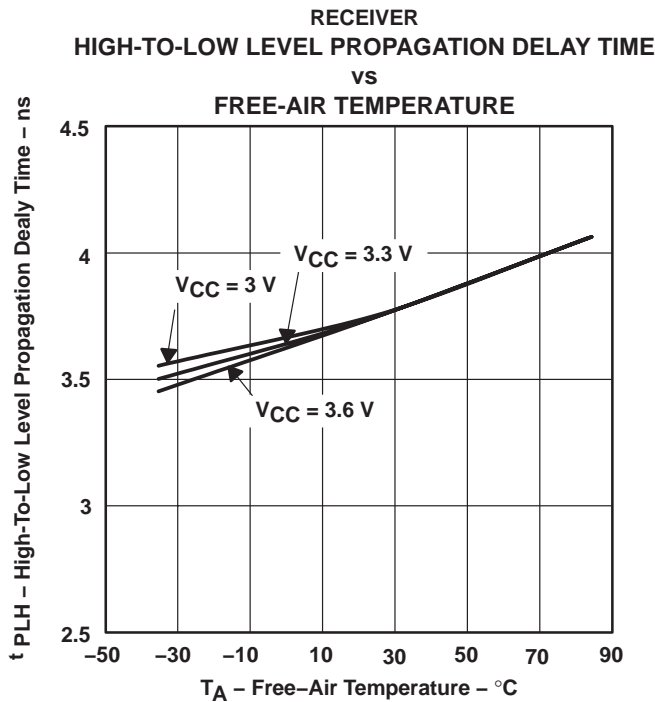

Figure 14

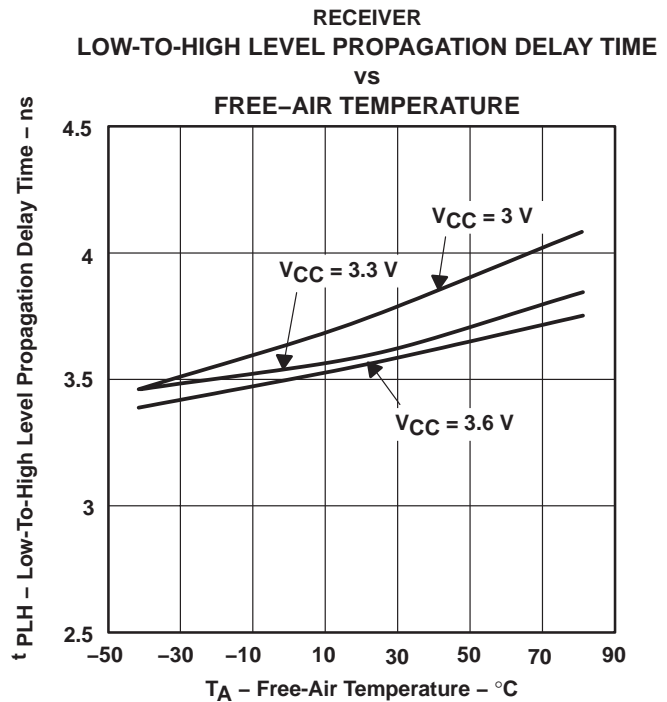

Figure 15



# SN65LVDM179, SN65LVDM180, SN65LVDM050, SN65LVDM051 HIGH-SPEED DIFFERENTIAL LINE DRIVERS AND RECEIVERS

SLLS324F – DECEMBER 1998 – REVISED MARCH 2003

## APPLICATION INFORMATION

The devices are generally used as building blocks for high-speed point-to-point data transmission. Ground differences are less than 1 V with a low common-mode output and balanced interface for very low noise emissions. Devices can interoperate with RS-422, PECL, and IEEE-P1596. Drivers/receivers maintain ECL speeds without the power and dual supply requirements.

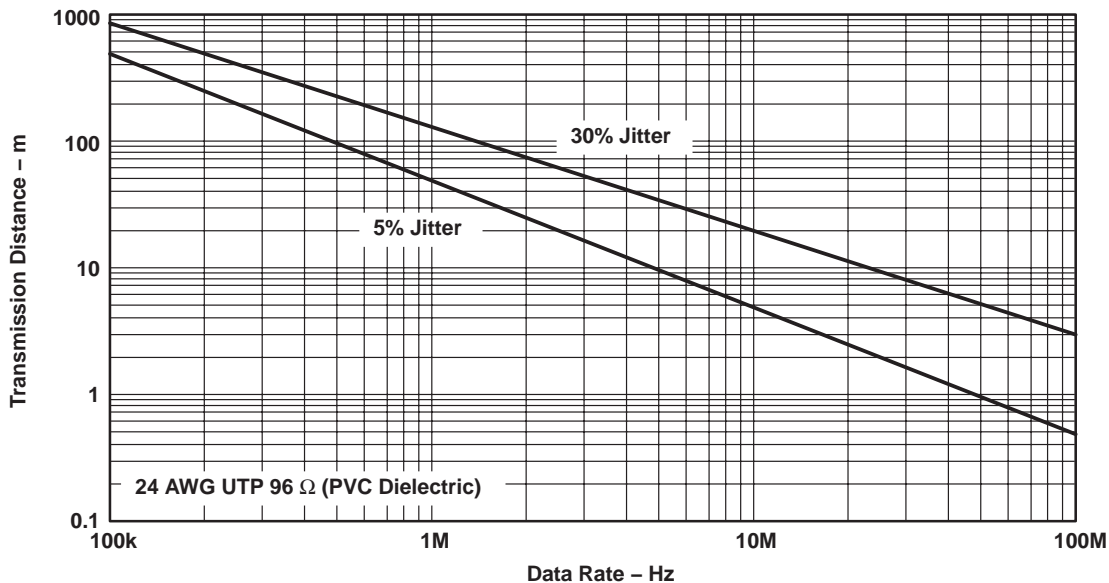

Figure 16. Data Transmission Distance Versus Rate

# SN65LVDM179, SN65LVDM180, SN65LVDM050, SN65LVDM051 HIGH-SPEED DIFFERENTIAL LINE DRIVERS AND RECEIVERS

SLLS324F – DECEMBER 1998 – REVISED MARCH 2003

## APPLICATION INFORMATION

### fail safe

One of the most common problems with differential signaling applications is how the system responds when no differential voltage is present on the signal pair. The LVDS receiver is like most differential line receivers, in that its output logic state can be indeterminate when the differential input voltage is between  $-50\text{ mV}$  and  $50\text{ mV}$  and within its recommended input common-mode voltage range. TI's LVDS receiver is different, however, in how it handles the open-input circuit situation.

Open-circuit means that there is little or no input current to the receiver from the data line itself. This could be when the driver is in a high-impedance state or the cable is disconnected. When this occurs, the LVDS receiver pulls each line of the signal pair to near  $V_{CC}$  through  $300\text{-k}\Omega$  resistors as shown in Figure 17. The fail-safe feature uses an AND gate with input voltage thresholds at about  $2.3\text{ V}$  to detect this condition and force the output to a high-level, regardless of the differential input voltage.

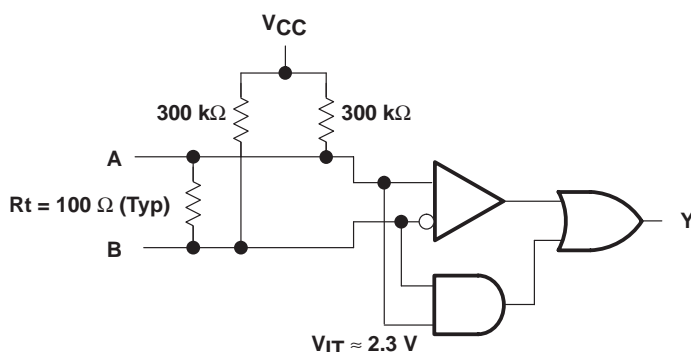

Figure 17. Open-Circuit Fail Safe of the LVDS Receiver

It is only under these conditions that the output of the receiver is valid with less than a  $50\text{-mV}$  differential input voltage magnitude. The presence of the termination resistor,  $R_t$ , does not affect the fail-safe function as long as it is connected as shown in the figure. Other termination circuits may allow a dc current to ground that could defeat the pullup currents from the receiver and the fail-safe feature.

**PACKAGING INFORMATION**

| Orderable Device | Status <sup>(1)</sup> | Package Type | Package Drawing | Pins | Package Qty | Eco Plan <sup>(2)</sup> | Lead/Ball Finish | MSL Peak Temp <sup>(3)</sup>              |
|------------------|-----------------------|--------------|-----------------|------|-------------|-------------------------|------------------|---|
| SN65LVDM050D     | ACTIVE                | SOIC         | D               | 16   | 40          | Pb-Free (RoHS)          | CU NIPDAU        | Level-2-260C-1YEAR/<br>Level-1-220C-UNLIM |
| SN65LVDM050DR    | ACTIVE                | SOIC         | D               | 16   | 2500        | Pb-Free (RoHS)          | CU NIPDAU        | Level-2-260C-1YEAR/<br>Level-1-220C-UNLIM |
| SN65LVDM050PW    | ACTIVE                | TSSOP        | PW              | 16   | 90          | None                    | CU NIPDAU        | Level-1-220C-UNLIM                        |
| SN65LVDM050PWR   | ACTIVE                | TSSOP        | PW              | 16   | 2000        | None                    | CU NIPDAU        | Level-1-220C-UNLIM                        |
| SN65LVDM051D     | ACTIVE                | SOIC         | D               | 16   | 40          | Pb-Free (RoHS)          | CU NIPDAU        | Level-2-260C-1YEAR/<br>Level-1-220C-UNLIM |
| SN65LVDM051DR    | ACTIVE                | SOIC         | D               | 16   | 2500        | Pb-Free (RoHS)          | CU NIPDAU        | Level-2-260C-1YEAR/<br>Level-1-220C-UNLIM |
| SN65LVDM051PW    | ACTIVE                | TSSOP        | PW              | 16   | 90          | None                    | CU NIPDAU        | Level-1-220C-UNLIM                        |
| SN65LVDM051PWR   | ACTIVE                | TSSOP        | PW              | 16   | 2000        | None                    | CU NIPDAU        | Level-1-220C-UNLIM                        |
| SN65LVDM179D     | ACTIVE                | SOIC         | D               | 8    | 75          | Pb-Free (RoHS)          | CU NIPDAU        | Level-2-260C-1YEAR/<br>Level-1-220C-UNLIM |
| SN65LVDM179DGK   | ACTIVE                | MSOP         | DGK             | 8    | 80          | None                    | CU NIPDAU        | Level-1-220C-UNLIM                        |
| SN65LVDM179DGKR  | ACTIVE                | MSOP         | DGK             | 8    | 2500        | None                    | CU NIPDAU        | Level-1-220C-UNLIM                        |
| SN65LVDM179DR    | ACTIVE                | SOIC         | D               | 8    | 2500        | Pb-Free (RoHS)          | CU NIPDAU        | Level-2-260C-1YEAR/<br>Level-1-220C-UNLIM |
| SN65LVDM180D     | ACTIVE                | SOIC         | D               | 14   | 50          | Pb-Free (RoHS)          | CU NIPDAU        | Level-2-260C-1YEAR/<br>Level-1-220C-UNLIM |
| SN65LVDM180DR    | ACTIVE                | SOIC         | D               | 14   | 2500        | Pb-Free (RoHS)          | CU NIPDAU        | Level-2-260C-1YEAR/<br>Level-1-220C-UNLIM |
| SN65LVDM180PW    | ACTIVE                | TSSOP        | PW              | 14   | 90          | None                    | CU NIPDAU        | Level-1-220C-UNLIM                        |
| SN65LVDM180PWR   | ACTIVE                | TSSOP        | PW              | 14   | 2000        | None                    | CU NIPDAU        | Level-1-220C-UNLIM                        |

<sup>(1)</sup> The marketing status values are defined as follows:

**ACTIVE:** Product device recommended for new designs.

**LIFEBUY:** TI has announced that the device will be discontinued, and a lifetime-buy period is in effect.

**NRND:** Not recommended for new designs. Device is in production to support existing customers, but TI does not recommend using this part in a new design.

**PREVIEW:** Device has been announced but is not in production. Samples may or may not be available.

**OBsolete:** TI has discontinued the production of the device.

<sup>(2)</sup> Eco Plan - May not be currently available - please check <http://www.ti.com/productcontent> for the latest availability information and additional product content details.

**None:** Not yet available Lead (Pb-Free).

**Pb-Free (RoHS):** TI's terms "Lead-Free" or "Pb-Free" mean semiconductor products that are compatible with the current RoHS requirements for all 6 substances, including the requirement that lead not exceed 0.1% by weight in homogeneous materials. Where designed to be soldered at high temperatures, TI Pb-Free products are suitable for use in specified lead-free processes.

**Green (RoHS & no Sb/Br):** TI defines "Green" to mean "Pb-Free" and in addition, uses package materials that do not contain halogens, including bromine (Br) or antimony (Sb) above 0.1% of total product weight.

<sup>(3)</sup> MSL, Peak Temp. -- The Moisture Sensitivity Level rating according to the JEDEC industry standard classifications, and peak solder temperature.

**Important Information and Disclaimer:** The information provided on this page represents TI's knowledge and belief as of the date that it is provided. TI bases its knowledge and belief on information provided by third parties, and makes no representation or warranty as to the accuracy of such information. Efforts are underway to better integrate information from third parties. TI has taken and continues to take reasonable steps to provide representative and accurate information but may not have conducted destructive testing or chemical analysis on incoming materials and chemicals. TI and TI suppliers consider certain information to be proprietary, and thus CAS numbers and other limited information may not be available for release.

In no event shall TI's liability arising out of such information exceed the total purchase price of the TI part(s) at issue in this document sold by TI to Customer on an annual basis.

DGK (S-PDSO-G8)

PLASTIC SMALL-OUTLINE PACKAGE

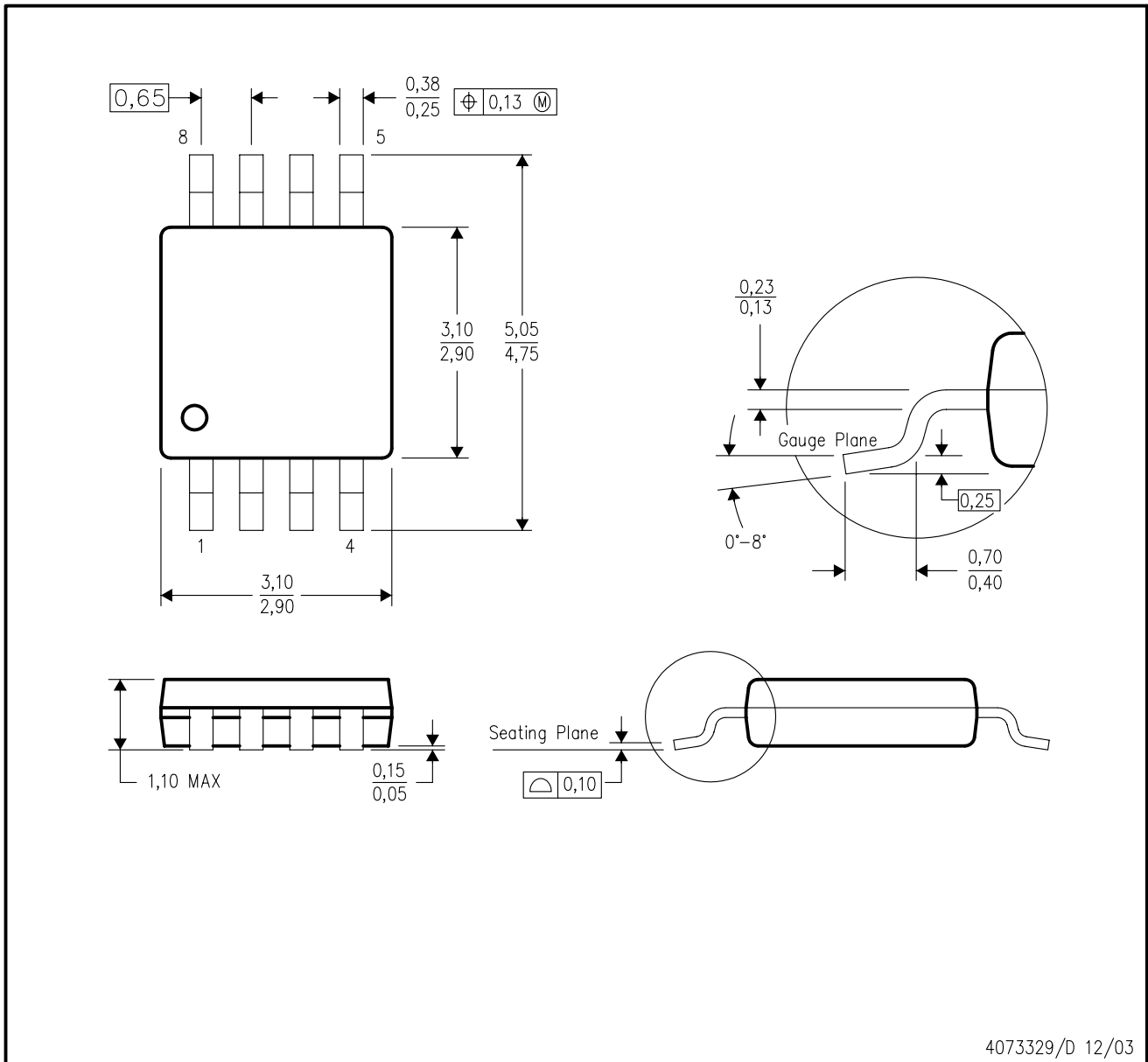

- NOTES:
- A. All linear dimensions are in millimeters.
  - B. This drawing is subject to change without notice.
  - C. Body dimensions do not include mold flash or protrusion.
  - D. Falls within JEDEC MO-187 variation AA.

D (R-PDSO-G14)

PLASTIC SMALL-OUTLINE PACKAGE

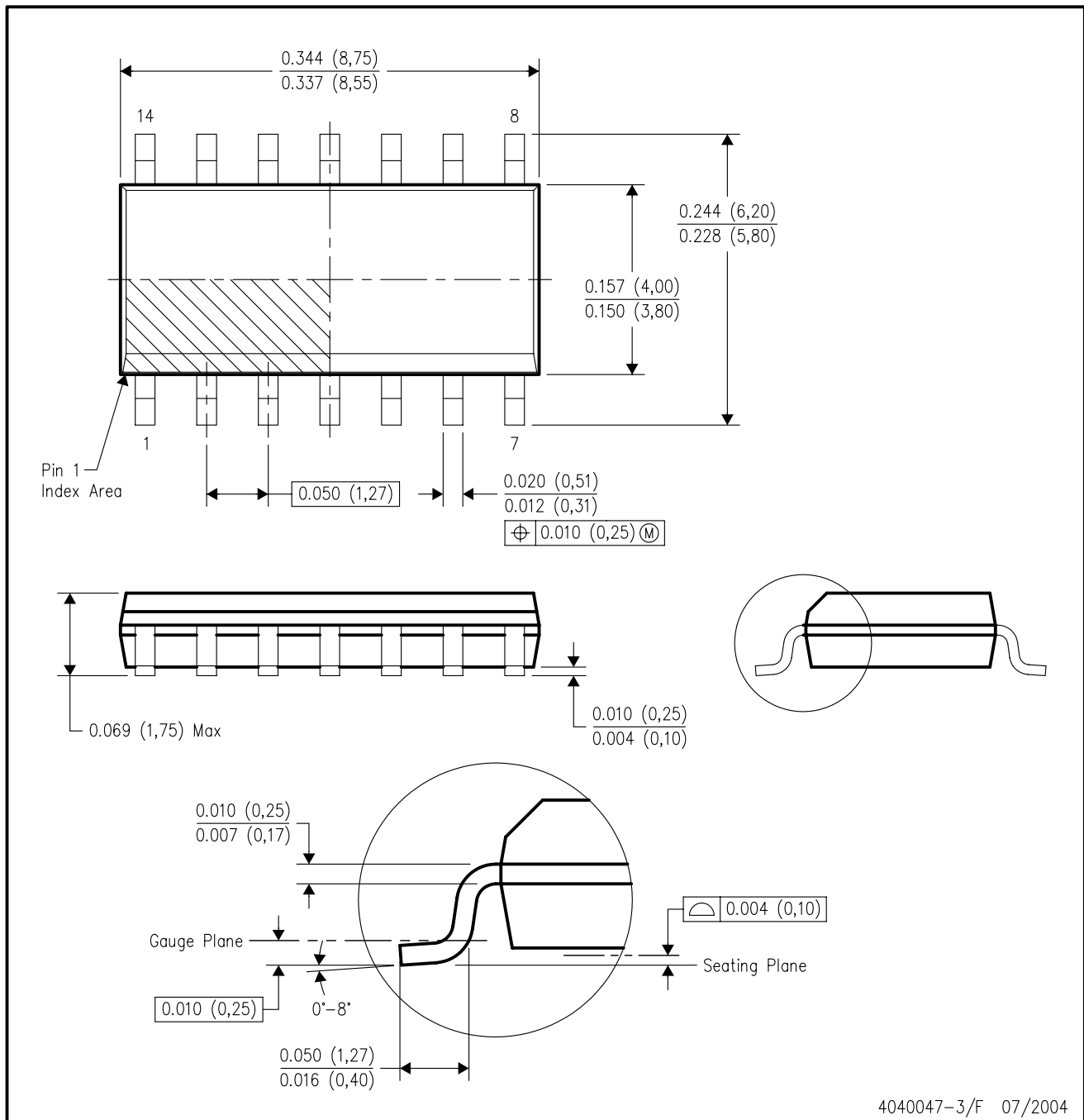

- NOTES:
- A. All linear dimensions are in inches (millimeters).
  - B. This drawing is subject to change without notice.
  - C. Body dimensions do not include mold flash or protrusion not to exceed 0.006 (0,15).
  - D. Falls within JEDEC MS-012 variation AB.

D (R-PDSO-G16)

PLASTIC SMALL-OUTLINE PACKAGE

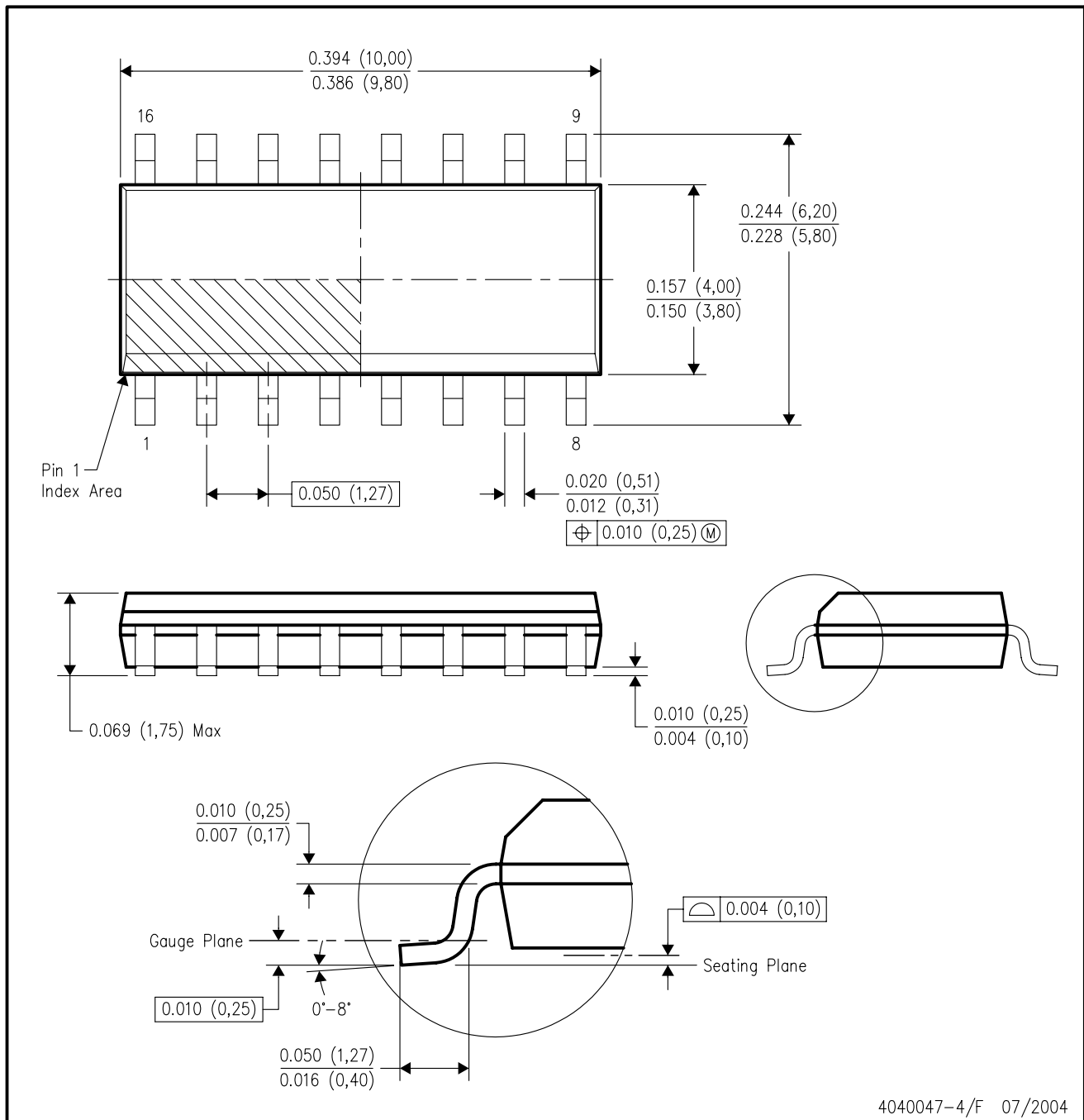

- NOTES:
- A. All linear dimensions are in inches (millimeters).
  - B. This drawing is subject to change without notice.
  - C. Body dimensions do not include mold flash or protrusion not to exceed 0.006 (0,15).
  - D. Falls within JEDEC MS-012 variation AC.

D (R-PDSO-G8)

PLASTIC SMALL-OUTLINE PACKAGE

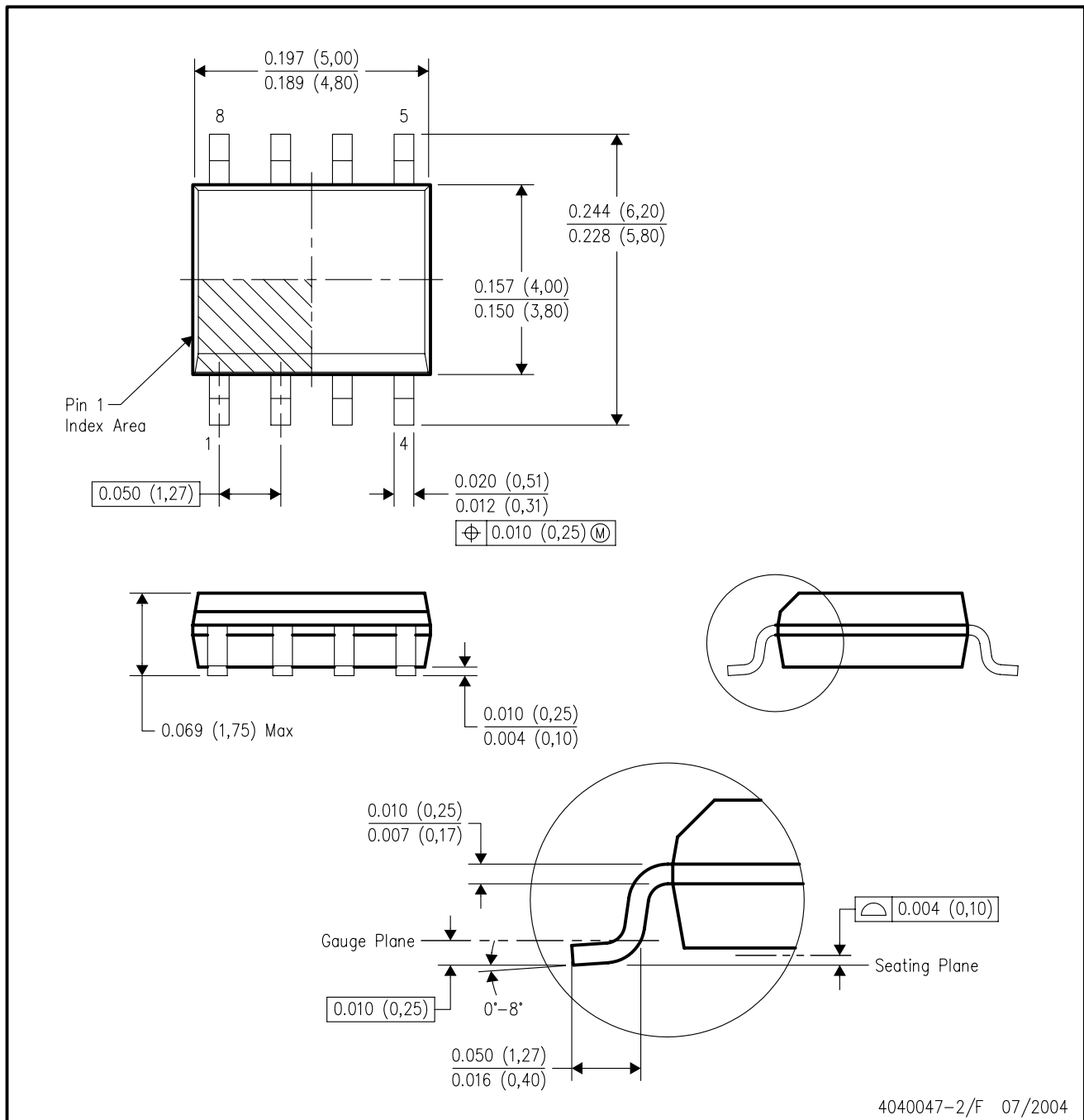

- NOTES:
- A. All linear dimensions are in inches (millimeters).
  - B. This drawing is subject to change without notice.
  - C. Body dimensions do not include mold flash or protrusion not to exceed 0.006 (0,15).
  - D. Falls within JEDEC MS-012 variation AA.

PW (R-PDSO-G\*\*)

PLASTIC SMALL-OUTLINE PACKAGE

14 PINS SHOWN



4040064/F 01/97

- NOTES: A. All linear dimensions are in millimeters.  
 B. This drawing is subject to change without notice.  
 C. Body dimensions do not include mold flash or protrusion not to exceed 0,15.  
 D. Falls within JEDEC MO-153

## IMPORTANT NOTICE

Texas Instruments Incorporated and its subsidiaries (TI) reserve the right to make corrections, modifications, enhancements, improvements, and other changes to its products and services at any time and to discontinue any product or service without notice. Customers should obtain the latest relevant information before placing orders and should verify that such information is current and complete. All products are sold subject to TI's terms and conditions of sale supplied at the time of order acknowledgment.

TI warrants performance of its hardware products to the specifications applicable at the time of sale in accordance with TI's standard warranty. Testing and other quality control techniques are used to the extent TI deems necessary to support this warranty. Except where mandated by government requirements, testing of all parameters of each product is not necessarily performed.

TI assumes no liability for applications assistance or customer product design. Customers are responsible for their products and applications using TI components. To minimize the risks associated with customer products and applications, customers should provide adequate design and operating safeguards.

TI does not warrant or represent that any license, either express or implied, is granted under any TI patent right, copyright, mask work right, or other TI intellectual property right relating to any combination, machine, or process in which TI products or services are used. Information published by TI regarding third-party products or services does not constitute a license from TI to use such products or services or a warranty or endorsement thereof. Use of such information may require a license from a third party under the patents or other intellectual property of the third party, or a license from TI under the patents or other intellectual property of TI.

Reproduction of information in TI data books or data sheets is permissible only if reproduction is without alteration and is accompanied by all associated warranties, conditions, limitations, and notices. Reproduction of this information with alteration is an unfair and deceptive business practice. TI is not responsible or liable for such altered documentation.

Resale of TI products or services with statements different from or beyond the parameters stated by TI for that product or service voids all express and any implied warranties for the associated TI product or service and is an unfair and deceptive business practice. TI is not responsible or liable for any such statements.

Following are URLs where you can obtain information on other Texas Instruments products and application solutions:

| <b>Products</b>  |  | <b>Applications</b> |  |
|------------------|--|---------------------|--|
| Amplifiers       | <a href="http://amplifier.ti.com">amplifier.ti.com</a>             | Audio               | <a href="http://www.ti.com/audio">www.ti.com/audio</a>                   |
| Data Converters  | <a href="http://dataconverter.ti.com">dataconverter.ti.com</a>     | Automotive          | <a href="http://www.ti.com/automotive">www.ti.com/automotive</a>         |
| DSP              | <a href="http://dsp.ti.com">dsp.ti.com</a>                         | Broadband           | <a href="http://www.ti.com/broadband">www.ti.com/broadband</a>           |
| Interface        | <a href="http://interface.ti.com">interface.ti.com</a>             | Digital Control     | <a href="http://www.ti.com/digitalcontrol">www.ti.com/digitalcontrol</a> |
| Logic            | <a href="http://logic.ti.com">logic.ti.com</a>                     | Military            | <a href="http://www.ti.com/military">www.ti.com/military</a>             |
| Power Mgmt       | <a href="http://power.ti.com">power.ti.com</a>                     | Optical Networking  | <a href="http://www.ti.com/opticalnetwork">www.ti.com/opticalnetwork</a> |
| Microcontrollers | <a href="http://microcontroller.ti.com">microcontroller.ti.com</a> | Security            | <a href="http://www.ti.com/security">www.ti.com/security</a>             |
|                  |  | Telephony           | <a href="http://www.ti.com/telephony">www.ti.com/telephony</a>           |
|                  |  | Video & Imaging     | <a href="http://www.ti.com/video">www.ti.com/video</a>                   |
|                  |  | Wireless            | <a href="http://www.ti.com/wireless">www.ti.com/wireless</a>             |

Mailing Address: Texas Instruments  
Post Office Box 655303 Dallas, Texas 75265