

# SN65LVDS047 LVDS QUAD DIFFERENTIAL LINE DRIVER

SLLS416A – JUNE 2000 – REVISED MAY 2001

- >400 Mbps (200 MHz) Signaling Rates
- Flow-Through Pinout Simplifies PCB Layout
- 300 ps Maximum Differential Skew
- Propagation Delay Times 1.8 ns (Typical)
- 3.3 V Power Supply Design
- $\pm 350$  mV Differential Signaling
- High Impedance on LVDS Outputs on Power Down
- Conforms to TIA/EIA-644 LVDS Standard
- Industrial Operating Temperature Range ( $-40^{\circ}\text{C}$  to  $85^{\circ}\text{C}$ )
- Available in SOIC and TSSOP Packages

D OR PW PACKAGE  
(Marked as LVDS047)  
(TOP VIEW)

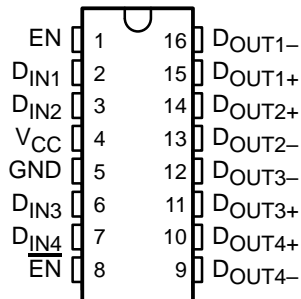

## description

The SN65LVDS047 is a quad differential line driver that implements the electrical characteristics of low-voltage differential signaling (LVDS). This signaling technique lowers the output voltage levels of 5-V differential standard levels (such as EIA/TIA-422B) to reduce the power, increase the switching speeds, and allow operation with a 3.3-V supply rail. Any of the four current-mode drivers will deliver a minimum differential output voltage magnitude of 247 mV into a 100- $\Omega$  load when enabled.

The intended application of this device and signaling technique is for point-to-point and multi-drop baseband data transmission over controlled impedance media of approximately 100  $\Omega$ . The transmission media may be printed-circuit board traces, backplanes, or cables. The ultimate rate and distance of data transfer is dependent upon the attenuation characteristics of the media, the noise coupling to the environment, and other system characteristics.

The SN65LVDS047 is characterized for operation from  $-40^{\circ}\text{C}$  to  $85^{\circ}\text{C}$ .

## functional block diagram

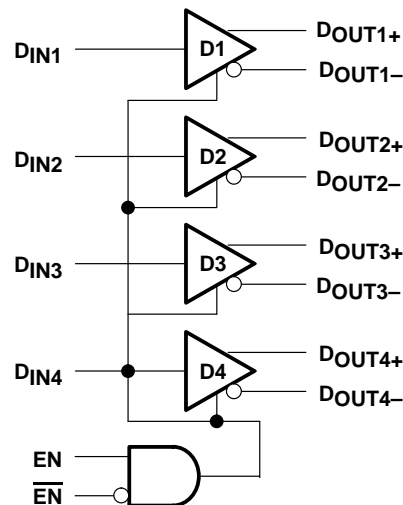

## TRUTH TABLE

INPUT	ENABLES		OUTPUTS	
	DIN	EN	$\overline{\text{EN}}$	DOUT+
L	H	L or OPEN	L	H
H			H	L
X	All other conditions		Z	Z

H = high level, L = low level, X = irrelevant,  
Z = high impedance (off)



Please be aware that an important notice concerning availability, standard warranty, and use in critical applications of Texas Instruments semiconductor products and disclaimers thereto appears at the end of this data sheet.

PRODUCTION DATA information is current as of publication date. Products conform to specifications per the terms of Texas Instruments standard warranty. Production processing does not necessarily include testing of all parameters.

 **TEXAS  
INSTRUMENTS**

POST OFFICE BOX 655303 • DALLAS, TEXAS 75265

Copyright © 2001, Texas Instruments Incorporated

# SN65LVDS047 LVDS QUAD DIFFERENTIAL LINE DRIVER

SLLS416A – JUNE 2000 – REVISED MAY 2001

## equivalent input and output schematic diagrams

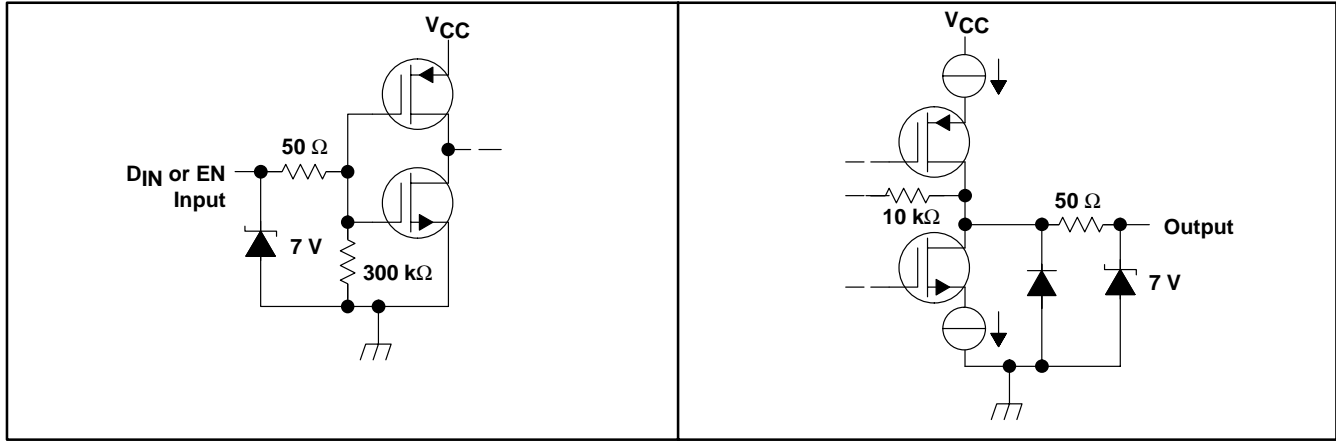

## absolute maximum ratings over operating free-air temperature (see Note 1) (unless otherwise noted)†

Supply voltage ( $V_{CC}$ )	.....	-0.3 V to 4 V
Input voltage range, $V_I(D_{IN})$	.....	-0.3 V to ( $V_{CC} + 0.3$ V)
Enable input voltage (EN, $\overline{EN}$ )	.....	-0.3 V to ( $V_{CC} + 0.3$ V)
Output voltage, $V_O(D_{OUT+}, D_{OUT-})$	.....	-0.3 V to 3.9 V
Bus-pin ( $D_{OUT+}, D_{OUT-}$ ) electrostatic discharge, (see Note 2)	.....	>10 kV
Short circuit duration ( $D_{OUT+}, D_{OUT-}$ )	.....	Continuous
Storage temperature range	.....	-65°C to 150°C
Lead temperature 1,6 mm (1/16 inch) from case for 10 seconds	.....	260°C

† Stresses beyond those listed under “absolute maximum ratings” may cause permanent damage to the device. These are stress ratings only, and functional operation of the device at these or any other conditions beyond those indicated under “recommended operating conditions” is not implied. Exposure to absolute-maximum-rated conditions for extended periods may affect device reliability.

- NOTES: 1. All voltage values, except differential I/O bus voltages, are with respect to network ground terminal.  
2. Tested in accordance with MIL-STD-883C Method 3015.7.

DISSIPATION RATING TABLE

PACKAGE	$T_A \leq 25^\circ\text{C}$ POWER RATING	OPERATING FACTOR‡ ABOVE $T_A = 25^\circ\text{C}$	$T_A = 85^\circ\text{C}$ POWER RATING
D	950 mW	7.6 mW/°C	494 mW
PW	774 mW	6.2 mW/°C	402 mW

‡ This is the inverse of the junction-to-ambient thermal resistance when board-mounted and with no air flow.

## recommended operating conditions

	MIN	NOM	MAX	UNIT
Supply voltage, $V_{CC}$	3	3.3	3.6	V
Operating free-air temperature, $T_A$	-40	25	85	°C



# SN65LVDS047

## LVDS QUAD DIFFERENTIAL LINE DRIVER

SLLS416A – JUNE 2000 – REVISED MAY 2001

### electrical characteristics over recommended operating free-air temperature range (see Notes 3, 4) (unless otherwise noted)

PARAMETER		TEST CONDITIONS	MIN	TYP†	MAX	UNIT
$V_{OD}$	Differential output voltage	$R_L = 100 \Omega$ (see Figure 1)	250	310	450	mV
$\Delta V_{OD} $	Change in magnitude of $V_{OD}$ for complementary output states			1	35	mV
$V_{OC(SS)}$	Steady-state, common-mode output voltage		1.125	1.17	1.375	V
$\Delta V_{OC(SS)}$	Change in steady-state common-mode output voltage between logic states			1	25	mV
$V_{OH}$	Output high voltage			1.33	1.6	V
$V_{OL}$	Output low voltage		0.90	1.02		V
$V_{IH}$	Input high voltage			2	$V_{CC}$	V
$V_{IL}$	Input low voltage		GND	0.8	V	
$I_{IH}$	Input high current	$V_{IN} = V_{CC}$ or 2.5 V	-10	3	10	$\mu$ A
$I_{IL}$	Input low current	$V_{IN} = GND$ or 0.4 V	-10	1	10	$\mu$ A
$V_{IK}$	Input clamp voltage	$I_{CL} = -18$ mA	-1.5	-0.8		V
$I_{OS}$	Output short circuit current (see Note 5)	Enabled, $D_{IN} = V_{CC}$ , $D_{OUT+} = 0$ V or $D_{IN} = GND$ , $D_{OUT-} = 0$ V		-3.1	-9	mA
$I_{OSD}$	Differential output short circuit current (see Note 5)	Enabled, $V_{OD} = 0$ V			-9	mA
$I_{OFF}$	Power-off leakage	$V_O = 0$ V or 3.6 V, $V_{CC} = 0$ V or Open	-1		1	$\mu$ A
$I_{OZ}$	Output 3-state current	$EN = 0.8$ V and $\overline{EN} = 2$ V, $V_O = 0$ V or $V_{CC}$	-1		1	$\mu$ A
$I_{CC}$	No load supply current, drivers enabled	$D_{IN} = V_{CC}$ or GND		7		mA
$I_{CCL}$	Loaded supply current, drivers enabled	$R_L = 100 \Omega$ all channels, $D_{IN} = V_{CC}$ or GND (all inputs)		20	26	mA
$I_{CC(Z)}$	No load supply current, drivers disabled	$D_{IN} = V_{CC}$ or GND, $EN = GND$ , $\overline{EN} = V_{CC}$		0.5	1.3	mA

† All typical values are given for:  $V_{CC} = 3.3$  V,  $T_A = 25^\circ$ C.

- NOTES:
- Current into device pin is defined as positive. Current out of the device is defined as negative. All voltages are referenced to ground, unless otherwise specified.
  - The SN65LVDS047 is a current mode device and only functions within data sheet specifications when a resistive load is applied to the driver outputs, 90  $\Omega$  to 110  $\Omega$  typical range.
  - Output short circuit current ( $I_{OS}$ ) is specified as magnitude only, minus sign indicates direction only.

# SN65LVDS047

## LVDS QUAD DIFFERENTIAL LINE DRIVER

SLLS416A – JUNE 2000 – REVISED MAY 2001

switching characteristics over recommended operating conditions (see Notes 6, 7, and 12) (unless otherwise noted)

PARAMETER		TEST CONDITIONS	MIN	TYP†	MAX	UNIT
t <sub>PHL</sub>	Differential propagation delay, high-to-low	R <sub>L</sub> = 100 Ω, C <sub>L</sub> = 15 pF (see Figures 2 and 3)	1.4	1.8	2.8	ns
t <sub>PLH</sub>	Differential propagation delay, low-to-high		1.4	1.8	2.8	ns
t <sub>SK(p)</sub>	Differential pulse skew (t <sub>PHLD</sub> – t <sub>PLHD</sub> ) (see Note 8)			50	300	ps
t <sub>SK(o)</sub>	Channel-to-channel skew (see Note 9)			40	300	ps
t <sub>SK(pp)</sub>	Differential part-to-part skew (see Note 10)				1	ns
t <sub>SK(lim)</sub>	Differential part-to-part skew (see Note 11)				1.2	ns
t <sub>r</sub>	Rise time			0.5	1.5	ns
t <sub>f</sub>	Fall time			0.5	1.5	ns
t <sub>PHZ</sub>	Disable time high to Z	R <sub>L</sub> = 100 Ω, C <sub>L</sub> = 15 pF (see Figures 4 and 5)		5.5	8	ns
t <sub>PLZ</sub>	Disable time low to Z			5.5	8	ns
t <sub>PZH</sub>	Enable time Z to high			8.5	12	ns
t <sub>PZL</sub>	Enable time Z to low			8.5	12	ns
f <sub>(MAX)</sub>	Maximum operating frequency (see Note 13)			250		MHz

† All typical values are given for: V<sub>CC</sub> = 3.3 V, T<sub>A</sub> = 25°C.

NOTES: 6. Generator waveform for all tests unless otherwise: f = 1 MHz, Z<sub>O</sub> = 50 Ω, t<sub>r</sub> < 1 ns, and t<sub>f</sub> < 1 ns.

7. C<sub>L</sub> includes probe and jig capacitance.
8. t<sub>SK(p)</sub>|t<sub>PHL</sub>–t<sub>PLH</sub>| is the magnitude difference in differential propagation delay time between the positive going edge and the negative going edge of the same channel.
9. t<sub>SK(o)</sub> is the differential channel-to-channel skew of any event on the same device.
10. t<sub>SK(pp)</sub> is the differential part-to-part skew, and is defined as the difference between the minimum and the maximum specified differential propagation delays. This specification applies to devices at the same V<sub>CC</sub> and within 5°C of each other within the operating temperature range.
11. t<sub>SK(lim)</sub> part-to-part skew, is the differential channel-to-channel skew of any event between devices. This specification applies to devices over recommended operating temperature and voltage ranges, and across process distribution. t<sub>SK(lim)</sub> is defined as |Min – Max| differential propagation delay.
12. All input voltages are for one channel unless otherwise specified. Other inputs are set to GND.
13. f<sub>(MAX)</sub> generator input conditions: t<sub>r</sub> = t<sub>f</sub> < 1 ns (0% to 100%), 50% duty cycle, 0 V to 3 V. Output criteria: duty cycle = 45% to 55, V<sub>OD</sub> > 250 mV, all channels switching



PARAMETER MEASUREMENT INFORMATION

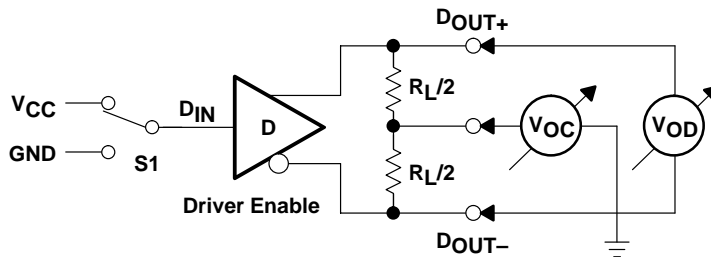

Figure 1. Driver  $V_{OD}$  and  $V_{OC}$  Test Circuit

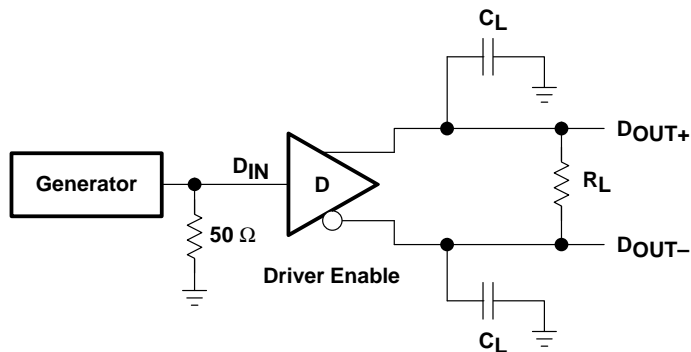

Figure 2. Driver Propagation Delay and Transition Time Test Circuit

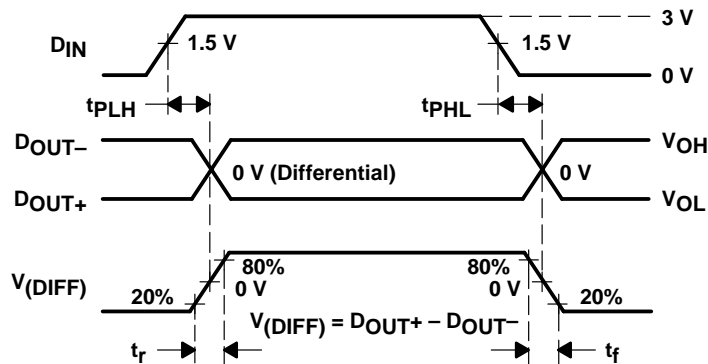

Figure 3. Driver Propagation Delay and Transition Time Waveforms

# SN65LVDS047 LVDS QUAD DIFFERENTIAL LINE DRIVER

SLLS416A – JUNE 2000 – REVISED MAY 2001

## PARAMETER MEASUREMENT INFORMATION

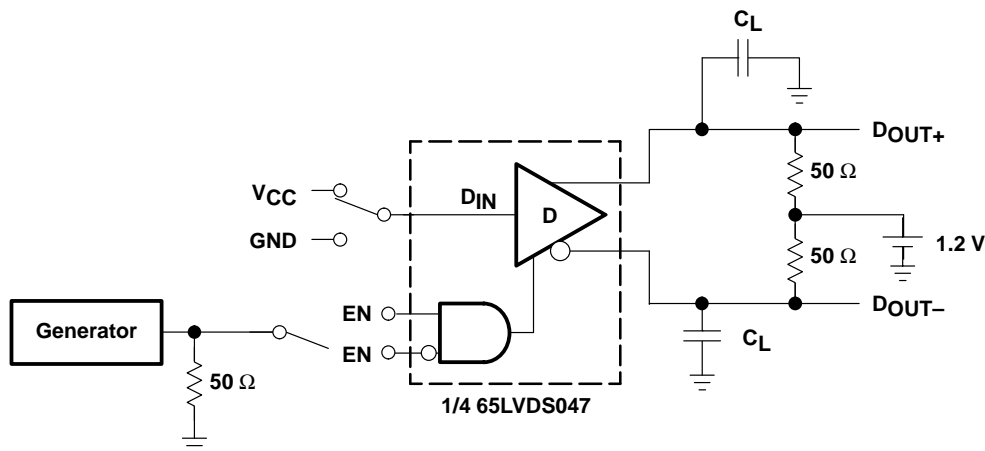

Figure 4. Driver 3-State Delay Test Circuit

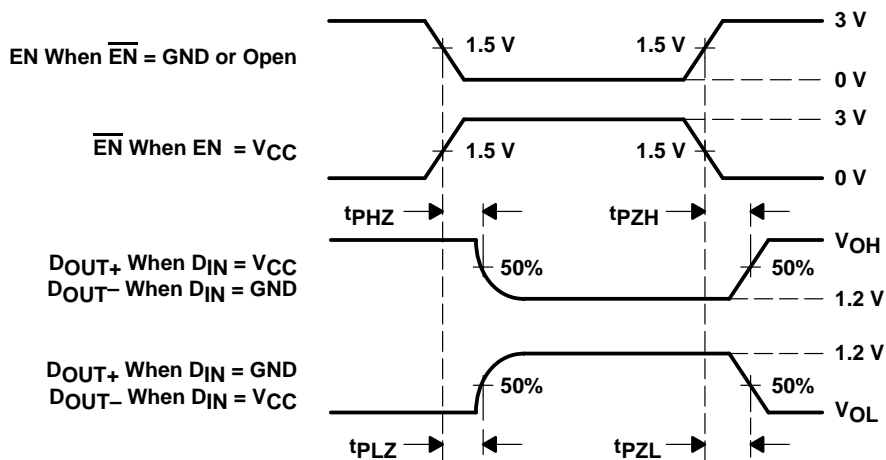

Figure 5. Driver 3-State Delay Waveform

TYPICAL CHARACTERISTICS

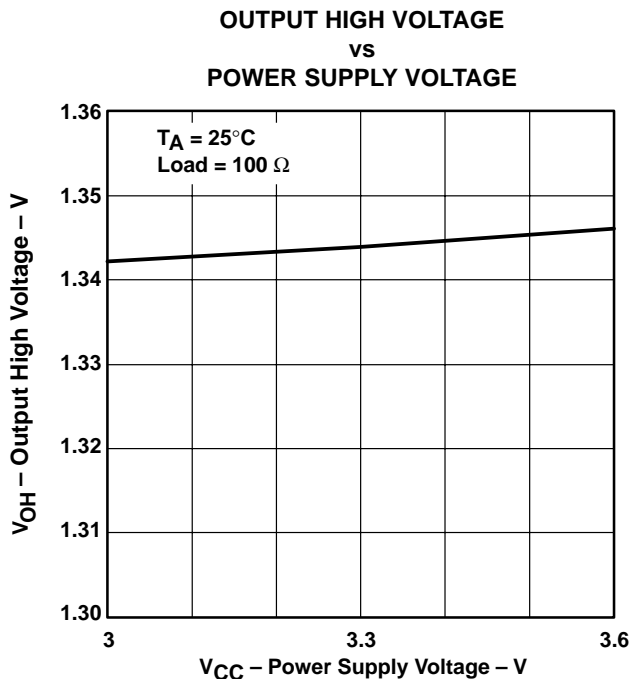

Figure 6

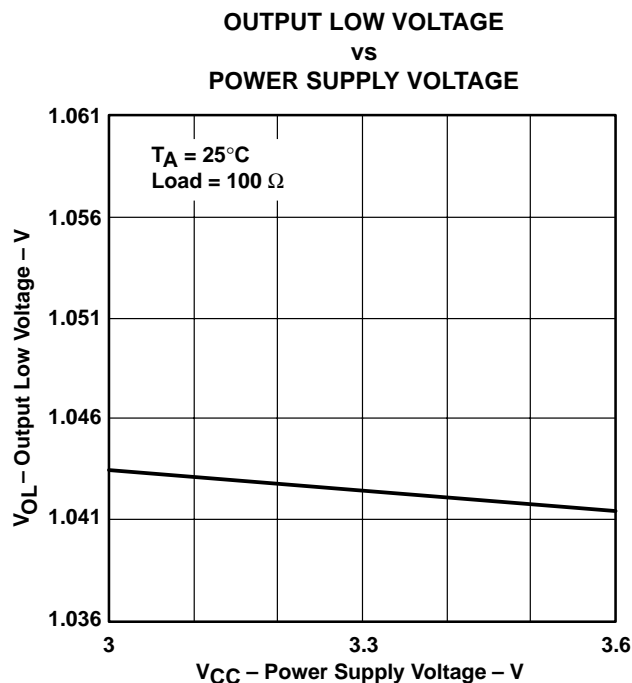

Figure 7

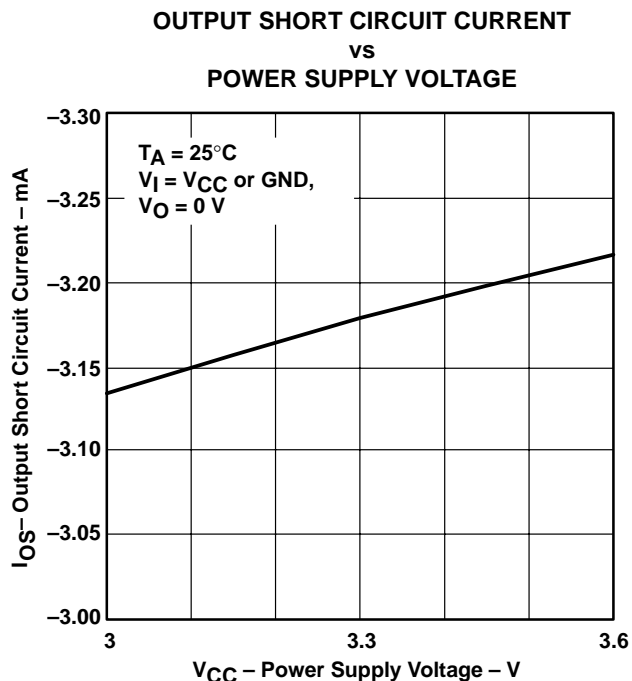

Figure 8

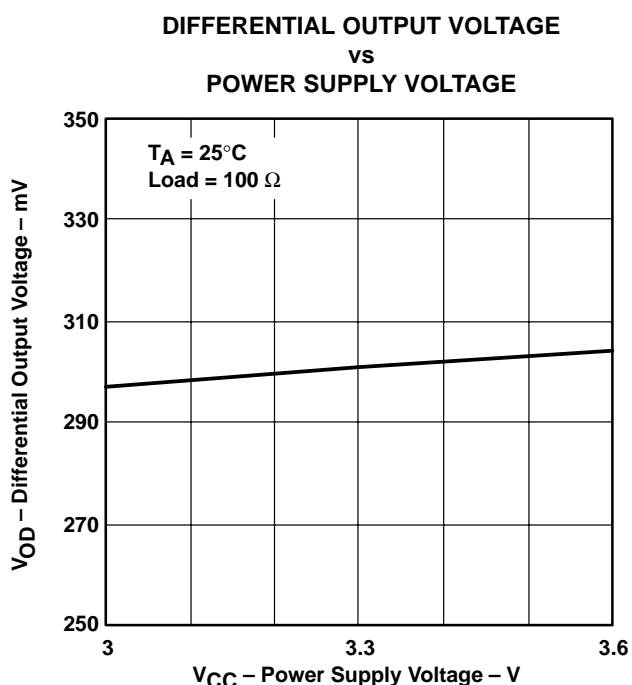

Figure 9

# SN65LVDS047 LVDS QUAD DIFFERENTIAL LINE DRIVER

SLLS416A – JUNE 2000 – REVISED MAY 2001

## TYPICAL CHARACTERISTICS

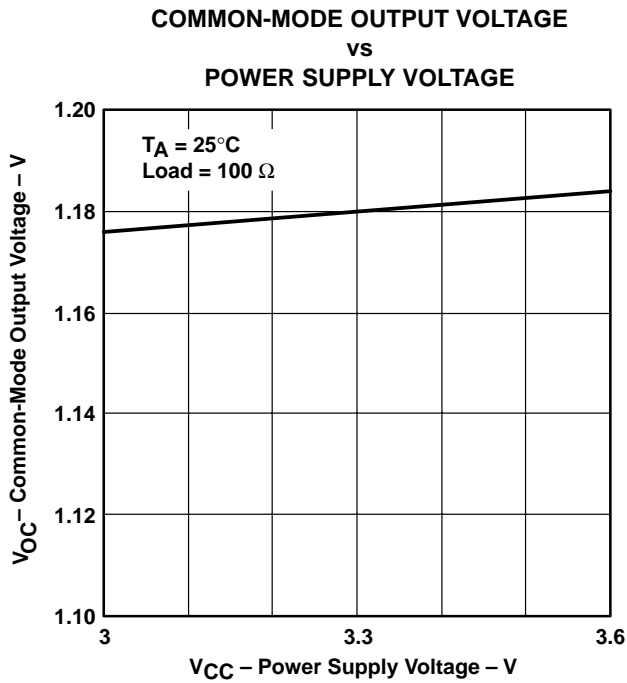

Figure 10

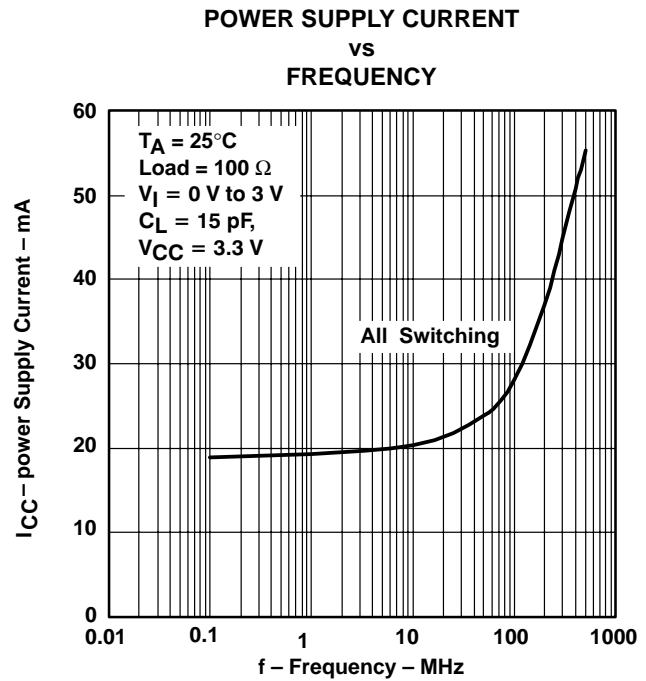

Figure 11

MECHANICAL DATA

D (R-PDSO-G\*\*)

PLASTIC SMALL-OUTLINE PACKAGE

14 PINS SHOWN

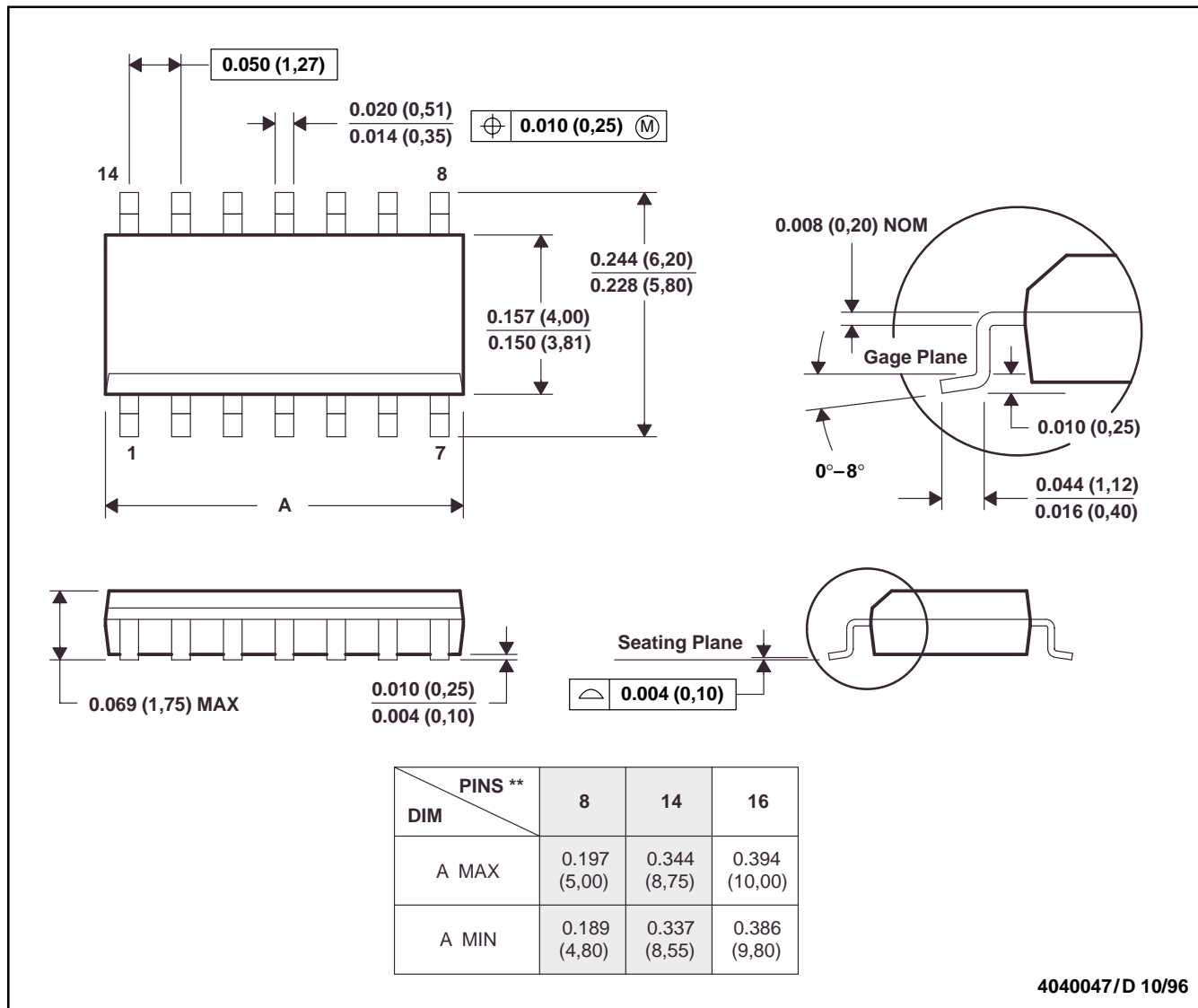

- NOTES: A. All linear dimensions are in inches (millimeters).  
 B. This drawing is subject to change without notice.  
 C. Body dimensions do not include mold flash or protrusion, not to exceed 0.006 (0,15).  
 D. Falls within JEDEC MS-012

# SN65LVDS047 LVDS QUAD DIFFERENTIAL LINE DRIVER

SLLS416A – JUNE 2000 – REVISED MAY 2001

## MECHANICAL DATA

PW (R-PDSO-G\*\*)

PLASTIC SMALL-OUTLINE PACKAGE

14 PINS SHOWN

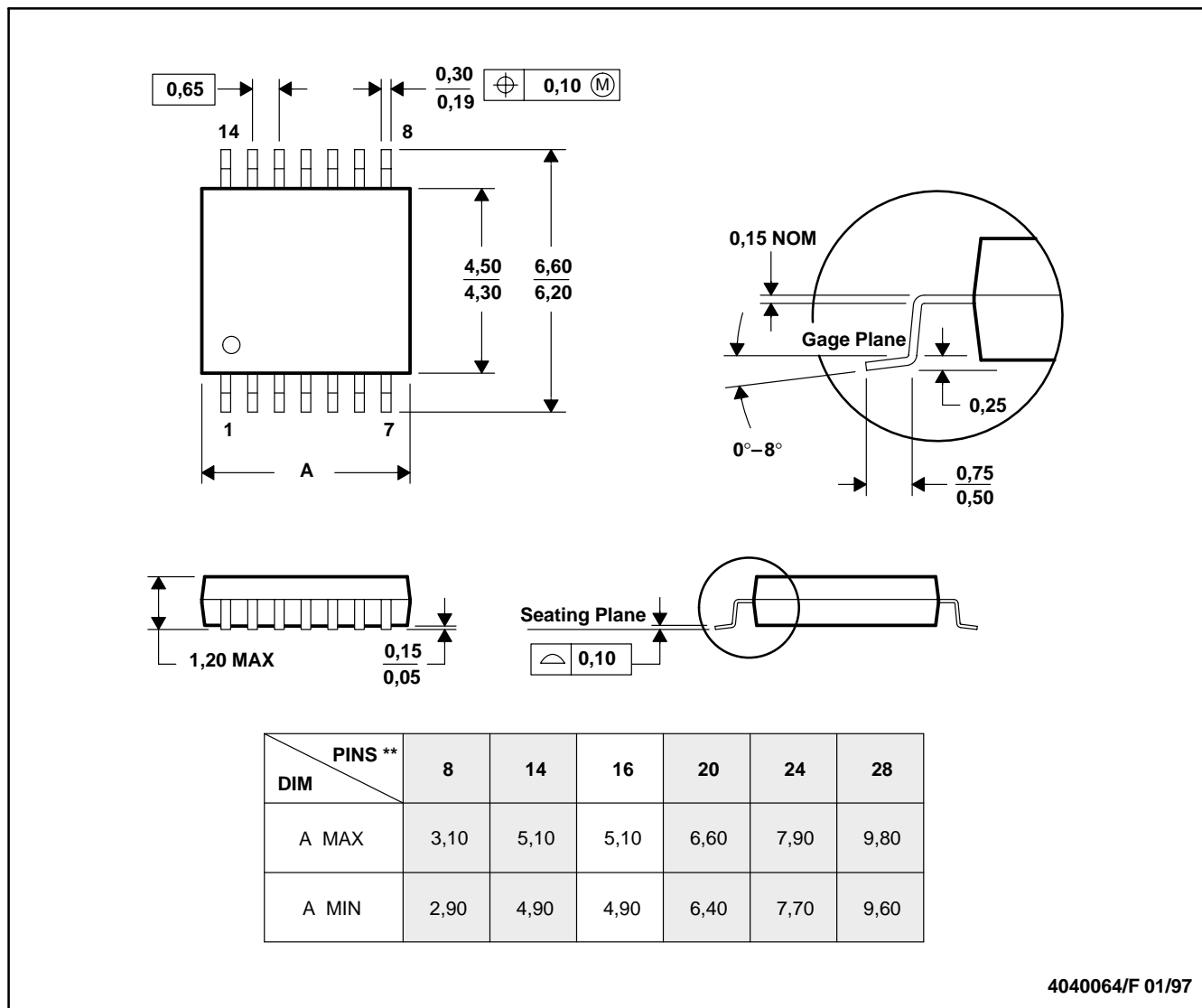

4040064/F 01/97

- NOTES: A. All linear dimensions are in millimeters.  
 B. This drawing is subject to change without notice.  
 C. Body dimensions do not include mold flash or protrusion not to exceed 0,15.  
 D. Falls within JEDEC MO-153

## IMPORTANT NOTICE

Texas Instruments Incorporated and its subsidiaries (TI) reserve the right to make corrections, modifications, enhancements, improvements, and other changes to its products and services at any time and to discontinue any product or service without notice. Customers should obtain the latest relevant information before placing orders and should verify that such information is current and complete. All products are sold subject to TI's terms and conditions of sale supplied at the time of order acknowledgment.

TI warrants performance of its hardware products to the specifications applicable at the time of sale in accordance with TI's standard warranty. Testing and other quality control techniques are used to the extent TI deems necessary to support this warranty. Except where mandated by government requirements, testing of all parameters of each product is not necessarily performed.

TI assumes no liability for applications assistance or customer product design. Customers are responsible for their products and applications using TI components. To minimize the risks associated with customer products and applications, customers should provide adequate design and operating safeguards.

TI does not warrant or represent that any license, either express or implied, is granted under any TI patent right, copyright, mask work right, or other TI intellectual property right relating to any combination, machine, or process in which TI products or services are used. Information published by TI regarding third-party products or services does not constitute a license from TI to use such products or services or a warranty or endorsement thereof. Use of such information may require a license from a third party under the patents or other intellectual property of the third party, or a license from TI under the patents or other intellectual property of TI.

Reproduction of information in TI data books or data sheets is permissible only if reproduction is without alteration and is accompanied by all associated warranties, conditions, limitations, and notices. Reproduction of this information with alteration is an unfair and deceptive business practice. TI is not responsible or liable for such altered documentation.

Resale of TI products or services with statements different from or beyond the parameters stated by TI for that product or service voids all express and any implied warranties for the associated TI product or service and is an unfair and deceptive business practice. TI is not responsible or liable for any such statements.

### Mailing Address:

Texas Instruments  
Post Office Box 655303  
Dallas, Texas 75265