

SN65LVDS048A LVDS QUAD DIFFERENTIAL LINE RECEIVER

SLLS451B– SEPTEMBER 2000 – REVISED SEPTEMBER 2002

- >400 Mbps (200 MHz) Signaling Rates
- Flow-Through Pinout Simplifies PCB Layout
- 50 ps Channel-to-Channel Skew (Typ)
- 200 ps Differential Skew (Typ)
- Propagation Delay Times 2.7 ns (Typ)
- 3.3-V Power Supply Design
- High Impedance LVDS Inputs on Power Down
- Low-Power Dissipation (40 mW at 3.3 V Static)
- Accepts Small Swing (350 mV) Differential Signal Levels
- Supports Open, Short, and Terminated Input Fail-Safe
- Industrial Operating Temperature Range (–40°C to 85°C)
- Conforms to TIA/EIA-644 LVDS Standard
- Available in SOIC and TSSOP Packages
- Pin-Compatible With DS90LV048A From National

description

The SN65LVDS048A is a quad differential line receiver that implements the electrical characteristics of low-voltage differential signaling (LVDS). This signaling technique lowers the output voltage levels of 5-V differential standard levels (such as EIA/TIA-422B) to reduce the power, increase the switching speeds, and allow operation with a 3.3-V supply rail. Any of the quad differential receivers will provide a valid logical output state with a ± 100 -mV differential input voltage within the input common-mode voltage range. The input common-mode voltage range allows 1 V of ground potential difference between two LVDS nodes.

The intended application of this device and signaling technique is for point-to-point baseband data transmission over controlled impedance media of approximately 100 Ω . The transmission media may be printed-circuit board traces, backplanes, or cables. The ultimate rate and distance of data transfer is dependent upon the attenuation characteristics of the media, the noise coupling to the environment, and other system characteristics.

The SN65LVDS048A is characterized for operation from –40°C to 85°C.

SN65LVDS048AD (Marked as LVDS048A)
SN65LVDS048APW (Marked as DL048A)

(TOP VIEW)

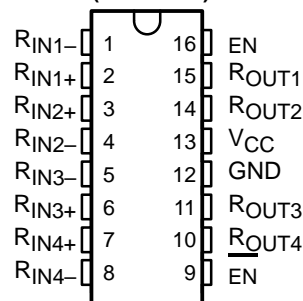

functional diagram

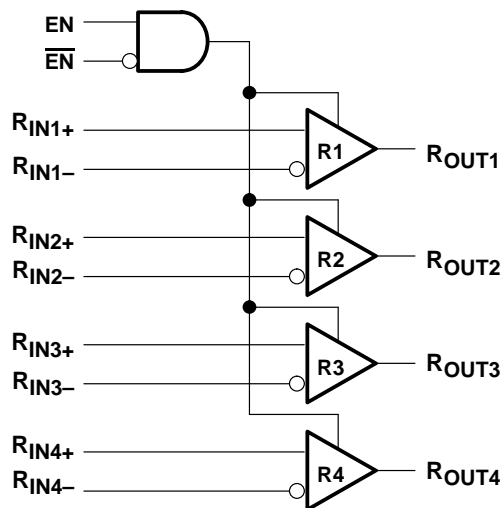

Please be aware that an important notice concerning availability, standard warranty, and use in critical applications of Texas Instruments semiconductor products and disclaimers thereto appears at the end of this data sheet.

PRODUCTION DATA information is current as of publication date. Products conform to specifications per the terms of Texas Instruments standard warranty. Production processing does not necessarily include testing of all parameters.

 **TEXAS
INSTRUMENTS**

POST OFFICE BOX 655303 • DALLAS, TEXAS 75265

Copyright © 2002, Texas Instruments Incorporated

SN65LVDS048A

LVDS QUAD DIFFERENTIAL LINE RECEIVER

SLLS451B– SEPTEMBER 2000 – REVISED SEPTEMBER 2002

TRUTH TABLE

DIFFERENTIAL INPUT	ENABLES		OUTPUT
	EN	$\overline{\text{EN}}$	
$R_{\text{IN}+} - R_{\text{IN}-}$	H	L or OPEN	R_{OUT}
$V_{\text{ID}} \geq 100 \text{ mV}$			H
$V_{\text{ID}} \leq -100 \text{ mV}$			L
Open/short or terminated	All other conditions		H
X	All other conditions		Z

H = high level, L = low level, X = irrelevant, Z = high impedance (off)

equivalent input and output schematic diagrams

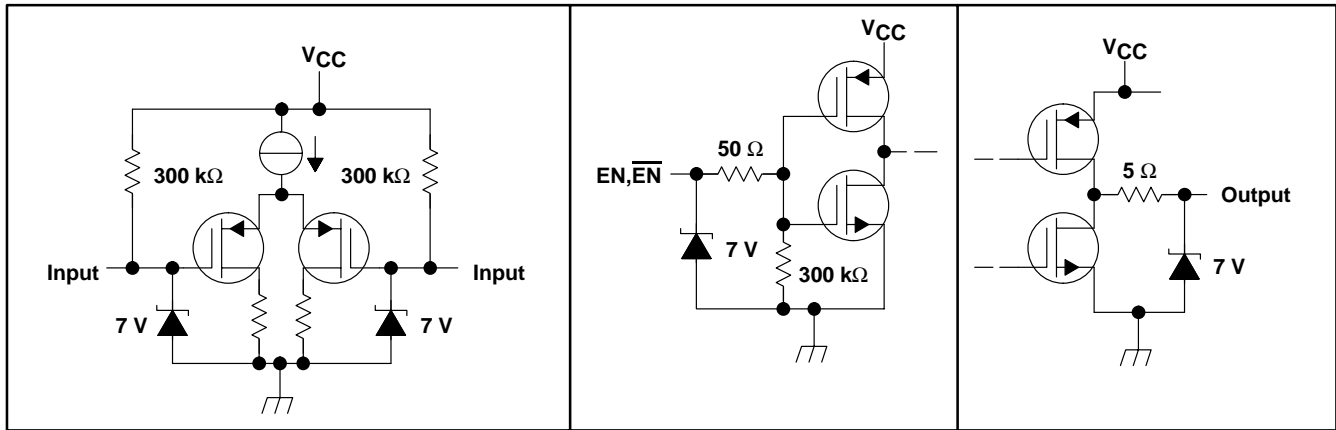

absolute maximum ratings over operating free-air temperature (unless otherwise noted)†

Supply voltage range (V_{CC})	–0.3 V to 4 V
Input voltage range, $V_{\text{I}}(R_{\text{IN}+}, R_{\text{IN}-})$	–0.3 V to 4 V
Enable input voltage ($\text{EN}, \overline{\text{EN}}$)	–0.3 V to ($V_{\text{CC}} + 0.3 \text{ V}$)
Output voltage, $V_{\text{O}}(R_{\text{OUT}})$	–0.3 V to ($V_{\text{CC}} + 0.3 \text{ V}$)
Bus-pin ($R_{\text{IN}+}, R_{\text{IN}-}$) Electrostatic discharge (see Note 2)	> 10 kV
Continuous power dissipation	See Dissipation Rating Table
Storage temperature range	–65°C to 150°C
Lead temperature 1,6 mm (1/16 inch) from case for 10 seconds	260°C

† Stresses beyond those listed under “absolute maximum ratings” may cause permanent damage to the device. These are stress ratings only, and functional operation of the device at these or any other conditions beyond those indicated under “recommended operating conditions” is not implied. Exposure to absolute-maximum-rated conditions for extended periods may affect device reliability.

- NOTES: 1. All voltage values, except differential I/O bus voltages, are with respect to network ground terminal.
2. Tested in accordance with MIL-STD-883C Method 3015.7.

DISSIPATION RATING TABLE

PACKAGE	$T_{\text{A}} \leq 25^{\circ}\text{C}$ POWER RATING	OPERATING FACTOR‡ ABOVE $T_{\text{A}} = 25^{\circ}\text{C}$	$T_{\text{A}} = 85^{\circ}\text{C}$ POWER RATING
D	950 mW	7.6 mW/°C	494 mW
PW	774 mW	6.2 mW/°C	402 mW

‡ This is the inverse of the junction-to-ambient thermal resistance when board-mounted and with no air flow.

SN65LVDS048A

LVDS QUAD DIFFERENTIAL LINE RECEIVER

SLLS451B– SEPTEMBER 2000 – REVISED SEPTEMBER 2002

recommended operating conditions

	MIN	NOM	MAX	UNIT
Supply voltage, V_{CC}	3	3.3	3.6	V
Receiver input voltage	GND		3	V
Common-mode input voltage, V_{IC}	$\frac{ V_{ID} }{2}$		$2.4 - \frac{ V_{ID} }{2}$	V
			$V_{CC} - 0.8$	
Operating free-air temperature, T_A	-40	25	85	°C

electrical characteristics over recommended operating free-air temperature range (unless otherwise noted) (see Note 3)

PARAMETER	TEST CONDITIONS	MIN	TYP†	MAX	UNIT	
V_{IT+} Differential input high threshold voltage	$V_{CM} = 1.2\text{ V}, 0.05\text{ V}, 2.35\text{ V}$ (see Note 4)	100			mV	
V_{IT-} Differential input low threshold voltage		-100				
$V_{(CMR)}$ Common mode voltage range	$V_{ID} = 200\text{ mV pk to pk}$ (see Note 5)	0.1		2.3	V	
I_{IN} Input current	$V_{IN} = 2.8\text{ V}$	$V_{CC} = 3.6\text{ V or }0\text{ V}$	-20	±1	20	μA
	$V_{IN} = 0\text{ V}$		-20	±1	20	μA
	$V_{IN} = 3.6\text{ V}$		$V_{CC} = 0\text{ V}$	-20	±1	20
V_{OH} Output high voltage	$I_{OH} = -0.4\text{ mA}, V_{ID} = 200\text{ mV}$	2.7	3.2		V	
	$I_{OH} = -0.4\text{ mA},$ input terminated	2.7	3.2		V	
	$I_{OH} = -0.4\text{ mA},$ input shorted	2.7	3.2		V	
V_{OL} Output low voltage	$I_{OL} = 2\text{ mA}, V_{ID} = -200\text{ mV}$		0.05	0.25	V	
I_{OS} Output short circuit current	Enabled, $V_{OUT} = 0\text{ V}$ (see Note 6)		-65	-100	mA	
$I_{O(Z)}$ Output 3-state current	Disabled, $V_{OUT} = 0\text{ V or }V_{CC}$	-1		1	μA	
V_{IH} Input high voltage		2.0		V_{CC}	V	
V_{IL} Input low voltage		GND		0.8	V	
I_I Input current (enables)	$V_{IN} = 0\text{ V or }V_{CC},$ Other input = V_{CC} or GND	-10		10	μA	
V_{IK} Input clamp voltage	$I_{CL} = -18\text{ mA}$	-1.5	-0.8		V	
I_{CC} No load supply current, receivers enabled	$EN = V_{CC},$ Inputs open		8	15	mA	
$I_{CC(Z)}$ No load supply current, receivers disabled	$EN = GND,$ Inputs open		0.6	1.5	mA	

† All typical values are at 25°C and with a 3.3-V supply.

- NOTES:
- Current into device pin is defined as positive. Current out of the device is defined as negative. All voltages are referenced to ground, unless otherwise specified.
 - V_{CC} is always higher than R_{IN+} and R_{IN-} voltage, R_{IN-} and R_{IN+} have a voltage range of $-0.2\text{ V to }V_{CC}-V_{ID}/2$. To be compliant with ac specifications the common voltage range is 0.1 V to 2.3 V.
 - The VCMR range is reduced for larger V_{ID} . Example: If $V_{ID} = 400\text{ mV}$, the VCMR is 0.2 V to 2.2 V. The fail-safe condition with inputs shorted is not supported over the common-mode range of 0 V to 2.4 V, but is supported only with inputs shorted and no external common-mode voltage applied. A V_{ID} up to $V_{CC}-0\text{ V}$ may be applied to the R_{IN+} and R_{IN-} inputs with the common-mode voltage set to $V_{CC}/2$. Propagation delay and differential pulse skew decrease when V_{ID} is increased from 200 mV to 400 mV. Skew specifications apply for $200\text{ mV} < V_{ID} < 800\text{ mV}$ over the common-mode range.
 - Output short circuit current (I_{OS}) is specified as magnitude only, minus sign indicates direction only. Only one output should be shorted at a time. Do not exceed maximum junction temperature specification.



SN65LVDS048A

LVDS QUAD DIFFERENTIAL LINE RECEIVER

SLLS451B– SEPTEMBER 2000 – REVISED SEPTEMBER 2002

switching characteristics over recommended operating conditions (unless otherwise noted) (see Notes 7)

PARAMETER		TEST CONDITIONS	MIN	TYP†	MAX	UNIT
t _{PHL}	Differential propagation delay, high-to-low	C _L = 15 pF V _{ID} = 200 mV (see Figure 1 and 2)	1.9	2.7	3.7	ns
t _{PLH}	Differential propagation delay, low-to-high		1.9	2.9	3.7	ns
t _{SK(p)}	Differential pulse skew (t _{PHLD} – t _{PLHD}) (see Note 8)		200	450		ps
t _{SK(o)}	Differential channel-to-channel skew; same device (see Note 8)		50	500		ps
t _{SK(pp)}	Differential part-to-part skew (see Note 10)				1	ns
t _{SK(lim)}	Differential part-to-part skew (see Note 11)				1.5	ns
t _r	Rise time		0.5	1		ns
t _f	Fall time		0.5	1		ns
t _{PHZ}	Disable time high to Z	R _L = 2 K Ω C _L = 15 pF (see Figure 3 and 4)		8	9	ns
t _{PLZ}	Disable time low to Z			6	8	ns
t _{PZH}	Enable time Z to high			8	10	ns
t _{PZL}	Enable time Z to low			7	8	ns
f _(MAX)	Maximum operating frequency (see Note 12)	All channels switching	200	250		MHz

† All typical values are at 25°C and with a 3.3-V supply.

- NOTES:
- Generator waveform for all tests unless otherwise specified: f = 1 MHz, Z_O = 50 Ω, t_r and t_f (0% – 100%) ≤ 3 ns for R_{IN}.
 - t_{SK(p)}|t_{PLH} – t_{PHL}| is the magnitude difference in differential propagation delay time between the positive going edge and the negative going edge of the same channel.
 - t_{SK(o)} is the differential channel-to-channel skew of any event on the same device.
 - t_{SK(pp)} is the differential part-to-part skew, and is defined as the difference between the minimum and the maximum specified differential propagation delays. This specification applies to devices at the same VCC and within 5°C of each other within the operating temperature range.
 - t_{sk(lim)} part-to-part skew, is the differential channel-to-channel skew of any event between devices. This specification applies to devices over recommended operating temperature and voltage ranges, and across process distribution. t_{sk(lim)} is defined as |Min – Max| differential propagation delay.
 - f_(MAX) generator input conditions: t_r = t_f < 1 ns (0% to 100%), 50% duty cycle, 0 V to 3 V. Output criteria: duty cycle = 45% to 55%, V_{OD} > 250 mV, all channels switching



PARAMETER MEASUREMENT INFORMATION

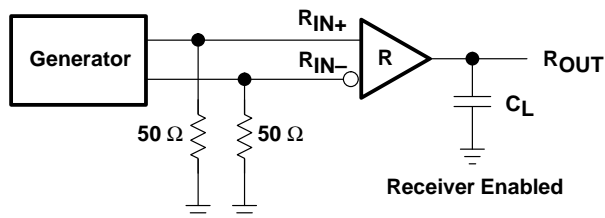

Figure 1. Receiver Propagation Delay and Transition Time Test Circuit

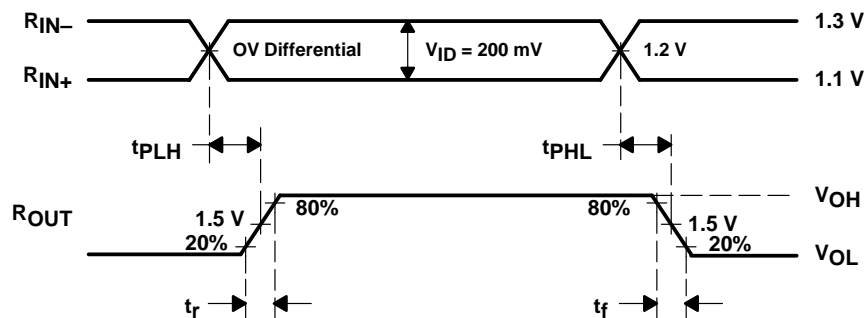
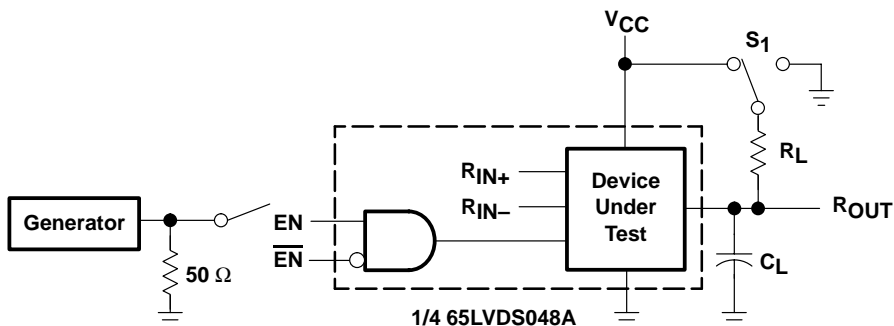

Figure 2. Receiver Propagation Delay and Transition Time Waveforms

SN65LVDS048A LVDS QUAD DIFFERENTIAL LINE RECEIVER

SLLS451B- SEPTEMBER 2000 – REVISED SEPTEMBER 2002

PARAMETER MEASUREMENT INFORMATION



C_L Includes Load and Test Jig Capacitance.
 $S_1 = V_{CC}$ for t_{pZL} and t_{pLZ} Measurements.
 $S_1 = GND$ for t_{pZH} and t_{pHZ} Measurements.

Figure 3. Receiver 3-State Delay Test Circuit

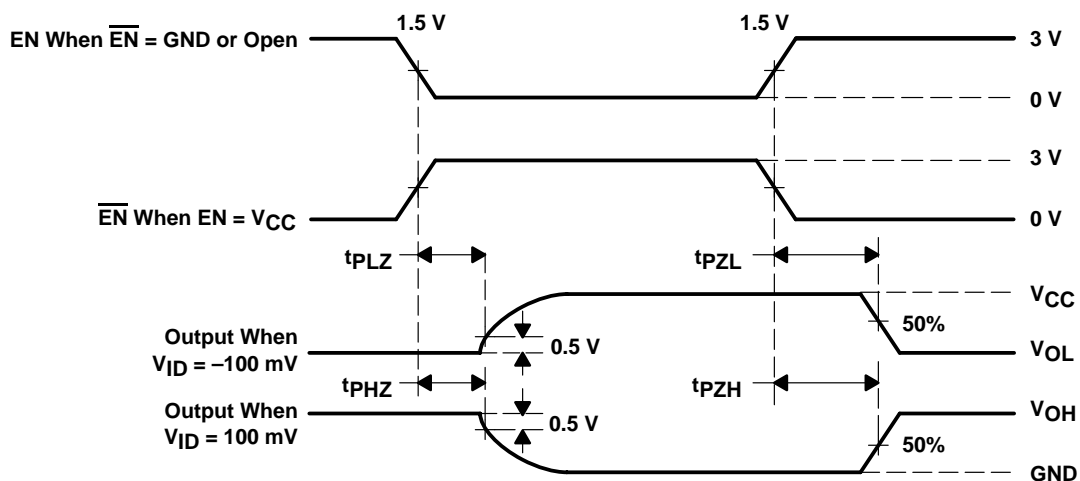

Figure 4. Receiver 3-State Delay Waveforms

TYPICAL CHARACTERISTICS

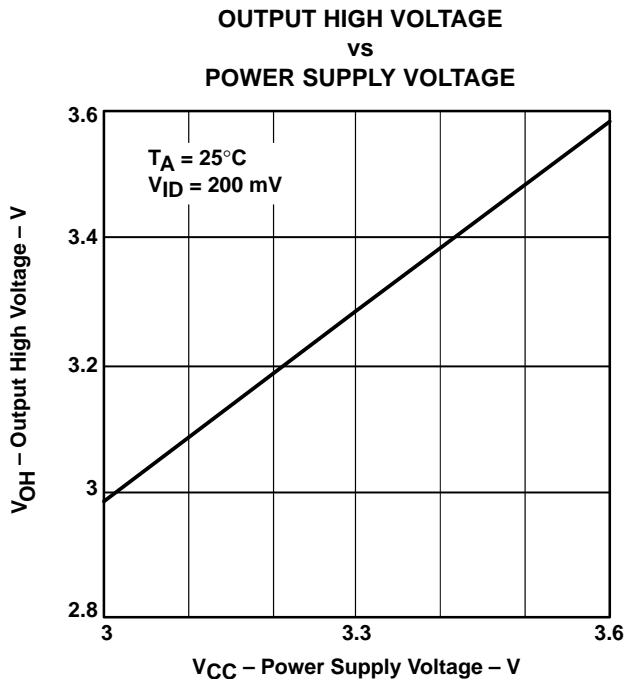

Figure 5

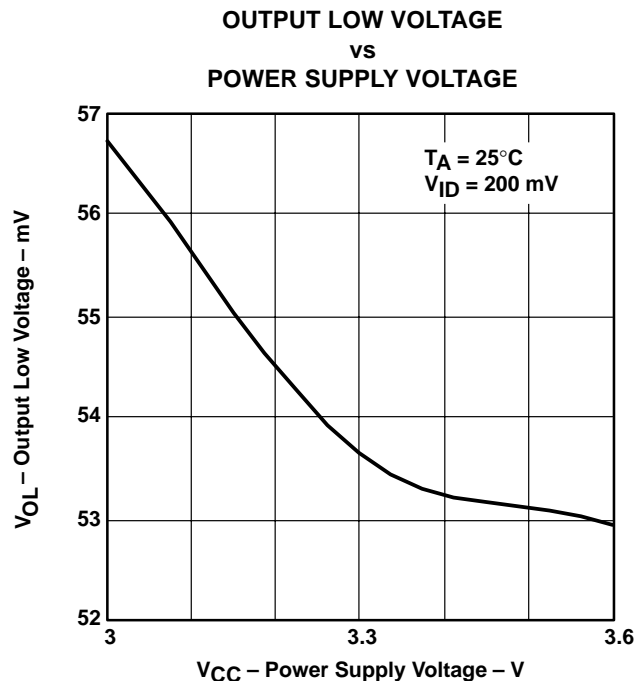

Figure 6

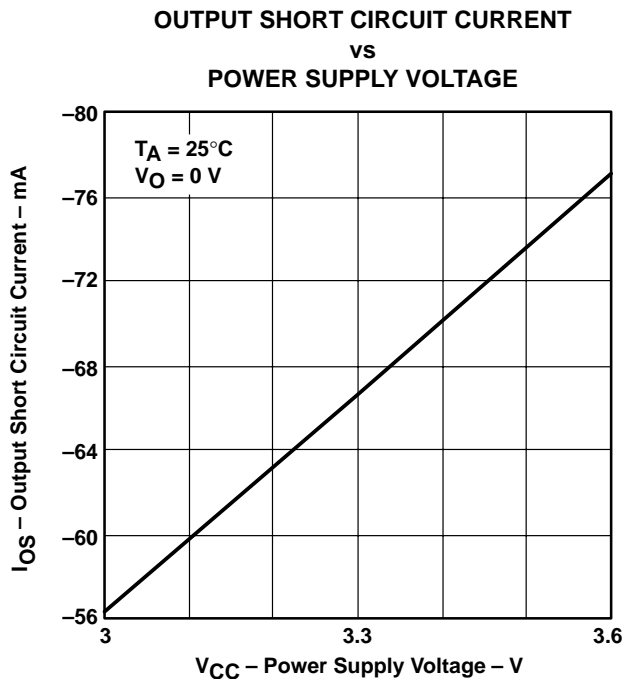

Figure 7

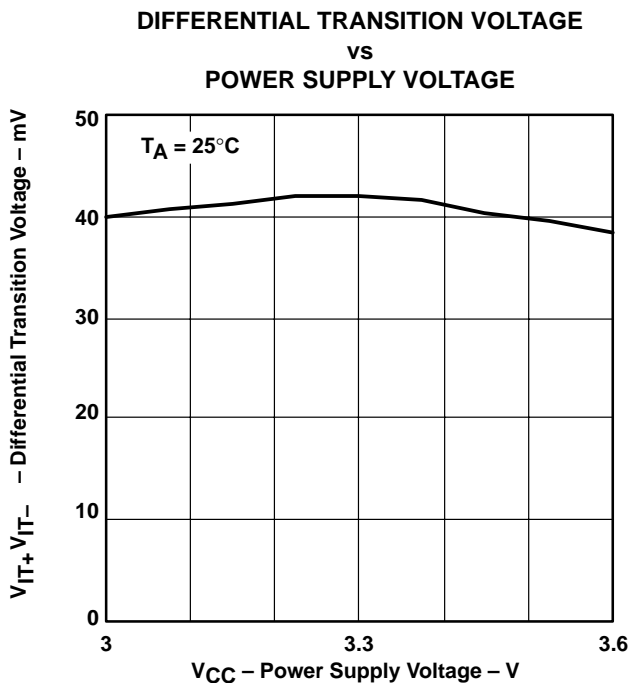
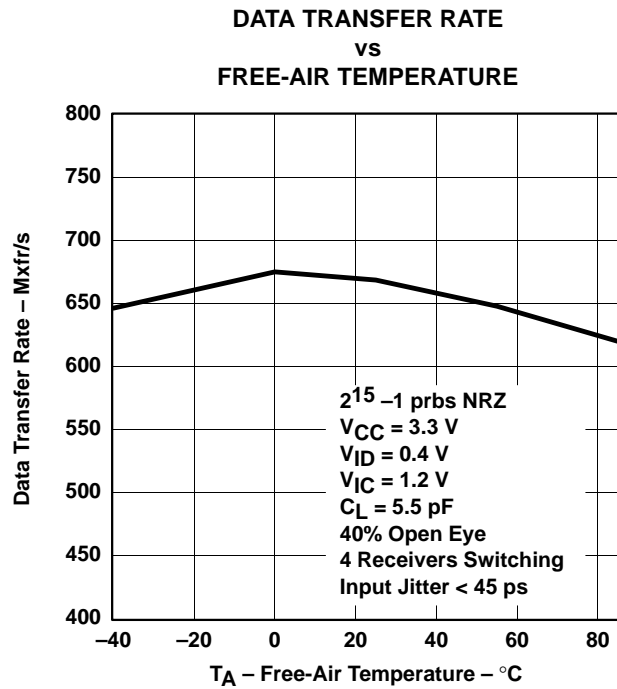
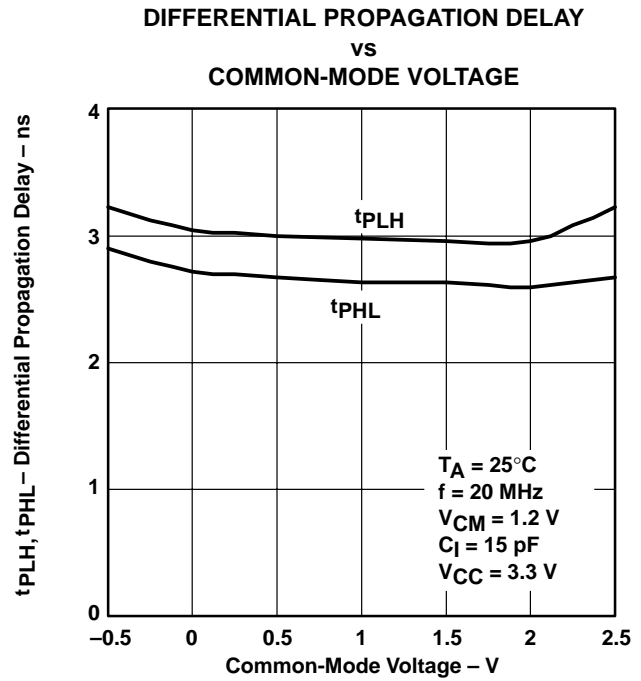
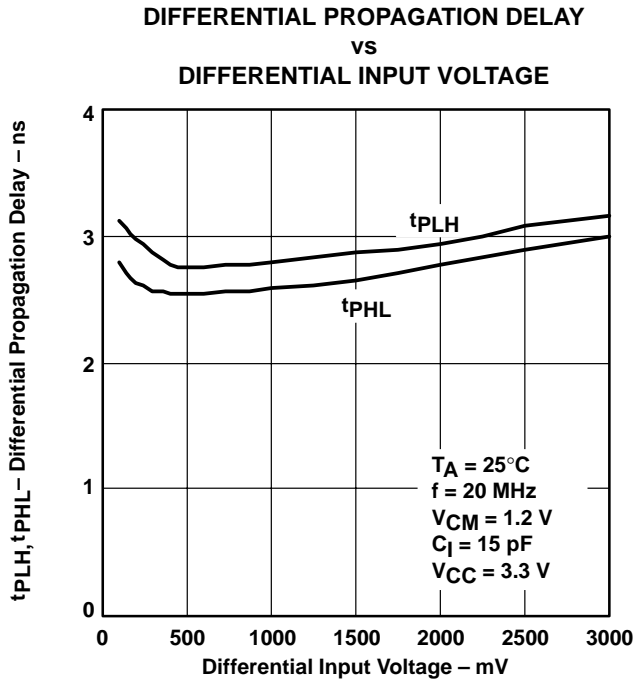

Figure 8

SN65LVDS048A LVDS QUAD DIFFERENTIAL LINE RECEIVER

SLLS451B- SEPTEMBER 2000 - REVISED SEPTEMBER 2002

TYPICAL CHARACTERISTICS



APPLICATION INFORMATION

fail safe

One of the most common problems with differential signaling applications is how the system responds when no differential voltage is present on the signal pair. The LVDS receiver is like most differential line receivers, in that its output logic state can be indeterminate when the differential input voltage is between -100 mV and 100 mV and within its recommended input common-mode voltage range. TI's LVDS receiver is different in how it handles the open-input circuit situation, however.

Open-circuit means that there is little or no input current to the receiver from the data line itself. This could be when the driver is in a high-impedance state or the cable is disconnected. When this occurs, the LVDS receiver will pull each line of the signal pair to near V_{CC} through $300\text{-k}\Omega$ resistors as shown in Figure 10. The fail-safe feature uses an AND gate with input voltage thresholds at about 2.3 V to detect this condition and force the output to a high-level regardless of the differential input voltage.

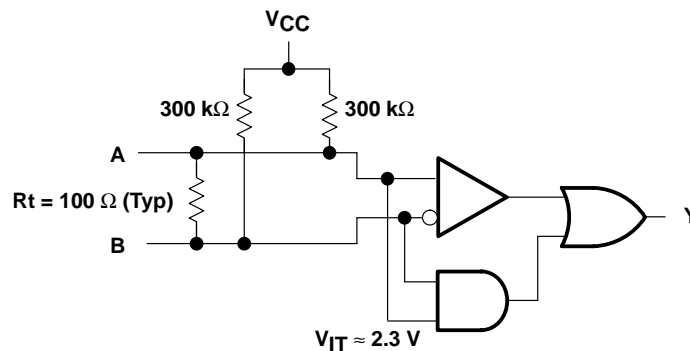

Figure 12. Open-Circuit Fail Safe of the LVDS Receiver

It is only under these conditions that the output of the receiver will be valid with less than a 100-mV differential input voltage magnitude. The presence of the termination resistor, R_t , does not affect the fail-safe function as long as it is connected as shown in the figure. Other termination circuits may allow a dc current to ground that could defeat the pullup currents from the receiver and the fail-safe feature.

SN65LVDS048A LVDS QUAD DIFFERENTIAL LINE RECEIVER

SLLS451B- SEPTEMBER 2000 - REVISED SEPTEMBER 2002

MECHANICAL DATA

D (R-PDSO-G**)

PLASTIC SMALL-OUTLINE PACKAGE

14 PINS SHOWN

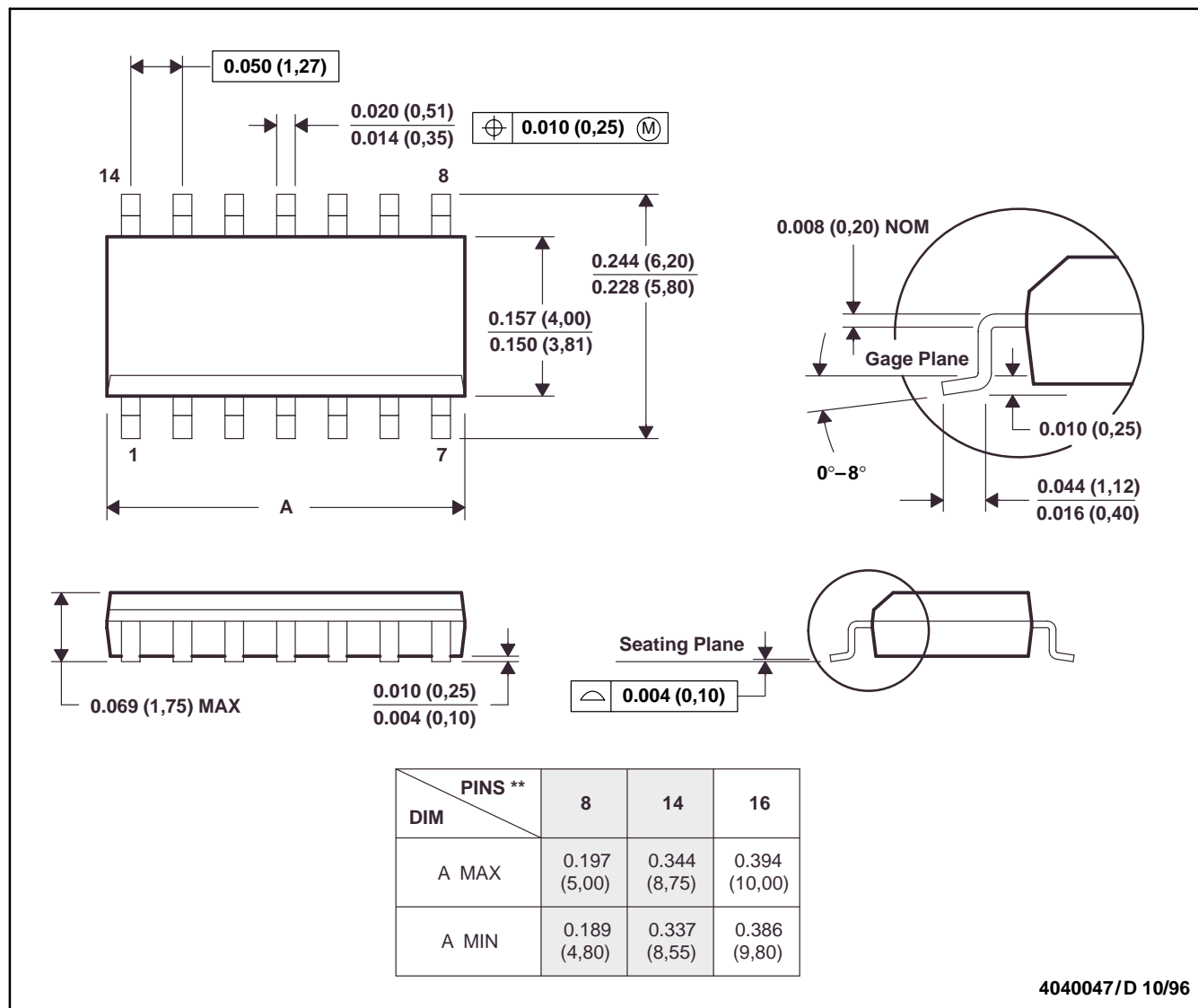

- NOTES: A. All linear dimensions are in inches (millimeters).
 B. This drawing is subject to change without notice.
 C. Body dimensions do not include mold flash or protrusion, not to exceed 0.006 (0,15).
 D. Falls within JEDEC MS-012

SN65LVDS048A LVDS QUAD DIFFERENTIAL LINE RECEIVER

SLLS451B– SEPTEMBER 2000 – REVISED SEPTEMBER 2002

MECHANICAL DATA

PW (R-PDSO-G)**

PLASTIC SMALL-OUTLINE PACKAGE

14 PINS SHOWN

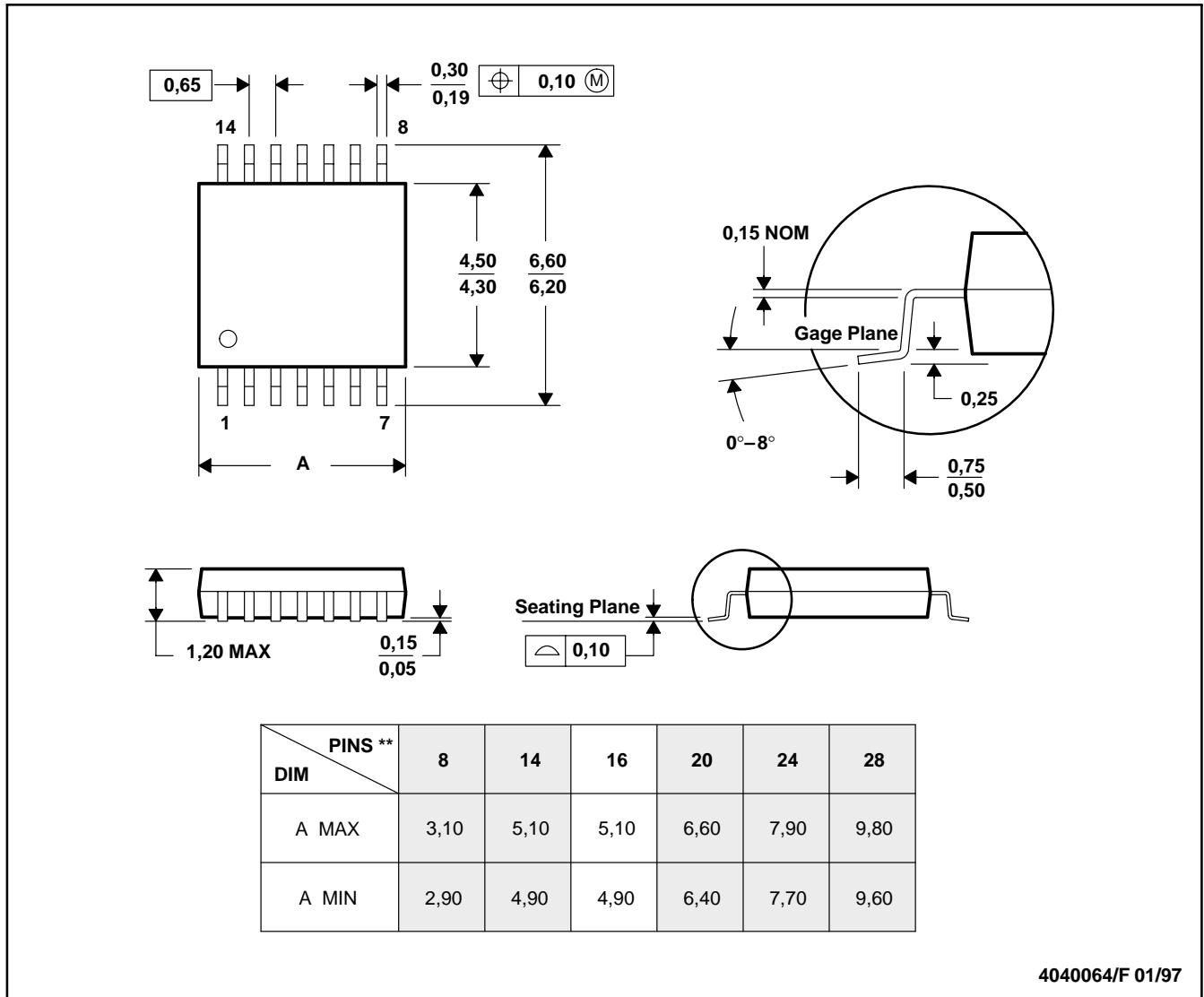

- NOTES: A. All linear dimensions are in millimeters.
 B. This drawing is subject to change without notice.
 C. Body dimensions do not include mold flash or protrusion not to exceed 0,15.
 D. Falls within JEDEC MO-153

PACKAGING INFORMATION

Orderable Device	Status ⁽¹⁾	Package Type	Package Drawing	Pins	Package Qty	Eco Plan ⁽²⁾	Lead/Ball Finish	MSL Peak Temp ⁽³⁾
SN65LVDS048AD	ACTIVE	SOIC	D	16	40	Pb-Free (RoHS)	CU NIPDAU	Level-2-260C-1YEAR/ Level-1-220C-UNLIM
SN65LVDS048ADR	ACTIVE	SOIC	D	16	2500	Pb-Free (RoHS)	CU NIPDAU	Level-2-260C-1YEAR/ Level-1-220C-UNLIM
SN65LVDS048APW	ACTIVE	TSSOP	PW	16	90	None	CU NIPDAU	Level-1-220C-UNLIM
SN65LVDS048APWR	ACTIVE	TSSOP	PW	16	2000	None	CU NIPDAU	Level-1-220C-UNLIM

⁽¹⁾ The marketing status values are defined as follows:

ACTIVE: Product device recommended for new designs.

LIFEBUY: TI has announced that the device will be discontinued, and a lifetime-buy period is in effect.

NRND: Not recommended for new designs. Device is in production to support existing customers, but TI does not recommend using this part in a new design.

PREVIEW: Device has been announced but is not in production. Samples may or may not be available.

OBSOLETE: TI has discontinued the production of the device.

⁽²⁾ Eco Plan - May not be currently available - please check <http://www.ti.com/productcontent> for the latest availability information and additional product content details.

None: Not yet available Lead (Pb-Free).

Pb-Free (RoHS): TI's terms "Lead-Free" or "Pb-Free" mean semiconductor products that are compatible with the current RoHS requirements for all 6 substances, including the requirement that lead not exceed 0.1% by weight in homogeneous materials. Where designed to be soldered at high temperatures, TI Pb-Free products are suitable for use in specified lead-free processes.

Green (RoHS & no Sb/Br): TI defines "Green" to mean "Pb-Free" and in addition, uses package materials that do not contain halogens, including bromine (Br) or antimony (Sb) above 0.1% of total product weight.

⁽³⁾ MSL, Peak Temp. -- The Moisture Sensitivity Level rating according to the JEDEC industry standard classifications, and peak solder temperature.

Important Information and Disclaimer:The information provided on this page represents TI's knowledge and belief as of the date that it is provided. TI bases its knowledge and belief on information provided by third parties, and makes no representation or warranty as to the accuracy of such information. Efforts are underway to better integrate information from third parties. TI has taken and continues to take reasonable steps to provide representative and accurate information but may not have conducted destructive testing or chemical analysis on incoming materials and chemicals. TI and TI suppliers consider certain information to be proprietary, and thus CAS numbers and other limited information may not be available for release.

In no event shall TI's liability arising out of such information exceed the total purchase price of the TI part(s) at issue in this document sold by TI to Customer on an annual basis.

IMPORTANT NOTICE

Texas Instruments Incorporated and its subsidiaries (TI) reserve the right to make corrections, modifications, enhancements, improvements, and other changes to its products and services at any time and to discontinue any product or service without notice. Customers should obtain the latest relevant information before placing orders and should verify that such information is current and complete. All products are sold subject to TI's terms and conditions of sale supplied at the time of order acknowledgment.

TI warrants performance of its hardware products to the specifications applicable at the time of sale in accordance with TI's standard warranty. Testing and other quality control techniques are used to the extent TI deems necessary to support this warranty. Except where mandated by government requirements, testing of all parameters of each product is not necessarily performed.

TI assumes no liability for applications assistance or customer product design. Customers are responsible for their products and applications using TI components. To minimize the risks associated with customer products and applications, customers should provide adequate design and operating safeguards.

TI does not warrant or represent that any license, either express or implied, is granted under any TI patent right, copyright, mask work right, or other TI intellectual property right relating to any combination, machine, or process in which TI products or services are used. Information published by TI regarding third-party products or services does not constitute a license from TI to use such products or services or a warranty or endorsement thereof. Use of such information may require a license from a third party under the patents or other intellectual property of the third party, or a license from TI under the patents or other intellectual property of TI.

Reproduction of information in TI data books or data sheets is permissible only if reproduction is without alteration and is accompanied by all associated warranties, conditions, limitations, and notices. Reproduction of this information with alteration is an unfair and deceptive business practice. TI is not responsible or liable for such altered documentation.

Resale of TI products or services with statements different from or beyond the parameters stated by TI for that product or service voids all express and any implied warranties for the associated TI product or service and is an unfair and deceptive business practice. TI is not responsible or liable for any such statements.

Following are URLs where you can obtain information on other Texas Instruments products and application solutions:

Products		Applications	
Amplifiers	amplifier.ti.com	Audio	www.ti.com/audio
Data Converters	dataconverter.ti.com	Automotive	www.ti.com/automotive
DSP	dsp.ti.com	Broadband	www.ti.com/broadband
Interface	interface.ti.com	Digital Control	www.ti.com/digitalcontrol
Logic	logic.ti.com	Military	www.ti.com/military
Power Mgmt	power.ti.com	Optical Networking	www.ti.com/opticalnetwork
Microcontrollers	microcontroller.ti.com	Security	www.ti.com/security
		Telephony	www.ti.com/telephony
		Video & Imaging	www.ti.com/video
		Wireless	www.ti.com/wireless

Mailing Address: Texas Instruments
Post Office Box 655303 Dallas, Texas 75265