

SN65LVDS179, SN65LVDS180, SN65LVDS050, SN65LVDS051 HIGH-SPEED DIFFERENTIAL LINE DRIVERS AND RECEIVERS

SLLS301K – APRIL 1998 – REVISED JANUARY 2003

- Meets or Exceeds the Requirements of ANSI TIA/EIA-644-1995 Standard
- Signaling Rates up to 400 Mbps
- Bus-Terminal ESD Exceeds 12 kV
- Operates From a Single 3.3-V Supply
- Low-Voltage Differential Signaling With Typical Output Voltages of 350 mV and a 100-Ω Load
- Propagation Delay Times
 - Driver: 1.7 ns Typ
 - Receiver: 3.7 ns Typ
- Power Dissipation at 200 MHz
 - Driver: 25 mW Typical
 - Receiver: 60 mW Typical
- LVTTTL Input Levels Are 5-V Tolerant
- Receiver Maintains High Input Impedance With $V_{CC} < 1.5$ V
- Receiver Has Open-Circuit Fail Safe

description

The SN65LVDS179, SN65LVDS180, SN65LVDS050, and SN65LVDS051 are differential line drivers and receivers that use low-voltage differential signaling (LVDS) to achieve signaling rates as high as 400 Mbps. The TIA/EIA-644 standard compliant electrical interface provides a minimum differential output voltage magnitude of 247 mV into a 100-Ω load and receipt of 50-mV signals with up to 1 V of ground potential difference between a transmitter and receiver.

The intended application of this device and signaling technique is for point-to-point baseband data transmission over controlled impedance media of approximately 100-Ω characteristic impedance. The transmission media may be printed-circuit board traces, backplanes, or cables. (Note: The ultimate rate and distance of data transfer is dependent upon the attenuation characteristics of the media, the noise coupling to the environment, and other application specific characteristics).

The devices offer various driver, receiver, and enabling combinations in industry standard footprints. Since these devices are intended for use in simplex or distributed simplex bus structures, the driver enable function does not put the differential outputs into a high-impedance state but rather disconnects the input and reduces the quiescent power used by the device. (For these functions with a high-impedance driver output, see the SN65LVDM series of devices.) All devices are characterized for operation from -40°C to 85°C .

SN65LVDS179D (Marked as DL179 or LVD179)
SN65LVDS179DGK (Marked as S79)
(TOP VIEW)

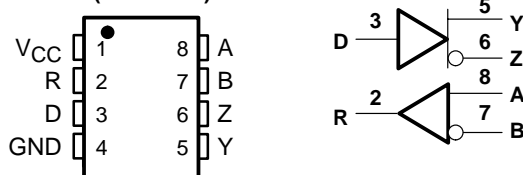

SN65LVDS180D (Marked as LVDS180)
SN65LVDS180PW (Marked as LVDS180)
(TOP VIEW)

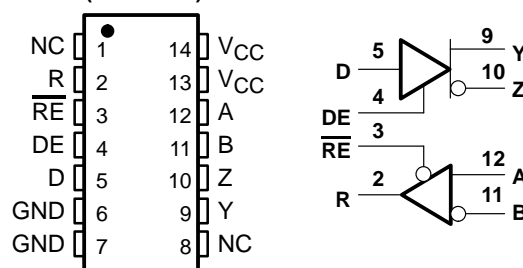

SN65LVDS050D (Marked as LVDS050)
SN65LVDS050PW (Marked as LVDS050)
(TOP VIEW)

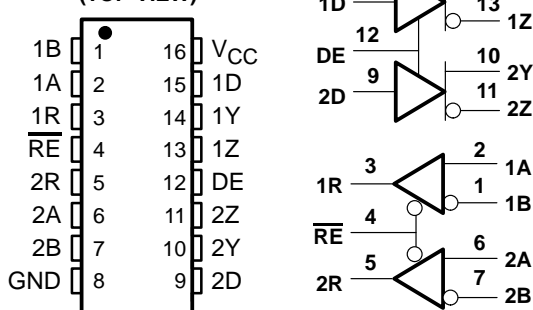

SN65LVDS051D (Marked as LVDS051)
SN65LVDS051PW (Marked as LVDS051)
(TOP VIEW)

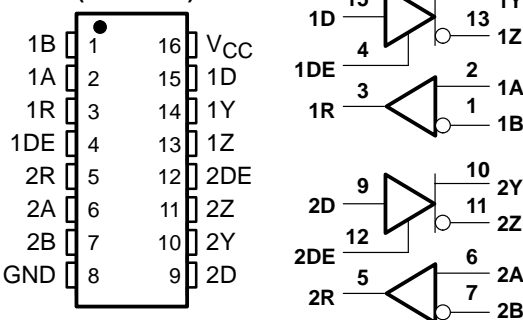

Please be aware that an important notice concerning availability, standard warranty, and use in critical applications of Texas Instruments semiconductor products and disclaimers thereto appears at the end of this data sheet.

PRODUCTION DATA information is current as of publication date. Products conform to specifications per the terms of Texas Instruments standard warranty. Production processing does not necessarily include testing of all parameters.

**TEXAS
INSTRUMENTS**

POST OFFICE BOX 655303 • DALLAS, TEXAS 75265

Copyright © 2003, Texas Instruments Incorporated

SN65LVDS179, SN65LVDS180, SN65LVDS050, SN65LVDS051 HIGH-SPEED DIFFERENTIAL LINE DRIVERS AND RECEIVERS

SLLS301K – APRIL 1998 – REVISED JANUARY 2003

AVAILABLE OPTIONS

PACKAGE		
SMALL OUTLINE (D)	SMALL OUTLINE (DGK)	SMALL OUTLINE (PW)
SN65LVDS050D	—	SN65LVDS050PW
SN65LVDS051D	—	SN65LVDS051PW
SN65LVDS179D	SN65LVDS179DGK	—
SN65LVDS180D	—	SN65LVDS180PW

Function Tables

SN65LVDS179 RECEIVER

INPUTS	OUTPUT
$V_{ID} = V_A - V_B$	R
$V_{ID} \geq 50 \text{ mV}$	H
$-50 \text{ mV} < V_{ID} < 50 \text{ mV}$?
$V_{ID} \leq -50 \text{ mV}$	L
Open	H

H = high level, L = low level, ? = indeterminate

SN65LVDS179 DRIVER

INPUT	OUTPUTS	
D	Y	Z
L	L	H
H	H	L
Open	L	H

H = high level, L = low level

SN65LVDS180, SN65LVDS050, and SN65LVDS051 RECEIVER

INPUTS		OUTPUT	
$V_{ID} = V_A - V_B$	RE	R	Z
$V_{ID} \geq 50 \text{ mV}$	L	H	
$-50 \text{ mV} < V_{ID} < 50 \text{ mV}$	L	?	
$V_{ID} \leq -50 \text{ mV}$	L	L	
Open	L	H	
X	H		Z

H = high level, L = low level, Z = high impedance,
X = don't care

SN65LVDS180, SN65LVDS050, and SN65LVDS051 DRIVER

INPUTS		OUTPUTS	
D	DE	Y	Z
L	H	L	H
H	H	H	L
Open	H	L	H
X	L	OFF	OFF

H = high level, L = low level, OFF = No Output,
X = don't care



SN65LVDS179, SN65LVDS180, SN65LVDS050, SN65LVDS051 HIGH-SPEED DIFFERENTIAL LINE DRIVERS AND RECEIVERS

SLLS301K – APRIL 1998 – REVISED JANUARY 2003

equivalent input and output schematic diagrams

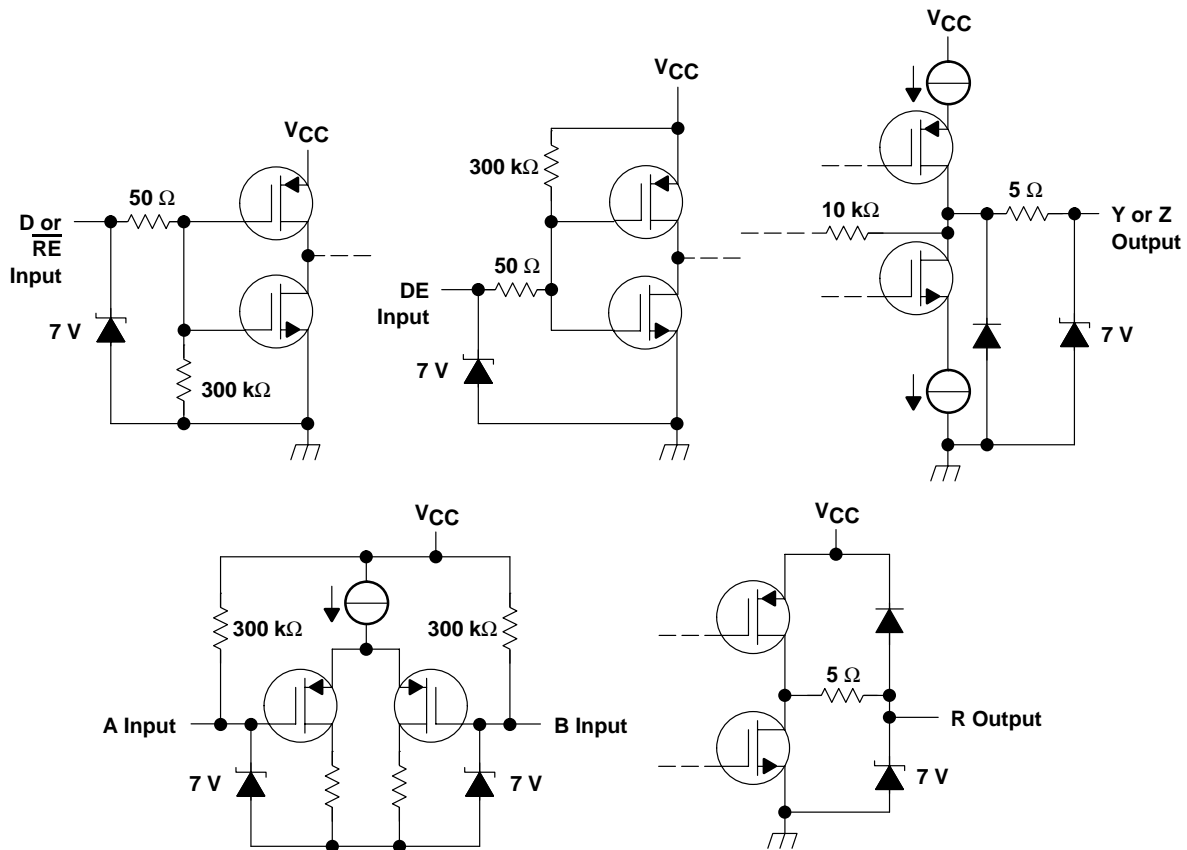

absolute maximum ratings over operating free-air temperature (unless otherwise noted)[†]

Supply voltage range, V_{CC} (see Note 1)	–0.5 V to 4 V
Voltage range: D, R, DE, \overline{RE}	–0.5 V to 6 V
Y, Z, A, and B	–0.5 V to 4 V
Electrostatic discharge: Y, Z, A, B, and GND (see Note 2)	Class 3, A:12 kV, B:600 V
All	Class 3, A:7 kV, B:500 V
Continuous power dissipation	See Dissipation Rating Table
Storage temperature range	–65°C to 150°C
Lead temperature 1,6 mm (1/16 inch) from case for 10 seconds	250°C

[†] Stresses beyond those listed under “absolute maximum ratings” may cause permanent damage to the device. These are stress ratings only, and functional operation of the device at these or any other conditions beyond those indicated under “recommended operating conditions” is not implied. Exposure to absolute-maximum-rated conditions for extended periods may affect device reliability.

- NOTES: 1. All voltage values, except differential I/O bus voltages are with respect to network ground terminal.
2. Tested in accordance with MIL-STD-883C Method 3015.7.

SN65LVDS179, SN65LVDS180, SN65LVDS050, SN65LVDS051 HIGH-SPEED DIFFERENTIAL LINE DRIVERS AND RECEIVERS

SLLS301K – APRIL 1998 – REVISED JANUARY 2003

DISSIPATION RATING TABLE

PACKAGE	T _A ≤ 25°C POWER RATING	DERATING FACTOR ABOVE T _A = 25°C†	T _A = 85°C POWER RATING
PW(14)	736 mW	5.9 mW/°C	383 mW
PW(16)	839 mW	6.7 mW/°C	437 mW
D(8)	635 mW	5.1 mW/°C	330 mW/°C
D(14)	987 mW	7.9 mW/°C	513 mW/°C
D(16)	1110 mW	8.9 mW/°C	577 mW/°C
DGK	424 mW	3.4 mW/°C	220 mW

† This is the inverse of the junction-to-ambient thermal resistance when board-mounted and with no air flow.

recommended operating conditions

	MIN	NOM	MAX	UNIT
Supply voltage, V _{CC}	3	3.3	3.6	V
High-level input voltage, V _{IH}	2			V
Low-level input voltage, V _{IL}			0.8	V
Magnitude of differential input voltage, V _{ID}	0.1		0.6	V
Magnitude of differential output voltage with disabled driver, V _{OD(dis)}			520	mV
Driver output voltage, V _{OY} or V _{OZ}	0		2.4	V
Common-mode input voltage, V _{IC} (see Figure 5)	$\frac{ V_{ID} }{2}$		$2.4 - \frac{ V_{ID} }{2}$	V
			V _{CC} -0.8	
Operating free-air temperature, T _A	-40		85	°C

device electrical characteristics over recommended operating conditions (unless otherwise noted)

PARAMETER	TEST CONDITIONS	MIN	TYP†	MAX	UNIT	
I _{CC} Supply current	SN65LVDS179	No receiver load, driver R _L = 100 Ω		9	12	mA
	SN65LVDS180	Driver and receiver enabled, no receiver load, driver R _L = 100 Ω		9	12	
		Driver enabled, receiver disabled, R _L = 100 Ω		5	7	
		Driver disabled, receiver enabled, no load		1.5	2	
		Disabled		0.5	1	
	SN65LVDS050	Drivers and receivers enabled, no receiver loads, driver R _L = 100 Ω		12	20	mA
		Drivers enabled, receivers disabled, R _L = 100 Ω		10	16	
		Drivers disabled, receivers enabled, no loads		3	6	
	SN65LVDS051	Drivers enabled, no receiver loads, driver R _L = 100 Ω		12	20	mA
		Drivers disabled, no loads		3	6	

† All typical values are at 25°C and with a 3.3-V supply.



SN65LVDS179, SN65LVDS180, SN65LVDS050, SN65LVDS051 HIGH-SPEED DIFFERENTIAL LINE DRIVERS AND RECEIVERS

SLLS301K – APRIL 1998 – REVISED JANUARY 2003

driver electrical characteristics over recommended operating conditions (unless otherwise noted)

PARAMETER		TEST CONDITIONS	MIN	TYP	MAX	UNIT
$ V_{OD} $	Differential output voltage magnitude	$R_L = 100 \Omega$, See Figures 1 and 2	247	340	454	mV
$\Delta V_{OD} $	Change in differential output voltage magnitude between logic states		-50		50	
$V_{OC(SS)}$	Steady-state common-mode output voltage	See Figure 3	1.125	1.2	1.375	V
$\Delta V_{OC(SS)}$	Change in steady-state common-mode output voltage between logic states		-50		50	mV
$V_{OC(PP)}$	Peak-to-peak common-mode output voltage			50	150	mV
I_{IH}	High-level input current	DE	$V_{IH} = 5 V$	-0.5	-20	μA
		D		2	20	
I_{IL}	Low-level input current	DE	$V_{IL} = 0.8 V$	-0.5	-10	μA
		D		2	10	
I_{OS}	Short-circuit output current	V_{OY} or $V_{OZ} = 0 V$		3	10	mA
		$V_{OD} = 0 V$		3	10	
$I_{O(OFF)}$	Off-state output current	DE = 0 V, $V_{OY} = V_{OZ} = 0 V$	-1		1	μA
		DE = V_{CC} , $V_{OY} = V_{OZ} = 0 V$, $V_{CC} < 1.5 V$				
C_{IN}	Input capacitance			3		pF



SN65LVDS179, SN65LVDS180, SN65LVDS050, SN65LVDS051 HIGH-SPEED DIFFERENTIAL LINE DRIVERS AND RECEIVERS

SLLS301K – APRIL 1998 – REVISED JANUARY 2003

receiver electrical characteristics over recommended operating conditions (unless otherwise noted)

PARAMETER		TEST CONDITIONS	MIN	TYP†	MAX	UNIT
V _{IT+}	Positive-going differential input voltage threshold	See Figure 5 and Table 1			50	mV
V _{IT-}	Negative-going differential input voltage threshold				-50	
V _{OH}	High-level output voltage	I _{OH} = -8 mA		2.4		V
		I _{OH} = -4 mA		2.8		
V _{OL}	Low-level output voltage	I _{OL} = 8 mA			0.4	V
I _I	Input current (A or B inputs)	V _I = 0	-2	-11	-20	μA
		V _I = 2.4 V	-1.2	-3		
I _{I(OFF)}	Power-off input current (A or B inputs)	V _{CC} = 0			±20	μA
I _{IH}	High-level input current (enables)	V _{IH} = 5 V			±10	μA
I _{IL}	Low-level input current (enables)	V _{IL} = 0.8 V			±10	μA
I _{OZ}	High-impedance output current	V _O = 0 or 5 V			±10	μA
C _I	Input capacitance			5		pF

† All typical values are at 25°C and with a 3.3-V supply.

driver switching characteristics over recommended operating conditions (unless otherwise noted)

PARAMETER		TEST CONDITIONS	MIN	TYP†	MAX	UNIT
t _{PLH}	Propagation delay time, low-to-high-level output	R _L = 100 Ω, C _L = 10 pF, See Figure 2		1.7	2.7	ns
t _{PHL}	Propagation delay time, high-to-low-level output			1.7	2.7	ns
t _r	Differential output signal rise time			0.8	1	ns
t _f	Differential output signal fall time			0.8	1	ns
t _{sk(p)}	Pulse skew (t _{pHL} - t _{pLH})‡				300	
t _{sk(o)}	Channel-to-channel output skew§			150		ps
t _{en}	Enable time	See Figure 4		4.3	10	ns
t _{dis}	Disable time			3.1	10	ns

† All typical values are at 25°C and with a 3.3-V.

‡ t_{sk(p)} is the magnitude of the time difference between the high-to-low and low-to-high propagation delay times at an output.

§ t_{sk(o)} is the magnitude of the time difference between the outputs of a single device with all of their inputs connected together.

¶ t_{sk(pp)} is the magnitude of the time difference in propagation delay times between any specified terminals of two devices when both devices operate with the same supply voltages, same temperature, and have identical packages and test circuits.

SN65LVDS179, SN65LVDS180, SN65LVDS050, SN65LVDS051 HIGH-SPEED DIFFERENTIAL LINE DRIVERS AND RECEIVERS

SLLS301K – APRIL 1998 – REVISED JANUARY 2003

receiver switching characteristics over recommended operating conditions (unless otherwise noted)

PARAMETER		TEST CONDITIONS	MIN	TYP†	MAX	UNIT
t _{PLH}	Propagation delay time, low-to-high-level output	C _L = 10 pF, See Figure 6		3.7	4.5	ns
t _{PHL}	Propagation delay time, high-to-low-level output			3.7	4.5	ns
t _{sk(p)}	Pulse skew (t _{pHL} – t _{pLH}) [‡]			0.3		ns
t _r	Output signal rise time			0.7	1.5	ns
t _f	Output signal fall time			0.9	1.5	ns
t _{PZH}	Propagation delay time, high-level-to-high-impedance output	See Figure 7		2.5		ns
t _{PZL}	Propagation delay time, low-level-to-low-impedance output			2.5		ns
t _{PHZ}	Propagation delay time, high-impedance-to-high-level output			7		ns
t _{PLZ}	Propagation delay time, low-impedance-to-high-level output			4		ns

† All typical values are at 25°C and with a 3.3-V.

‡ t_{sk(p)} is the magnitude of the time difference between the high-to-low and low-to-high propagation delay times at an output.

§ t_{sk(o)} is the magnitude of the time difference between the outputs of a single device with all of their inputs connected together.

¶ t_{sk(pp)} is the magnitude of the time difference in propagation delay times between any specified terminals of two devices when both devices operate with the same supply voltages, same temperature, and have identical packages and test circuits.

PARAMETER MEASUREMENT INFORMATION

driver

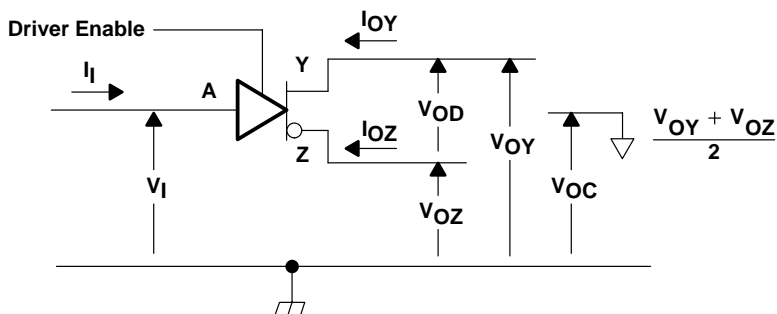
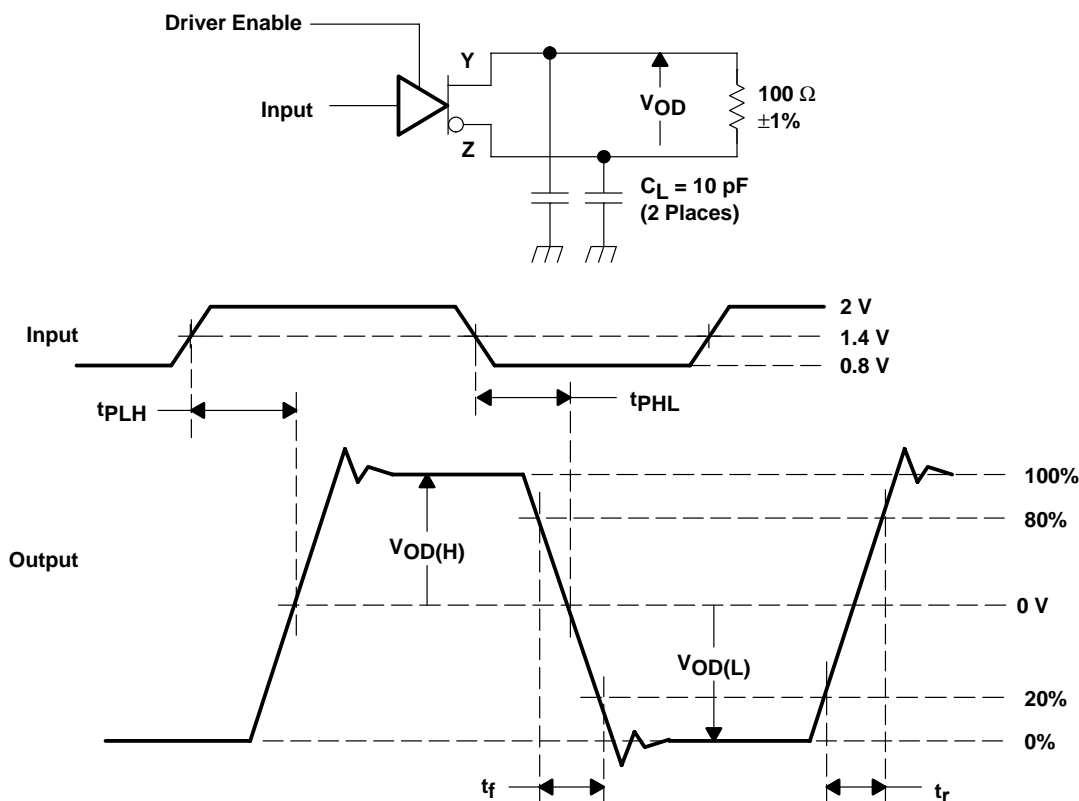

Figure 1. Driver Voltage and Current Definitions



NOTE A: All input pulses are supplied by a generator having the following characteristics: t_r or $t_f \leq 1$ ns, pulse repetition rate (PRR) = 50 Mpps, pulse width = 10 ± 0.2 ns. C_L includes instrumentation and fixture capacitance within 0,06 mm of the D.U.T.

Figure 2. Test Circuit, Timing, and Voltage Definitions for the Differential Output Signal

PARAMETER MEASUREMENT INFORMATION

driver (continued)

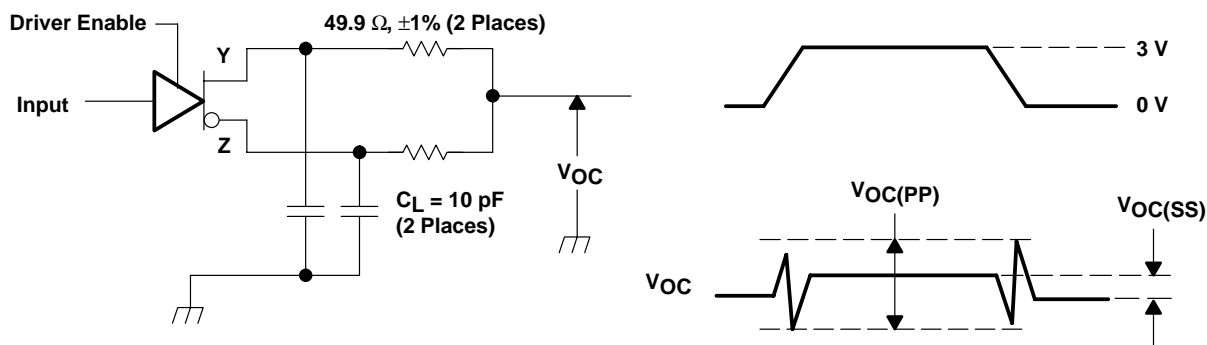

NOTE A: All input pulses are supplied by a generator having the following characteristics: t_r or $t_f \leq 1$ ns, pulse repetition rate (PRR) = 50 Mpps, pulse width = 10 ± 0.2 ns. C_L includes instrumentation and fixture capacitance within 0,06 mm of the D.U.T. The measurement of $V_{OC(PP)}$ is made on test equipment with a -3 dB bandwidth of at least 300 MHz.

Figure 3. Test Circuit and Definitions for the Driver Common-Mode Output Voltage

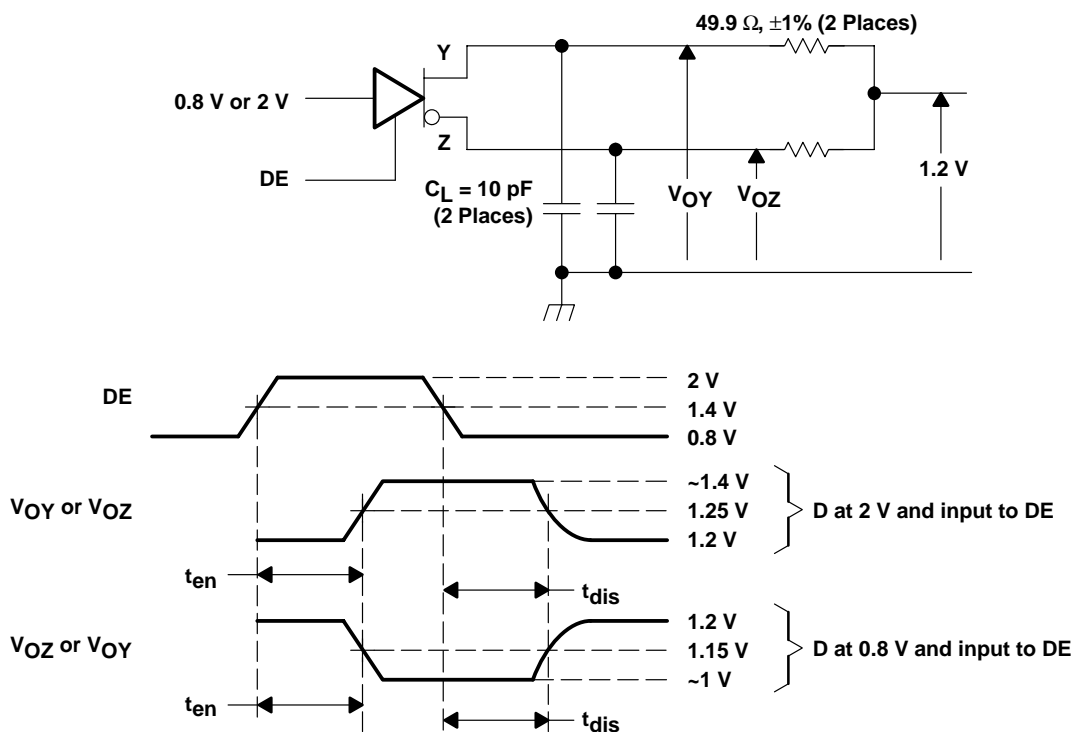

NOTE A: All input pulses are supplied by a generator having the following characteristics: t_r or $t_f \leq 1$ ns, pulse repetition rate (PRR) = 0.5 Mpps, pulse width = 500 ± 10 ns. C_L includes instrumentation and fixture capacitance within 0,06 mm of the D.U.T.

Figure 4. Enable and Disable Time Circuit and Definitions

SN65LVDS179, SN65LVDS180, SN65LVDS050, SN65LVDS051 HIGH-SPEED DIFFERENTIAL LINE DRIVERS AND RECEIVERS

SLLS301K – APRIL 1998 – REVISED JANUARY 2003

PARAMETER MEASUREMENT INFORMATION

receiver

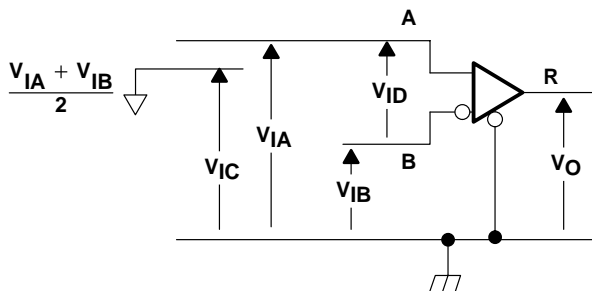

Figure 5. Receiver Voltage Definitions

Table 1. Receiver Minimum and Maximum Input Threshold Test Voltages

APPLIED VOLTAGES (V)		RESULTING DIFFERENTIAL INPUT VOLTAGE (mV)	RESULTING COMMON-MODE INPUT VOLTAGE (V)
V_{IA}	V_{IB}	V_{ID}	V_{IC}
1.25	1.15	100	1.2
1.15	1.25	-100	1.2
2.4	2.3	100	2.35
2.3	2.4	-100	2.35
0.1	0	100	0.05
0	0.1	-100	0.05
1.5	0.9	600	1.2
0.9	1.5	-600	1.2
2.4	1.8	600	2.1
1.8	2.4	-600	2.1
0.6	0	600	0.3
0	0.6	-600	0.3

PARAMETER MEASUREMENT INFORMATION

receiver (continued)

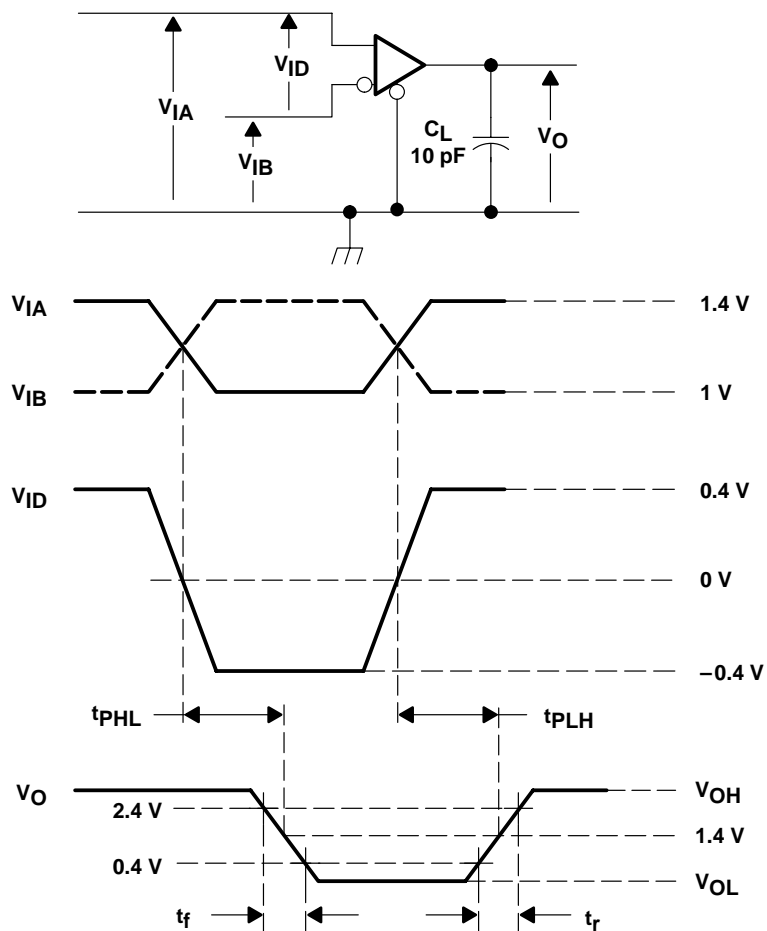

NOTE A: All input pulses are supplied by a generator having the following characteristics: t_r or $t_f \leq 1$ ns, pulse repetition rate (PRR) = 50 Mpps, pulse width = 10 ± 0.2 ns. C_L includes instrumentation and fixture capacitance within 0,06 m of the D.U.T.

Figure 6. Timing Test Circuit and Waveforms

SN65LVDS179, SN65LVDS180, SN65LVDS050, SN65LVDS051 HIGH-SPEED DIFFERENTIAL LINE DRIVERS AND RECEIVERS

SLLS301K – APRIL 1998 – REVISED JANUARY 2003

PARAMETER MEASUREMENT INFORMATION

receiver (continued)

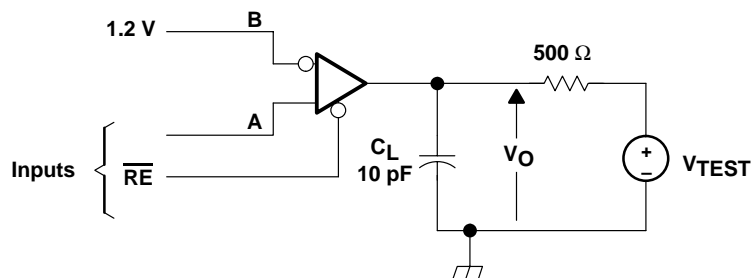

NOTE A: All input pulses are supplied by a generator having the following characteristics: t_r or $t_f \leq 1$ ns, pulse repetition rate (PRR) = 0.5 Mpps, pulse width = 500 ± 10 ns. C_L includes instrumentation and fixture capacitance within 0,06 m of the D.U.T.

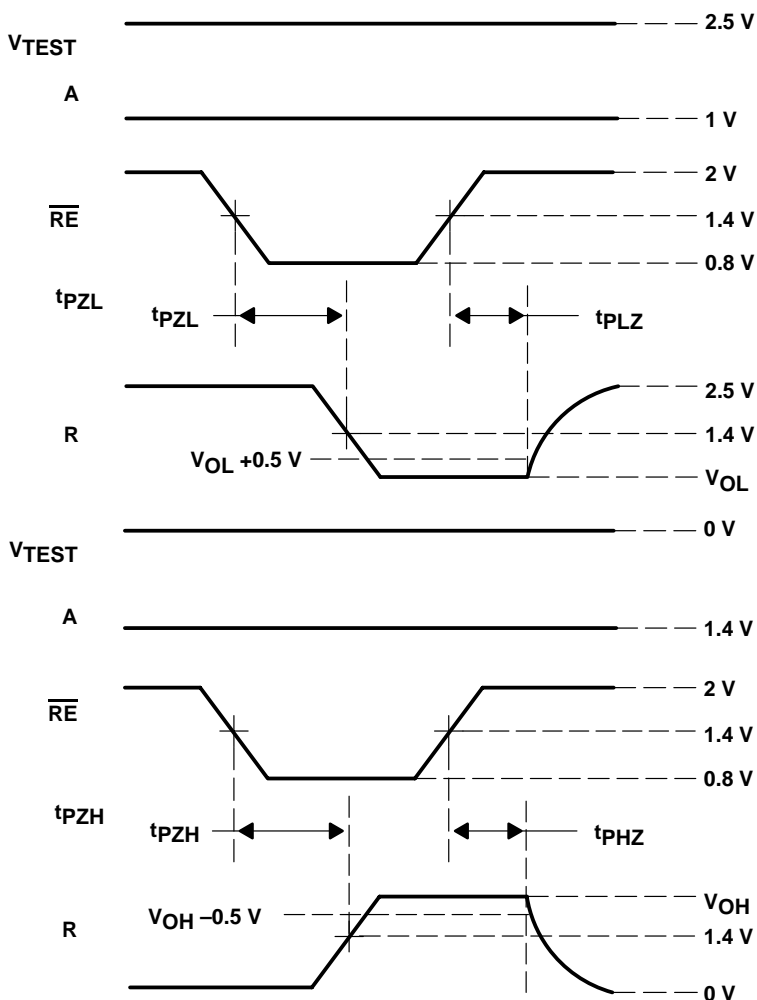

Figure 7. Enable/Disable Time Test Circuit and Waveforms

TYPICAL CHARACTERISTICS

DISABLED DRIVER OUTPUT CURRENT
vs
OUTPUT VOLTAGE

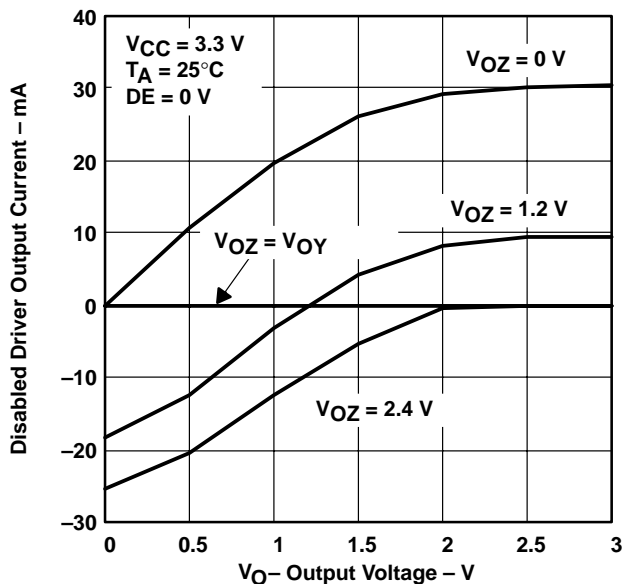

Figure 8

DRIVER
LOW-LEVEL OUTPUT VOLTAGE
vs
LOW-LEVEL OUTPUT CURRENT

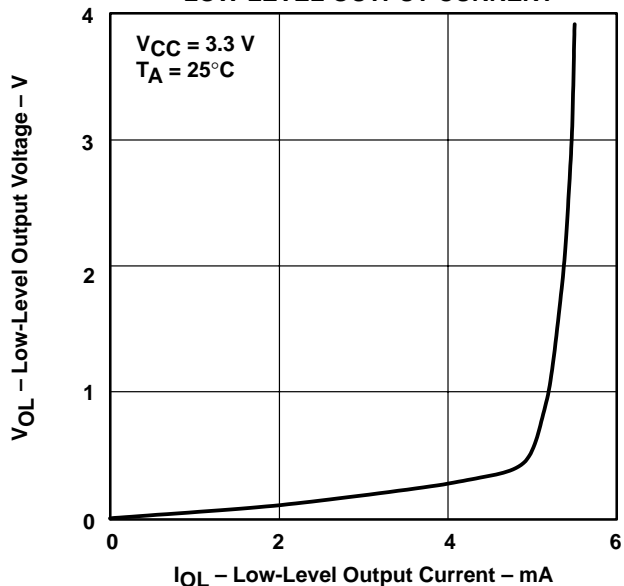

Figure 9

DRIVER
HIGH-LEVEL OUTPUT VOLTAGE
vs
HIGH-LEVEL OUTPUT CURRENT

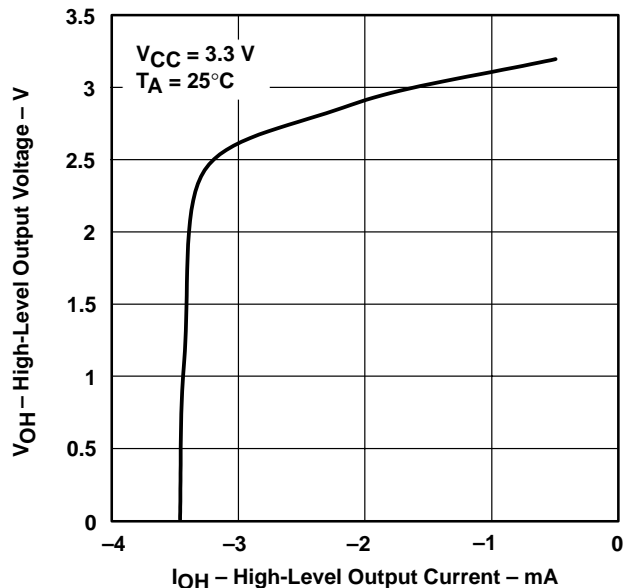

Figure 10

SN65LVDS179, SN65LVDS180, SN65LVDS050, SN65LVDS051 HIGH-SPEED DIFFERENTIAL LINE DRIVERS AND RECEIVERS

SLLS301K – APRIL 1998 – REVISED JANUARY 2003

TYPICAL CHARACTERISTICS

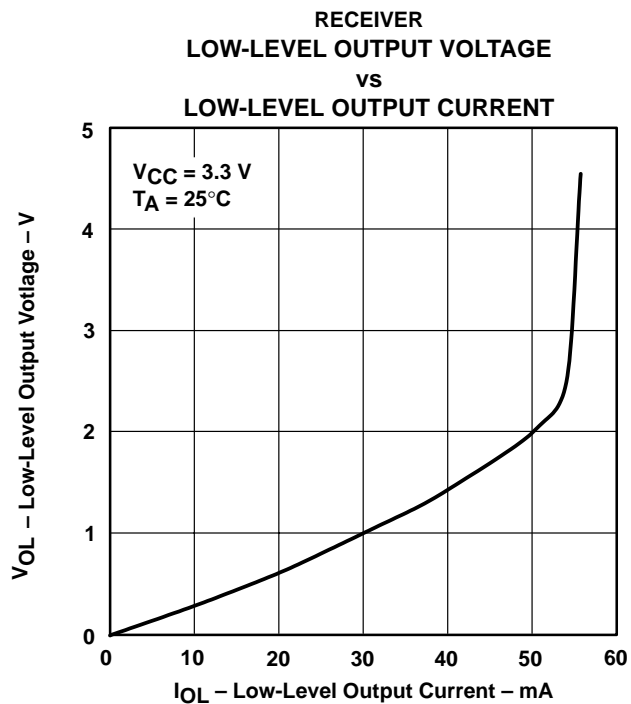

Figure 11

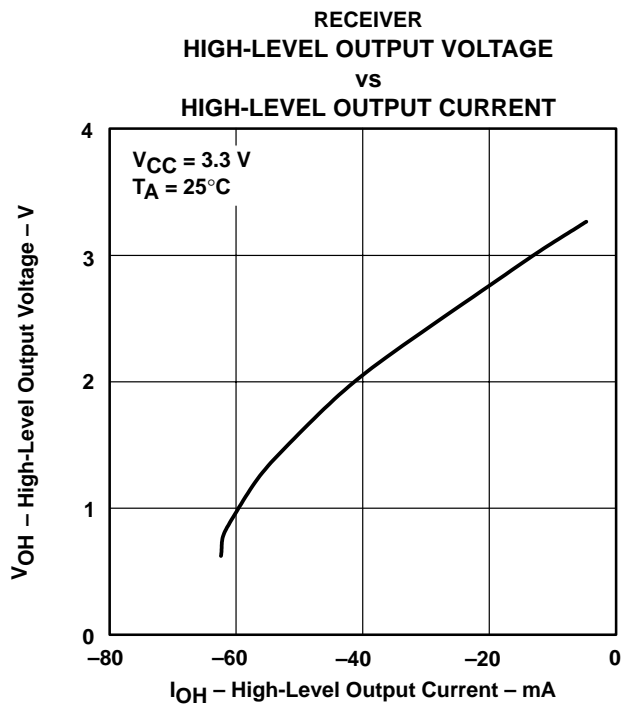

Figure 12

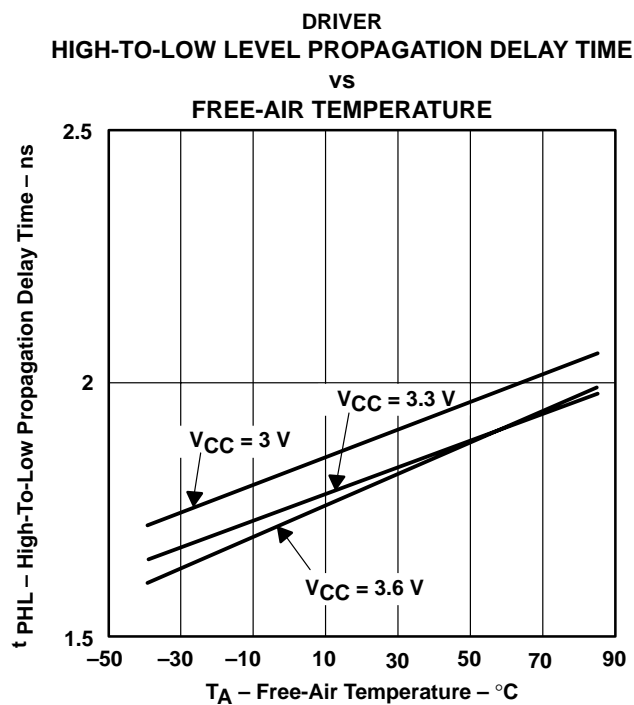

Figure 13

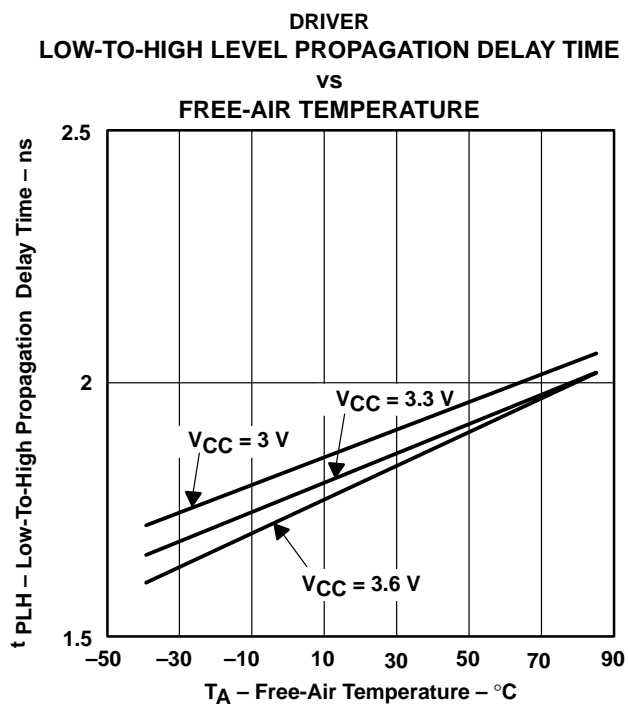

Figure 14



TYPICAL CHARACTERISTICS

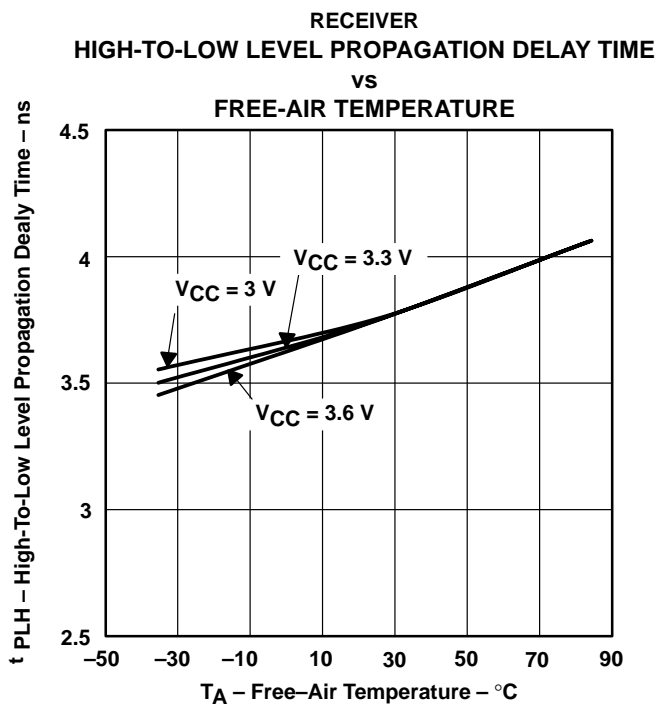

Figure 15

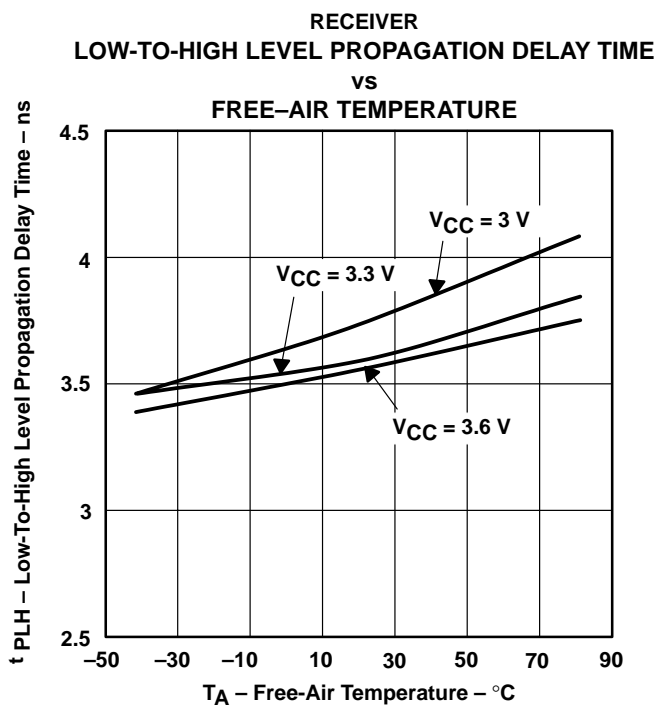

Figure 16

SN65LVDS179, SN65LVDS180, SN65LVDS050, SN65LVDS051 HIGH-SPEED DIFFERENTIAL LINE DRIVERS AND RECEIVERS

SLLS301K – APRIL 1998 – REVISED JANUARY 2003

APPLICATION INFORMATION

The devices are generally used as building blocks for high-speed point-to-point data transmission. Ground differences are less than 1 V with a low common-mode output and balanced interface for very low noise emissions. Devices can interoperate with RS-422, PECL, and IEEE-P1596. Drivers/receivers maintain ECL speeds without the power and dual supply requirements.

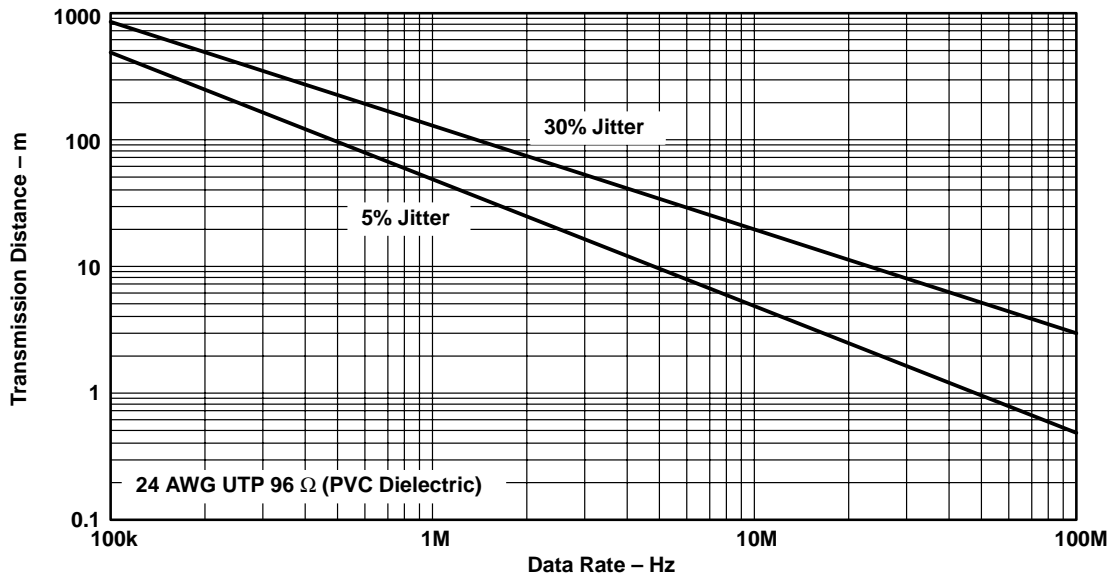

Figure 17. Data Transmission Distance Versus Rate



POST OFFICE BOX 655303 • DALLAS, TEXAS 75265

APPLICATION INFORMATION

fail safe

One of the most common problems with differential signaling applications is how the system responds when no differential voltage is present on the signal pair. The LVDS receiver is like most differential line receivers, in that its output logic state can be indeterminate when the differential input voltage is between -100 mV and 100 mV and within its recommended input common-mode voltage range. TI's LVDS receiver is different in how it handles the open-input circuit situation, however.

Open-circuit means that there is little or no input current to the receiver from the data line itself. This could be when the driver is in a high-impedance state or the cable is disconnected. When this occurs, the LVDS receiver will pull each line of the signal pair to near V_{CC} through $300\text{-k}\Omega$ resistors as shown in Figure 18. The fail-safe feature uses an AND gate with input voltage thresholds at about 2.3 V to detect this condition and force the output to a high-level regardless of the differential input voltage.

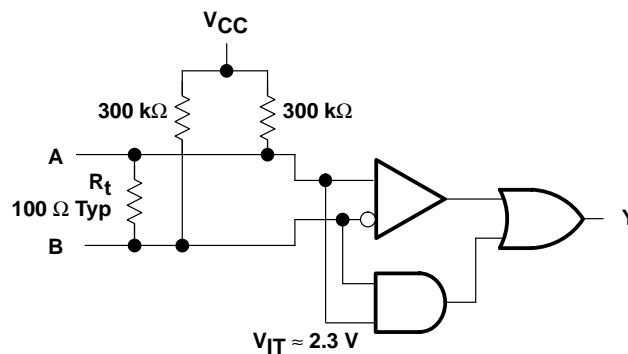

Figure 18. Open-Circuit Fail Safe of the LVDS Receiver

It is only under these conditions that the output of the receiver will be valid with less than a 100-mV differential input voltage magnitude. The presence of the termination resistor, R_t , does not affect the fail-safe function as long as it is connected as shown in the figure. Other termination circuits may allow a dc current to ground that could defeat the pullup currents from the receiver and the fail-safe feature.

SN65LVDS179, SN65LVDS180, SN65LVDS050, SN65LVDS051 HIGH-SPEED DIFFERENTIAL LINE DRIVERS AND RECEIVERS

SLLS301K – APRIL 1998 – REVISED JANUARY 2003

MECHANICAL DATA

D (R-PDSO-G**)

PLASTIC SMALL-OUTLINE PACKAGE

14 PIN SHOWN

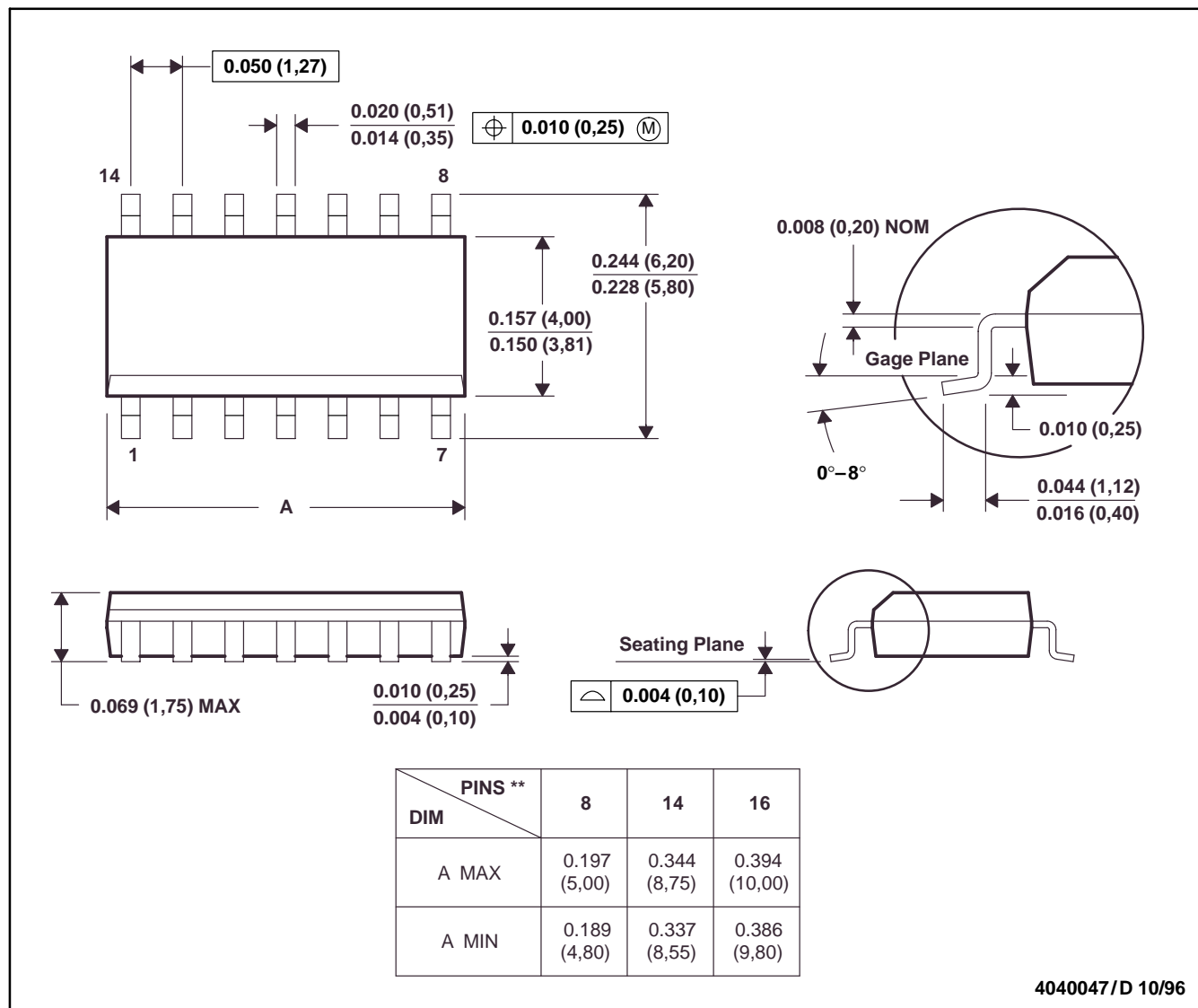

- NOTES: A. All linear dimensions are in inches (millimeters).
 B. This drawing is subject to change without notice.
 C. Body dimensions do not include mold flash or protrusion, not to exceed 0.006 (0,15).
 D. Falls within JEDEC MS-012

SN65LVDS179, SN65LVDS180, SN65LVDS050, SN65LVDS051 HIGH-SPEED DIFFERENTIAL LINE DRIVERS AND RECEIVERS

SLLS301K – APRIL 1998 – REVISED JANUARY 2003

MECHANICAL DATA

DGK (R-PDSO-G8)

PLASTIC SMALL-OUTLINE PACKAGE

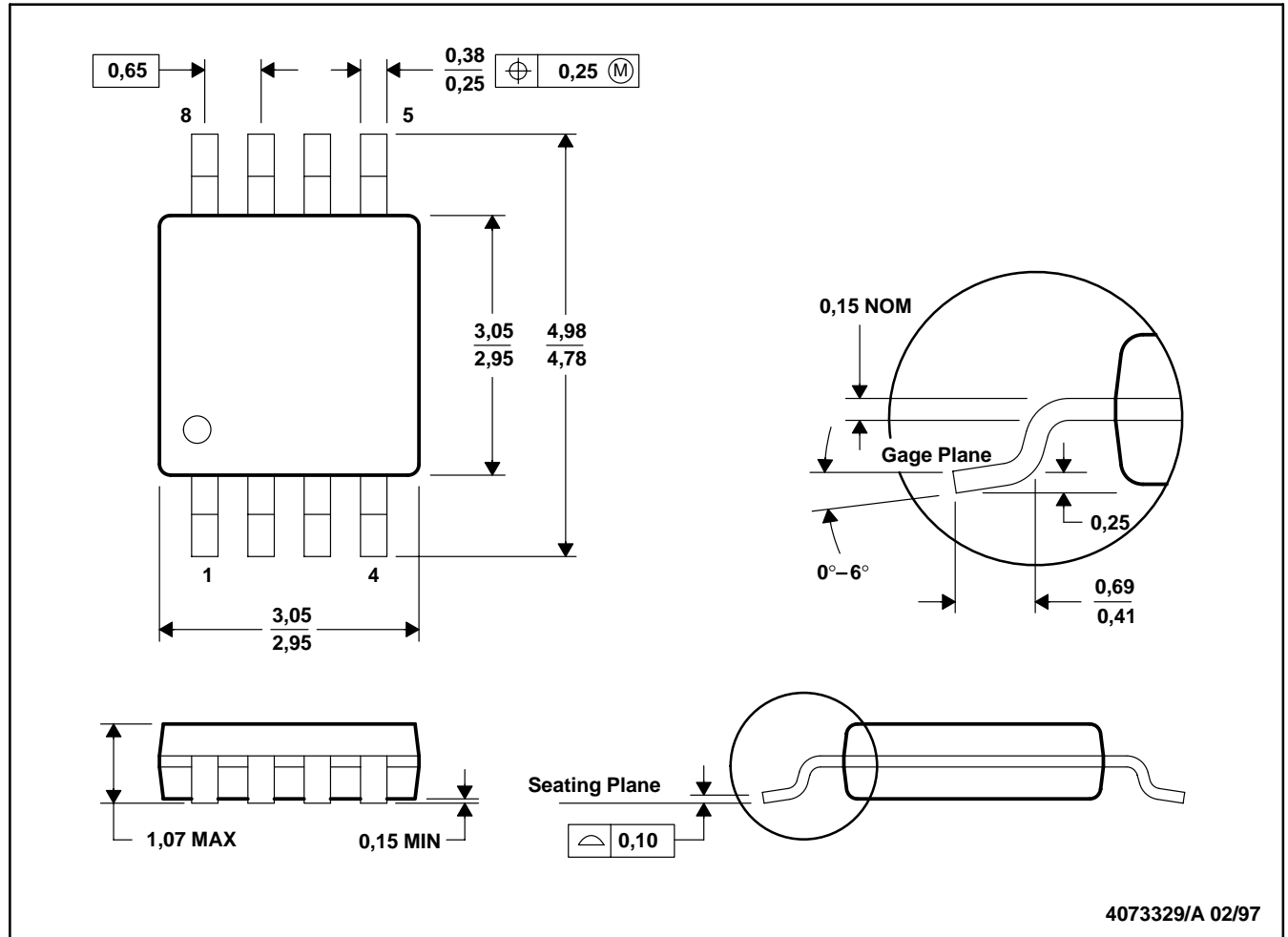

- NOTES:
- All linear dimensions are in millimeters.
 - This drawing is subject to change without notice.
 - Body dimensions do not include mold flash or protrusion.
 - Falls within JEDEC MO-187

SN65LVDS179, SN65LVDS180, SN65LVDS050, SN65LVDS051 HIGH-SPEED DIFFERENTIAL LINE DRIVERS AND RECEIVERS

SLLS301K – APRIL 1998 – REVISED JANUARY 2003

MECHANICAL DATA

PW (R-PDSO-G**)

PLASTIC SMALL-OUTLINE PACKAGE

14 PINS SHOWN

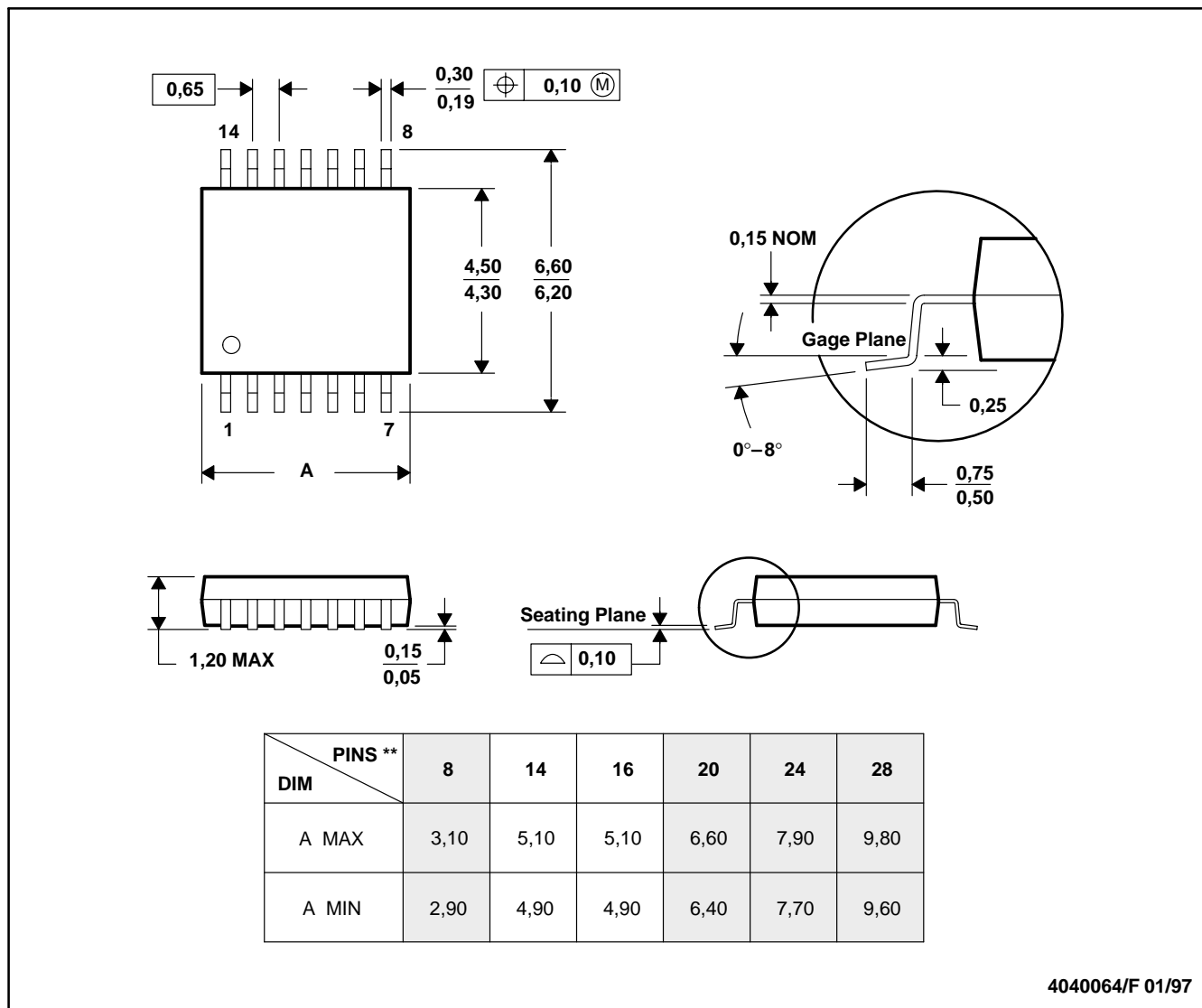

- NOTES: A. All linear dimensions are in millimeters.
 B. This drawing is subject to change without notice.
 C. Body dimensions do not include mold flash or protrusion not to exceed 0,15.
 D. Falls within JEDEC MO-153

IMPORTANT NOTICE

Texas Instruments Incorporated and its subsidiaries (TI) reserve the right to make corrections, modifications, enhancements, improvements, and other changes to its products and services at any time and to discontinue any product or service without notice. Customers should obtain the latest relevant information before placing orders and should verify that such information is current and complete. All products are sold subject to TI's terms and conditions of sale supplied at the time of order acknowledgment.

TI warrants performance of its hardware products to the specifications applicable at the time of sale in accordance with TI's standard warranty. Testing and other quality control techniques are used to the extent TI deems necessary to support this warranty. Except where mandated by government requirements, testing of all parameters of each product is not necessarily performed.

TI assumes no liability for applications assistance or customer product design. Customers are responsible for their products and applications using TI components. To minimize the risks associated with customer products and applications, customers should provide adequate design and operating safeguards.

TI does not warrant or represent that any license, either express or implied, is granted under any TI patent right, copyright, mask work right, or other TI intellectual property right relating to any combination, machine, or process in which TI products or services are used. Information published by TI regarding third-party products or services does not constitute a license from TI to use such products or services or a warranty or endorsement thereof. Use of such information may require a license from a third party under the patents or other intellectual property of the third party, or a license from TI under the patents or other intellectual property of TI.

Reproduction of information in TI data books or data sheets is permissible only if reproduction is without alteration and is accompanied by all associated warranties, conditions, limitations, and notices. Reproduction of this information with alteration is an unfair and deceptive business practice. TI is not responsible or liable for such altered documentation.

Resale of TI products or services with statements different from or beyond the parameters stated by TI for that product or service voids all express and any implied warranties for the associated TI product or service and is an unfair and deceptive business practice. TI is not responsible or liable for any such statements.

Mailing Address:

Texas Instruments
Post Office Box 655303
Dallas, Texas 75265