

SN65LVDS116 16-PORT LVDS REPEATER

SLLS370C – SEPTEMBER 1999 – REVISED DECEMBER 2002

- One Receiver and Sixteen Line Drivers Meet or Exceed the Requirements of ANSI EIA/TIA-644 Standard
- Designed for Signaling Rates Up to 622 Mbps
- Enabling Logic Allows Separate Control of Each Bank of Four Channels or 2-Bit Selection of Any One of the Four Banks
- Low-Voltage Differential Signaling With Typical Output Voltage of 350 mV and a 100-Ω Load
- Electrically Compatible With LVDS, PECL, LVPECL, LVTTTL, LVCMOS, GTL, BTL, CTT, SSTL, or HSTL Outputs With External Termination Networks
- Propagation Delay Times < 4.7 ns
- Output Skew Is < 300 ps and Part-to-Part Skew < 1.5 ns
- Total Power Dissipation Typically 470 mW With All Ports Enabled and at 200 MHz
- Driver Outputs or Receiver Input Is High Impedance When Disabled or With $V_{CC} < 1.5$ V
- Bus-Pin ESD Protection Exceeds 12 kV
- Packaged in Thin Shrink Small-Outline Package With 20 Mil Terminal Pitch

description

The SN65LVDS116 is one differential line receiver connected to sixteen differential line drivers that implement the electrical characteristics of low-voltage differential signaling (LVDS). LVDS, as specified in EIA/TIA-644, is a data signaling technique that offers the low-power, low-noise coupling, and switching speeds to transmit data at speeds up to 622 Mbps and relatively long distances. (Note: The ultimate rate and distance of data transfer is dependent upon the attenuation characteristics of the media, the noise coupling to the environment, and other system characteristics.)

The intended application of this device and signaling technique is for point-to-point or multidrop baseband data transmission over controlled impedance media of approximately 100 Ω. The transmission media may be printed-circuit board traces, backplanes, or cables. The large number of drivers integrated into the same substrate along with the low pulse skew of balanced signaling, allows extremely precise timing alignment of the signals repeated from the input. This is particularly advantageous in system clock distribution.

The SN65LVDS116 is characterised for operation from -40°C to 85°C.

DGG PACKAGE (TOP VIEW)

GND	1	64	A1Y
V _{CC}	2	63	A1Z
V _{CC}	3	62	A2Y
GND	4	61	A2Z
ENA	5	60	A3Y
ENA	6	59	A3Z
NC	7	58	A4Y
NC	8	57	A4Z
NC	9	56	B1Y
ENB	10	55	B1Z
ENB	11	54	B2Y
NC	12	53	B2Z
NC	13	52	B3Y
NC	14	51	B3Z
GND	15	50	B4Y
V _{CC}	16	49	B4Z
V _{CC}	17	48	C1Y
GND	18	47	C1Z
A	19	46	C2Y
B	20	45	C2Z
NC	21	44	C3Y
ENC	22	43	C3Z
ENC	23	42	C4Y
S0	24	41	C4Z
S1	25	40	D1Y
SM	26	39	D1Z
END	27	38	D2Y
END	28	37	D2Z
GND	29	36	D3Y
V _{CC}	30	35	D3Z
V _{CC}	31	34	D4Y
GND	32	33	D4Z



Please be aware that an important notice concerning availability, standard warranty, and use in critical applications of Texas Instruments semiconductor products and disclaimers thereto appears at the end of this data sheet.

PRODUCTION DATA information is current as of publication date. Products conform to specifications per the terms of Texas Instruments standard warranty. Production processing does not necessarily include testing of all parameters.

 **TEXAS
INSTRUMENTS**

POST OFFICE BOX 655303 • DALLAS, TEXAS 75265

Copyright © 2002, Texas Instruments Incorporated

SN65LVDS116 16-PORT LVDS REPEATER

SLLS370C – SEPTEMBER 1999 – REVISED DECEMBER 2002

logic diagram (positive logic)

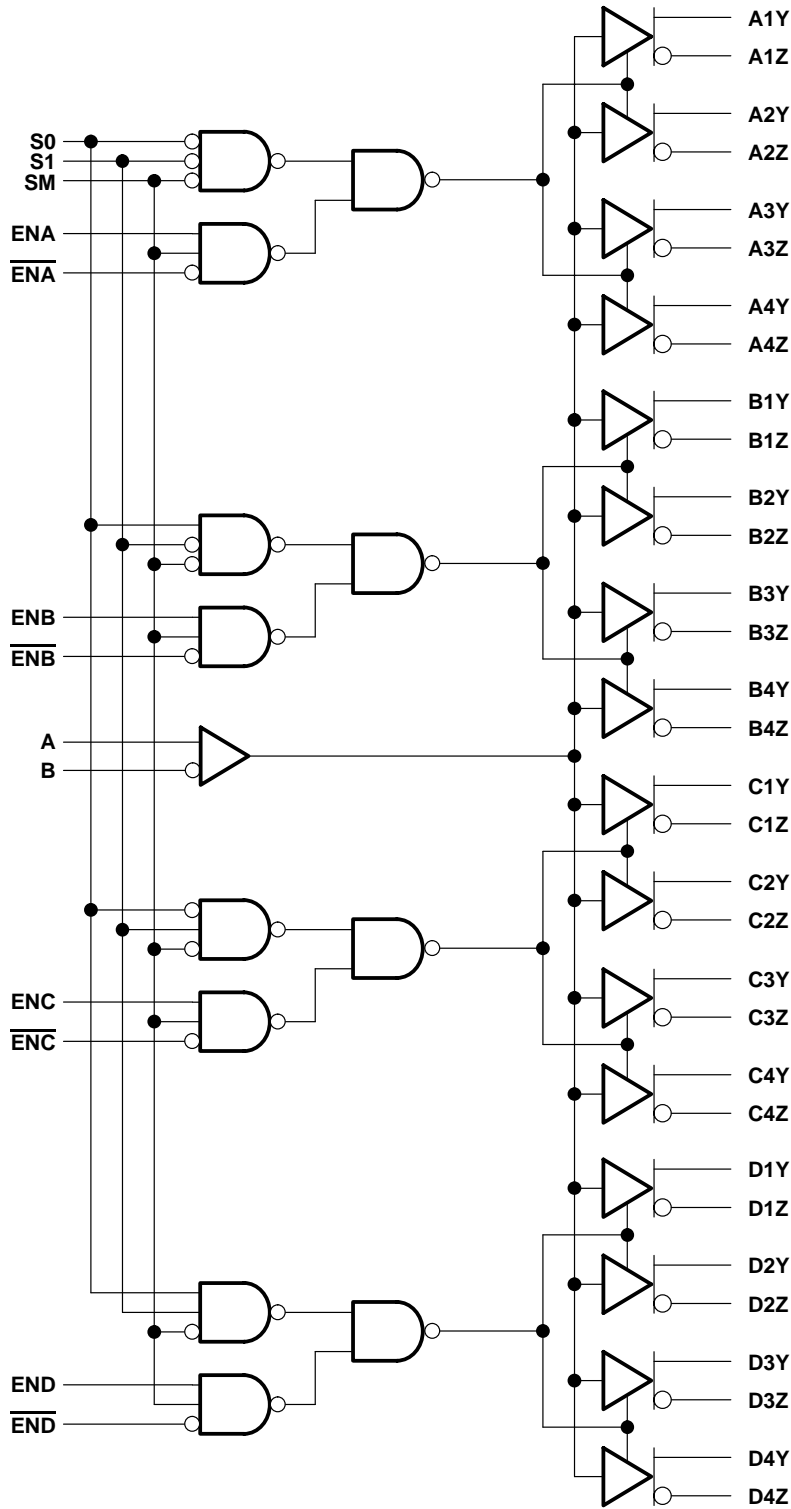

FUNCTION TABLE

INPUT						OUTPUT							
$V_{ID} = V_A - V_B$	SM	EN	\overline{EN}	S1	S0	AY	AZ	BY	BZ	CY	CZ	DY	DZ
X	H	L	X	X	X	Z	Z	Z	Z	Z	Z	Z	Z
$V_{ID} \geq 100$ mV	H	H	L	X	X	H	L	H	L	H	L	H	L
-100 mV < V_{ID} < 100 mV	H	H	L	X	X	?	?	?	?	?	?	?	?
$V_{ID} \leq -100$ mV	H	H	L	X	X	L	H	L	H	L	H	L	H
X	H	X	H	X	X	Z	Z	Z	Z	Z	Z	Z	Z
$V_{ID} \geq 100$ mV	L	X	X	L	L	H	L	Z	Z	Z	Z	Z	Z
-100 mV < V_{ID} < 100 mV	L	X	X	L	L	?	?	Z	Z	Z	Z	Z	Z
$V_{ID} \leq -100$ mV	L	X	X	L	L	L	H	Z	Z	Z	Z	Z	Z
$V_{ID} \geq 100$ mV	L	X	X	L	H	Z	Z	H	L	Z	Z	Z	Z
-100 mV < V_{ID} < 100 mV	L	X	X	L	H	Z	Z	?	?	Z	Z	Z	Z
$V_{ID} \leq -100$ mV	L	X	X	L	H	Z	Z	L	H	Z	Z	Z	Z
$V_{ID} \geq 100$ mV	L	X	X	H	L	Z	Z	Z	Z	H	L	Z	Z
-100 mV < V_{ID} < 100 mV	L	X	X	H	L	Z	Z	Z	Z	?	?	Z	Z
$V_{ID} \leq -100$ mV	L	X	X	H	L	Z	Z	Z	Z	L	H	Z	Z
$V_{ID} \geq 100$ mV	L	X	X	H	H	Z	Z	Z	Z	Z	Z	H	L
-100 mV < V_{ID} < 100 mV	L	X	X	H	H	Z	Z	Z	Z	Z	Z	?	?
$V_{ID} \leq -100$ mV	L	X	X	H	H	Z	Z	Z	Z	Z	Z	L	H

H = high level, L = low level, Z = high impedance, ? = indeterminate

equivalent input and output schematic diagrams

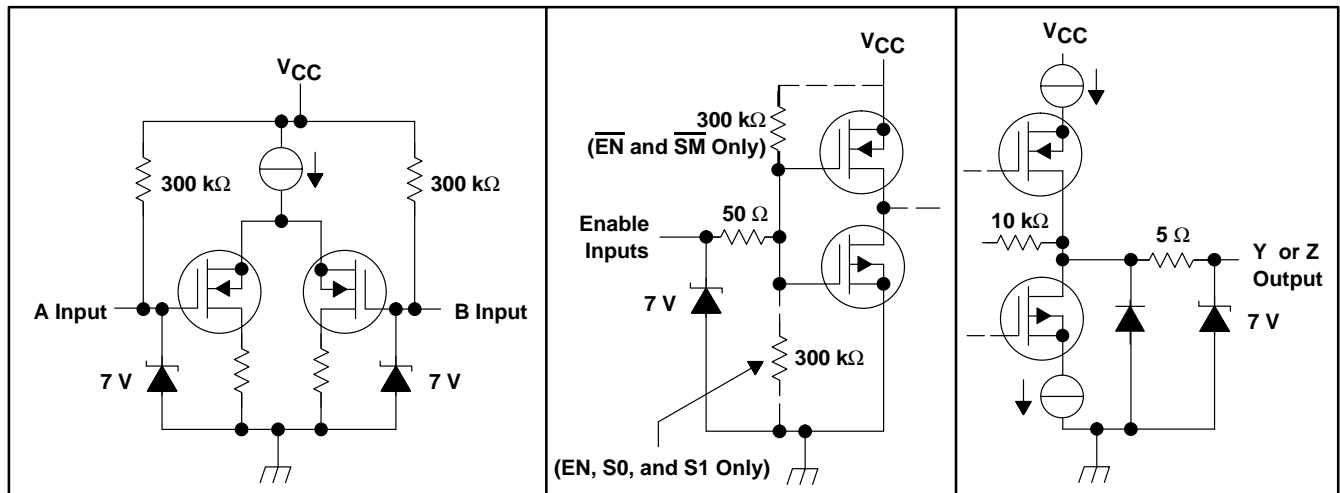

SN65LVDS116

16-PORT LVDS REPEATER

SLLS370C – SEPTEMBER 1999 – REVISED DECEMBER 2002

absolute maximum ratings over operating free-air temperature (unless otherwise noted)†

Supply voltage range, V_{CC} (see Note 1)	–0.5 V to 4 V
Input voltage range, Enable inputs	–0.5 V to 6 V
A, B, Y, or Z	–0.5 V to 4 V
Electrostatic discharge, A, B, Y, Z, and GND (see Note 2)	Class 3, A:12 kV, B: 500 V
Continuous power dissipation	See Dissipation Rating Table
Storage temperature range	–65°C to 150°C
Lead temperature 1,6 mm (1/16 inch) from case for 10 seconds	260°C

† Stresses beyond those listed under “absolute maximum ratings” may cause permanent damage to the device. These are stress ratings only, and functional operation of the device at these or any other conditions beyond those indicated under “recommended operating conditions” is not implied. Exposure to absolute-maximum-rated conditions for extended periods may affect device reliability.

- NOTES: 1. All voltage values, except differential I/O bus voltages, are with respect to network ground terminal.
 2. Tested in accordance with MIL-STD-883C Method 3015.7.

DISSIPATION RATING TABLE

PACKAGE	$T_A \leq 25^\circ\text{C}$ POWER RATING	DERATING FACTOR‡ ABOVE $T_A = 25^\circ\text{C}$	$T_A = 85^\circ\text{C}$ POWER RATING
DGG	2094 mW	16.7 mW/°C	1089 mW

‡ This is the inverse of the junction-to-ambient thermal resistance when board-mounted (low-k) with no air flow.

recommended operating conditions

	MIN	NOM	MAX	UNIT
Supply voltage, V_{CC}	3	3.3	3.6	V
High-level input voltage, V_{IH}	2			V
Low-level input voltage, V_{IL}			0.8	V
Voltage at any bus terminal (separately or common-mode), V_I or V_{IC}	0		$V_{CC}-0.8$	V
Operating free-air temperature, T_A	–40		85	°C



electrical characteristics over recommended operating conditions (unless otherwise noted)

PARAMETER		TEST CONDITIONS	MIN	TYP†	MAX	UNIT
V _{ITH+}	Positive-going differential input voltage threshold	See Figure 1 and Table 1			100	mV
V _{ITH-}	Negative-going differential input voltage threshold				-100	
V _{OD}	Differential output voltage magnitude	R _L = 100 Ω, V _{ID} = ±100 mV, See Figure 1 and Figure 2	247	340	454	mV
Δ V _{OD}	Change in differential output voltage magnitude between logic states				50	
V _{OC(SS)}	Steady-state common-mode output voltage	See Figure 3	1.125		1.375	V
ΔV _{OC(SS)}	Change in steady-state common-mode output voltage between logic states				50	mV
V _{OC(PP)}	Peak-to-peak common-mode output voltage			50	150	
I _{CC}	Supply current	Enabled, R _L = 100 Ω		84	115	mA
		Disabled, EN _x = V _{CC} or EN _x = 0 V		3.2	6	
I _I	Input current (A or B inputs)‡	V _I = 0 V		-2	-20	μA
		V _I = 2.4 V		-1.2		
I _{I(OFF)}	Power-off input current (A or B inputs)	V _{CC} = 1.5 V, V _I = 2.4 V			20	μA
I _{IH}	High-level input current	EN _x , S0, S1	V _{IH} = 2 V		20	μA
		EN _x , SM			-20	
I _{IL}	Low-level input current	EN _x , S0, S1	V _{IL} = 0.8 V		10	μA
		EN _x , SM			-10	
I _{OS}	Short-circuit output current	V _{OY} or V _{OZ} = 0 V			±24	mA
		V _{OD} = 0 V			±12	
I _{OZ}	High-impedance output current	V _O = 0 V or V _{CC}			±1	μA
I _{O(OFF)}	Power-off output current	V _{CC} = 1.5 V, V _O = 3.6 V			±1	μA
C _{IN}	Input capacitance (A or B inputs)	V _I = 0.4 sin(4E6πt) + 0.5 V		5		pF
C _O	Output capacitance (Y or Z outputs)	V _I = 0.4 sin(4E6πt) + 0.5 V		9.4		

† All typical values are at 25°C and with a 3.3-V supply.

‡ The non-algebraic convention, where the more positive (least negative) limit is designated minimum, is used in this data sheet for the input current (I_I) only.

switching characteristics over recommended operating conditions (unless otherwise noted)

PARAMETER		TEST CONDITIONS	MIN	TYP†	MAX	UNIT
t _{PLH}	Propagation delay time, low-to-high-level output	R _L = 100 Ω, C _L = 10 pF, See Figure 4	2.2	3.1	4.7	ns
t _{PHL}	Propagation delay time, high-to-low-level output		2.2	3.1	4.7	
t _r	Differential output signal rise time		0.3	0.8	1.2	ns
t _f	Differential output signal fall time		0.3	0.8	1.2	
t _{sk(p)}	Pulse skew (t _{PHL} - t _{PLH})‡			140	500	ps
t _{sk(o)}	Output skew, channel-to-channel§			100	300	
t _{sk(pp)}	Part-to-part skew¶				1.5	ns
t _{PZH}	Propagation delay time, high-impedance-to-high-level output	See Figure 5		5.7	15	ns
t _{PZL}	Propagation delay time, high-impedance-to-low-level output			7.7	15	
t _{PHZ}	Propagation delay time, high-level-to-high-impedance output			3.2	15	
t _{PLZ}	Propagation delay time, low-level-to-high-impedance output			3.2	15	ns

† All typical values are at 25°C and with a 3.3-V supply.

‡ t_{sk(p)} is the magnitude of the time difference between the t_{PLH} and t_{PHL} of any output of a single device.

§ t_{sk(o)} is the magnitude of the time difference between the t_{PLH} or t_{PHL} measured at any two outputs.

¶ t_{sk(pp)} is the magnitude of the time difference in propagation delay times between any specified terminals of two devices when both devices operate with the same supply voltages, at the same temperature, and have identical packages and test circuits.

SN65LVDS116 16-PORT LVDS REPEATER

SLLS370C – SEPTEMBER 1999 – REVISED DECEMBER 2002

PARAMETER MEASUREMENT INFORMATION

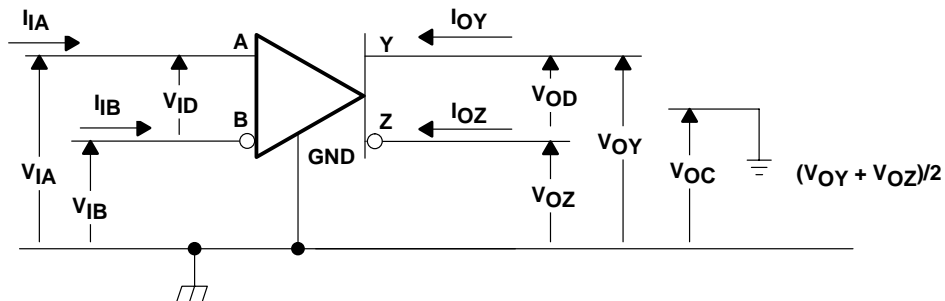

Figure 1. Voltage and Current Definitions

Table 1. Receiver Minimum and Maximum Input Threshold Test Voltages

APPLIED VOLTAGES		RESULTING DIFFERENTIAL INPUT VOLTAGE	RESULTING COMMON-MODE INPUT VOLTAGE
V _{IA}	V _{IB}	V _{ID}	V _{IC}
1.25 V	1.15 V	100 mV	1.2 V
1.15 V	1.25 V	-100 mV	1.2 V
2.4 V	2.3 V	100 mV	2.35 V
2.3 V	2.4 V	-100 mV	2.35 V
0.1 V	0 V	100 mV	0.05 V
0 V	0.1 V	-100 mV	0.05 V
1.5 V	0.9 V	600 mV	1.2 V
0.9 V	1.5 V	-600 mV	1.2 V
2.4 V	1.8 V	600 mV	2.1 V
1.8 V	2.4 V	-600 mV	2.1 V
0.6 V	0 V	600 mV	0.3 V
0 V	0.6 V	-600 mV	0.3 V

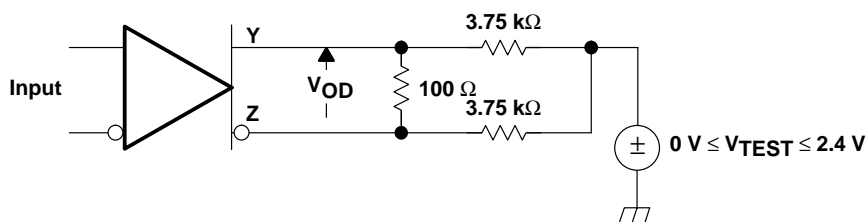
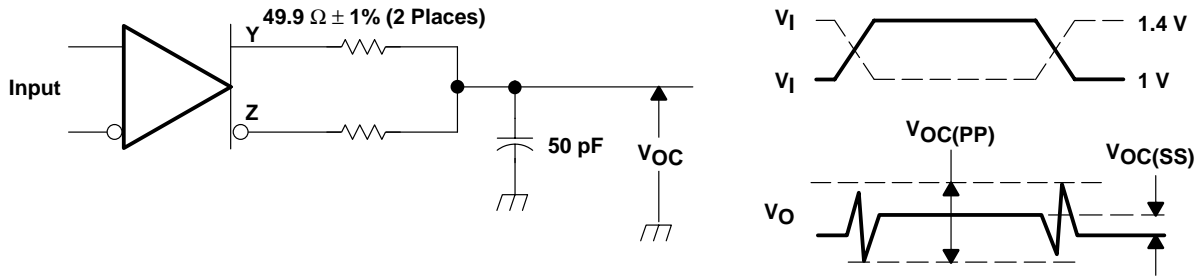

Figure 2. VOD Test Circuit

PARAMETER MEASUREMENT INFORMATION



NOTE A: All input pulses are supplied by a generator having the following characteristics: t_r or $t_f \leq 1$ ns, pulse repetition rate (PRR) = 0.5 Mpps, pulse width = 500 ± 10 ns. C_L includes instrumentation and fixture capacitance within 0,06 mm of the D.U.T. The measurement of $V_{OC}(PP)$ is made on test equipment with a -3 dB bandwidth of at least 300 MHz.

Figure 3. Test Circuit and Definitions for the Driver Common-Mode Output Voltage

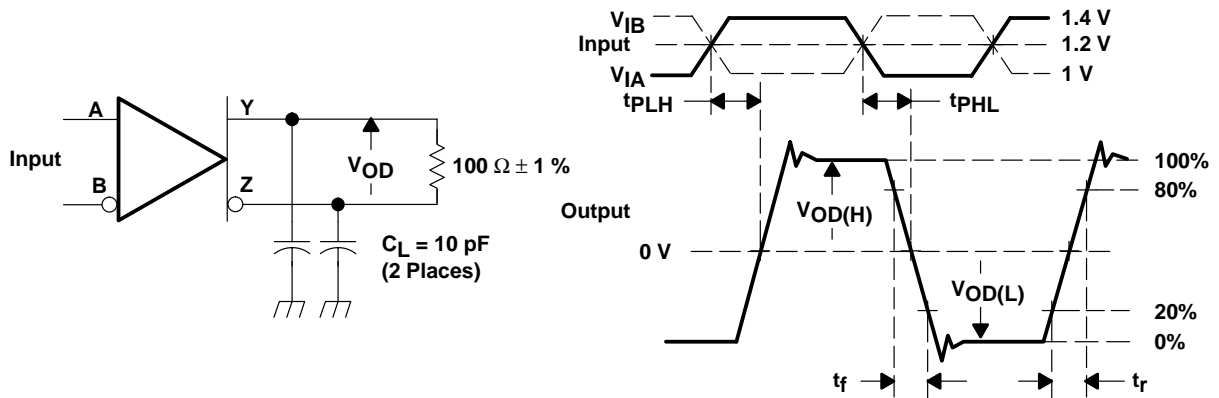

NOTE A: All input pulses are supplied by a generator having the following characteristics: t_r or $t_f \leq 1$ ns, pulse repetition rate (PRR) = 50 Mpps, pulse width = 10 ± 0.2 ns. C_L includes instrumentation and fixture capacitance within 0,06 mm of the D.U.T.

Figure 4. Test Circuit, Timing, and Voltage Definitions for the Differential Output Signal

SN65LVDS116 16-PORT LVDS REPEATER

SLLS370C – SEPTEMBER 1999 – REVISED DECEMBER 2002

PARAMETER MEASUREMENT INFORMATION

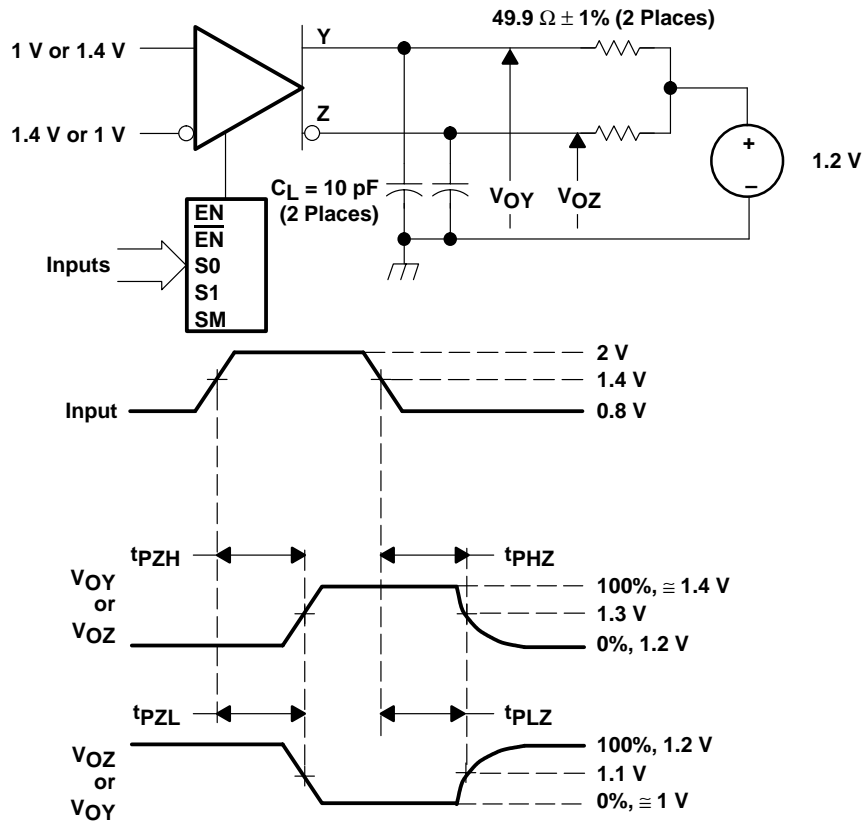

NOTE A: All input pulses are supplied by a generator having the following characteristics: t_r or $t_f \leq 1$ ns, pulse repetition rate (PRR) = 0.5 Mpps, pulse width = 500 ± 10 ns. C_L includes instrumentation and fixture capacitance within 0,06 mm of the D.U.T.

Figure 5. Enable and Disable Time Circuit and Definitions

TYPICAL CHARACTERISTICS

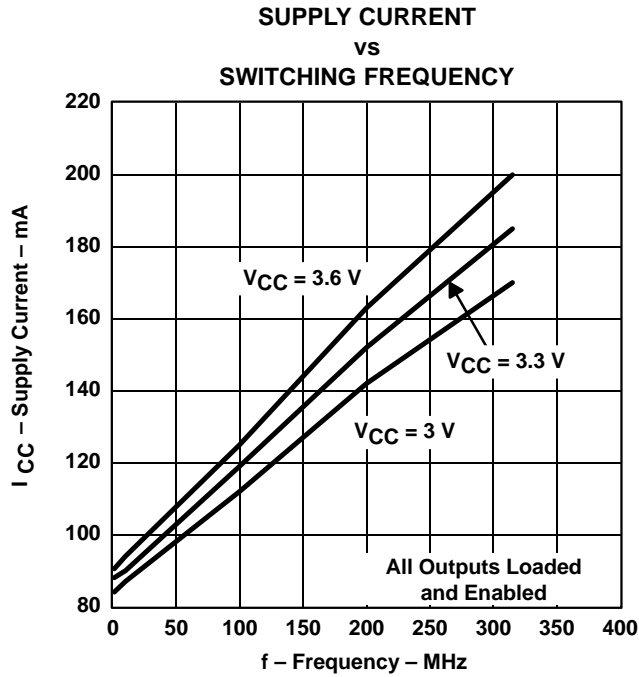

Figure 6

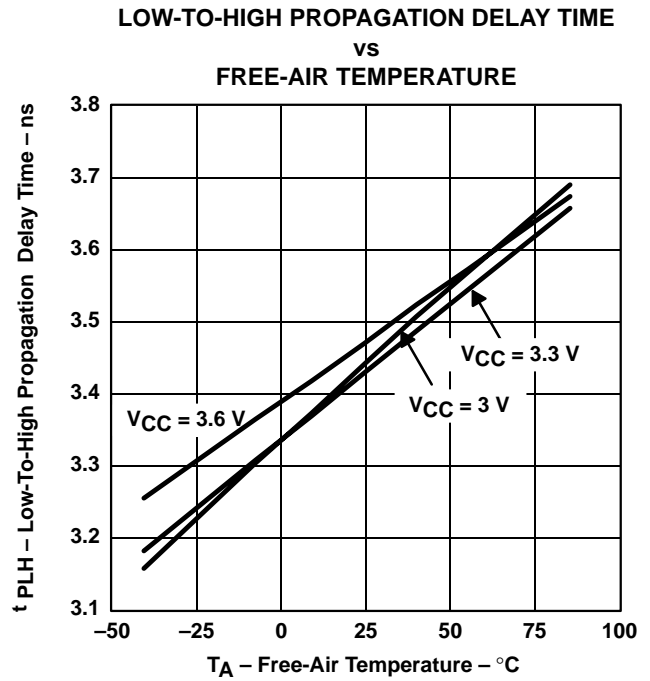

Figure 7

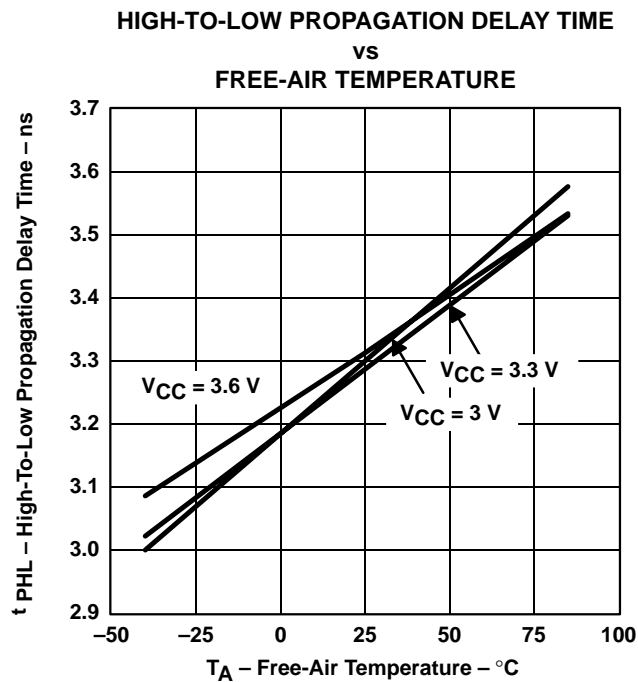

Figure 8

TYPICAL CHARACTERISTICS

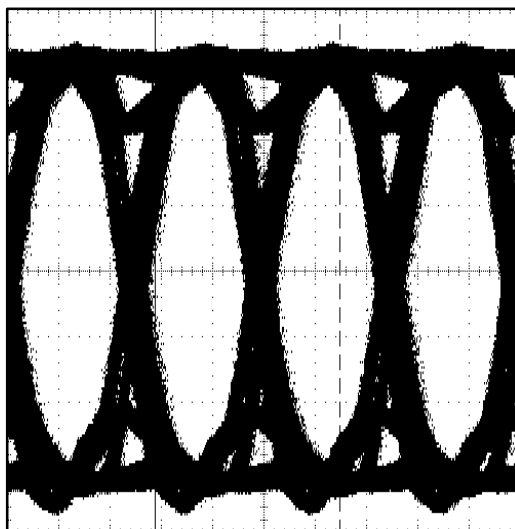

Figure 9. Typical Differential Eye Pattern at 400 Mbps

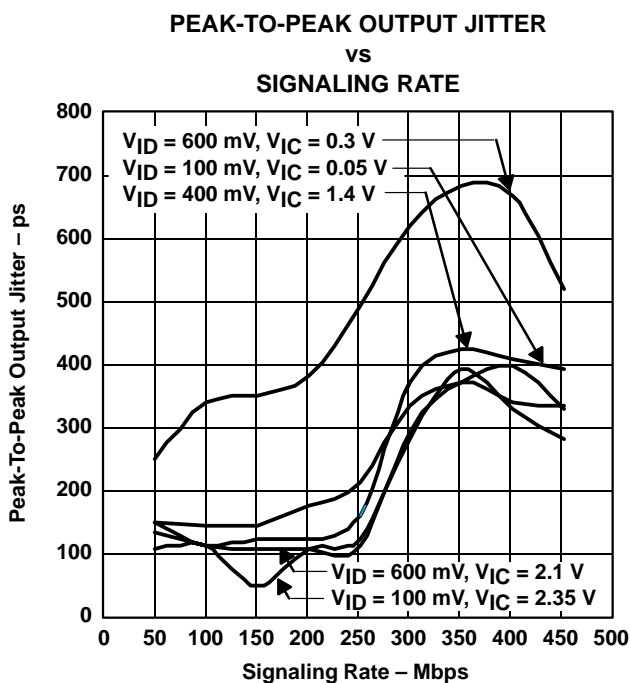

Figure 10. Typical Peak-To-Peak Output Jitter vs V_{ID} and V_{IC}

APPLICATION INFORMATION

An LVDS receiver can be used to receive various other types of logic signals. Figure 11 through Figure 19 show the termination circuits for SSTL, HSTL, GTL, BTL, LVPECL, PECL, CMOS, and TTL.

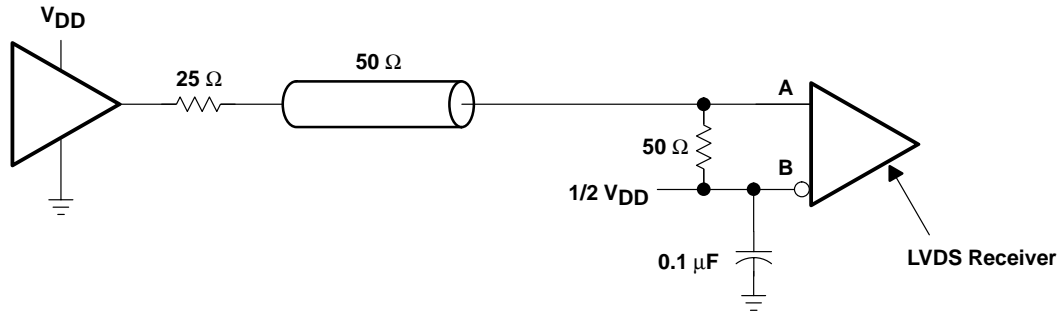

Figure 11. Stub-Series Terminated (SSTL) or High-Speed Transceiver Logic (HSTL)

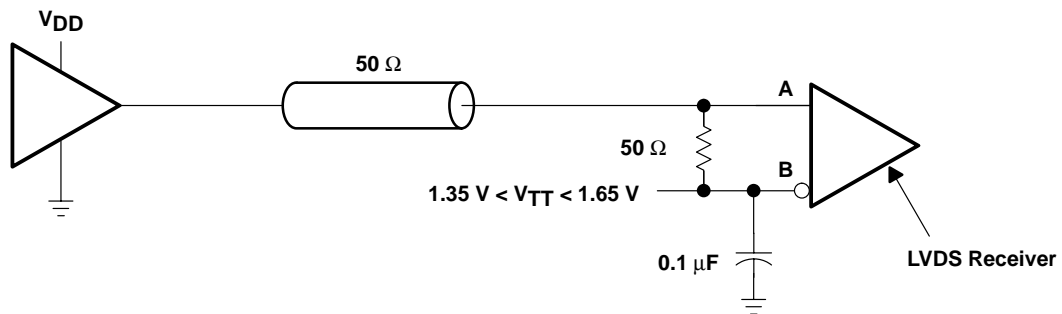

Figure 12. Center-Tap Termination (CTT)

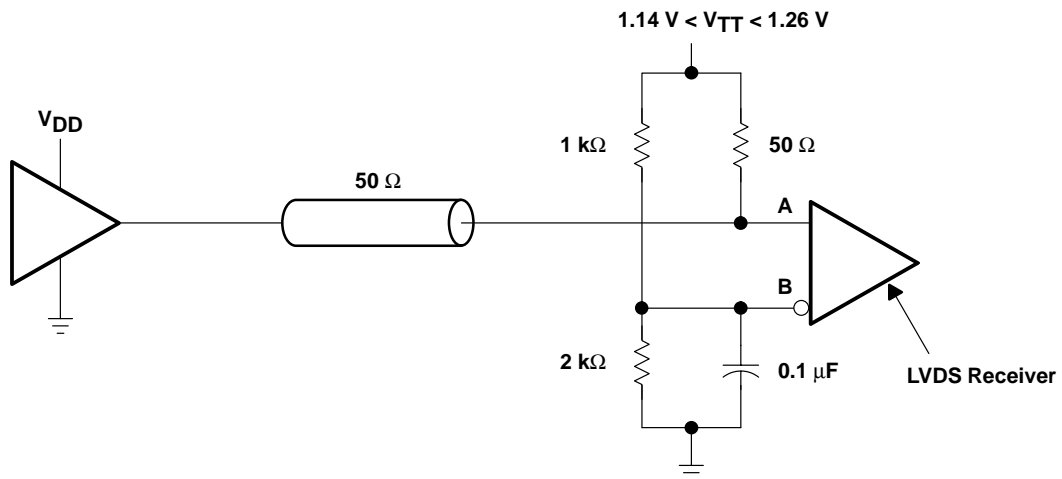

Figure 13. Gunning Transceiver Logic (GTL)

SN65LVDS116 16-PORT LVDS REPEATER

SLLS370C – SEPTEMBER 1999 – REVISED DECEMBER 2002

APPLICATION INFORMATION

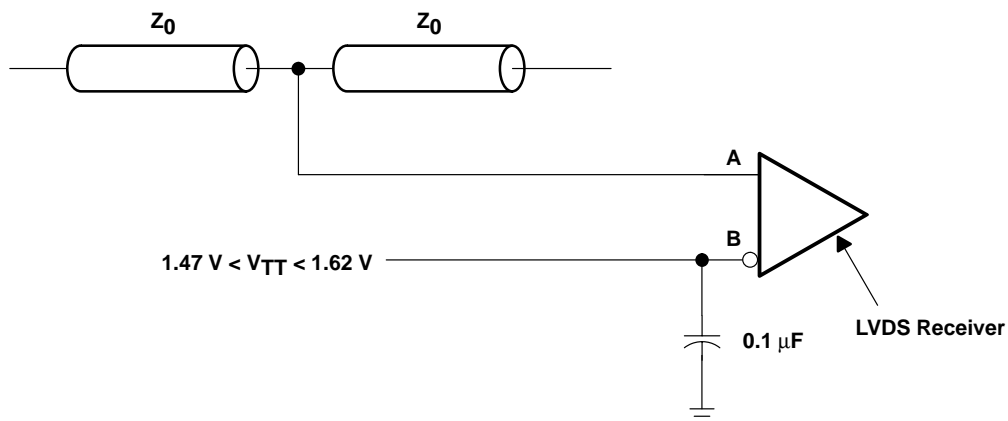

Figure 14. Backplane Transceiver Logic (BTL)

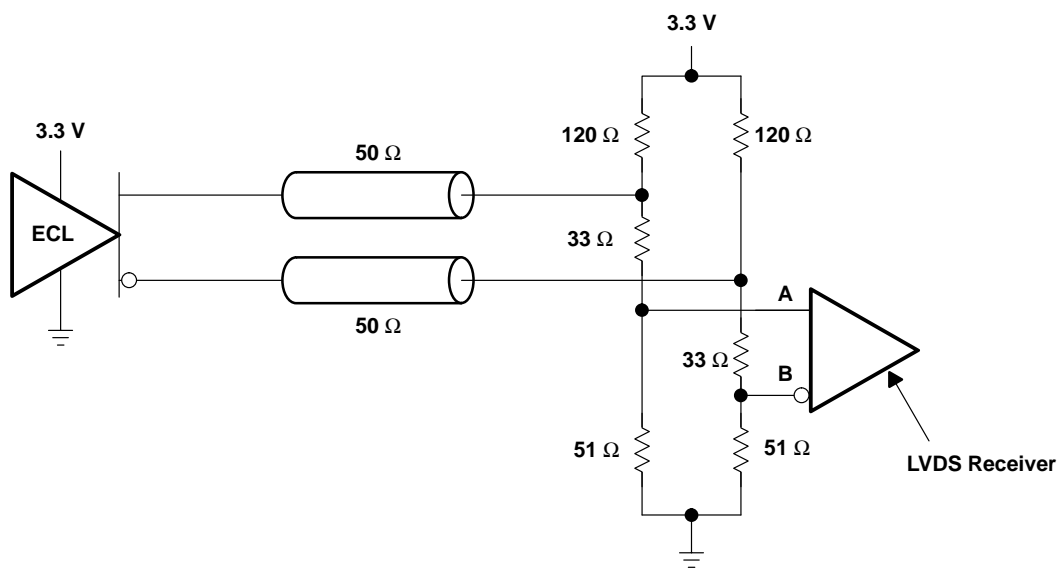

Figure 15. Low-Voltage Positive Emitter-Coupled Logic (LVPECL)

APPLICATION INFORMATION

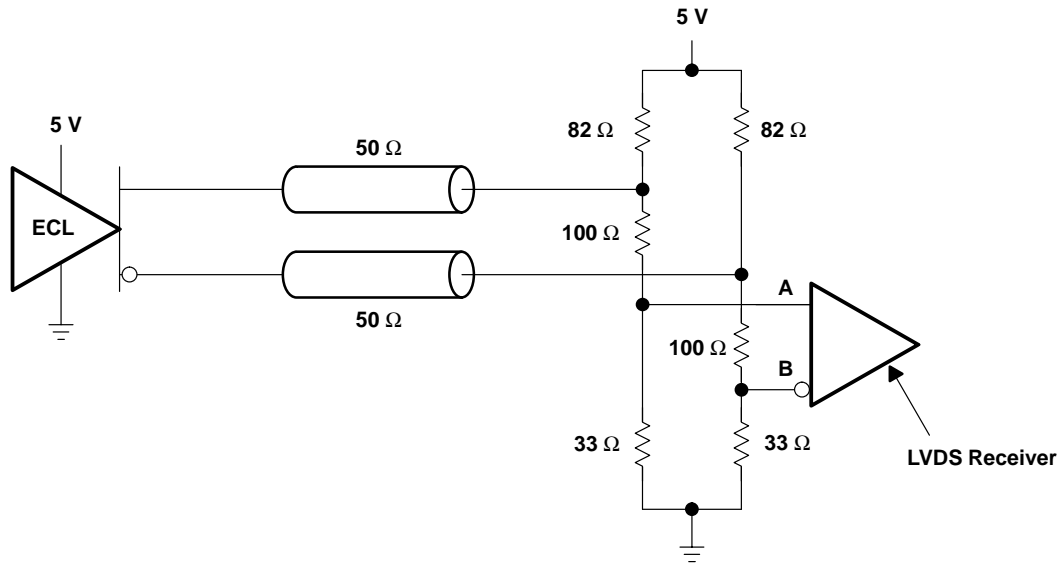

Figure 16. Positive Emitter-Coupled Logic (PECL)

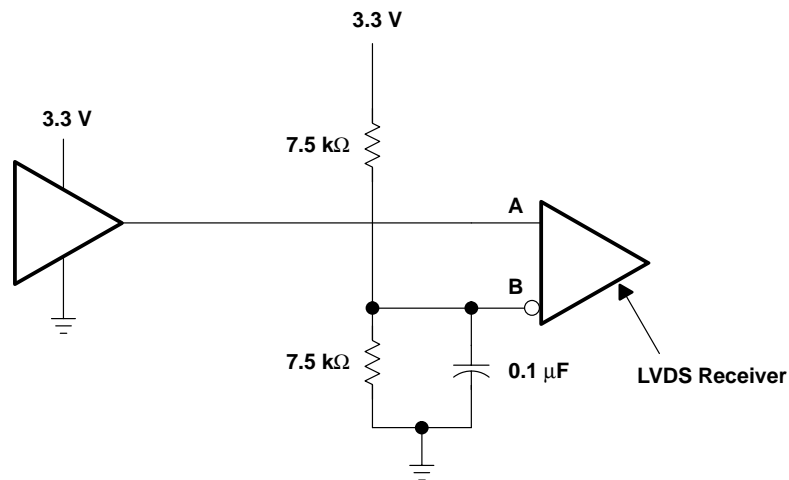

Figure 17. 3.3-V CMOS

SN65LVDS116 16-PORT LVDS REPEATER

SLLS370C – SEPTEMBER 1999 – REVISED DECEMBER 2002

APPLICATION INFORMATION

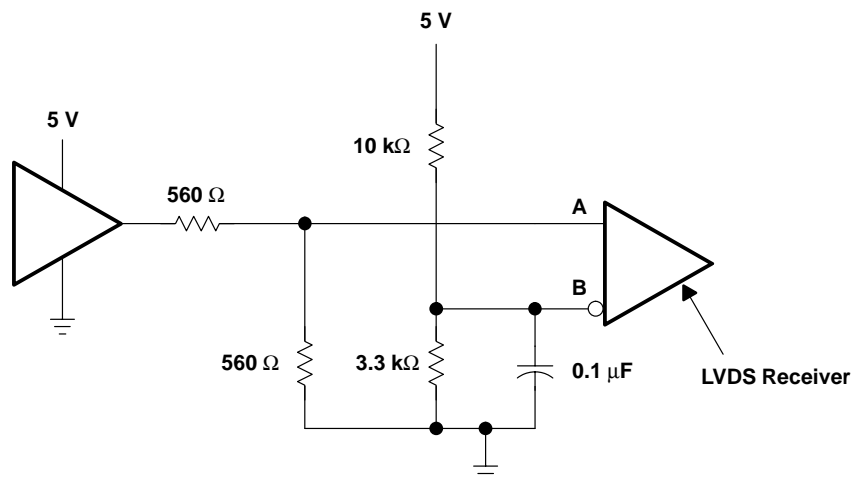

Figure 18. 5-V CMOS

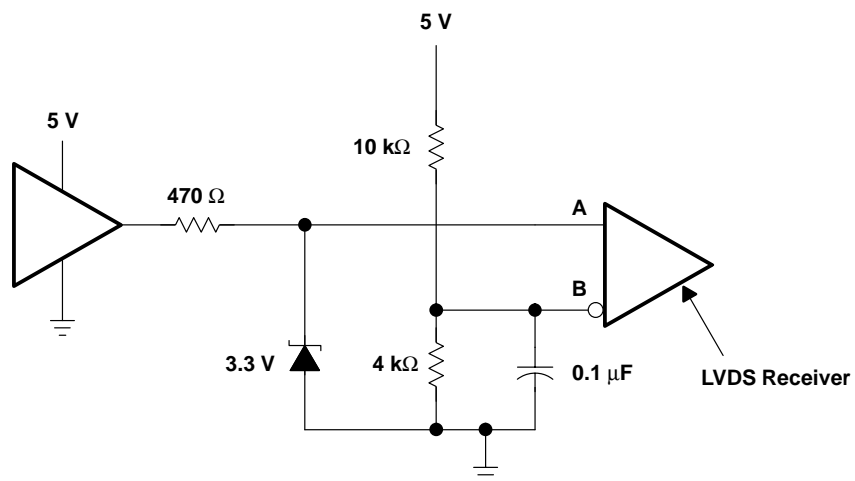

Figure 19. TTL

MECHANICAL DATA

DGG (R-PDSO-G**)

PLASTIC SMALL-OUTLINE PACKAGE

48 PINS SHOWN

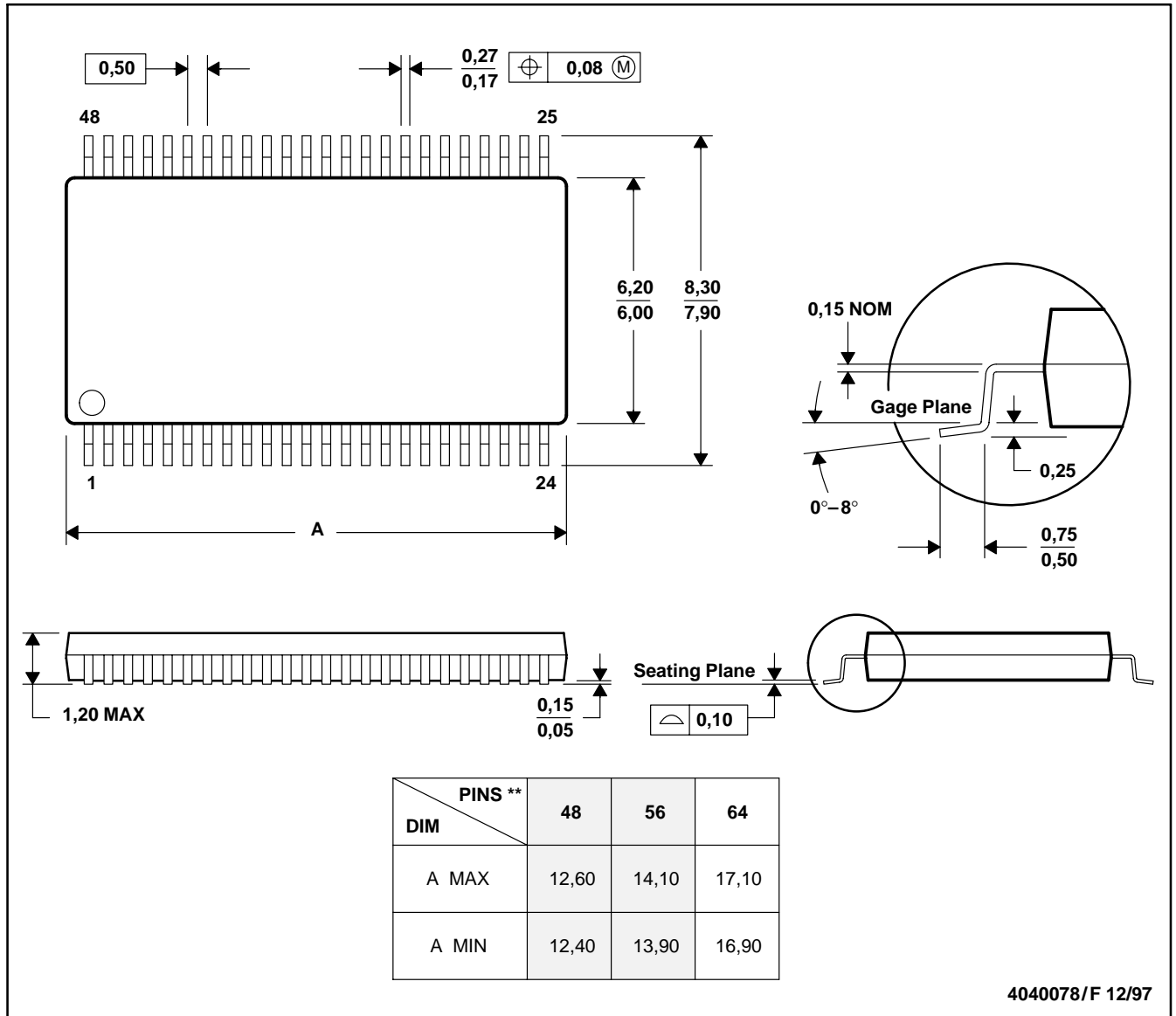

- NOTES: A. All linear dimensions are in millimeters.
 B. This drawing is subject to change without notice.
 C. Body dimensions do not include mold protrusion not to exceed 0,15.
 D. Falls within JEDEC MO-153

IMPORTANT NOTICE

Texas Instruments Incorporated and its subsidiaries (TI) reserve the right to make corrections, modifications, enhancements, improvements, and other changes to its products and services at any time and to discontinue any product or service without notice. Customers should obtain the latest relevant information before placing orders and should verify that such information is current and complete. All products are sold subject to TI's terms and conditions of sale supplied at the time of order acknowledgment.

TI warrants performance of its hardware products to the specifications applicable at the time of sale in accordance with TI's standard warranty. Testing and other quality control techniques are used to the extent TI deems necessary to support this warranty. Except where mandated by government requirements, testing of all parameters of each product is not necessarily performed.

TI assumes no liability for applications assistance or customer product design. Customers are responsible for their products and applications using TI components. To minimize the risks associated with customer products and applications, customers should provide adequate design and operating safeguards.

TI does not warrant or represent that any license, either express or implied, is granted under any TI patent right, copyright, mask work right, or other TI intellectual property right relating to any combination, machine, or process in which TI products or services are used. Information published by TI regarding third-party products or services does not constitute a license from TI to use such products or services or a warranty or endorsement thereof. Use of such information may require a license from a third party under the patents or other intellectual property of the third party, or a license from TI under the patents or other intellectual property of TI.

Reproduction of information in TI data books or data sheets is permissible only if reproduction is without alteration and is accompanied by all associated warranties, conditions, limitations, and notices. Reproduction of this information with alteration is an unfair and deceptive business practice. TI is not responsible or liable for such altered documentation.

Resale of TI products or services with statements different from or beyond the parameters stated by TI for that product or service voids all express and any implied warranties for the associated TI product or service and is an unfair and deceptive business practice. TI is not responsible or liable for any such statements.

Mailing Address:

Texas Instruments
Post Office Box 655303
Dallas, Texas 75265