

# SN65LVDS109, SN65LVDS117 DUAL 4-PORT AND DUAL 8-PORT LVDS REPEATERS

SLLS369E – AUGUST 1999 – REVISED MAY 2001

- Two Line Receivers and Eight ('109) or Sixteen ('117) Line Drivers Meet or Exceed the Requirements of ANSI EIA/TIA-644 Standard
- Designed for Signaling Rates up to 632 Mbps
- Outputs Arranged in Pairs From Each Bank
- Enabling Logic Allows Individual Control of Each Driver Output Pair, Plus All Outputs
- Low-Voltage Differential Signaling With Typical Output Voltage of 350 mV and a 100-Ω Load
- Electrically Compatible With LVDS, PECL, LVPECL, LVTTTL, LVCMOS, GTL, BTL, CTT, SSTL, or HSTL Outputs With External Termination Networks
- Propagation Delay Times < 4.5 ns
- Output Skew Less Than 550 ps  
Bank Skew Less Than 150 ps  
Part-to-Part Skew Less Than 1.5 ns
- Total Power Dissipation Typically < 500 mW With All Ports Enabled and at 200 MHz
- Driver Outputs or Receiver Input Equals High Impedance When Disabled or With  $V_{CC} < 1.5$  V
- Bus-Pin ESD Protection Exceeds 12 kV
- Packaged in Thin Shrink Small-Outline Package With 20 mil Terminal Pitch

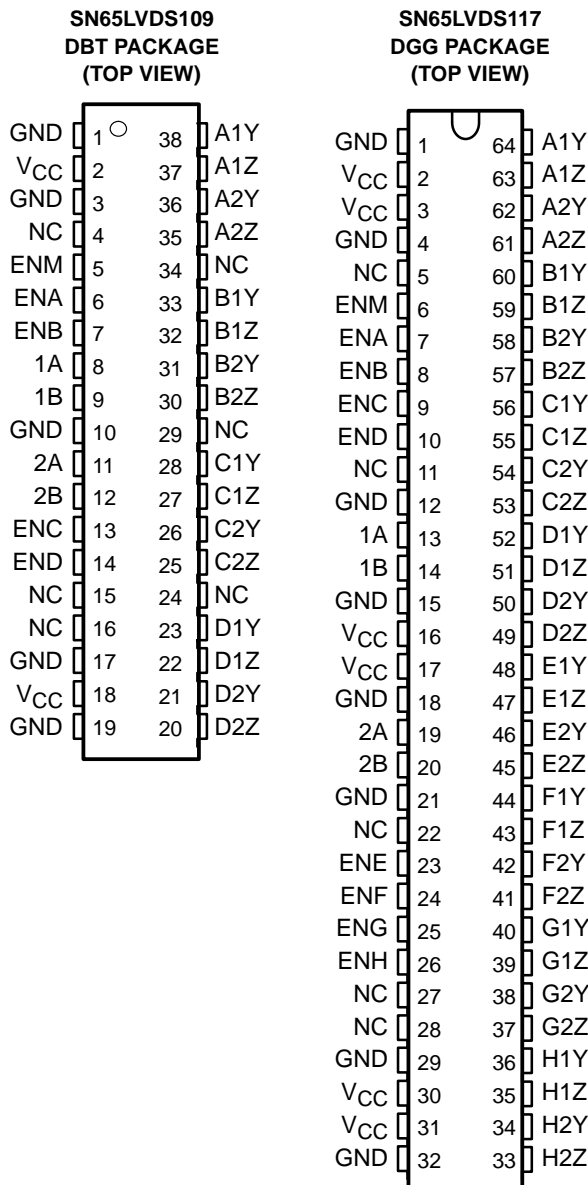

## description

The SN65LVDS109 and SN65LVDS117 are configured as two identical banks, each bank having one differential line receiver connected to either four ('109) or eight ('117) differential line drivers. The outputs are arranged in pairs having one output from each of the two banks. Individual output enables are provided for each pair of outputs and an additional enable is provided for all outputs.

The line receivers and line drivers implement the electrical characteristics of low-voltage differential signaling (LVDS). LVDS, as specified in EIA/TIA-644, is a data signaling technique that offers low power, low noise emission, high noise immunity, and high switching speeds. It can be used to transmit data at speeds up to at least 622 Mbps and over relatively long distances. (Note: The ultimate rate and distance of data transfer is dependent upon the attenuation characteristics of the media, the noise coupling to the environment, and other system characteristics.)



Please be aware that an important notice concerning availability, standard warranty, and use in critical applications of Texas Instruments semiconductor products and disclaimers thereto appears at the end of this data sheet.

PRODUCTION DATA information is current as of publication date. Products conform to specifications per the terms of Texas Instruments standard warranty. Production processing does not necessarily include testing of all parameters.

 **TEXAS  
INSTRUMENTS**

POST OFFICE BOX 655303 • DALLAS, TEXAS 75265

Copyright © 2001, Texas Instruments Incorporated

# SN65LVDS109, SN65LVDS117 DUAL 4-PORT AND DUAL 8-PORT LVDS REPEATERS

SLLS369E – AUGUST 1999 – REVISED MAY 2001

---

## **description (continued)**

The intended application of these devices, and the LVDS signaling technique, is for point-to-point or point-to-multipoint (distributed simplex) baseband data transmission on controlled impedance media of approximately 100  $\Omega$ . The transmission media may be printed-circuit board traces, backplanes, or cables. The large number of drivers integrated into the same silicon substrate, along with the low pulse skew of balanced signaling, provides extremely precise timing alignment of the signals being repeated from the inputs. This is particularly advantageous for implementing system clock and data distribution trees.

The SN65LVDS109 and SN65LVDS117 are characterized for operation from  $-40^{\circ}\text{C}$  to  $85^{\circ}\text{C}$ .



POST OFFICE BOX 655303 • DALLAS, TEXAS 75265

# SN65LVDS109, SN65LVDS117 DUAL 4-PORT AND DUAL 8-PORT LVDS REPEATERS

SLLS369E – AUGUST 1999 – REVISED MAY 2001

## logic diagram (positive logic)

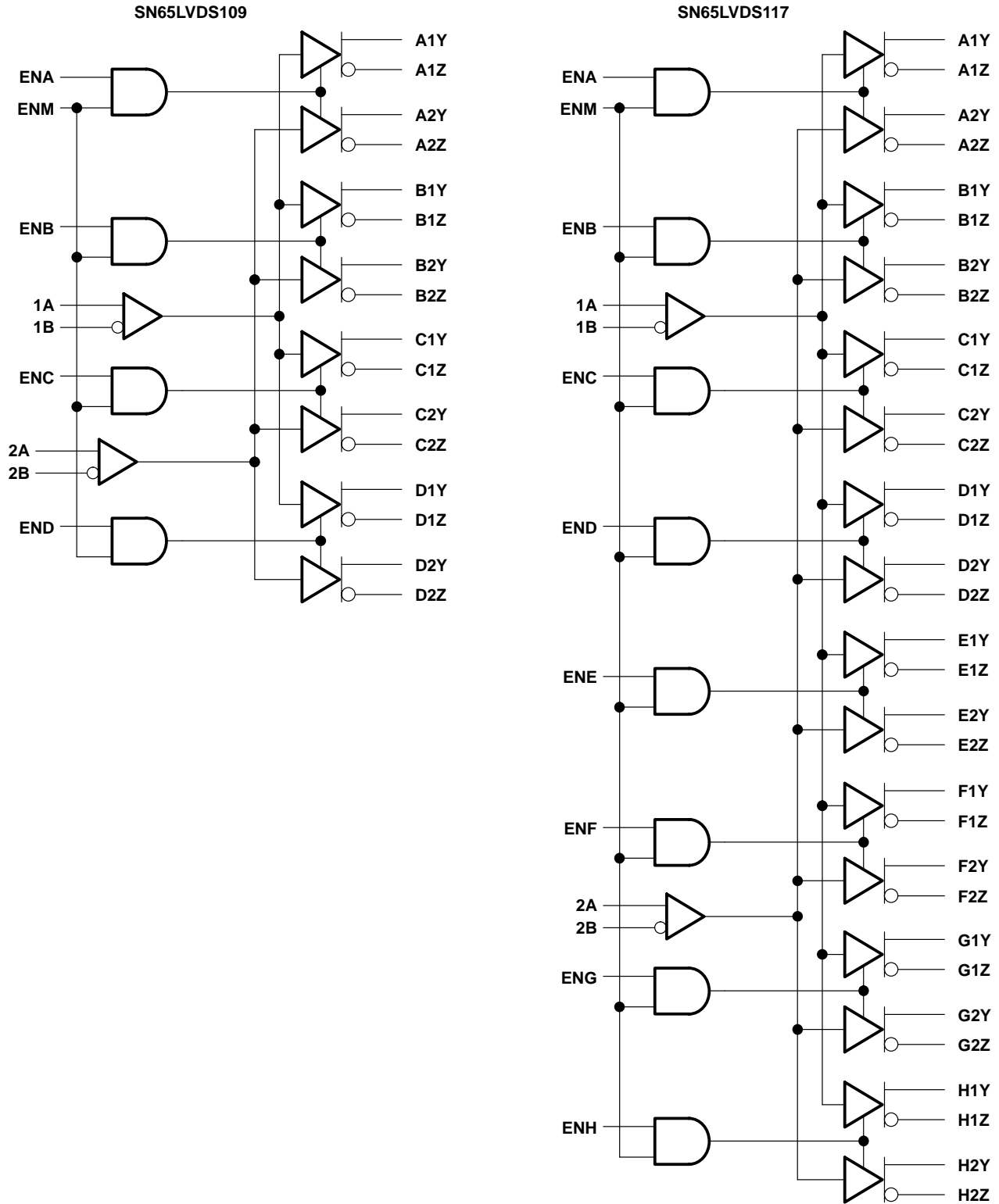

# SN65LVDS109, SN65LVDS117 DUAL 4-PORT AND DUAL 8-PORT LVDS REPEATERS

SLLS369E – AUGUST 1999 – REVISED MAY 2001

## selection guide to LVDS splitters

The SN65LVDS109 and SN75LVDS117 are both members of a family of LVDS splitters and repeaters. A brief overview of the family is provided by the following table.

LVDS SPLITTER AND REPEATER FAMILY

DEVICE	NUMBER OF INPUTS	NUMBER OF OUTPUTS	PACKAGE	COMMENTS
SN65LVDS104	1 LVDS	4 LVDS	16-pin D	4-Port LVDS repeater
SN65LVDS105	1 LVTTTL	4 LVDS	16-pin D	4-Port TTL-to-LVDS repeater
SN65LVDS108	1 LVDS	8 LVDS	38-pin DBT	8-Port LVDS repeater
SN65LVDS109	2 LVDS	8 LVDS	38-pin DBT	Dual 4-port LVDS repeater
SN65LVDS116	1 LVDS	16 LVDS	64-pin DGG	16-Port LVDS repeater
SN65LVDS117	2 LVDS	16 LVDS	64-pin DGG	Dual 8-Port LVDS repeater

FUNCTION TABLE

INPUTS	INPUTS		OUTPUTS	
	$V_{ID} = V_A - V_B$	ENM	ENx	$\overline{xY}$
X	L	X	Z	Z
X	X	L	Z	Z
$V_{ID} \geq 100 \text{ mV}$	H	H	H	L
$-100 \text{ mV} < V_{ID} < 100 \text{ mV}$	H	H	?	?
$V_{ID} \leq -100 \text{ mV}$	H	H	L	H

## equivalent input and output schematic diagrams

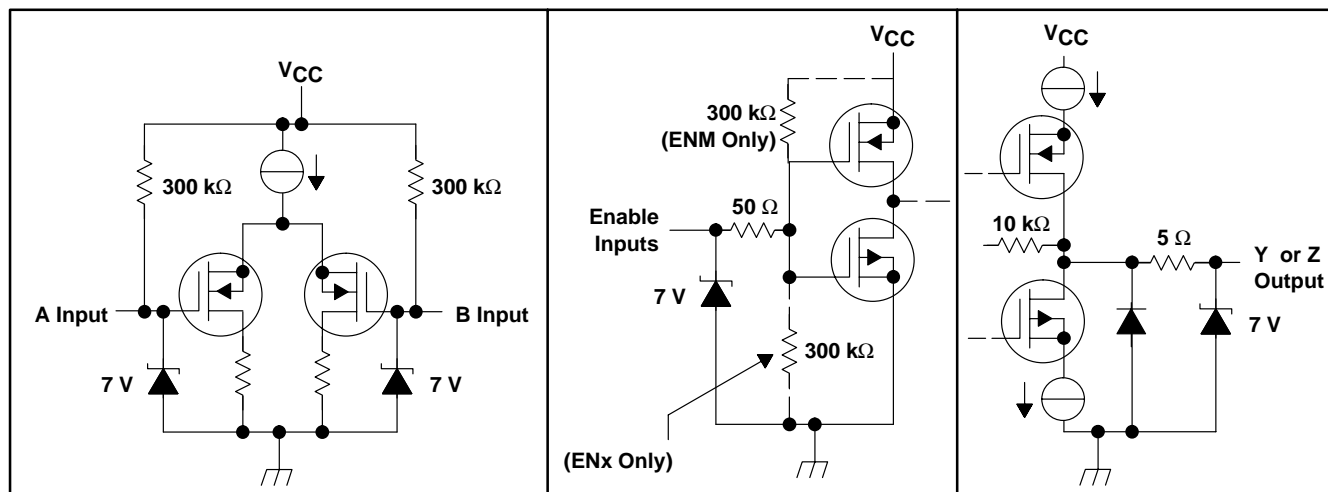

# SN65LVDS109, SN65LVDS117 DUAL 4-PORT AND DUAL 8-PORT LVDS REPEATERS

SLLS369E – AUGUST 1999 – REVISED MAY 2001

## absolute maximum ratings over operating free-air temperature (unless otherwise noted)†

Supply voltage range, $V_{CC}$ (see Note 1)	–0.5 V to 4 V
Input voltage range, Enable inputs	–0.5 V to 6 V
A, B, Y or Z	–0.5 V to 4 V
Electrostatic discharge, A, B, Y, Z, and GND (see Note 2)	Class 3, A:12 kV, B: 500 V
Continuous power dissipation	See Dissipation Rating Table
Storage temperature range	–65°C to 150°C
Lead temperature 1,6 mm (1/16 inch) from case for 10 seconds	260°C

† Stresses beyond those listed under “absolute maximum ratings” may cause permanent damage to the device. These are stress ratings only, and functional operation of the device at these or any other conditions beyond those indicated under “recommended operating conditions” is not implied. Exposure to absolute-maximum-rated conditions for extended periods may affect device reliability.

- NOTES: 1. All voltage values, except differential I/O bus voltages, are with respect to network ground terminal.  
2. Tested in accordance with MIL-STD-883C Method 3015.7.

**DISSIPATION RATING TABLE**

PACKAGE	$T_A \leq 25^\circ\text{C}$ POWER RATING	DERATING FACTOR‡ ABOVE $T_A = 25^\circ\text{C}$	$T_A = 85^\circ\text{C}$ POWER RATING
DBT	1277 mW	10.2 mW/°C	644 mW
DGG	2094 mW	16.7 mW/°C	1089 mW

‡ This is the inverse of the junction-to-ambient thermal resistance when board-mounted (low-k) with no air flow.

## recommended operating conditions

	MIN	NOM	MAX	UNIT
Supply voltage, $V_{CC}$	3	3.3	3.6	V
High-level input voltage, $V_{IH}$	2			V
Low-level input voltage, $V_{IL}$			0.8	V
Voltage at any bus terminal (separately or common-mode), $V_I$ or $V_{IC}$	0		$V_{CC} - 0.8$	V
Operating free-air temperature, $T_A$	–40		85	°C



# SN65LVDS109, SN65LVDS117 DUAL 4-PORT AND DUAL 8-PORT LVDS REPEATERS

SLLS369E – AUGUST 1999 – REVISED MAY 2001

## electrical characteristics over recommended operating conditions (unless otherwise noted)

PARAMETER		TEST CONDITIONS	MIN	TYP†	MAX	UNIT	
$V_{ITH+}$	Positive-going differential input voltage threshold	See Figure 1 and Table 1			100	mV	
$V_{ITH-}$	Negative-going differential input voltage threshold				-100		
$ V_{OD} $	Differential output voltage magnitude	$R_L = 100 \Omega$ , $V_{ID} = \pm 100 \text{ mV}$ , See Figures 1 and 2	247	340	454	mV	
$\Delta V_{OD} $	Change in differential output voltage magnitude between logic states				50		
$V_{OC(SS)}$	Steady-state common-mode output voltage	See Figure 3	1.125		1.375	V	
$\Delta V_{OC(SS)}$	Change in steady-state common-mode output voltage between logic states				50	mV	
$V_{OC(PP)}$	Peak-to-peak common-mode output voltage			50	150		
$I_{CC}$	Supply current	SN65LVDS109	Enabled, $R_L = 100 \Omega$		46	64	mA
			Disabled		6	8	
		SN65LVDS117	Enabled, $R_L = 100 \Omega$		85	122	
			Disabled		6	8	
$I_I$	Input current (A or B inputs)	$V_I = 0 \text{ V}$		-2	-20	$\mu\text{A}$	
		$V_I = 2.4 \text{ V}$		-1.2			
$I_{I(OFF)}$	Power-off input current (A or B inputs)	$V_{CC} = 1.5 \text{ V}$ , $V_I = 2.4 \text{ V}$			20	$\mu\text{A}$	
$I_{IH}$	High-level input current (enables)	$V_{IH} = 2 \text{ V}$			20	$\mu\text{A}$	
$I_{IL}$	Low-level input current (enables)	$V_{IL} = 0.8 \text{ V}$			10	$\mu\text{A}$	
$I_{OS}$	Short-circuit output current	$V_{OY}$ or $V_{OZ} = 0 \text{ V}$			$\pm 24$	mA	
		$V_{OD} = 0 \text{ V}$			$\pm 12$		
$I_{OZ}$	High-impedance output current	$V_O = 0 \text{ V}$ or $V_{CC}$			$\pm 1$	$\mu\text{A}$	
$I_{O(OFF)}$	Power-off output current	$V_{CC} = 1.5 \text{ V}$ , $V_O = 3.6 \text{ V}$			$\pm 1$	$\mu\text{A}$	
$C_{IN}$	Input capacitance (A or B inputs)	$V_I = 0.4 \sin(4E6\pi t) + 0.5 \text{ V}$		5		pF	
$C_O$	Output capacitance (Y or Z outputs)	$V_I = 0.4 \sin(4E6\pi t) + 0.5 \text{ V}$ , Disabled		9.4			

† All typical values are at 25°C and with a 3.3-V supply.



# SN65LVDS109, SN65LVDS117 DUAL 4-PORT AND DUAL 8-PORT LVDS REPEATERS

SLLS369E – AUGUST 1999 – REVISED MAY 2001

## switching characteristics over recommended operating conditions (unless otherwise noted)

PARAMETER		TEST CONDITIONS	MIN	TYP†	MAX	UNIT
t <sub>PLH</sub>	Propagation delay time, low-to-high-level output	R <sub>L</sub> = 100 Ω, C <sub>L</sub> = 10 pF, See Figure 4	1.6	2.8	4.5	ns
t <sub>PHL</sub>	Propagation delay time, high-to-low-level output		1.6	2.8	4.5	
t <sub>r</sub>	Differential output signal rise time		0.3	0.8	1.2	ns
t <sub>f</sub>	Differential output signal fall time		0.3	0.8	1.2	
t <sub>sk(p)</sub>	Pulse skew ( t <sub>PHL</sub> - t <sub>PLH</sub>  )‡			140	500	ps
t <sub>sk(o)</sub>	Output skew§			100	550	
t <sub>sk(b)</sub>	Bank skew¶			40	150	ps
t <sub>sk(pp)</sub>	Part-to-part skew#			1.5	ns	
t <sub>PZH</sub>	Propagation delay time, high-impedance-to-high-level output	See Figure 5		5.7	15	ns
t <sub>PZL</sub>	Propagation delay time, high-impedance-to-low-level output			7.7	15	
t <sub>PHZ</sub>	Propagation delay time, high-level-to-high-impedance output			3.2	15	ns
t <sub>PLZ</sub>	Propagation delay time, low-level-to-high-impedance output			3.2	15	

† All typical values are at 25°C and with a 3.3-V supply.

‡ t<sub>sk(p)</sub> is the magnitude of the time difference between the t<sub>PLH</sub> and t<sub>PHL</sub> of any output of a single device.

§ t<sub>sk(o)</sub> is the magnitude of the time difference between the t<sub>PLH</sub> or t<sub>PHL</sub> of any outputs with both inputs tied together.

¶ t<sub>sk(b)</sub> is the magnitude of the time difference between the t<sub>PLH</sub> and t<sub>PHL</sub> of the two outputs of any bank of a single device.

# t<sub>sk(pp)</sub> is the magnitude of the time difference in propagation delay times between any specified terminals of two devices when both devices operate with the same supply voltages, at the same temperature, and have identical packages and test circuits.

## PARAMETER MEASUREMENT INFORMATION

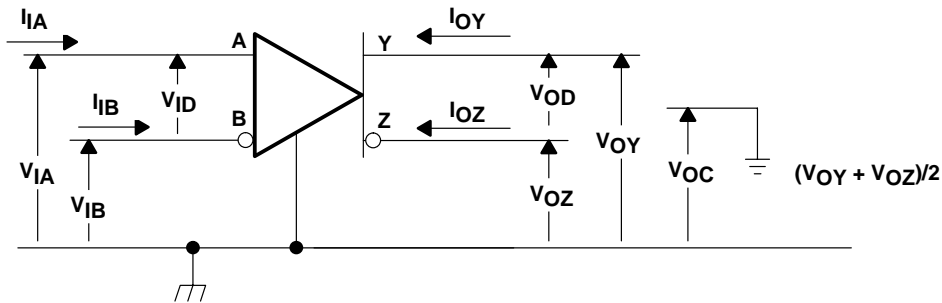

Figure 1. Voltage and Current Definitions

# SN65LVDS109, SN65LVDS117 DUAL 4-PORT AND DUAL 8-PORT LVDS REPEATERS

SLLS369E – AUGUST 1999 – REVISED MAY 2001

## PARAMETER MEASUREMENT INFORMATION

Table 1. Receiver Minimum and Maximum Input Threshold Test Voltages

APPLIED VOLTAGES		RESULTING DIFFERENTIAL INPUT VOLTAGE	RESULTING COMMON-MODE INPUT VOLTAGE
$V_{IA}$	$V_{IB}$	$V_{ID}$	$V_{IC}$
1.25 V	1.15 V	100 mV	1.2 V
1.15 V	1.25 V	-100 mV	1.2 V
2.4 V	2.3 V	100 mV	2.35 V
2.3 V	2.4 V	-100 mV	2.35 V
0.1 V	0 V	100 mV	0.05 V
0 V	0.1 V	-100 mV	0.05 V
1.5 V	0.9 V	600 mV	1.2 V
0.9 V	1.5 V	-600 mV	1.2 V
2.4 V	1.8 V	600 mV	2.1 V
1.8 V	2.4 V	-600 mV	2.1 V
0.6 V	0 V	600 mV	0.3 V
0 V	0.6 V	-600 mV	0.3 V

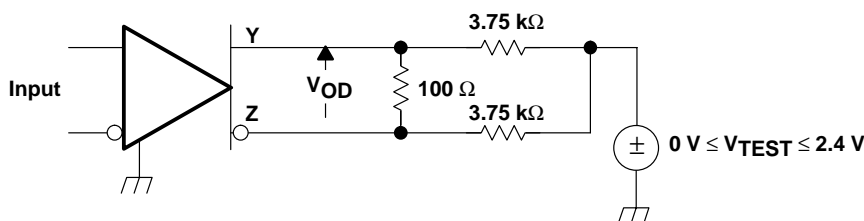
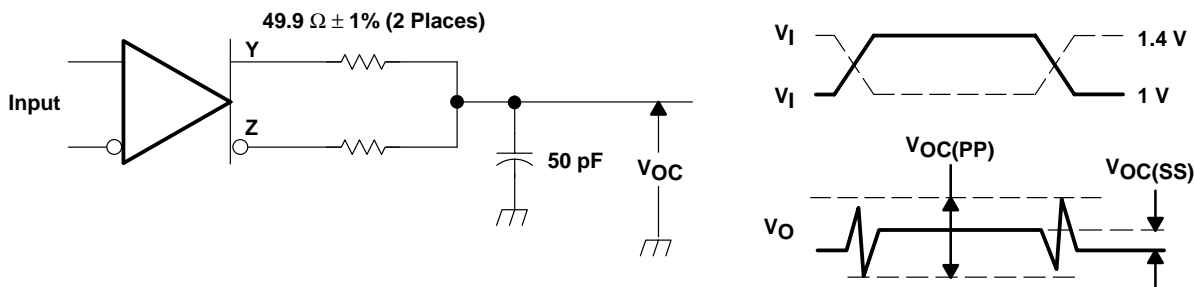

Figure 2. VOD Test Circuit



NOTE A: All input pulses are supplied by a generator having the following characteristics:  $t_r$  or  $t_f \leq 1$  ns, pulse repetition rate (PRR) = 0.5 Mpps, pulsewidth =  $500 \pm 10$  ns.  $C_L$  includes instrumentation and fixture capacitance within 0,06 mm of the D.U.T. The measurement of  $V_{OC(PP)}$  is made on test equipment with a -3 dB bandwidth of at least 300 MHz.

Figure 3. Test Circuit and Definitions for the Driver Common-Mode Output Voltage

PARAMETER MEASUREMENT INFORMATION

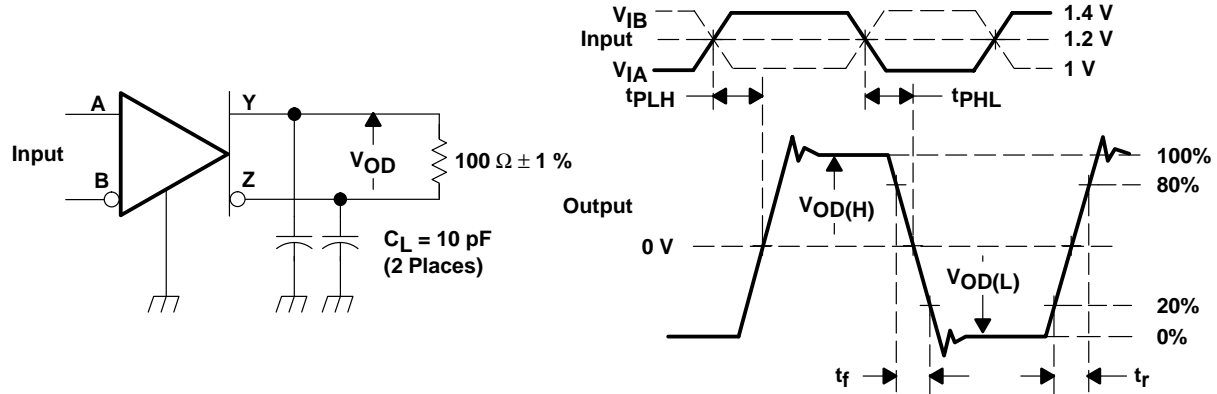

NOTE A: All input pulses are supplied by a generator having the following characteristics:  $t_r$  or  $t_f \leq 1$  ns, pulse repetition rate (PRR) = 50 Mpps, pulsewidth =  $10 \pm 0.2$  ns.  $C_L$  includes instrumentation and fixture capacitance within 0,06 mm of the D.U.T.

Figure 4. Test Circuit, Timing, and Voltage Definitions for the Differential Output Signal

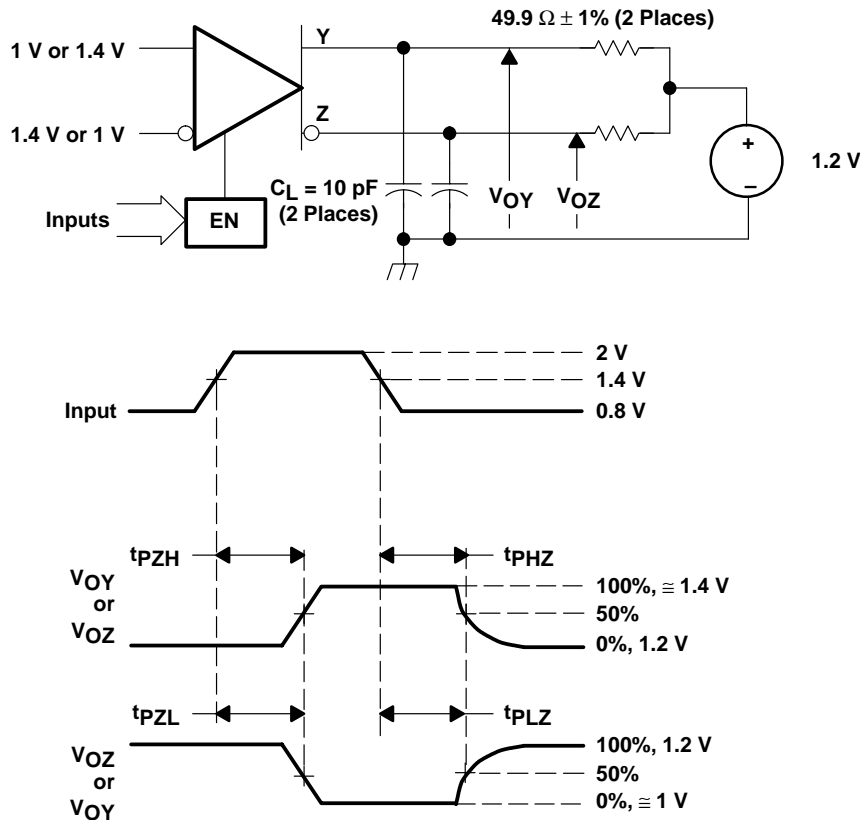

NOTE A: All input pulses are supplied by a generator having the following characteristics:  $t_r$  or  $t_f \leq 1$  ns, pulse repetition rate (PRR) = 0.5 Mpps, pulsewidth =  $500 \pm 10$  ns.  $C_L$  includes instrumentation and fixture capacitance within 0,06 mm of the D.U.T.

Figure 5. Enable and Disable Time Circuit and Definitions

# SN65LVDS109, SN65LVDS117 DUAL 4-PORT AND DUAL 8-PORT LVDS REPEATERS

SLLS369E – AUGUST 1999 – REVISED MAY 2001

## TYPICAL CHARACTERISTICS

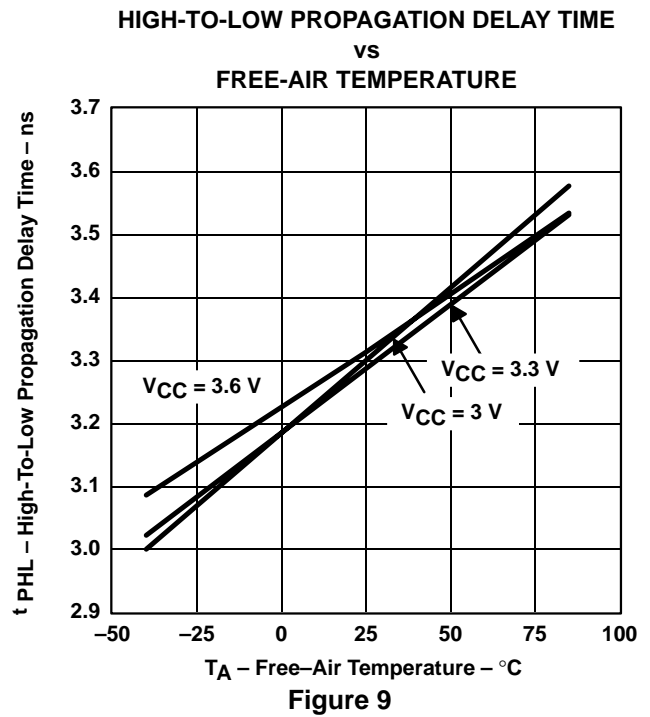
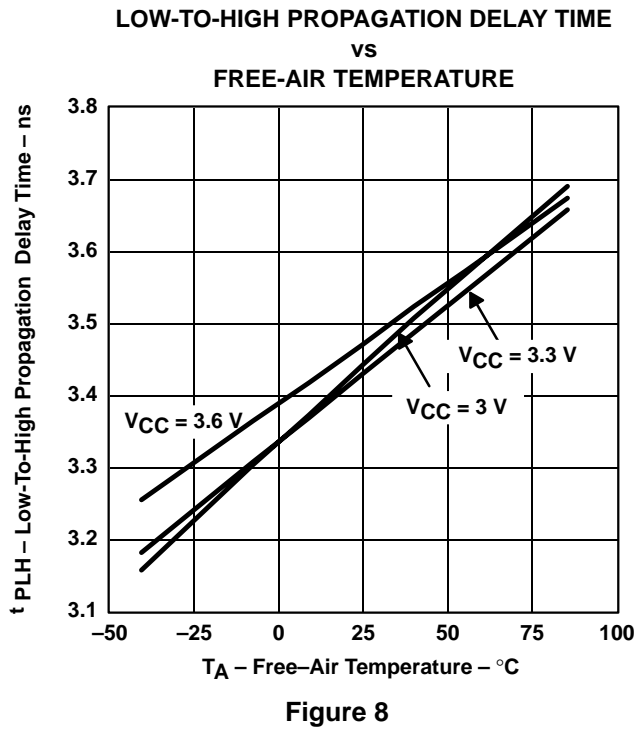
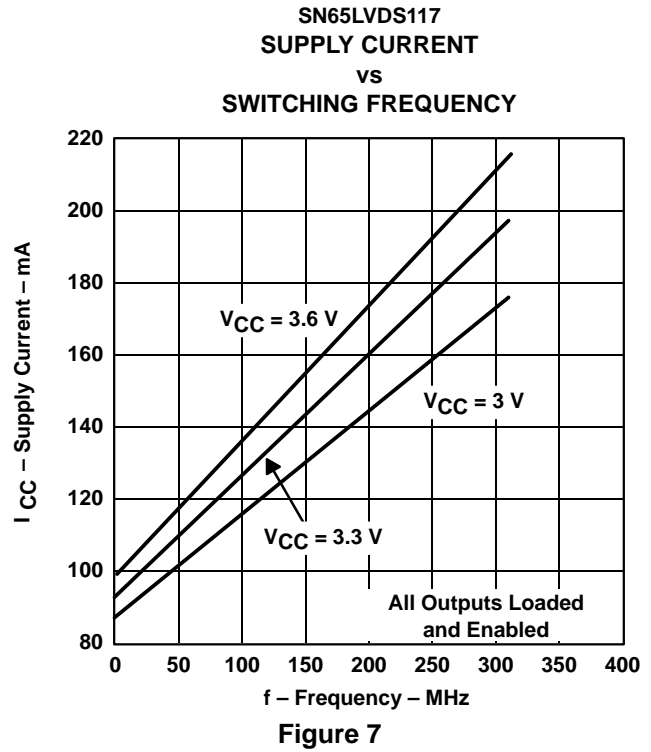
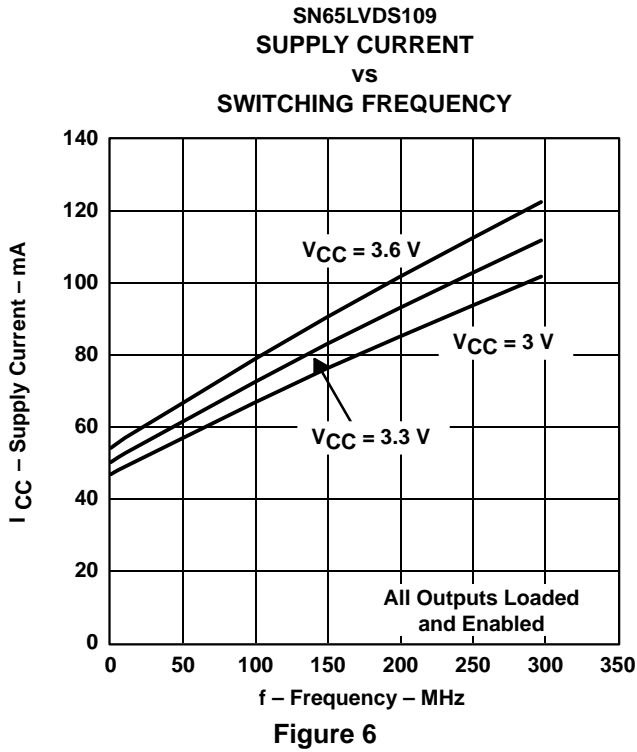

---

### TYPICAL CHARACTERISTICS

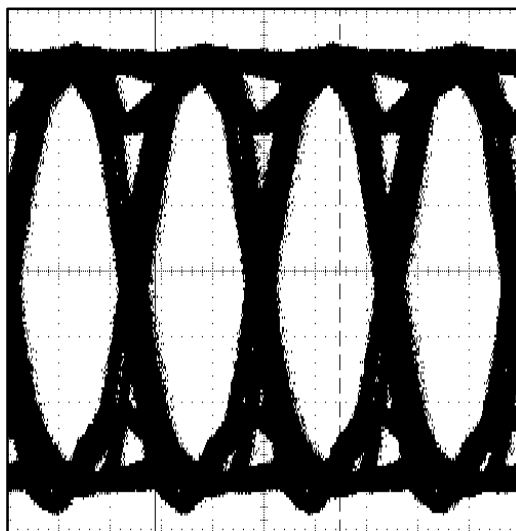

Figure 10. Typical Differential Eye Pattern at 400 Mbps

---

### APPLICATION INFORMATION

The SN65LVDS109 and SN65LVDS117 devices solve several problems common to the distribution of timing critical clock and data signals. These problems include:

- Excessive skew between the signals
- Noise pickup over long signaling paths
- High power consumption
- Control of which signal paths are enabled or disabled
- Elimination of radiation from unterminated lines

Buffering and splitting the two related signals on the same silicon die minimizes corruption of the timing relation between the two signals. Buffering and splitting the two signals in separate devices will introduce considerably higher levels of uncontrolled timing skew between the two signals. Higher speed operation and more timing tolerance for other components of the system is enabled by the tighter system timing budgets provided by the single die implementations of the SN65LVDS109 and SN65LVDS117.

The use of LVDS signaling technology for both the inputs and the outputs provides superior common-mode and noise tolerance compared to single-ended I/O technologies. This is particularly important because the signals that are being distributed must be transmitted over longer distances, and at higher rates, than can be accommodated with single-ended I/Os. In addition, LVDS consumes considerably less power than other high-performance differential signaling schemes.

The enable inputs provided for each output pair may be used to turn on or off any of the paths. This function is required to prevent radiation of signals from the unterminated signal lines on open connectors, such as when boards or devices are being swapped in the end equipment. The individual bank enables are also required if redundant paths are being utilized for reliability reasons.

# SN65LVDS109, SN65LVDS117 DUAL 4-PORT AND DUAL 8-PORT LVDS REPEATERS

SLLS369E – AUGUST 1999 – REVISED MAY 2001

## APPLICATION INFORMATION

The diagram below shows how a pair of clock (C) and data (D) input signals is being identically repeated out two of the available output pairs. A third output pair is shown in the disabled state.

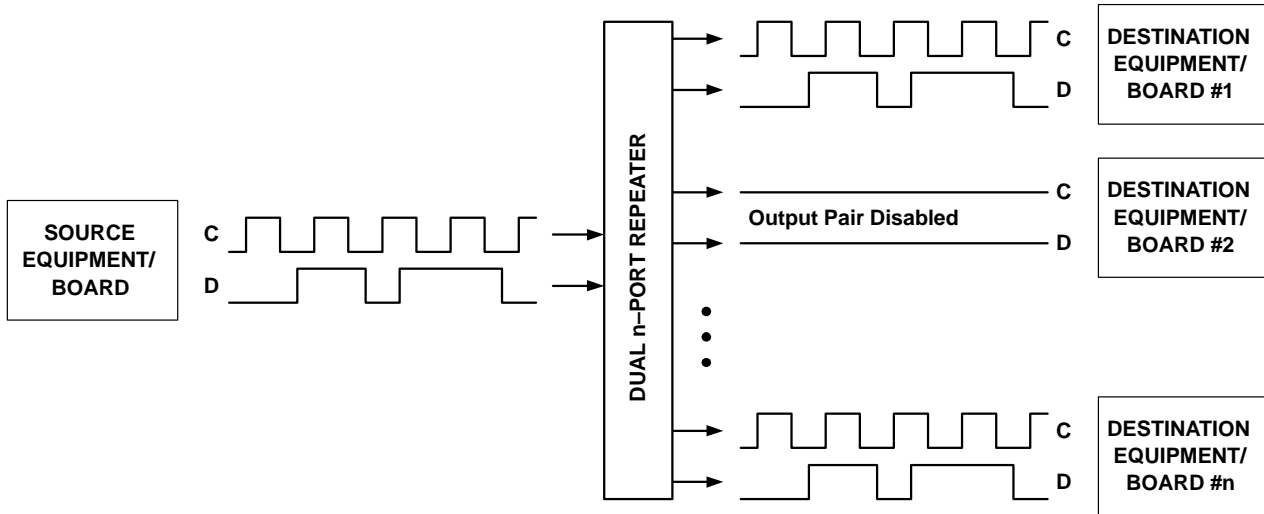

Figure 11. LVDS Repeating Splitter Application Example Showing Individual Path Control

A LVDS receiver can be used to receive various other types of logic signals. Figure 12 through Figure 20 show the termination circuits for SSTL, HSTL, GTL, BTL, LVPECL, PECL, CMOS, and TTL.

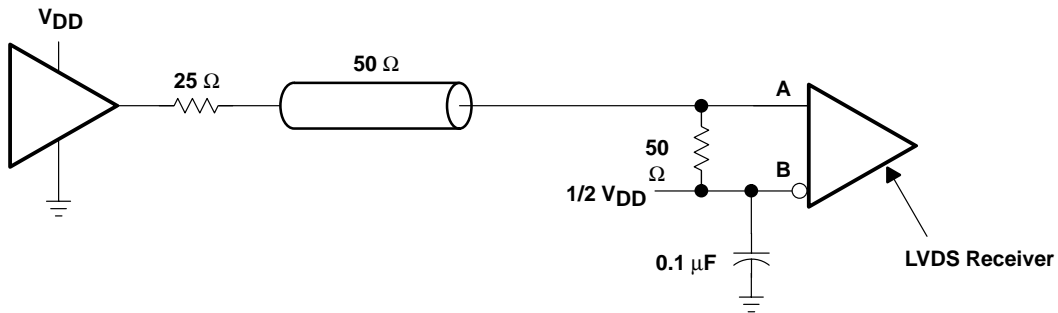

Figure 12. Stub-Series Terminated (SSTL) or High-Speed Transceiver Logic (HSTL)

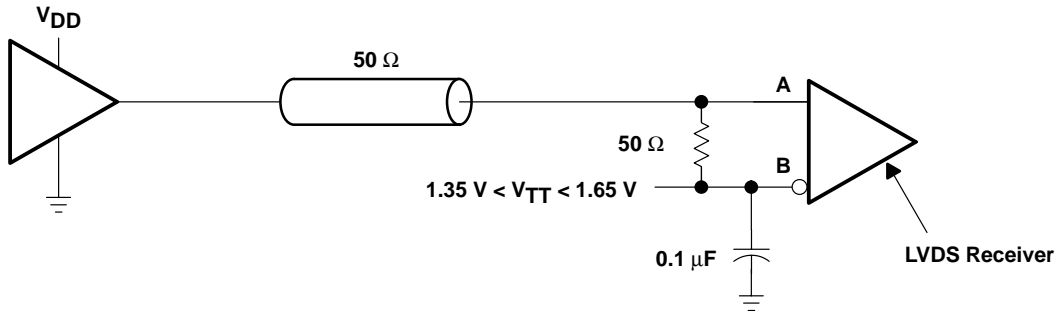

Figure 13. Center-Tap Termination (CTT)

APPLICATION INFORMATION

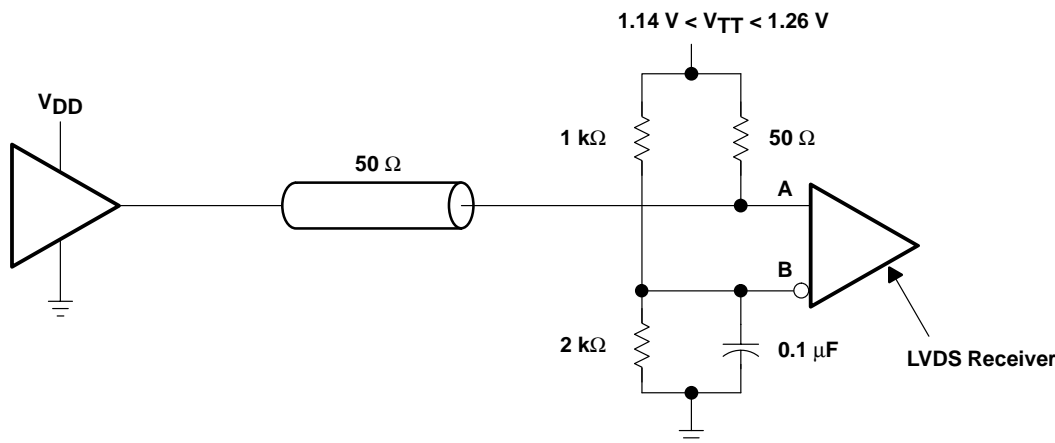

Figure 14. Gunning Transceiver Logic (GTL)

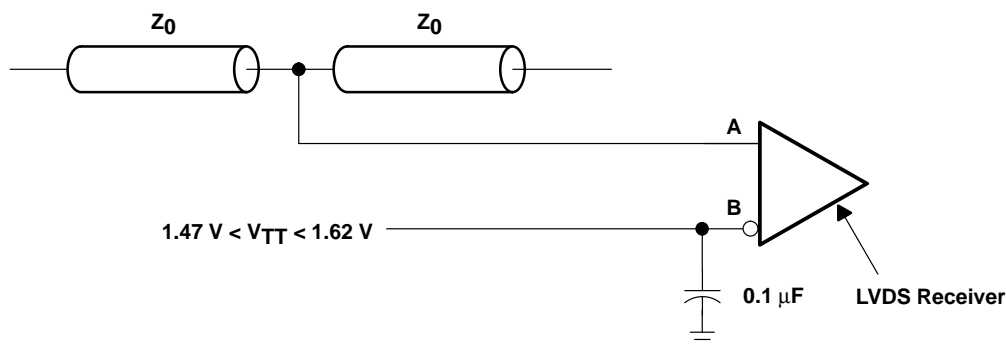

Figure 15. Backplane Transceiver Logic (BTL)

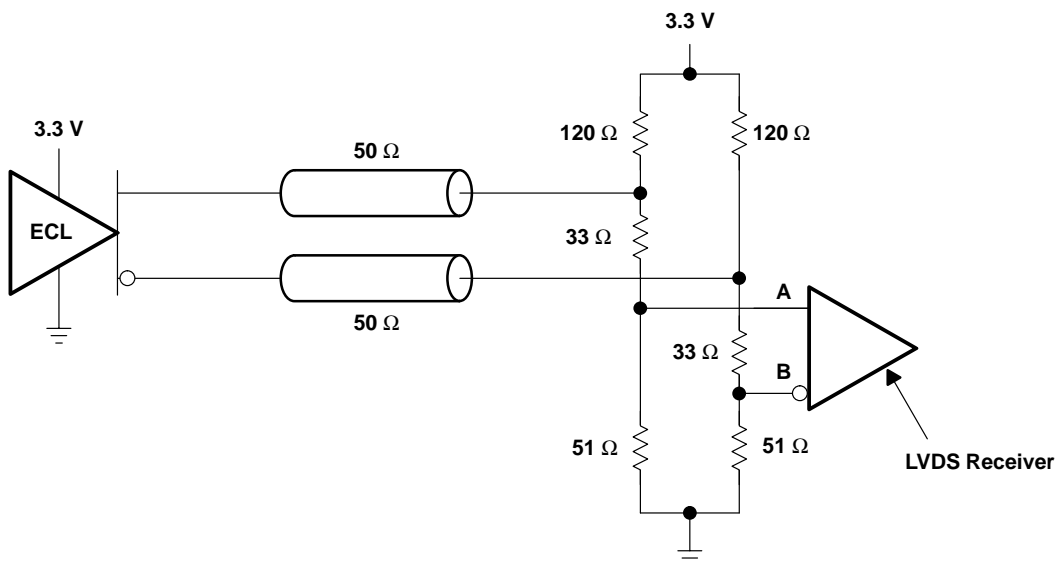

Figure 16. Low-Voltage Positive Emitter-Coupled Logic (LVPECL)

# SN65LVDS109, SN65LVDS117 DUAL 4-PORT AND DUAL 8-PORT LVDS REPEATERS

SLLS369E – AUGUST 1999 – REVISED MAY 2001

## APPLICATION INFORMATION

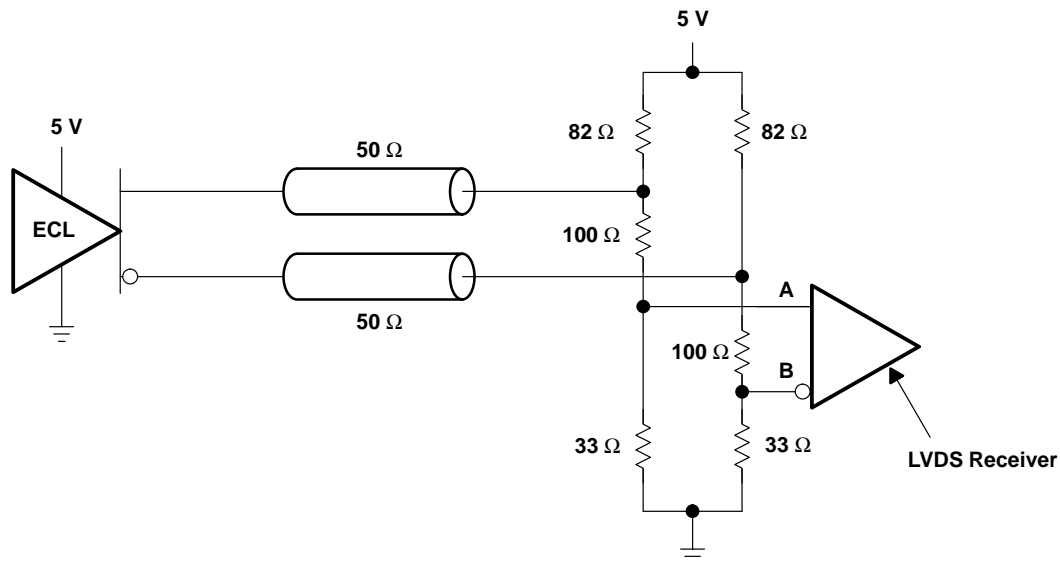

Figure 17. Positive Emitter-Coupled Logic (PECL)

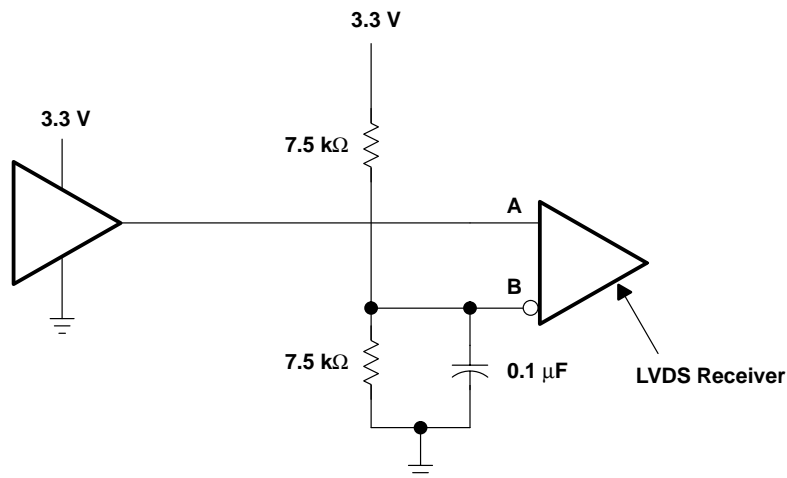

Figure 18. 3.3-V CMOS

APPLICATION INFORMATION

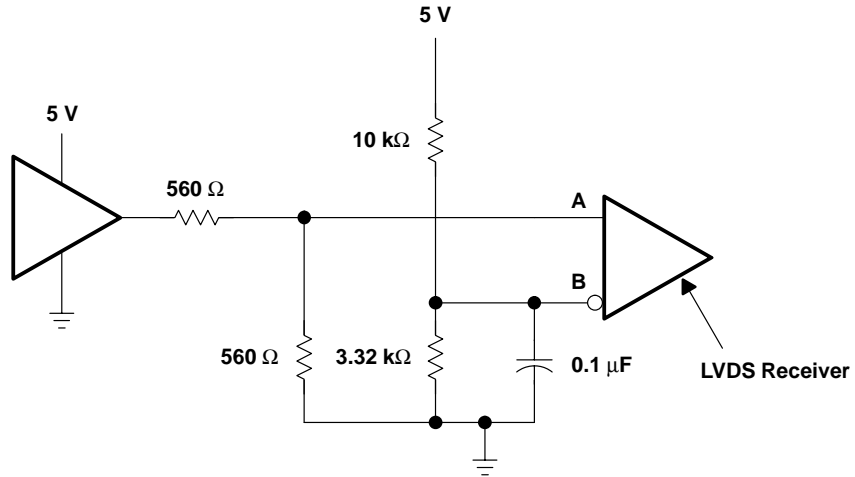

Figure 19. 5-V CMOS

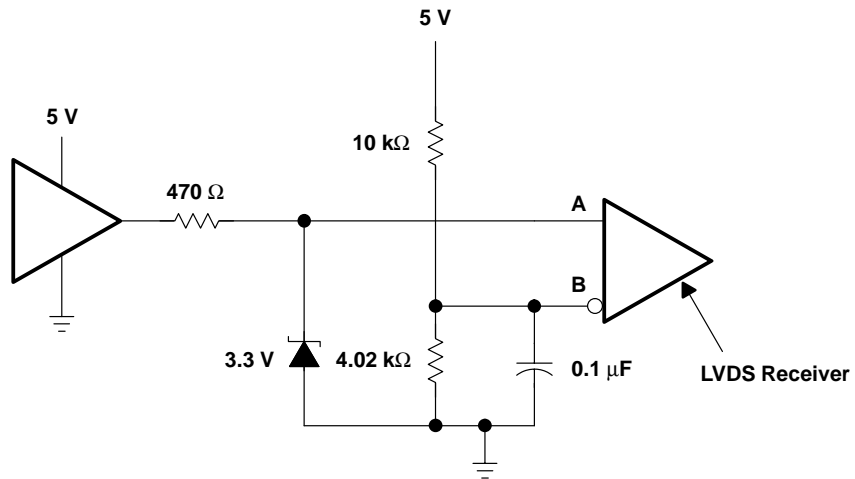

Figure 20. TTL

# SN65LVDS109, SN65LVDS117 DUAL 4-PORT AND DUAL 8-PORT LVDS REPEATERS

SLLS369E – AUGUST 1999 – REVISED MAY 2001

## MECHANICAL DATA

DBT (R-PDSO-G\*\*)

PLASTIC SMALL-OUTLINE PACKAGE

30 PINS SHOWN

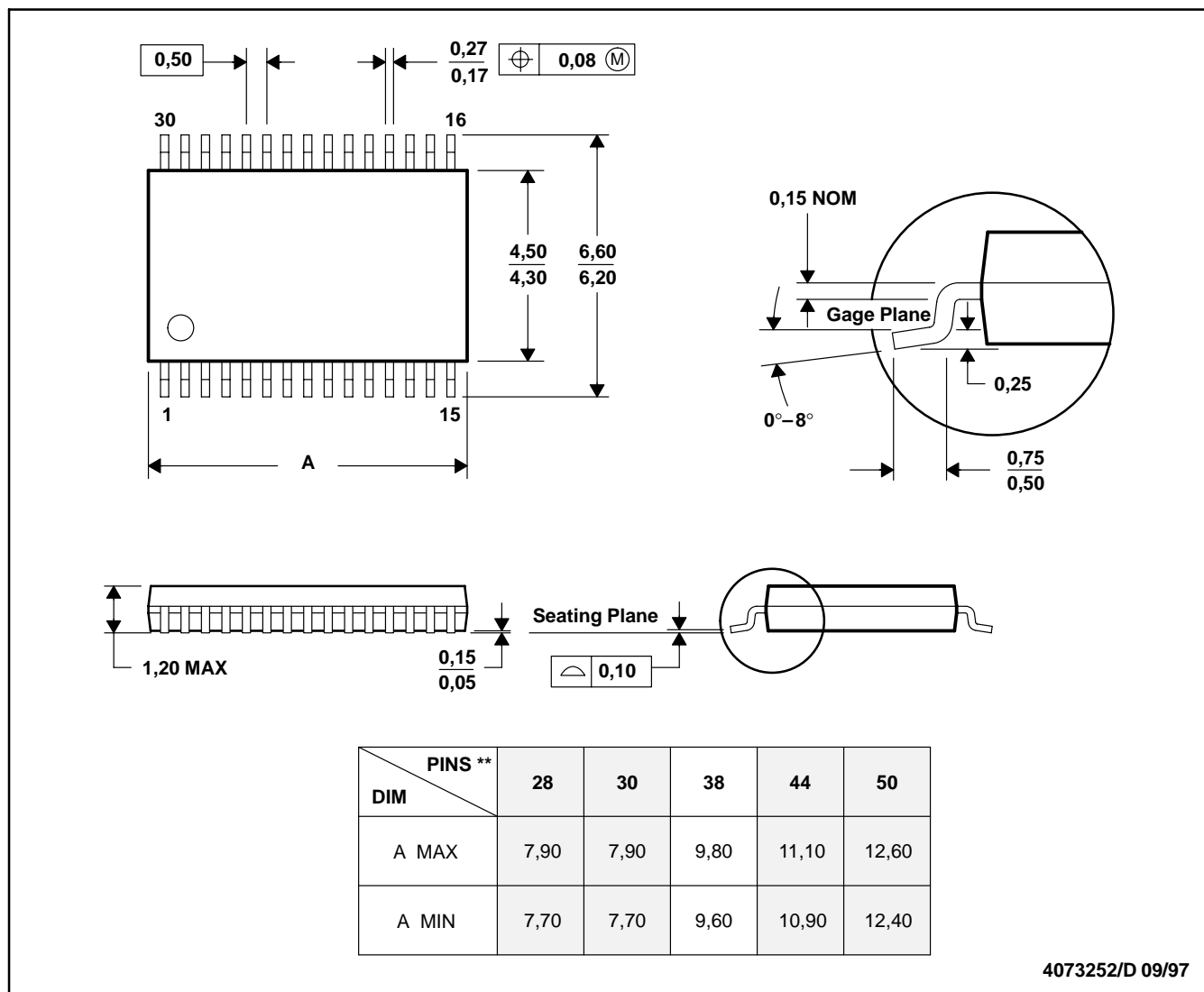

- NOTES:
- A. All linear dimensions are in millimeters.
  - B. This drawing is subject to change without notice.
  - C. Body dimensions do not include mold flash or protrusion.
  - D. Falls within JEDEC MO-153



## IMPORTANT NOTICE

Texas Instruments and its subsidiaries (TI) reserve the right to make changes to their products or to discontinue any product or service without notice, and advise customers to obtain the latest version of relevant information to verify, before placing orders, that information being relied on is current and complete. All products are sold subject to the terms and conditions of sale supplied at the time of order acknowledgment, including those pertaining to warranty, patent infringement, and limitation of liability.

TI warrants performance of its products to the specifications applicable at the time of sale in accordance with TI's standard warranty. Testing and other quality control techniques are utilized to the extent TI deems necessary to support this warranty. Specific testing of all parameters of each device is not necessarily performed, except those mandated by government requirements.

Customers are responsible for their applications using TI components.

In order to minimize risks associated with the customer's applications, adequate design and operating safeguards must be provided by the customer to minimize inherent or procedural hazards.

TI assumes no liability for applications assistance or customer product design. TI does not warrant or represent that any license, either express or implied, is granted under any patent right, copyright, mask work right, or other intellectual property right of TI covering or relating to any combination, machine, or process in which such products or services might be or are used. TI's publication of information regarding any third party's products or services does not constitute TI's approval, license, warranty or endorsement thereof.

Reproduction of information in TI data books or data sheets is permissible only if reproduction is without alteration and is accompanied by all associated warranties, conditions, limitations and notices. Representation or reproduction of this information with alteration voids all warranties provided for an associated TI product or service, is an unfair and deceptive business practice, and TI is not responsible nor liable for any such use.

Resale of TI's products or services with statements different from or beyond the parameters stated by TI for that product or service voids all express and any implied warranties for the associated TI product or service, is an unfair and deceptive business practice, and TI is not responsible nor liable for any such use.

Also see: [Standard Terms and Conditions of Sale for Semiconductor Products](http://www.ti.com/sc/docs/stdterms.htm). [www.ti.com/sc/docs/stdterms.htm](http://www.ti.com/sc/docs/stdterms.htm)

### Mailing Address:

Texas Instruments  
Post Office Box 655303  
Dallas, Texas 75265