

- **A Member of the MuxIt™ Serializer-Deserializer Building-Block Chip Family**
- **Pin Selectable Frequency Multiplier Ratios Between 4 and 40**
- **Input Clock Frequencies From 5 to 50 MHz**
- **Multiplied Clock Frequencies up to 400 MHz**
- **Internal Loop Filters and Low PLL-Jitter of 20 ps RMS Typical at 200 MHz**
- **LVDS Compatible Differential Inputs and Outputs Meet or Exceed the Requirements of ANSI EIA/TIA-644-A**
- **LVTTTL Compatible Inputs Are 5 V Tolerant**
- **LVDS Inputs and Outputs ESD Protection Exceeds 12 kV HBM**
- **Operates From a Single 3.3 V Supply**
- **Packaged in 28-Pin Thin Shrink Small-Outline Package With 26 mil Terminal Pitch**

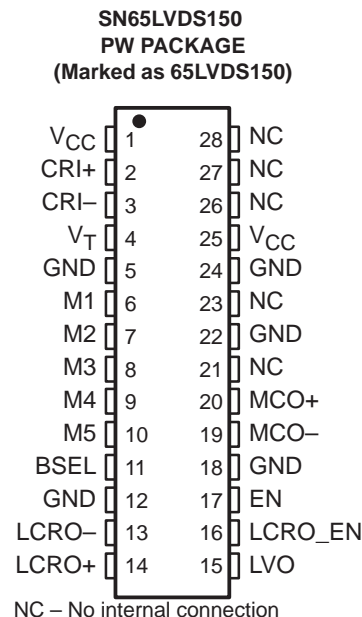

description

The MuxIt is a family of general-purpose, multiple-chip building blocks for implementing parallel data serializers and deserializers. The system allows for wide parallel data to be transmitted through a reduced number of differential transmission lines over distances greater than can be achieved with a single-ended (e.g., LVTTTL or LVCMOS) data interface. The number of bits multiplexed per transmission line is user selectable, allowing for higher transmission efficiencies than with other existing fixed ratio solutions. MuxIt utilizes the LVDS (TIA/EIA-644) low voltage differential signaling technology for communications between the data source and data destination.

The MuxIt family initially includes three devices supporting simplex communications; *The SN65LVDS150 Phase Locked Loop-Frequency Multiplier*, *The SN65LVDS151 Serializer-Transmitter*, and *The SN65LVDS152 Receiver-Deserializer*.

The SN65LVDS150 is a PLL based frequency multiplier designed for use with the other members of the MuxIt family of serializers and deserializers. The frequency multiplication ratio is pin selectable over a wide range of values from 4 through 40 to accommodate a broad spectrum of user needs. No external filter components are needed. A PLL lock indicator output is available which may be used to enable link data transfers.



Please be aware that an important notice concerning availability, standard warranty, and use in critical applications of Texas Instruments semiconductor products and disclaimers thereto appears at the end of this data sheet.

MuxIt is a trademark of Texas Instruments.

PRODUCTION DATA information is current as of publication date. Products conform to specifications per the terms of Texas Instruments standard warranty. Production processing does not necessarily include testing of all parameters.



POST OFFICE BOX 655303 • DALLAS, TEXAS 75265

Copyright © 2000, Texas Instruments Incorporated

SN65LVDS150

MuxIt™ PLL FREQUENCY MULTIPLIER

SLLS443 – DECEMBER 2000

description (continued)

The design of the SN65LVDS150 allows it to be used at either the transmit end or the receive end of the MuxIt serial link. The differential clock reference input (CRI) is driven by the system's parallel data clock when at the source end of the link, or by the link clock when at the destination end of the link. The differential clock reference input may be driven by either an LVDS differential signal, or by a single ended clock of either polarity. For single-ended use the nonclocked input is biased to the logic threshold voltage. A $V_{CC}/2$ threshold reference, VT, is provided on a pin adjacent the differential CRI pins for convenience when the input is used in a single-ended mode.

The multiplied clock output (MCO) is an LVDS differential signal used to drive the high-speed shift registers in either the SN65LVDS151 serializer-transmitter or the SN65LVDS152 receiver-deserializer. The link clock reference output (LCRO) is an LVDS differential signal provided to the SN65LVDS151 serializer-transmitter for transmission over the link.

An internal power on reset and an enable input (EN) control the operation of the SN65LVDS150. When V_{CC} is below 1.5 V, or when EN is low, the device is in a low power disabled state and the MCO and LCRO differential outputs are in a high-impedance state. When V_{CC} is above 3 V and EN is high, the device and the two differential outputs are enabled and operating to specifications. The link clock reference output enable input (LCRO_EN) is used to turn off the LCRO output when it is not being used. A band select input (BSEL) is used to optimize the VCO performance as a function of M-clock frequencies and M multiplier that is being used: The f_{max} parameter in the switching characteristic table includes details on the MCO frequency and choices of BSEL and M.

block diagram

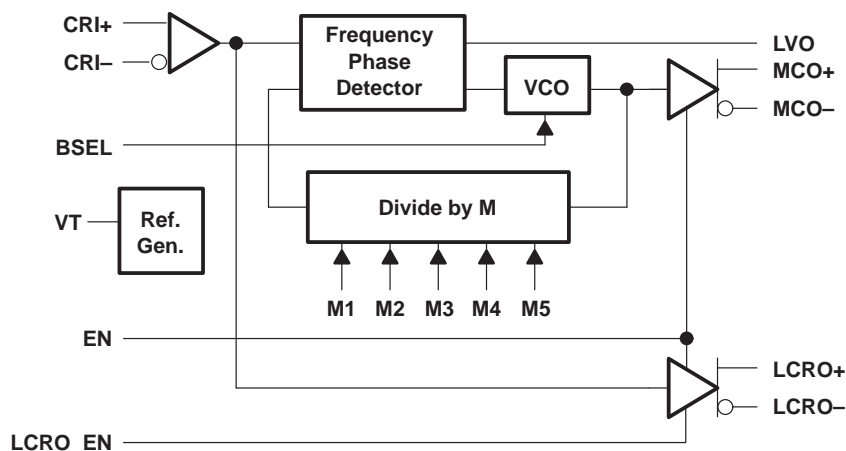

frequency multiplier value table

MULTIPLIER (m)	M1	M2	M3	M4	M5	RECOMMENDED f_{IN} (MHz)	
						BSEL = 0	BSEL = 1
4	L	L	L	L	L	$f_{IN} < 12.50$	$12.50 \leq f_{IN}$
†	L	L	L	L	H	NA	NA
6	L	L	L	H	L	$f_{IN} < 8.33$	$8.33 \leq f_{IN}$
†	L	L	L	H	H	NA	NA
8	L	L	H	L	L	$f_{IN} < 12.50$	$12.50 \leq f_{IN}$
9	L	L	H	L	H	$f_{IN} < 11.11$	$11.11 \leq f_{IN}$
10	L	L	H	H	L	$f_{IN} < 10.00$	$10.00 \leq f_{IN}$
†	L	L	H	H	H	NA	NA
12	L	H	L	L	L	$f_{IN} < 8.3$	$8.3 \leq f_{IN}$
13	L	H	L	L	H	$f_{IN} < 7.7$	$7.7 \leq f_{IN}$
14	L	H	L	H	L	$f_{IN} < 7.14$	$7.14 \leq f_{IN}$
15	L	H	L	H	H	$f_{IN} < 6.67$	$6.67 \leq f_{IN}$
16	L	H	H	L	L	$f_{IN} < 6.25$	$6.25 \leq f_{IN}$
17	L	H	H	L	H	$f_{IN} < 5.88$	$5.88 \leq f_{IN}$
18	L	H	H	H	L	$f_{IN} < 5.56$	$5.56 \leq f_{IN}$
19	L	H	H	H	H	$f_{IN} < 5.26$	$5.26 \leq f_{IN}$
20	H	L	L	L	L	$f_{IN} = 5.00$	$5.00 \leq f_{IN}$
22	H	L	L	L	H	NA	$5.00 \leq f_{IN}$
24	H	L	L	H	L	NA	$5.00 \leq f_{IN}$
26	H	L	L	H	H	NA	$5.00 \leq f_{IN}$
28	H	L	H	L	L	NA	$5.00 \leq f_{IN}$
30	H	L	H	L	H	NA	$5.00 \leq f_{IN}$
32	H	L	H	H	L	NA	$5.00 \leq f_{IN}$
34	H	L	H	H	H	NA	$5.00 \leq f_{IN}$
36	H	H	L	L	L	NA	$5.00 \leq f_{IN}$
38	H	H	L	L	H	NA	$5.00 \leq f_{IN}$
40	H	H	L	H	L	NA	$5.00 \leq f_{IN}$
†	H	H	L	H	H	NA	NA
†	H	H	H	L	L	NA	NA
†	H	H	H	L	H	NA	NA
†	H	H	H	H	L	NA	NA
†	H	H	H	H	H	NA	NA

H = high level, L = low level † = Reserved

SN65LVDS150 MuxIt™ PLL FREQUENCY MULTIPLIER

SLLS443 – DECEMBER 2000

equivalent input and output schematic diagrams

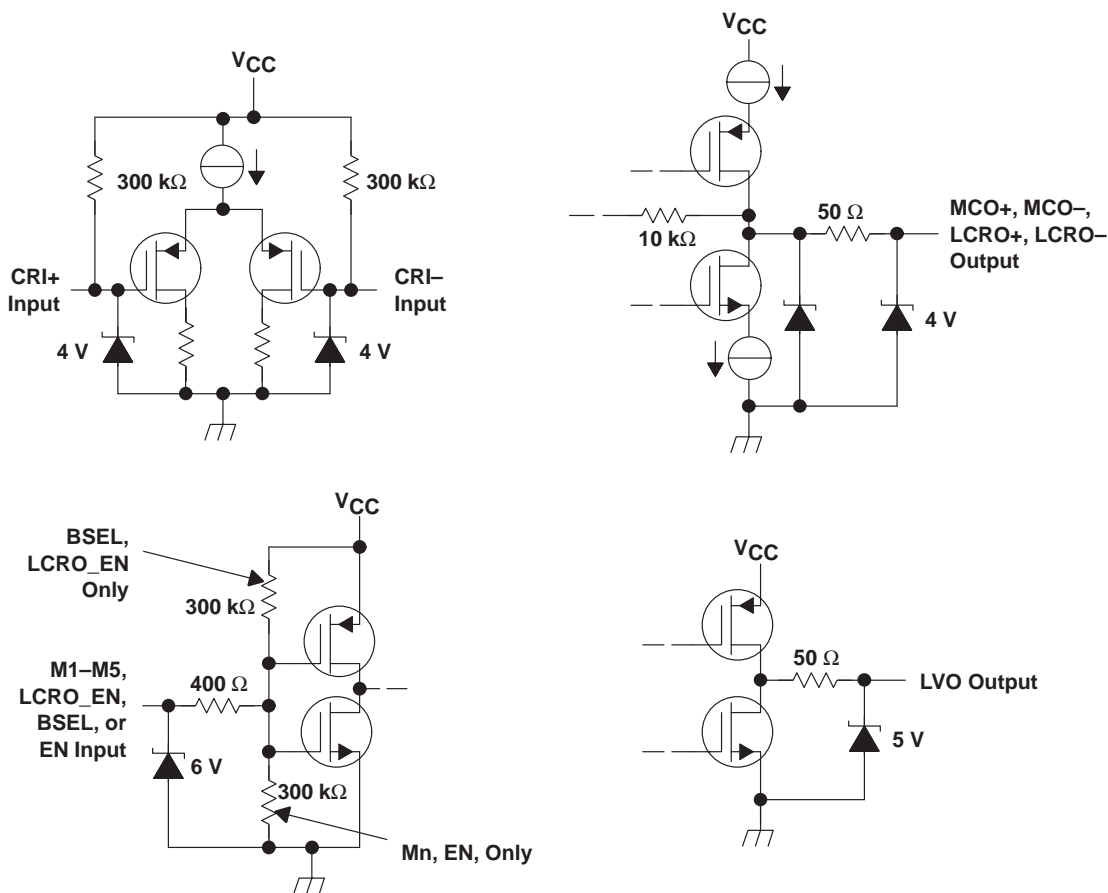

Terminal Functions

TERMINAL NAME	NO.	I/O	TYPE	DESCRIPTION
BSEL	11	I	LVTTTL	Band select. Used to optimize VCO performance for minimum M-clock jitter: See recommended f_{max} in the frequency multiplier value table.
CRI+, CRI-	2, 3	I	LVDS	Clock reference input. This is the reference clock signal for the PLL frequency multiplier.
EN	17	I	LVTTTL	Enable input. Used to disable the device to a low power state. A high level input enables the device, a low level input disables the device.
GND	5, 12, 18, 22, 24	I	NA	Circuit ground
LCRO-, LCRO+	13, 14	O	LVDS	Link clock reference output. This is the data block synchronization clock signal from the PLL frequency multiplier.
LCRO_EN	16	I	LVTTTL	LCRO enable. Used to turn off the LCRO outputs when they are not used. A high level input enables the LCRO output; a low level input disables the LCRO output.
LVO	15	O	LVTTTL	Lock/valid output. This is signal required for proper MuxIt system operation. It is to be directly connected to the LVI inputs of SN65LVDS151 or SN65LVDS152 devices. It is used to inhibit the operation of those devices until after the PLL has stabilized. It remains at a low level following a reset until the PLL has become phase locked. A low to high-level transition indicates phase lock has occurred.
M1–M5	6–10	I	LVTTTL	Multiplier value selection inputs. These inputs determine the frequency multiplication ratio M.
MCO-, MCO+	19,20	O	LVDS	M-clock output. This is the high frequency multiplied clock output from the PLL frequency multiplier. It is used by the companion serializer or deserializer devices to synchronizes the transmission or reception of data
NC	21, 23, 26–28		NA	These pins are not connected and may be left open.
V _{CC}	1, 25		NA	Supply voltage
V _T	4		NA	Voltage reference. A $V_{CC}/2$ reference supplied for the unused CRI input when operated in a single-ended mode.

absolute maximum ratings over operating free-air temperature range (unless otherwise noted)†

Supply voltage range, V _{CC} (see Note 1)	–0.5 V to 4 V
Voltage range: EN, BSEL, LCRO_EN, or M1–M5 inputs	–0.5 V to 6 V
CRI input	–0.5 V to 4 V
LCRO±, MCO± outputs	–0.5 V to 4 V
Electrostatic discharge: Human body model (CRI±, LCRO±, MCO±, and GND (see Note 2))	±12 kV
All pins	±2 kV
Charged-device model (all pins) (see Note 3)	±500 V
Continuous total power dissipation	See Dissipation Rating Table
Storage temperature range, T _{stg}	–65°C to 150°C
Lead temperature 1,6 mm (1/16 inch) from case for 10 seconds	260°C

† Stresses beyond those listed under “absolute maximum ratings” may cause permanent damage to the device. These are stress ratings only, and functional operation of the device at these or any other conditions beyond those indicated under “recommended operating conditions” is not implied. Exposure to absolute-maximum-rated conditions for extended periods may affect device reliability.

- NOTES: 1. All voltages, except differential I/O bus voltages, are with respect to the network ground terminal.
 2. Tested in accordance with JEDEC Standard 22, Test method A114-B.
 3. Tested in accordance with JEDEC Standard 22, Test method C101.

DISSIPATION RATING TABLE

PACKAGE	T _A ≤ 25°C POWER RATING	DERATING FACTOR‡ ABOVE T _A = 25°C	T _A = 85°C POWER RATING
PW	1207 mW	9.6 mW/°C	628 mW

‡ This is the inverse of the junction-to-ambient thermal resistance when board-mounted and with no air flow.

SN65LVDS150

MuxIt™ PLL FREQUENCY MULTIPLIER

SLLS443 – DECEMBER 2000

recommended operating conditions

		MIN	NOM	MAX	UNIT
Supply voltage, V_{CC}		3	3.3	3.6	V
High-level input voltage, V_{IH}	EN, BSEL, LCRO_EN, M1 – M5	2			V
Low-level input voltage, V_{IL}		0.8			V
Magnitude of differential input voltage, $ V_{ID} $	CRI	0.1	0.6		V
Common-mode input voltage, V_{IC}	CRI	$\frac{ V_{ID} }{2}$	$2.4 - \frac{ V_{ID} }{2}$		V
		$V_{CC} - 0.8$			
Operating free-air temperature, T_A		-40	85		°C

timing requirements

		MIN	TYP	MAX	UNIT
Input clock cycle time, $t_{c(1)}$		20		200	ns
High-level input clock pulse width duration, $t_{w(1)}$		$0.4 t_{c(1)}$		$0.6 t_{c(1)}$	
Input clock frequency, CRI, $f_{(clock)}$		5		50	MHz



electrical characteristics over recommended operating conditions (unless otherwise noted)

PARAMETER		TEST CONDITIONS	MIN	TYP†	MAX	UNIT
V _{IT+}	Positive-going differential input threshold voltage	See Figure 1 and Table 1			100	mV
V _{IT-}	Negative-going differential input threshold voltage		-100			mV
V _{OD(SS)}	Steady-state differential output voltage magnitude	R _L = 100 Ω, See Figure 3	247	340	454	mV
ΔV _{OD(SS)}	Change in steady-state differential output voltage magnitude between logic states	V _{ID} = ±100 mV, See Figures 2 and 3	-50		50	mV
V _{OC(SS)}	Steady-state common-mode output voltage	See Figure 4	1.125		1.375	V
ΔV _{OC(SS)}	Change in steady-state common-mode output voltage between logic states		-50		50	mV
V _{OC(PP)}	Peak-to-peak change common-mode output voltage			50	150	mV
V _{OH}	High-level output voltage (LVO)	I _{OH} = -8 mA	2.4			V
V _{OL}	Low-level output voltage (LVO)	I _{OL} = 8 mA			0.4	V
V _(T)	Threshold reference bias voltage	-100 μA ≤ I _O ≤ 100 μA	$\frac{V_{CC}}{2} - 0.15$		$\frac{V_{CC}}{2} + 0.15$	V
I _{CC}	Supply current	Enabled, R _L = 100 Ω, CRI± open		25	70	mA
		Disabled		2.5	6	
I _I	Input current (CRI inputs)	V _I = 0	-20		-2	μA
		V _I = 2.4 V	-1.2			
I _(ID)	Differential input current (I _{IA} - I _{IB}) (CRI inputs)	V _{IC} = 0.05 V or 2.35 V, V _{ID} = ±0.1 V	-2		2	μA
I _{I(OFF)}	Power-off input current (CRI inputs)	V _{CC} = 0 V, V _I = 3.6 V			20	μA
I _{IH}	High-level input current	M1-M5, EN			20	μA
		BSEL, LCRO_EN	V _{IH} = 2 V		-10	
I _{IL}	Low-level input current	M1-M5, EN			10	μA
		BSEL, LCRO_EN	V _{IL} = 0.8 V		-20	
I _{OS}	Short-circuit output current	MCO, LCRO	V _{O+} or V _{O-} = 0 V		10	mA
			V _{OD} = 0 V		-10	
I _{OZ}	High-impedance output current	MCO, LCRO	V _O = 0 V or V _{CC}		5	μA
I _{O(OFF)}	Power-off output current		V _{CC} = 1.5 V, V _O = 3.6 V		5	μA
C _I	Input capacitance (CRI inputs)		V _{ID} = [(0.4sin(4E6πt)) = 0.5] V		3	pF

† All typical values are at T_A = 25°C and with V_{CC} = 3.3 V.

SN65LVDS150

MuxIt™ PLL FREQUENCY MULTIPLIER

SLLS443 – DECEMBER 2000

switching characteristics over recommended operating conditions (unless otherwise noted)

PARAMETER		TEST CONDITIONS	MIN	TYP†	MAX	UNIT
MCO output clock period jitter‡	p-p	EN = 1, BSEL = 1, LCRO_EN = 1, M = 40, f _I = 5 MHz	200			ps
	rms		20			
t _(lock)	Lock (stabilization time)§		0.2	1	ms	
t _{w(2)}	Multiplied clock output pulse width	R _L = 100 Ω, C _L = 10 pF, See Figure 5	0.4t _{c(2)}			ns
t _r	Differential output signal rise time (MCO, LCRO)		0.3	0.6	1.5	
t _f	Differential output signal fall time (MCO, LCRO)		0.3	0.6	1.5	
t _(OS)	CRI↑ to MCO↑ offset time	f _I = 5 MHz, M = 4	-2.5	0	2.5	ns
		f _I = 10 MHz, M = 10	-1.5	0	1.5	
		f _I = 5 MHz, M = 40	-1.65	0	1.65	
t _d	MCO↑ before LCRO↑, time delay	f _I = 5 MHz, M = 4	0.5	2.5	6	ns
		f _I = 10 MHz, M = 10	0.5	2.5	6	
		f _I = 5 MHz, M = 40	0.5	2.5	4.5	
f _{max}	Maximum MCO output frequency	BSEL = 1, M = 4, 6	200			MHz
		BSEL = 1, M ≠ 4, 6	400			
		BSEL = 0, M = 4, 6	50			
		BSEL = 0, M ≠ 4, 6	100			

† All typical values are at T_A = 25°C and with V_{CC} = 3.3 V.

‡ Output clock jitter is the change in the output clock period from one cycle to the next cycle observed over 10,000 cycles with a source having less than 10 psec jitter rms.

§ Lock time is measured from the application of the clock reference input signal to the assertion of a high-level lock/valid output.

PARAMETER MEASUREMENT INFORMATION

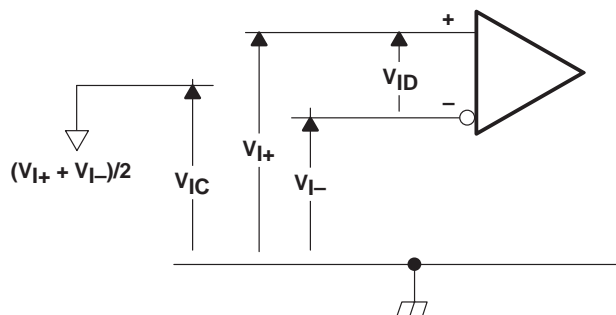

Figure 1. Receiver Input Voltage Definitions

PARAMETER MEASUREMENT INFORMATION

Table 1. Receiver Minimum and Maximum Input Threshold Test Voltages

APPLIED VOLTAGES		RESULTING DIFFERENTIAL INPUT VOLTAGE	RESULTING COMMON-MODE INPUT VOLTAGE
$V_{(IA)}$	$V_{(IB)}$	V_{ID}	V_{IC}
1.25 V	1.15 V	100 mV	1.2 V
1.15 V	1.25 V	-100 mV	1.2 V
2.4 V	2.3 V	100 mV	2.35 V
2.3 V	2.4 V	-100 mV	2.35 V
0.1 V	0 V	100 mV	0.05 V
0 V	0.1 V	-100 mV	0.05 V
1.5 V	0.9 V	600 mV	1.2 V
0.9 V	1.5 V	-600 mV	1.2 V
2.4 V	1.8 V	600 mV	2.1 V
1.8 V	2.4 V	-600 mV	2.1 V
0.6 V	0 V	600 mV	0.3 V
0 V	0.6 V	-600 mV	0.3 V

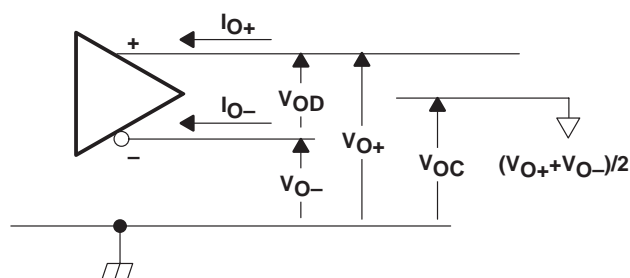

Figure 2. Driver Output Voltage and Current Definitions

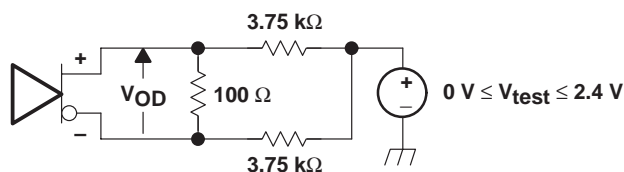
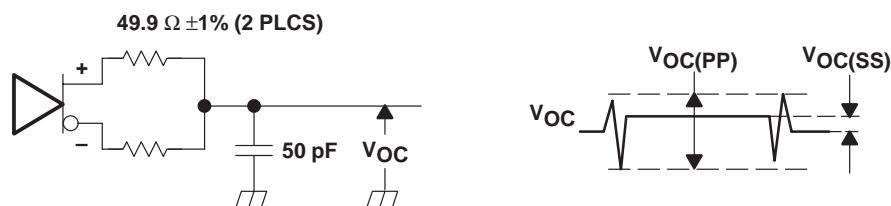

Figure 3. V_{OD} Test Circuit



NOTE A: All input pulses are supplied by a generator having the following characteristics: t_r or $t_f \leq 1$ ns, pulse repetition rate (PRR) = 0.5 Mpps, Pulse width = 500 ± 10 ns. C_L includes instrumentation and fixture capacitance within 0,06 m of the D.U.T. The measurement of $V_{OC(PP)}$ is made on test equipment with a -3 dB bandwidth of at least 5 GHz.

Figure 4. Test Circuit and Definitions for the Driver Common-Mode Output Voltage

PARAMETER MEASUREMENT INFORMATION

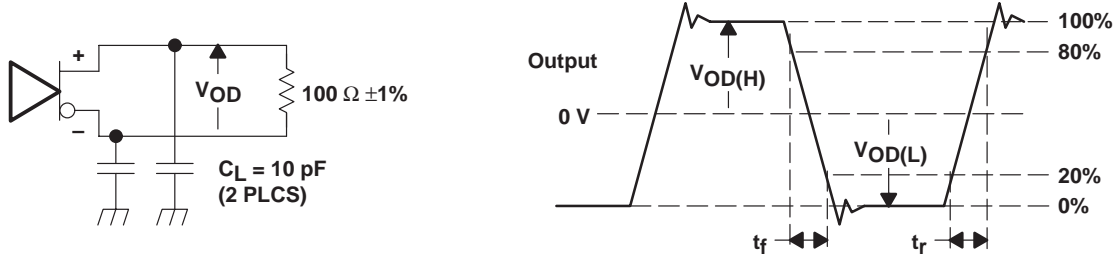

NOTE A: All input pulses are supplied by a generator having the following characteristics: t_r or $t_f \leq 1$ ns, pulse repetition rate (PRR) = 50 Mpps, Pulse width = 10 ± 0.2 ns. C_L includes instrumentation and fixture capacitance within 0,06 m of the D.U.T.

Figure 5. Test Circuit, Timing, and Voltage Definitions for the Differential Output Signal

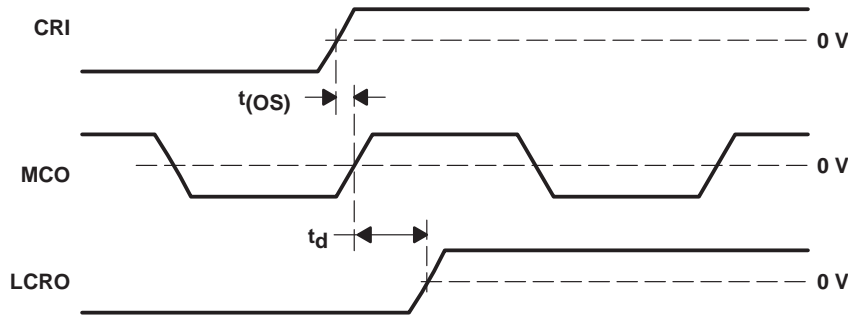

Figure 6. Output Timing Waveform Definitions

TYPICAL CHARACTERISTICS

SUPPLY CURRENT
vs
MCO FREQUENCY

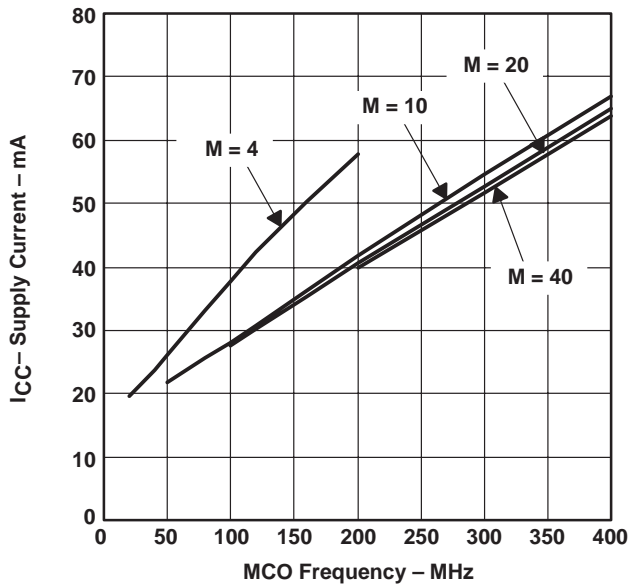

Figure 7

JITTER
vs
MCO FREQUENCY

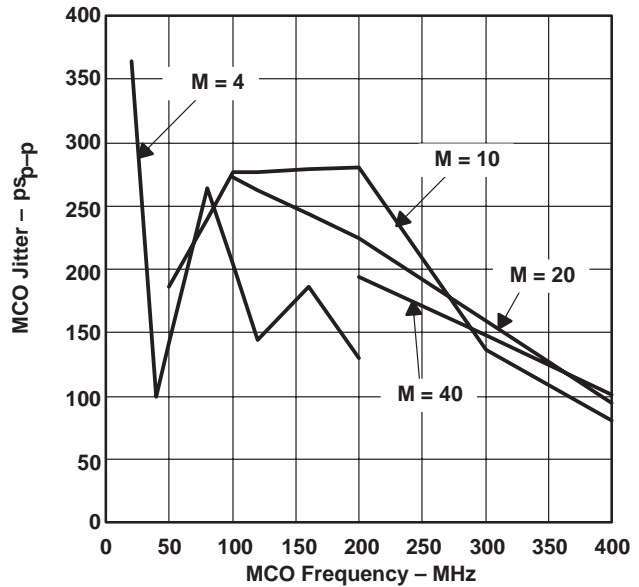

Figure 8

NOTE: M = Multiplying Value (see Page 3)

TYPICAL CHARACTERISTICS

basic applications examples

Parallel data path width between 4 and 10 bits, only one LVDS data link required.

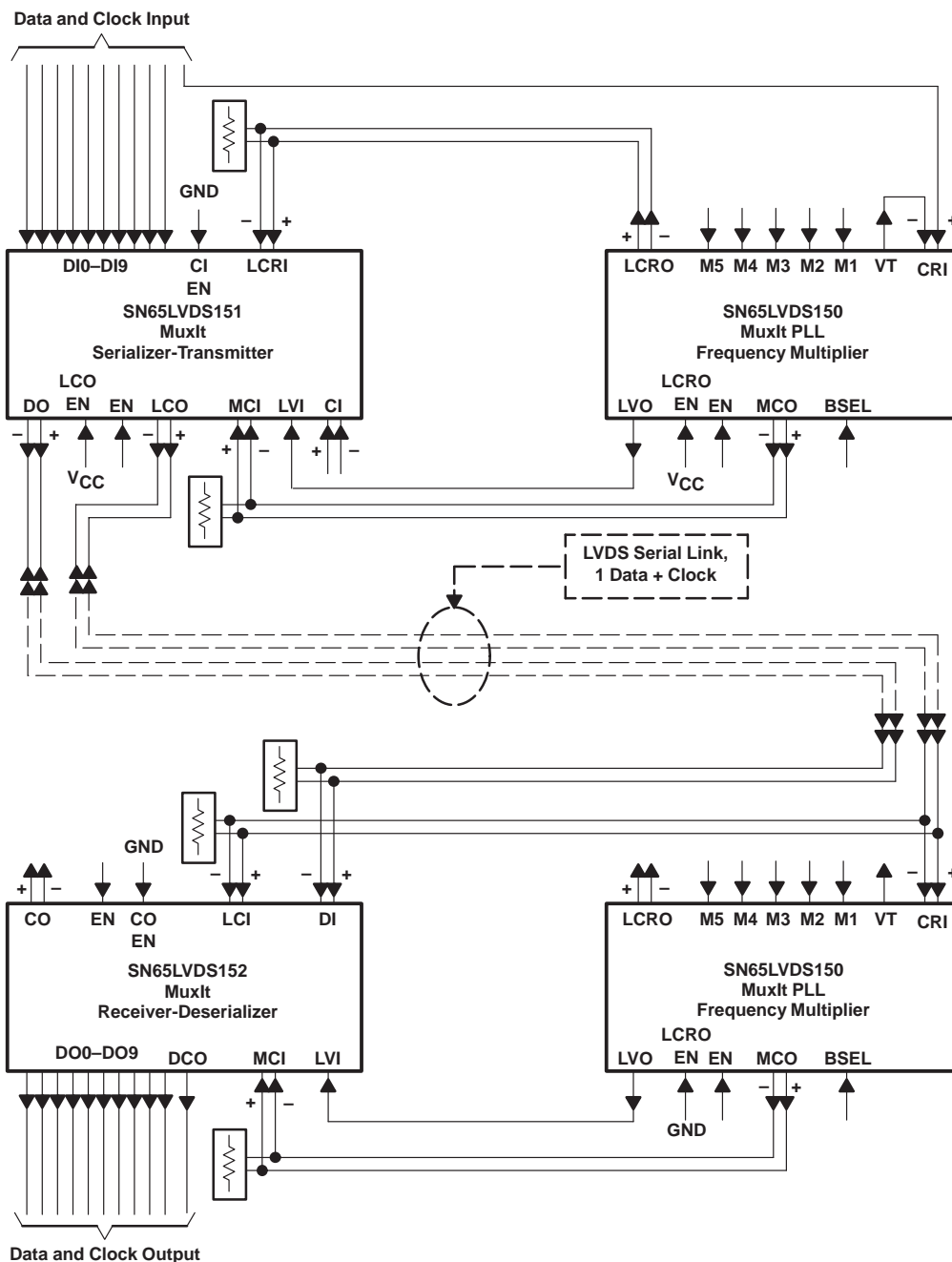

(a)

SN65LVDS150 MuxIt™ PLL FREQUENCY MULTIPLIER

SLLS443 – DECEMBER 2000

TYPICAL CHARACTERISTICS

Parallel data path width between 11 and 20 bits, aggregate data rate low enough to allow transmission over one LVDS data link, sharing of PLL-FM between serializer-transmitter and receiver-deserializer chips at each end.

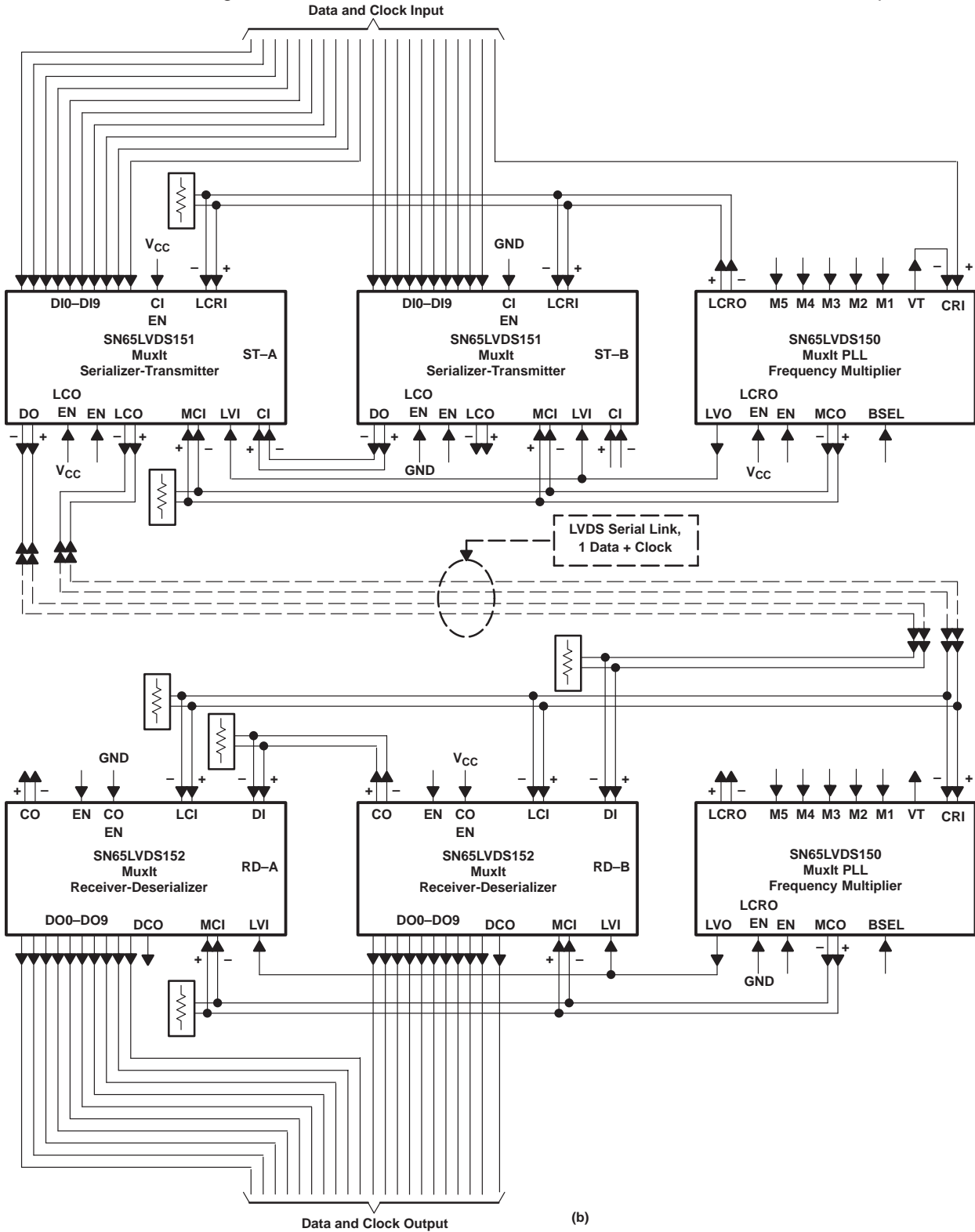

TYPICAL CHARACTERISTICS

Parallel data path width between 11 and 20 bits, aggregate data rate requires transmission over two separate LVDS data links, sharing of PLL-FM between serializer-transceiver and receiver-deserializer chips at each end.

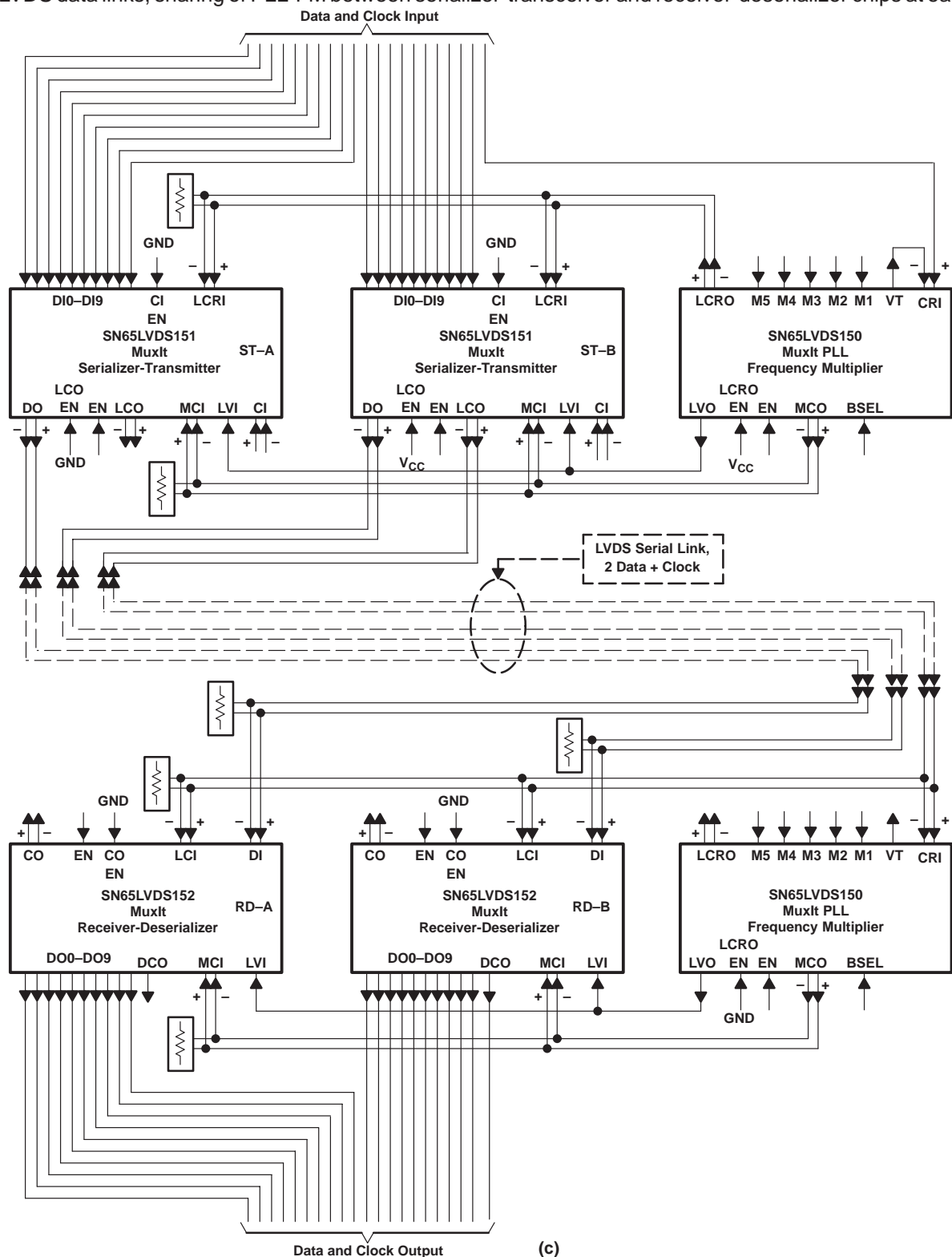

SN65LVDS150 MuxIt™ PLL FREQUENCY MULTIPLIER

SLLS443 – DECEMBER 2000

MECHANICAL INFORMATION

PW (R-PDSO-G**)

PLASTIC SMALL-OUTLINE PACKAGE

14 PINS SHOWN

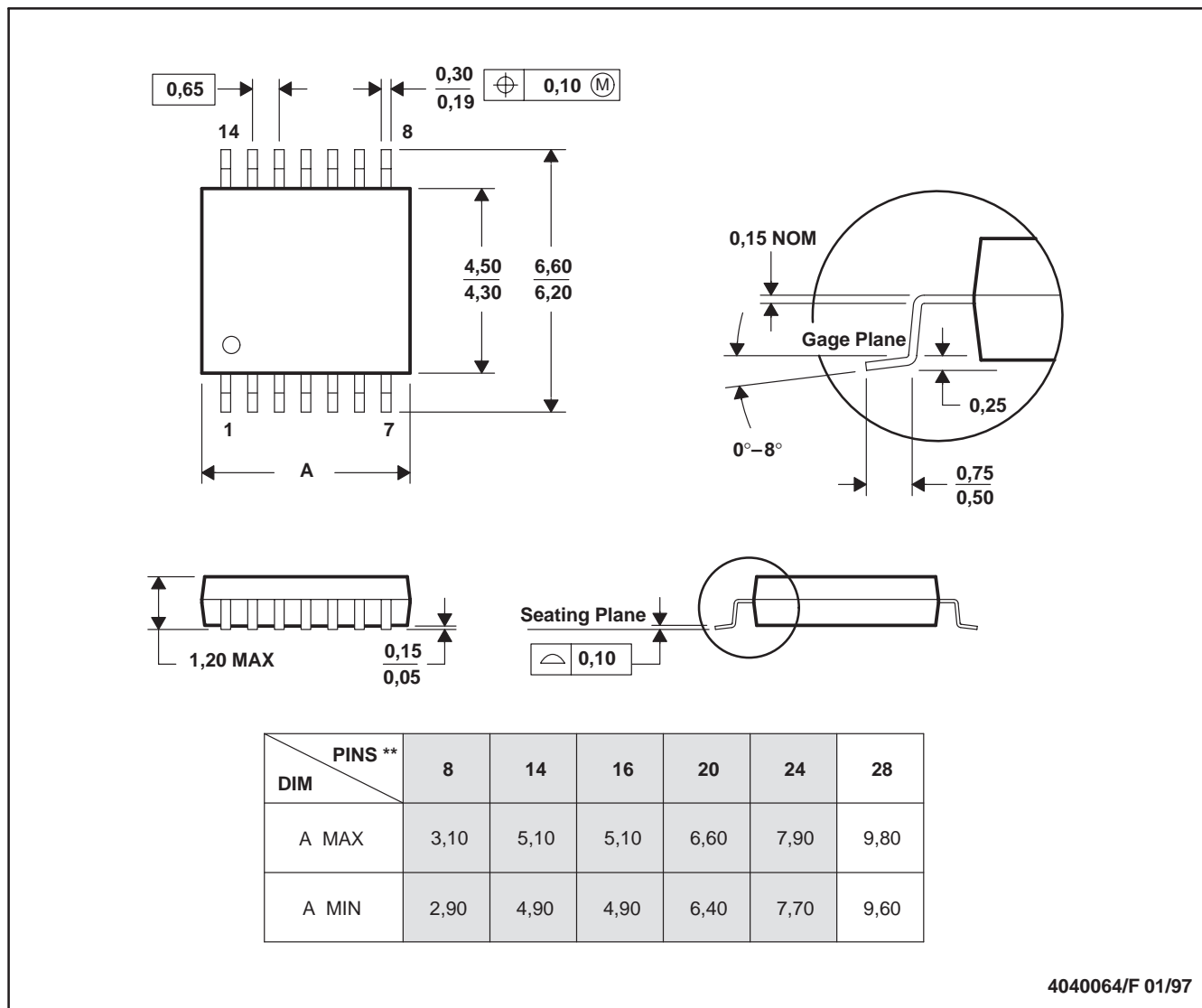

4040064/F 01/97

- NOTES: A. All linear dimensions are in millimeters.
 B. This drawing is subject to change without notice.
 C. Body dimensions do not include mold flash or protrusion not to exceed 0,15.
 D. Falls within JEDEC MO-153

PACKAGING INFORMATION

Orderable Device	Status ⁽¹⁾	Package Type	Package Drawing	Pins	Package Qty	Eco Plan ⁽²⁾	Lead/Ball Finish	MSL Peak Temp ⁽³⁾
SN65LVDS150PW	ACTIVE	TSSOP	PW	28	50	None	CU NIPDAU	Level-2-220C-1 YEAR
SN65LVDS150PWR	ACTIVE	TSSOP	PW	28	2000	None	CU NIPDAU	Level-2-220C-1 YEAR

⁽¹⁾ The marketing status values are defined as follows:

ACTIVE: Product device recommended for new designs.

LIFEBUY: TI has announced that the device will be discontinued, and a lifetime-buy period is in effect.

NRND: Not recommended for new designs. Device is in production to support existing customers, but TI does not recommend using this part in a new design.

PREVIEW: Device has been announced but is not in production. Samples may or may not be available.

OBsolete: TI has discontinued the production of the device.

⁽²⁾ Eco Plan - May not be currently available - please check <http://www.ti.com/productcontent> for the latest availability information and additional product content details.

None: Not yet available Lead (Pb-Free).

Pb-Free (RoHS): TI's terms "Lead-Free" or "Pb-Free" mean semiconductor products that are compatible with the current RoHS requirements for all 6 substances, including the requirement that lead not exceed 0.1% by weight in homogeneous materials. Where designed to be soldered at high temperatures, TI Pb-Free products are suitable for use in specified lead-free processes.

Green (RoHS & no Sb/Br): TI defines "Green" to mean "Pb-Free" and in addition, uses package materials that do not contain halogens, including bromine (Br) or antimony (Sb) above 0.1% of total product weight.

⁽³⁾ MSL, Peak Temp. -- The Moisture Sensitivity Level rating according to the JEDEC industry standard classifications, and peak solder temperature.

Important Information and Disclaimer: The information provided on this page represents TI's knowledge and belief as of the date that it is provided. TI bases its knowledge and belief on information provided by third parties, and makes no representation or warranty as to the accuracy of such information. Efforts are underway to better integrate information from third parties. TI has taken and continues to take reasonable steps to provide representative and accurate information but may not have conducted destructive testing or chemical analysis on incoming materials and chemicals. TI and TI suppliers consider certain information to be proprietary, and thus CAS numbers and other limited information may not be available for release.

In no event shall TI's liability arising out of such information exceed the total purchase price of the TI part(s) at issue in this document sold by TI to Customer on an annual basis.

IMPORTANT NOTICE

Texas Instruments Incorporated and its subsidiaries (TI) reserve the right to make corrections, modifications, enhancements, improvements, and other changes to its products and services at any time and to discontinue any product or service without notice. Customers should obtain the latest relevant information before placing orders and should verify that such information is current and complete. All products are sold subject to TI's terms and conditions of sale supplied at the time of order acknowledgment.

TI warrants performance of its hardware products to the specifications applicable at the time of sale in accordance with TI's standard warranty. Testing and other quality control techniques are used to the extent TI deems necessary to support this warranty. Except where mandated by government requirements, testing of all parameters of each product is not necessarily performed.

TI assumes no liability for applications assistance or customer product design. Customers are responsible for their products and applications using TI components. To minimize the risks associated with customer products and applications, customers should provide adequate design and operating safeguards.

TI does not warrant or represent that any license, either express or implied, is granted under any TI patent right, copyright, mask work right, or other TI intellectual property right relating to any combination, machine, or process in which TI products or services are used. Information published by TI regarding third-party products or services does not constitute a license from TI to use such products or services or a warranty or endorsement thereof. Use of such information may require a license from a third party under the patents or other intellectual property of the third party, or a license from TI under the patents or other intellectual property of TI.

Reproduction of information in TI data books or data sheets is permissible only if reproduction is without alteration and is accompanied by all associated warranties, conditions, limitations, and notices. Reproduction of this information with alteration is an unfair and deceptive business practice. TI is not responsible or liable for such altered documentation.

Resale of TI products or services with statements different from or beyond the parameters stated by TI for that product or service voids all express and any implied warranties for the associated TI product or service and is an unfair and deceptive business practice. TI is not responsible or liable for any such statements.

Following are URLs where you can obtain information on other Texas Instruments products and application solutions:

Products		Applications	
Amplifiers	amplifier.ti.com	Audio	www.ti.com/audio
Data Converters	dataconverter.ti.com	Automotive	www.ti.com/automotive
DSP	dsp.ti.com	Broadband	www.ti.com/broadband
Interface	interface.ti.com	Digital Control	www.ti.com/digitalcontrol
Logic	logic.ti.com	Military	www.ti.com/military
Power Mgmt	power.ti.com	Optical Networking	www.ti.com/opticalnetwork
Microcontrollers	microcontroller.ti.com	Security	www.ti.com/security
		Telephony	www.ti.com/telephony
		Video & Imaging	www.ti.com/video
		Wireless	www.ti.com/wireless

Mailing Address: Texas Instruments
Post Office Box 655303 Dallas, Texas 75265