

- A Member of the MuxIt™ Serializer-Deserializer Building-Block Chip Family
- Supports Deserialization of One Serial Link Data Channel Input at Rates up to 200 Mbps
- PLL Lock/Valid Input Provided to Enable Parallel Data and Clock Outputs
- Cascadable With Additional SN65LVDS152 MuxIt Receiver–Deserializers for Wider Parallel Output Data Channel Widths
- LVDS Compatible Differential Inputs and Outputs Meet or Exceed the Requirements of ANSI TIA/EIA-644-A
- LVDS Input and Output ESD Protection Exceeds 12 kV HBM
- LVTTTL Compatible Inputs for Lock/Valid and Enables Are 5-V Tolerant
- Operates With 3.3-V Supply
- Packaged in 32-Pin DA Thin Shrink Small-Outline Package With 26-Mil Terminal Pitch

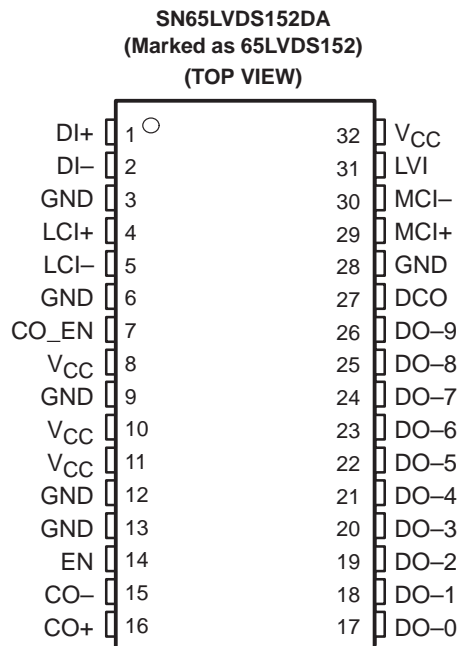

description

MuxIt is a family of general-purpose, multiple-chip building blocks for implementing parallel data serializers and deserializers. The system allows for wide parallel data to be transmitted through a reduced number of transmission lines over distances greater than can be achieved with a single-ended (e.g., LVTTTL or LVCMOS) data interface. The number of bits multiplexed per transmission line is user selectable, allowing for higher transmission efficiencies than with other existing fixed ratio solutions. MuxIt utilizes the LVDS (TIA/EIA-644-A) low voltage differential signaling technology for communications between the data source and data destination.

The MuxIt family initially includes three devices supporting simplex communications: the SN65LVDS150 phase locked loop frequency multiplier, the SN65LVDS151 serializer-transmitter, and the SN65LVDS152 receiver-deserializer.

The SN65LVDS152 consists of three LVDS differential transmission line receivers, an LVDS differential transmission line driver, a 10-bit serial-in/parallel-out shift register, plus associated input and output buffers. It receives serialized data over an LVDS transmission line link, deserializes (demultiplexes) it, and delivers it on parallel data outputs, DO-0 through DO-9. Data received over the link is clocked at a factor of M times the original parallel data frequency. The multiplexing ratio M, or number of bits per data clock cycle, is programmed with configuration pins (M1 → M5) on the companion SN65LVDS150 MuxIt programmable PLL frequency multiplier. Up to 10 bits of data may be deserialized and output by each SN65LVDS152. Two or more SN65LVDS152 units may be connected in series (cascaded) to accommodate wider parallel data paths for higher serialization values. The range of multiplexing ratio M supported by the SN65LVDS150 MuxIt programmable PLL frequency multiplier is between 4 and 40. Table 1 shows some of the combinations of LCI and MCI supported by the SN65LVDS150 MuxIt programmable PLL frequency multiplier.



Please be aware that an important notice concerning availability, standard warranty, and use in critical applications of Texas Instruments semiconductor products and disclaimers thereto appears at the end of this data sheet.

MuxIt is a trademark of Texas Instruments.

PRODUCTION DATA information is current as of publication date. Products conform to specifications per the terms of Texas Instruments standard warranty. Production processing does not necessarily include testing of all parameters.



POST OFFICE BOX 655303 • DALLAS, TEXAS 75265

Copyright © 2000, Texas Instruments Incorporated

SN65LVDS152 MuxIt™ RECEIVER-DESERIALIZER

SLLS445 – DECEMBER 2000

description (continued)

Data is serially shifted into the SN65LVDS152 shift register on the falling edges of the M-clock input (MCI). The data is latched out in parallel from the SN65LVDS152 shift register on the second rising edge after the first falling edge of the M-clock following a rising edge of the link clock input (LCI). The SN65LVDS152 includes LVDS differential line receivers for both the serialized link data stream (DI) and link clock (LCI). High-speed signals from the SN65LVDS150 MuxIt programmable frequency multiplier (MCI), plus the input and output for cascaded data (DI, CO) are carried over differential connections to minimize skew and jitter. Examples of operating waveforms for values of $M = 4$ and $M = 10$ are provided in Figure 1.

The enable input (EN) along with internal power-on reset (POR) controls the outputs. When V_{CC} is below 1.5 volts, or when EN is low, outputs are disabled. When V_{CC} is above 3 V and EN is high, outputs are enabled and operating to specifications.

Parallel data bits are output from DO-n outputs in an order dependent on the value of the multiplexing ratio (frequency multiplier value) M. For values of M from 4 through 10, the cascade output (CO+/-) is not used, and only the top M parallel outputs (DO-9 through DO-[10-M]) are used. The data bit output on DO-9 corresponds to the data bit input on DI-[M-1] of the SN65LVDS151 serializer. Likewise, the data bit output on DO-[10-M] will correspond to the data bit input on DI-0 of the SN65LVDS151 serializer.

For values of M greater than 10, the cascade output (CO+/-) is used to connect multiple SN65LVDS152 deserializers. In this case the higher-order unit(s) output 10 bits each of the highest numbered bits that are input into the SN65LVDS151 serializer(s). The lowest numbered input bits are output on the lowest-order SN65LVDS152 deserializer in descending order from output DO-9. The number of bits is equal to $M \bmod(10)$. Table 2 reflects this information, where $X = M \bmod(10)$

Table 1. Example Combinations of LCI and MCI Supported by the SN65LVDS150 MuxIt Programmable PLL Frequency Multiplier

M	LCI, MHz		MCI, MHz	
	MINIMUM	MAXIMUM	MINIMUM	MAXIMUM
4	5	50	20	200
10	5	20	50	200
20	5	10	100	200
40	5	5	200	200

Table 2. Output Data Bits as a Function of Multiplier Value M

	X = 1	X = 2	X = 3	X = 4	X = 5	X = 6	X = 7	X = 8	X = 9	X = 0
DO-9 output bit	DI-0	DI-1	DI-2	DI-3	DI-4	DI-5	DI-6	DI-7	DI-8	DI-9
DO-8 output bit	Invalid	DI-0	DI-1	DI-2	DI-3	DI-4	DI-5	DI-6	DI-7	DI-8
DO-7 output bit	Invalid	Invalid	DI-0	DI-1	DI-2	DI-3	DI-4	DI-5	DI-6	DI-7
DO-6 output bit	Invalid	Invalid	Invalid	DI-0	DI-1	DI-2	DI-3	DI-4	DI-5	DI-6
DO-5 output bit	Invalid	Invalid	Invalid	Invalid	DI-0	DI-1	DI-2	DI-3	DI-4	DI-5
DO-4 output bit	Invalid	Invalid	Invalid	Invalid	Invalid	DI-0	DI-1	DI-2	DI-3	DI-4
DO-3 output bit	Invalid	Invalid	Invalid	Invalid	Invalid	Invalid	DI-0	DI-1	DI-2	DI-3
DO-2 output bit	Invalid	Invalid	Invalid	Invalid	Invalid	Invalid	Invalid	DI-0	DI-1	DI-2
DO-1 output bit	Invalid	Invalid	Invalid	Invalid	Invalid	Invalid	Invalid	Invalid	DI-0	DI-1
DO-0 output bit	Invalid	Invalid	Invalid	Invalid	Invalid	Invalid	Invalid	Invalid	Invalid	DI-0

Additional information on output bit ordering in cascaded applications can be found in the MuxIt Application Report.



description (continued)

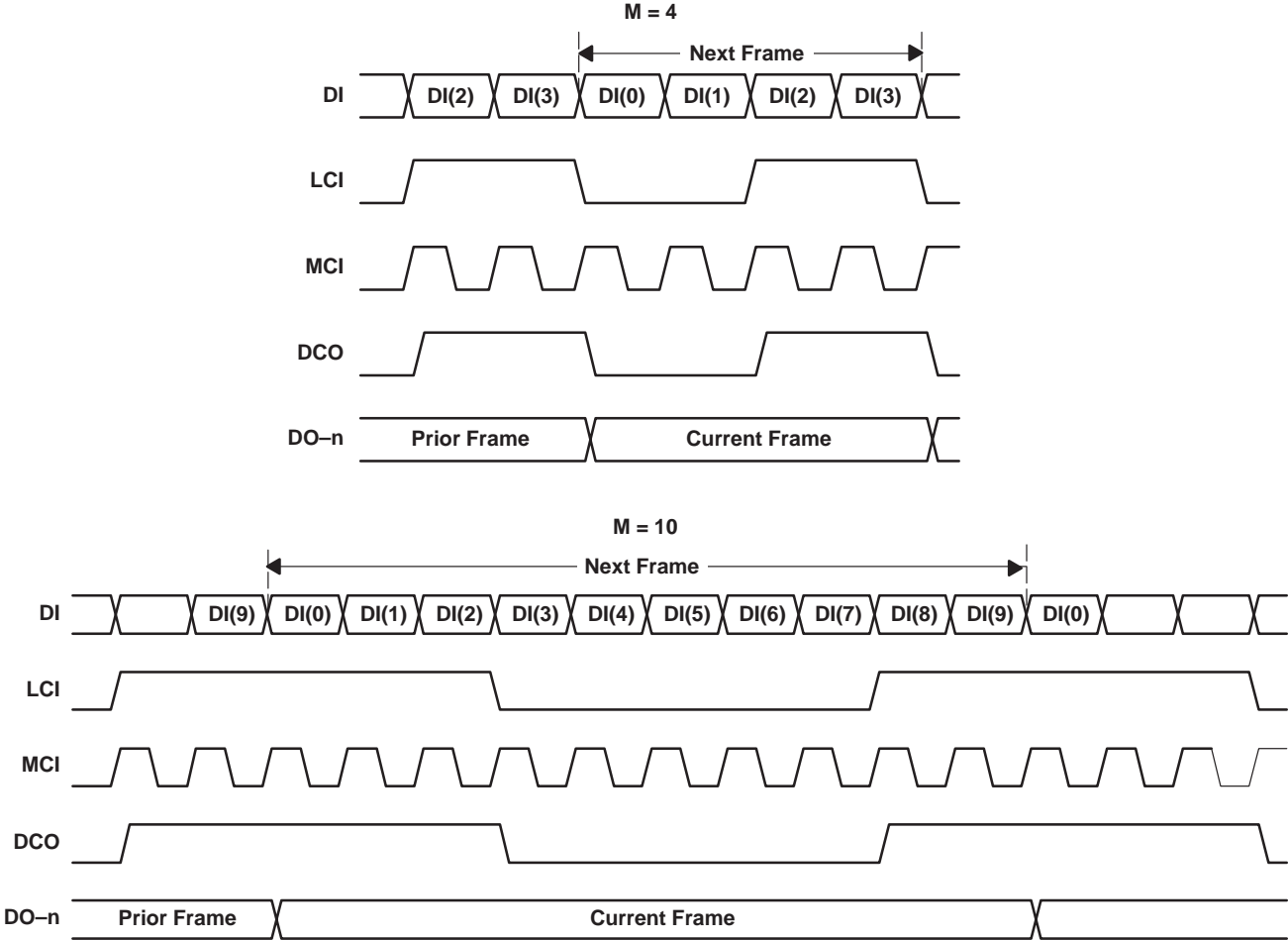
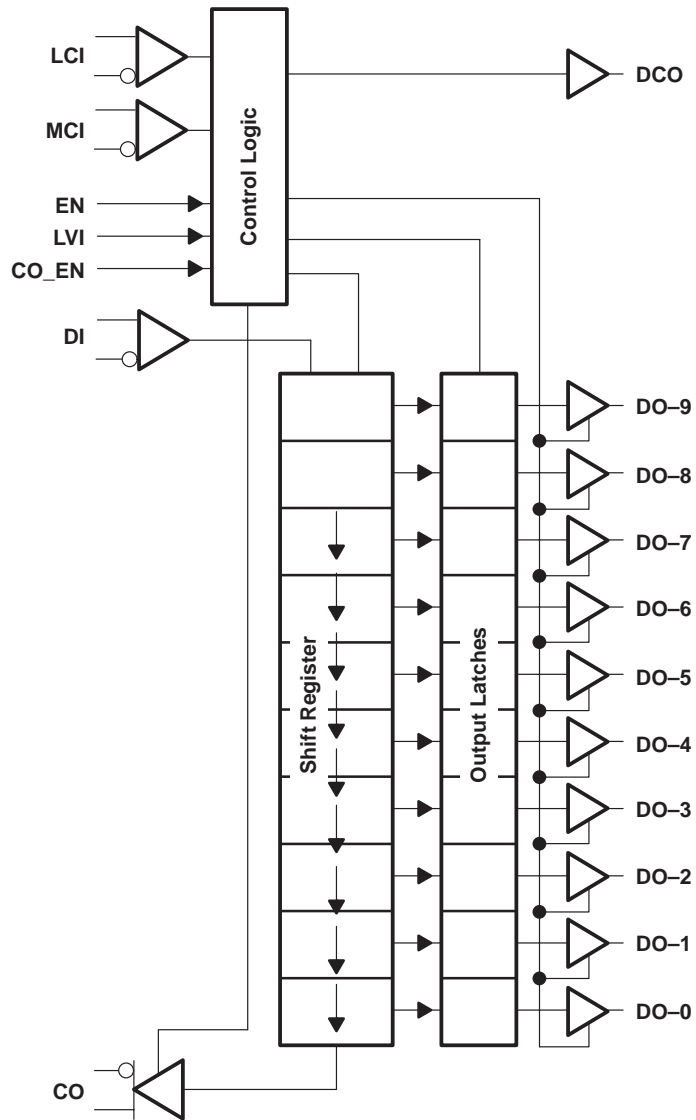

Figure 1. Operating Waveform Examples

SN65LVDS152 MuxIt™ RECEIVER-DESERIALIZER

SLLS445 – DECEMBER 2000

functional block diagram



equivalent input and output schematic diagrams

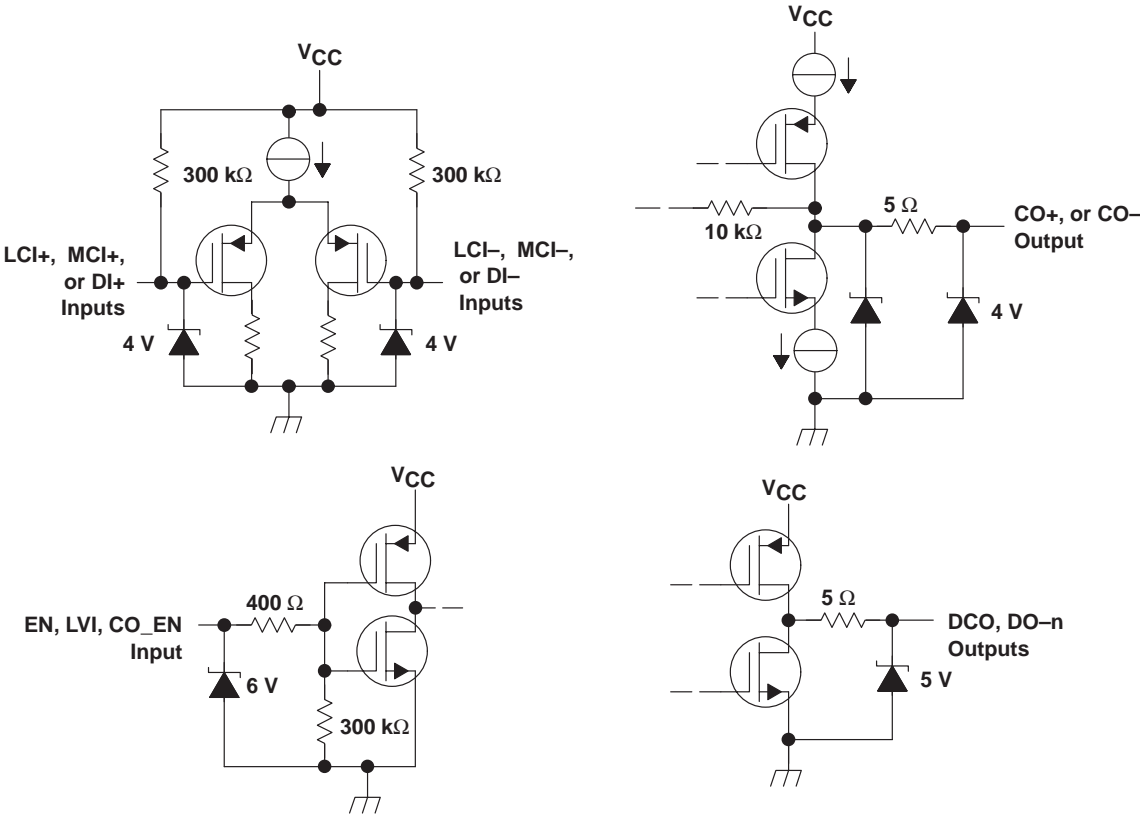

SN65LVDS152 MuxIt™ RECEIVER-DESERIALIZER

SLLS445 – DECEMBER 2000

Terminal Functions

TERMINAL NAME		NO.	I/O	LEVEL	DESCRIPTION
CO-, CO+	15, 16	Output	LVDS	Cascade output. This is used to connect to additional SN65LVDS152 units when the multiplexing ratio M (and M-clock) value is greater than 10.	
CO_EN	7	Input	LVTTTL	Cascade output enable. Used to control the CO output. A high-level input enables the CO output, a low-level input disables the CO output.	
DCO	27	Output	LVTTTL	Data clock output. This is the recovered (original frequency) clock that is synchronized to the deserialized parallel data.	
DI+, DI-	1, 2	Input	LVDS	Link data input. This is the data being received from the source end of the serialized link. Also used for cascade data input from additional SN65LVDS152 units when the multiplexing ratio M value is greater than 10.	
EN	14	Input	LVTTTL	Enable. Used to control overall device operation. A high-level input enables the device. A low-level input disables the device by resetting the internal latches and forcing the CO and LVTTTL outputs to a high-impedance state.	
GND	3, 6, 9, 12, 13, 28	Power	NA	Circuit ground	
LCI+, LCI-	4, 5	Input	LVDS	Link clock input. This is the data block synchronization clock received from the source end of the serialized link.	
LVI	31	Input	LVTTTL	Lock/valid input. This is a signal required for proper MuxIt system operation. It is to be directly connected to the LVO output of an SN65LVDS150. It is used to inhibit the operation of this device until after the PLL has stabilized. A low level input disables the data and clock outputs, a high level input enables the outputs	
MCI+, MCI-	29,30	Input	LVDS	M-clock input. This is the high frequency multiplied clock input from the local PLL frequency multiplier. It synchronizes the reception of the link data	
DO-0-DO-9	17-26	Output	LVTTTL	Parallel data outputs. Data from the serial shift register is transferred to the output data latches in synchronization with the rising edge of LCI.	
VCC	8, 10, 11, 32	Power	NA	Supply voltage	

absolute maximum ratings over operating free-air temperature (unless otherwise noted)†

Supply voltage range, V _{CC} (see Note 1)	-0.5 V to 4 V
Input voltage range: EN, LVI, CO_EN	-0.5 V to 5.5 V
LCI±, MCI±, DI±, CO±	-0.5 V to 4 V
Electrostatic discharge, human body model (see Note 2): LCI±, MCI±, DI±, CO±, and GND	±12 kV
All pins	±2 kV
Charged-device model (see Note 3): All pins	±500 V
Continuous power dissipation	See Dissipation Rating Table
Storage temperature range	-65°C to 150°C
Lead temperature 1,6 mm (1/16 inch) from case for 10 seconds	260°C

† Stresses beyond those listed under “absolute maximum ratings” may cause permanent damage to the device. These are stress ratings only, and functional operation of the device at these or any other conditions beyond those indicated under “recommended operating conditions” is not implied. Exposure to absolute-maximum-rated conditions for extended periods may affect device reliability.

- NOTES: 1. All voltage values, except differential I/O bus voltages, are with respect to network ground terminal.
2. Tested in accordance with JEDEC Standard 22, Test Method A114-B.
3. Tested in accordance with JEDEC Standard 22, Test Method C101.

DISSIPATION RATING TABLE

PACKAGE	T _A ≤ 25°C POWER RATING	DERATING FACTOR ABOVE T _A = 25°C	T _A = 85°C POWER RATING
DA	1453 mW	11.6 mW/°C	756 mW



recommended operating conditions

		MIN	NOM	MAX	UNIT
Supply voltage, V_{CC}		3	3.3	3.6	V
High-level input voltage, V_{IH}	EN, LVI, CO_EN	2	V_{CC}		V
Low-level input voltage, V_{IL}				0.8	V
Magnitude of differential input voltage, $ V_{ID} $	LCI±, MCI±, DI±	0.1		0.6	V
Common-mode input voltage, V_{IC}		$\frac{ V_{ID} }{2}$		$2.4 \frac{ V_{ID} }{2}$	V
				$V_{CC} - 0.8$	V
Operating free-air temperature, T_A		-40		85	°C

timing requirements

PARAMETERS		TEST CONDITIONS	MIN	MAX	UNIT
$t_{su(1)}$	Clock setup time, MCI↓ before LCI↑	See Figure 2	0		ns
$t_{su(2)}$	Clock setup time, LCI↑ before MCI↓		1		ns
$t_{su(3)}$	Link data setup time, DI before MCI↓	See Figure 3	0.3		ns
$t_h(3)$	Link data hold time, DI after MCI↓		0.5		ns

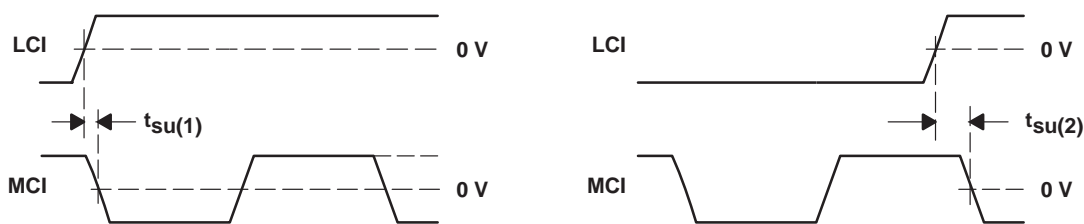

Figure 2

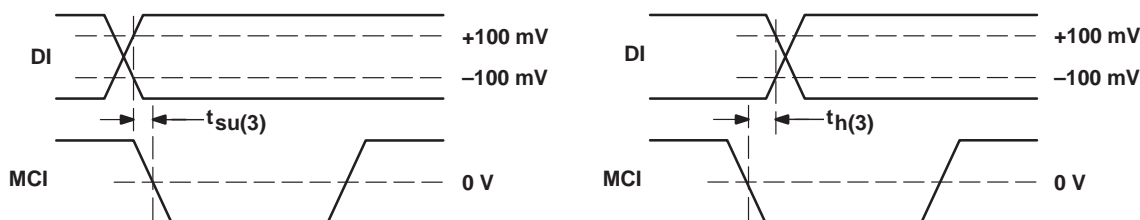

Figure 3. Input Data and M-Clock Setup and Hold Time Waveforms

SN65LVDS152

MuxIt™ RECEIVER-DESERIALIZER

SLLS445 – DECEMBER 2000

electrical characteristics over recommended operating conditions (unless otherwise noted)

PARAMETER		TEST CONDITIONS	MIN	TYP†	MAX	UNIT	
V_{ITH+}	Positive-going differential input voltage threshold	See Figure 4			100	mV	
V_{ITH-}	Negative-going differential input voltage threshold				-100		
$ V_{OD(SS)} $	Steady-state differential output voltage magnitude	$R_L = 100 \Omega$, $V_{ID} = \pm 100$ mV, See Figures 5 and 6	247	340	454	mV	
$\Delta V_{OD(SS)} $	Change in steady-state differential output voltage magnitude between logic states			-50	50	mV	
$V_{OC(SS)}$	Steady-state common-mode output voltage	See Figure 7	1.125		1.375	V	
$\Delta V_{OC(SS)}$	Change in steady-state common-mode output voltage between logic states			-50	50	mV	
$V_{OC(PP)}$	Peak-to-peak change common-mode output voltage				50	150	mV
V_{OH}	High-level output voltage	DO-n, DCO	$I_{OH} = -8$ mA		2.4	V	
V_{OL}	Low-level output voltage		$I_{OL} = 8$ mA		0.4		
I_{CC}	Supply current	LCl, MCl, DI inputs	Enabled, $R_L = 100 \Omega$,		14	25	mA
			Disabled		0.5	1	
			$f(MCl) = 200$ MHz, $f(LCl) = 20$ MHz, $R_L = 100 \Omega$, $DI-n = 1010101010$ at 200 Mbit/s		35	60	
I_I	Input current	LCl, MCl, DI inputs	$V_I = 0$ V		-2	-20	μ A
			$V_I = 2.4$ V		-1.2		
I_{ID}	Differential input current	LCl, MCl, DI inputs	$V_{IC} = 0.05$ V to 2.35 V, $V_{ID} = \pm 0.1$ V		-2	2	μ A
$I_{I(OFF)}$	Power-off input current	LCl, MCl, DI inputs	$V_{CC} = 0$ V, $V_I = 3.6$ V			20	μ A
I_{IH}	High-level input current	EN, LVI, CO_EN	$V_{IH} = 2$ V			20	μ A
I_{IL}	Low-level input current	EN, LVI, CO_EN	$V_{IL} = 0.8$ V			10	μ A
I_{OS}	Short-circuit output current	CO	V_{O+} or $V_{O-} = 0$ V		-10	10	mA
			$V_{OD} = 0$ V		-10	10	mA
I_{OZ}	High-impedance output current	CO	$V_O = 0$ V or V_{CC}		-5	5	μ A
		DO-n, DCO			-5	5	
$I_{O(OFF)}$	Power-off output current	CO	$V_{CC} = 1.5$ V, $V_O = 3.6$ V		-5	5	μ A
C_I	Input capacitance	LCl, MCl, DI inputs	$V_{ID} = (0.4\sin(4E6\pi t) + 0.5)$ V			3	pF

† All typical values are at $T_A = 25^\circ\text{C}$ and with $V_{CC} = 3.3$ V.



switching characteristics over recommended operating conditions (unless otherwise noted)

PARAMETER		TEST CONDITIONS	MIN	TYP	MAX	UNIT
$t_{d(1)}$	Propagation delay time, LCI \uparrow to DCO \uparrow	See Figure 8		2	3	ns
$t_{d(2)}$	Delay time, MCI \uparrow to DO-n			3.3	5.5	
$t_{su(4)}$	Set-up time, DO-n valid to DCO \uparrow			5		
$t_h(4)$	Hold time, DCO \uparrow to DO-n valid			5		
$t_{d(3)}$	Delay time, MCI \downarrow to CO	See Figure 9		2.9	4.5	ns
t_r	Differential output signal rise time, CO	$R_L = 100 \Omega$, $C_L = 10 \text{ pF}$, See Figure 10	0.3	0.8	1.5	ns
	Output signal rise time, DCO, DO-n	$C_L = 10 \text{ pF}$, See Figure 11		0.6	1.5	
t_f	Differential output signal fall time, CO	$R_L = 100 \Omega$, $C_L = 10 \text{ pF}$, See Figure 10	0.3	0.8	1.5	ns
	Output signal fall time, DCO, DO-n	$C_L = 10 \text{ pF}$, See Figure 11		0.6	1.5	
$t_{sk(p)}$	Pulse skew ($ t_{PHL} - t_{PLH} $), CO	$R_L = 100 \Omega$, $C_L = 10 \text{ pF}$, See Figure 10		0	300	ps
t_{PZH}	Propagation delay time, high-impedance to high-level output (DCO only)	EN to DCO, DO-n, $C_L = 10 \text{ pF}$, See Figure 12		5	15	ns
t_{PZL}	Propagation delay time, high-impedance to low-level output			5	15	
t_{PHZ}	Propagation delay time, high-level to high-impedance output			5	15	
t_{PLZ}	Propagation delay time, low-level to high-impedance output			6	15	
t_{PZH}	Propagation delay time, high-impedance to high-level output (DCO only)	LVI to DCO, DO-n $C_L = 10 \text{ pF}$, See Figure 12		5	15	ns
t_{PZL}	Propagation delay time, high-impedance to low-level output			5	15	
t_{PHZ}	Propagation delay time, high-level to high-impedance output			5	15	
t_{PLZ}	Propagation delay time, low-level to high-impedance output			5	15	

PARAMETER MEASUREMENT INFORMATION

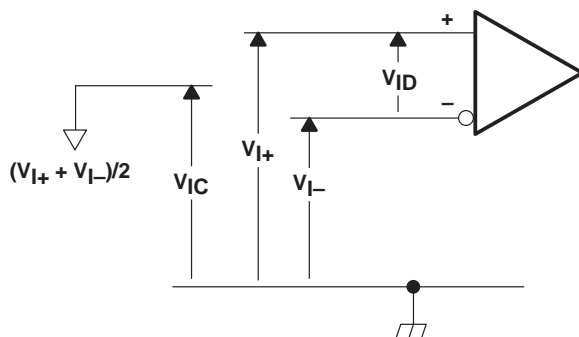

Figure 4. Receiver Voltage Definitions

Table 3. Receiver Minimum and Maximum Input Threshold Test Voltages

APPLIED VOLTAGES		RESULTING DIFFERENTIAL INPUT VOLTAGE	RESULTING COMMON-MODE INPUT VOLTAGE
V _{I+}	V _{I-}	V _{ID}	V _{IC}
1.25 V	1.15 V	100 mV	1.2 V
1.15 V	1.25 V	-100 mV	1.2 V
2.4 V	2.3 V	100 mV	2.35 V
2.3 V	2.4 V	-100 mV	2.35 V
0.1 V	0 V	100 mV	0.05 V
0 V	0.1 V	-100 mV	0.05 V
1.5 V	0.9 V	600 mV	1.2 V
0.9 V	1.5 V	-600 mV	1.2 V
2.4 V	1.8 V	600 mV	2.1 V
1.8 V	2.4 V	-600 mV	2.1 V
0.6 V	0 V	600 mV	0.3 V
0 V	0.6 V	-600 mV	0.3 V

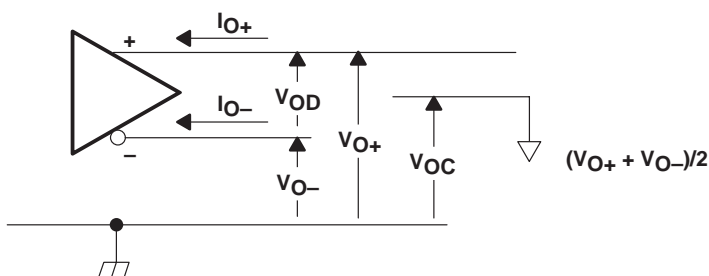

Figure 5. Driver Voltage and Current Definitions

PARAMETER MEASUREMENT INFORMATION

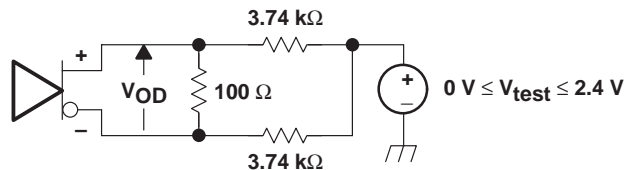
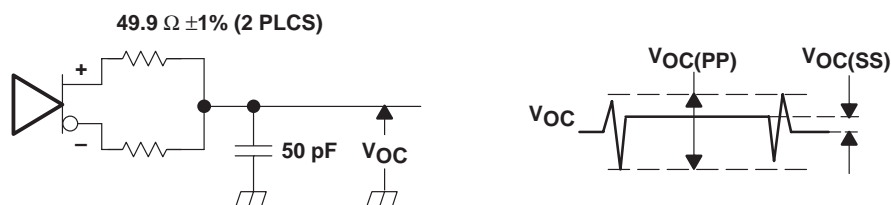

Figure 6. V_{OD} Test Circuit



NOTE A: All input pulses are supplied by a generator having the following characteristics: t_r or $t_f \leq 1$ ns, pulse repetition rate (PRR) = 0.5 Mpps, Pulse width = 500 ± 10 ns. C_L includes instrumentation and fixture capacitance within 0,06 m of the D.U.T. The measurement of $V_{OC(PP)}$ is made on test equipment with a -3 dB bandwidth of at least 5 GHz.

Figure 7. Test Circuit and Definitions for the Driver Common-Mode Output Voltage

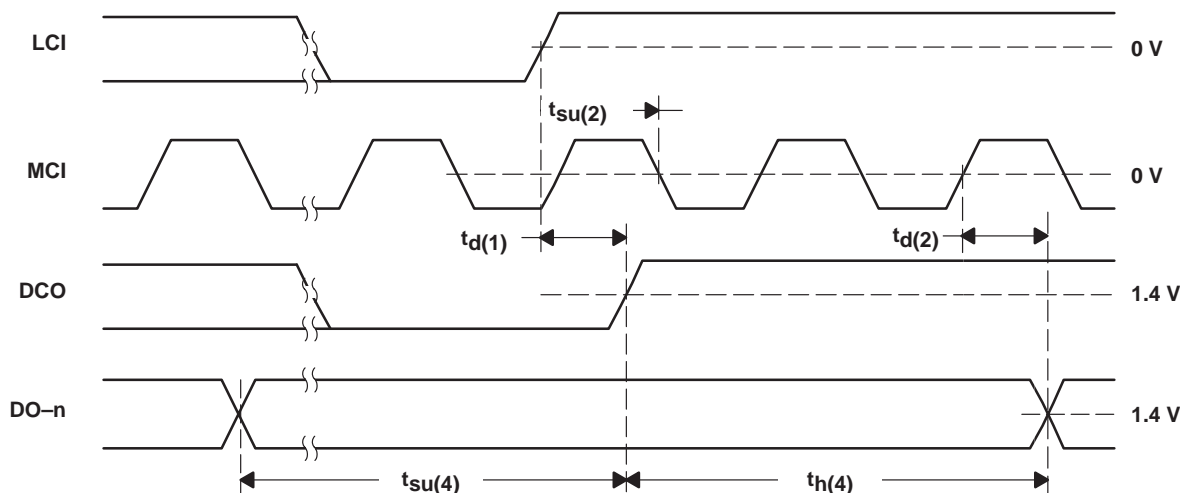

Figure 8. Data Clock and Data Output Timing Waveforms

PARAMETER MEASUREMENT INFORMATION

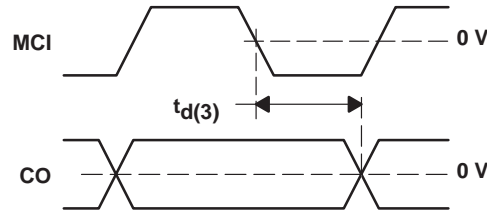
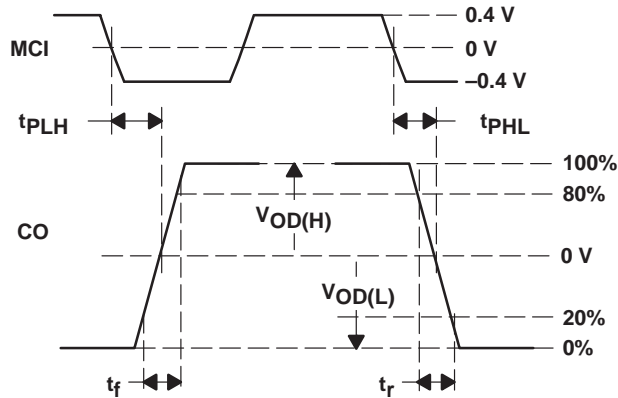
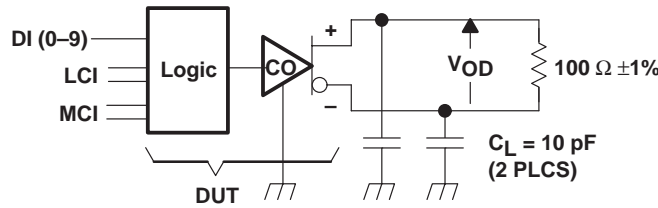
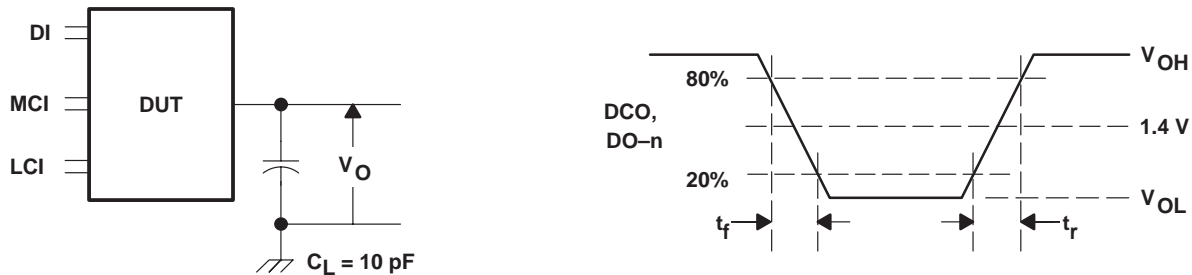

Figure 9. MCI to CO Timing Waveforms



NOTE A: All input pulses are supplied by a generator having the following characteristics: t_r or $t_f \leq 1$ ns, pulse repetition rate (PRR) = 100 Mpps, Pulse width = 5 ± 0.1 ns. C_L includes instrumentation and fixture capacitance within 0,06 m of the D.U.T.

Figure 10. Test Circuit, Timing, and Voltage Definitions for the Differential Output Signal



NOTE A: All input pulses are supplied by a generator having the following characteristics: t_r or $t_f \leq 1$ ns, MCI pulse repetition rate (PRR) = 50 Mpps, Pulse width = 10 ± 0.2 ns. LCI pulse repetition rate (PRR) = 5 Mpps, pulsewidth = 100 ± 2 ns. C_L includes instrumentation and fixture capacitance within 0,06 m of the D.U.T.

Figure 11. Timing Test Circuit and Waveforms

PARAMETER MEASUREMENT INFORMATION

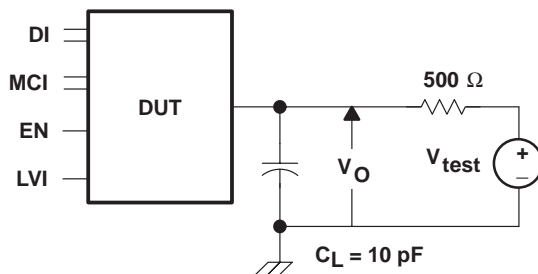

NOTE: $V_{TEST} = 2.5\text{ V}$ for t_{PLZ} or t_{PLZ} , $V_{TEST} = 0\text{ V}$ for t_{PHZ} or t_{PHZ} . All input pulses are supplied by a generator having the following characteristics: t_r or $t_f \leq 1\text{ ns}$, pulse repetition rate (PRR) = 0.5 Mpps, pulse width = $500 \pm 10\text{ ns}$. C_L includes instrumentation and fixture capacitance within 0,06 m of the D.U.T.

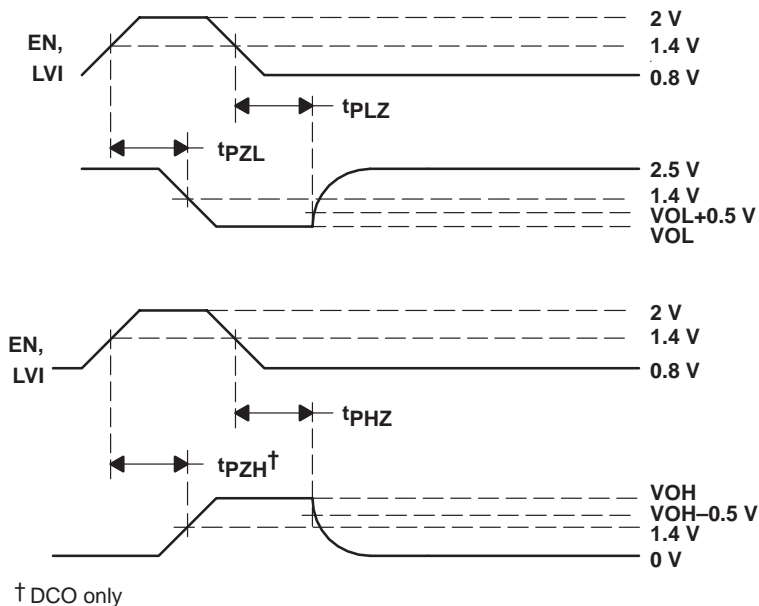

Figure 12. Enable/Disable Time Test Circuit and Waveforms

TYPICAL CHARACTERISTICS

AVERAGE SUPPLY CURRENT
vs
FREQUENCY

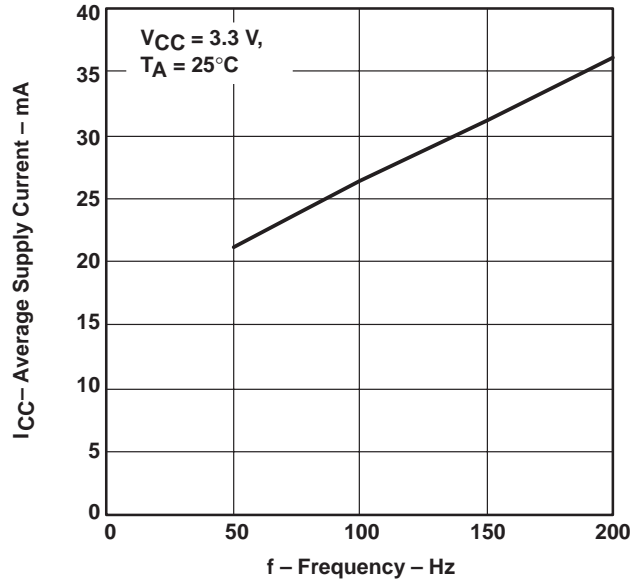

Figure 13. Average Supply Current vs Frequency

MECHANICAL DATA

DA (R-PDSO-G**)

PLASTIC SMALL-OUTLINE

38 PINS SHOWN

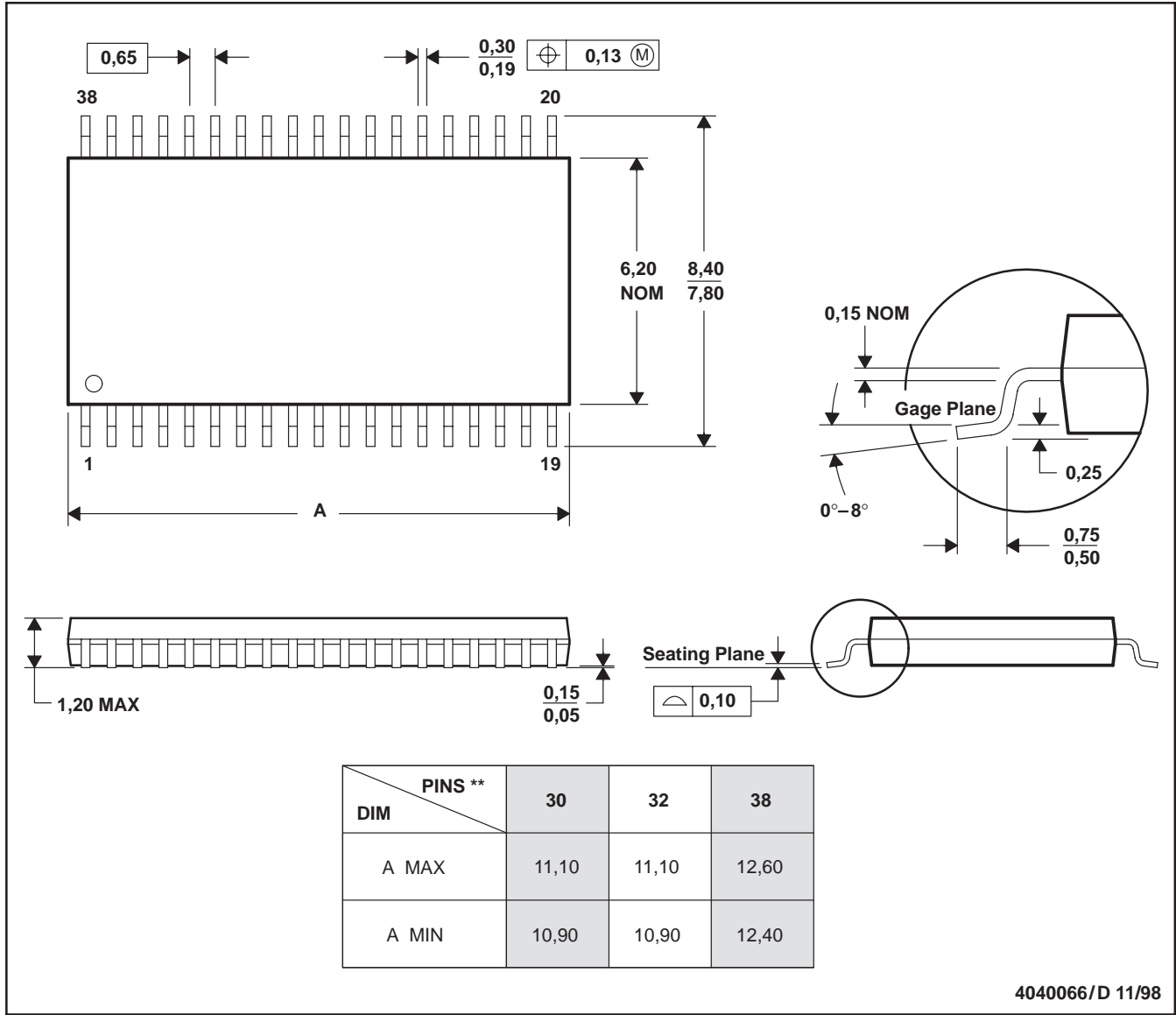

- NOTES: A. All linear dimensions are in millimeters.
 B. This drawing is subject to change without notice.
 C. Body dimensions do not include mold flash or protrusion.
 D. Falls within JEDEC MO-153

PACKAGING INFORMATION

Orderable Device	Status ⁽¹⁾	Package Type	Package Drawing	Pins	Package Qty	Eco Plan ⁽²⁾	Lead/Ball Finish	MSL Peak Temp ⁽³⁾
SN65LVDS152DA	ACTIVE	TSSOP	DA	32	46	None	CU NIPDAU	Level-1-220C-UNLIM
SN65LVDS152DAR	ACTIVE	TSSOP	DA	32	2000	None	CU NIPDAU	Level-1-220C-UNLIM

⁽¹⁾ The marketing status values are defined as follows:

ACTIVE: Product device recommended for new designs.

LIFEBUY: TI has announced that the device will be discontinued, and a lifetime-buy period is in effect.

NRND: Not recommended for new designs. Device is in production to support existing customers, but TI does not recommend using this part in a new design.

PREVIEW: Device has been announced but is not in production. Samples may or may not be available.

OBSOLETE: TI has discontinued the production of the device.

⁽²⁾ Eco Plan - May not be currently available - please check <http://www.ti.com/productcontent> for the latest availability information and additional product content details.

None: Not yet available Lead (Pb-Free).

Pb-Free (RoHS): TI's terms "Lead-Free" or "Pb-Free" mean semiconductor products that are compatible with the current RoHS requirements for all 6 substances, including the requirement that lead not exceed 0.1% by weight in homogeneous materials. Where designed to be soldered at high temperatures, TI Pb-Free products are suitable for use in specified lead-free processes.

Green (RoHS & no Sb/Br): TI defines "Green" to mean "Pb-Free" and in addition, uses package materials that do not contain halogens, including bromine (Br) or antimony (Sb) above 0.1% of total product weight.

⁽³⁾ MSL, Peak Temp. -- The Moisture Sensitivity Level rating according to the JEDEC industry standard classifications, and peak solder temperature.

Important Information and Disclaimer: The information provided on this page represents TI's knowledge and belief as of the date that it is provided. TI bases its knowledge and belief on information provided by third parties, and makes no representation or warranty as to the accuracy of such information. Efforts are underway to better integrate information from third parties. TI has taken and continues to take reasonable steps to provide representative and accurate information but may not have conducted destructive testing or chemical analysis on incoming materials and chemicals. TI and TI suppliers consider certain information to be proprietary, and thus CAS numbers and other limited information may not be available for release.

In no event shall TI's liability arising out of such information exceed the total purchase price of the TI part(s) at issue in this document sold by TI to Customer on an annual basis.

IMPORTANT NOTICE

Texas Instruments Incorporated and its subsidiaries (TI) reserve the right to make corrections, modifications, enhancements, improvements, and other changes to its products and services at any time and to discontinue any product or service without notice. Customers should obtain the latest relevant information before placing orders and should verify that such information is current and complete. All products are sold subject to TI's terms and conditions of sale supplied at the time of order acknowledgment.

TI warrants performance of its hardware products to the specifications applicable at the time of sale in accordance with TI's standard warranty. Testing and other quality control techniques are used to the extent TI deems necessary to support this warranty. Except where mandated by government requirements, testing of all parameters of each product is not necessarily performed.

TI assumes no liability for applications assistance or customer product design. Customers are responsible for their products and applications using TI components. To minimize the risks associated with customer products and applications, customers should provide adequate design and operating safeguards.

TI does not warrant or represent that any license, either express or implied, is granted under any TI patent right, copyright, mask work right, or other TI intellectual property right relating to any combination, machine, or process in which TI products or services are used. Information published by TI regarding third-party products or services does not constitute a license from TI to use such products or services or a warranty or endorsement thereof. Use of such information may require a license from a third party under the patents or other intellectual property of the third party, or a license from TI under the patents or other intellectual property of TI.

Reproduction of information in TI data books or data sheets is permissible only if reproduction is without alteration and is accompanied by all associated warranties, conditions, limitations, and notices. Reproduction of this information with alteration is an unfair and deceptive business practice. TI is not responsible or liable for such altered documentation.

Resale of TI products or services with statements different from or beyond the parameters stated by TI for that product or service voids all express and any implied warranties for the associated TI product or service and is an unfair and deceptive business practice. TI is not responsible or liable for any such statements.

Following are URLs where you can obtain information on other Texas Instruments products and application solutions:

Products		Applications	
Amplifiers	amplifier.ti.com	Audio	www.ti.com/audio
Data Converters	dataconverter.ti.com	Automotive	www.ti.com/automotive
DSP	dsp.ti.com	Broadband	www.ti.com/broadband
Interface	interface.ti.com	Digital Control	www.ti.com/digitalcontrol
Logic	logic.ti.com	Military	www.ti.com/military
Power Mgmt	power.ti.com	Optical Networking	www.ti.com/opticalnetwork
Microcontrollers	microcontroller.ti.com	Security	www.ti.com/security
		Telephony	www.ti.com/telephony
		Video & Imaging	www.ti.com/video
		Wireless	www.ti.com/wireless

Mailing Address: Texas Instruments
Post Office Box 655303 Dallas, Texas 75265