

## HIGH-SPEED DIFFERENTIAL LINE DRIVER

Check for Samples: [SN65LVDS31-EP](#)

### FEATURES

- Meet or Exceed the Requirements of ANSI TIA/EIA-644 Standard
- Low-Voltage Differential Signaling With Typical Output Voltage of 350 mV and 100-Ω Load
- Typical Output Voltage Rise and Fall Times of 500 ps (400 Mbps)
- Typical Propagation Delay Times of 1.7 ns
- Operate From a Single 3.3-V Supply
- Power Dissipation 25 mW Typical Per Driver at 200 MHz
- Driver at High Impedance When Disabled or With  $V_{CC} = 0$
- Bus-Terminal ESD Protection Exceeds 8 kV
- Low-Voltage TTL (LVTTTL) Logic Input Levels
- Pin Compatible With AM26LS31, MC3487, and  $\mu$ A9638
- Cold Sparring for Space and High Reliability Applications Requiring Redundancy

### SUPPORTS DEFENSE, AEROSPACE, AND MEDICAL APPLICATIONS

- Controlled Baseline
- One Assembly/Test Site
- One Fabrication Site
- Available in Military ( $-55^{\circ}\text{C}/125^{\circ}\text{C}$ ) Temperature Range
- Extended Product Life Cycle
- Extended Product-Change Notification
- Product Traceability

**D PACKAGE  
(TOP VIEW)**

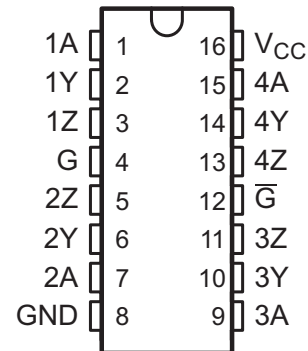

### DESCRIPTION

The SN65LVDS31 is a differential line driver that implements the electrical characteristics of low-voltage differential signaling (LVDS). This signaling technique lowers the output voltage levels of 5-V differential standard levels (such as TIA/EIA-422B) to reduce the power, increase the switching speeds, and allow operation with a 3.3-V supply rail. This driver will deliver a minimum differential output voltage magnitude of 247 mV into a 100-Ω load when enabled.

The intended application of this device and signaling technique is both point-to-point and multidrop (one driver and multiple receivers) data transmission over controlled impedance media of approximately 100 Ω. The transmission media may be printed-circuit board traces, backplanes, or cables. The ultimate rate and distance of data transfer is dependent upon the attenuation characteristics of the media and the noise coupling to the environment.

The SN65LVDS31 is characterized for operation from  $-55^{\circ}\text{C}$  to  $125^{\circ}\text{C}$ .



Please be aware that an important notice concerning availability, standard warranty, and use in critical applications of Texas Instruments semiconductor products and disclaimers thereto appears at the end of this data sheet.



These devices have limited built-in ESD protection. The leads should be shorted together or the device placed in conductive foam during storage or handling to prevent electrostatic damage to the MOS gates.

**ORDERING INFORMATION<sup>(1)</sup>**

T <sub>A</sub>	PACKAGE <sup>(2)</sup>	ORDERABLE PART NUMBER	TOP-SIDE MARKING	VID NUMBER
-55°C to 125°C	SOIC-D	SN65LVDS31MDREP	LVDS31EP	V62/07627-01XE

- (1) For the most current package and ordering information, see the Package Option Addendum at the end of this document, or see the TI website at [www.ti.com](http://www.ti.com).
- (2) Package drawings, standard packing quantities, thermal data, symbolization, and PCB design guidelines are available at [www.ti.com/sc/package](http://www.ti.com/sc/package).

**Logic Symbol**

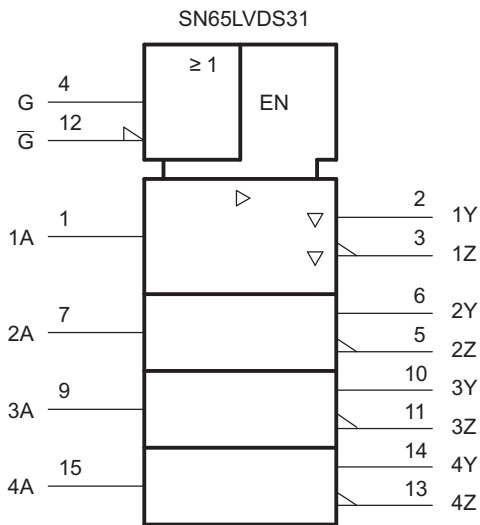

This symbol is in accordance with ANSI/IEEE Std 91-1984 and IEC Publication 617-12.

**SN65LVDS31 Logic Diagram (Positive Logic)**

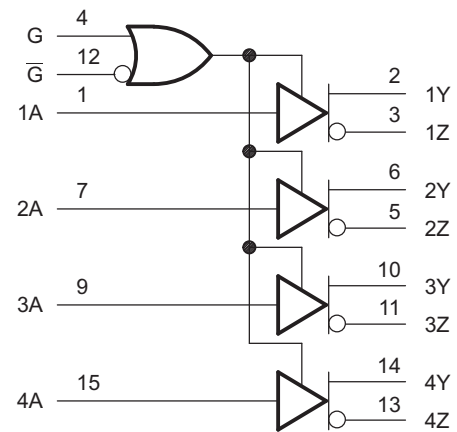

FUNCTION TABLE

Table 1. SN65LVDS31<sup>(1)</sup>

INPUT A	ENABLES		OUTPUTS	
	G	G	Y	Z
H	H	X	H	L
L	H	X	L	H
H	X	L	H	L
L	X	L	L	H
X	L	H	Z	Z
Open	H	X	L	H
Open	X	L	L	H

(1) H = high level, L = low level, X = irrelevant, Z = high impedance (off)

EQUIVALENT INPUT AND OUTPUT SCHEMATIC DIAGRAMS

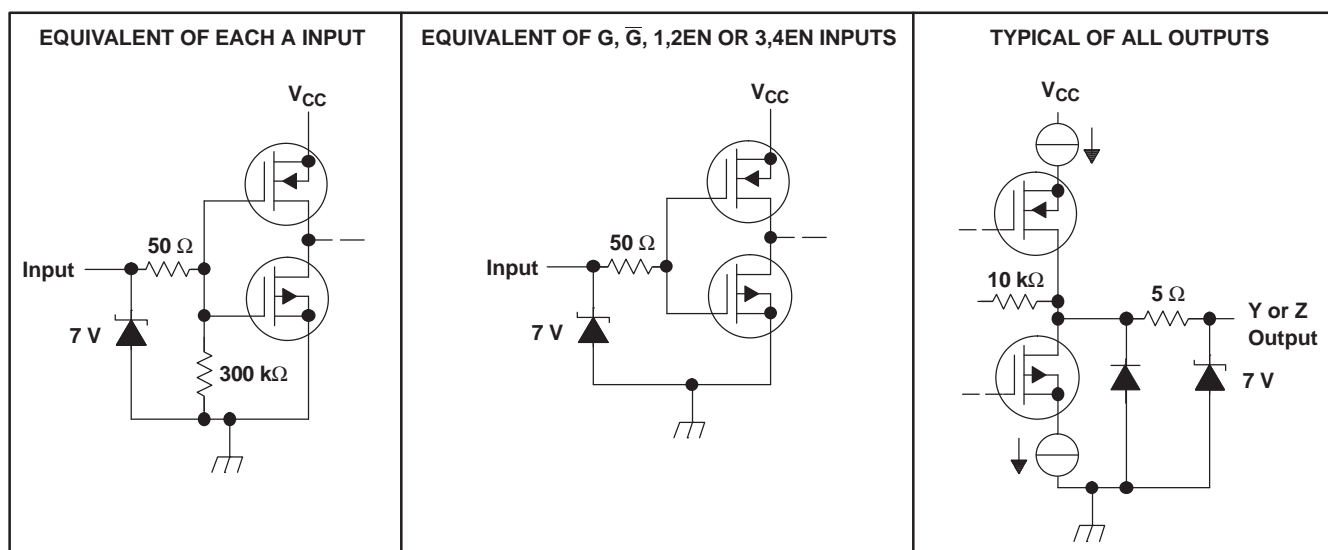

**ABSOLUTE MAXIMUM RATINGS<sup>(1)</sup>**

over operating free-air temperature range (unless otherwise noted)

	UNIT
V <sub>CC</sub> Supply voltage range <sup>(2)</sup>	–0.5 V to 4 V
V <sub>I</sub> Input voltage range	–0.5 V to V <sub>CC</sub> + 0.5 V
Continuous total power dissipation	See Dissipation Rating Table
Lead temperature 1,6 mm (1/16 inch) from case for 10 seconds	260°C
θ <sub>JA</sub> Thermal resistance, junction-to-ambient	73°C/W
θ <sub>JC</sub> Thermal resistance, junction-to-case	36.9°C/W
T <sub>stg</sub> Storage temperature range	–65°C to 150°C

- (1) Stresses beyond those listed under *absolute maximum ratings* may cause permanent damage to the device. These are stress ratings only, and functional operation of the device at these or any other conditions beyond those indicated under *recommended operating conditions* is not implied. Exposure to absolute-maximum-rated conditions for extended periods may affect device reliability.
- (2) All voltages, except differential I/O bus voltages, are with respect to the network ground terminal.

**DISSIPATION RATING TABLE**

PACKAGE	T <sub>A</sub> ≤ 25°C POWER RATING	DERATING FACTOR <sup>(1)</sup> ABOVE T <sub>A</sub> = 25°C	T <sub>A</sub> = 70°C POWER RATING	T <sub>A</sub> = 85°C POWER RATING	T <sub>A</sub> = 125°C POWER RATING
D (16)	950 mW	7.6 mW/°C	608 mW	494 mW	190 mW

- (1) This is the inverse of the junction-to-ambient thermal resistance when board-mounted and with no air flow.

**RECOMMENDED OPERATING CONDITIONS**

	MIN	NOM	MAX	UNIT
V <sub>CC</sub> Supply voltage	3	3.3	3.6	V
V <sub>IH</sub> High-level input voltage	2			V
V <sub>IL</sub> Low-level input voltage			0.8	V
T <sub>A</sub> Operating free-air temperature	–55		125	°C

**ELECTRICAL CHARACTERISTICS**

over operating free-air temperature range (unless otherwise noted)

PARAMETER	TEST CONDITIONS	MIN	TYP <sup>(1)</sup>	MAX	UNIT
V <sub>OD</sub> Differential output voltage magnitude	R <sub>L</sub> = 100 Ω, See Figure 2	247	340	454	mV
ΔV <sub>OD</sub> Change in differential output voltage magnitude between logic states	R <sub>L</sub> = 100 Ω, See Figure 2	–50		50	mV
V <sub>OC(SS)</sub> Steady-state common-mode output voltage	See Figure 3	1.125	1.2	1.375	V
ΔV <sub>OC(SS)</sub> Change in steady-state common-mode output voltage between logic states	See Figure 3	–50		50	mV
V <sub>OC(PP)</sub> Peak-to-peak common-mode output voltage	See Figure 3		50		mV
I <sub>CC</sub> Supply current	V <sub>I</sub> = 0.8 V or 2 V, Enabled, No load		9	20	mA
	V <sub>I</sub> = 0.8 or 2 V, R <sub>L</sub> = 100 Ω, Enabled		25	35	
	V <sub>I</sub> = 0 or V <sub>CC</sub> , Disabled		0.25	1	
I <sub>IH</sub> High-level input current	V <sub>IH</sub> = 2		4	20	μA
I <sub>IL</sub> Low-level input current	V <sub>IL</sub> = 0.8 V		0.1	10	μA
I <sub>OS</sub> Short-circuit output current	V <sub>O(Y)</sub> or V <sub>O(Z)</sub> = 0		–4	–24	mA
	V <sub>OD</sub> = 0			±12	
I <sub>OZ</sub> High-impedance output current	V <sub>O</sub> = 0 or 2.4 V			±1	μA
I <sub>O(OFF)</sub> Power-off output current	V <sub>CC</sub> = 0, V <sub>O</sub> = 2.4 V			±4	μA
C <sub>i</sub> Input capacitance			3		pF

- (1) All typical values are at T<sub>A</sub> = 25°C and with V<sub>CC</sub> = 3.3 V.

## SWITCHING CHARACTERISTICS

over recommended operating conditions (unless otherwise noted)

PARAMETER		TEST CONDITIONS	MIN	TYP <sup>(1)</sup>	MAX	UNIT
$t_{PLH}$	Propagation delay time, low-to-high-level output	$R_L = 100 \Omega$ , $C_L = 10 \text{ pF}$ , See Figure 2	0.5	1.4	4	ns
$t_{PHL}$	Propagation delay time, high-to-low-level output		1	1.7	4.5	ns
$t_r$	Differential output signal rise time (20% to 80%)		0.5			ns
$t_f$	Differential output signal fall time (80% to 20%)		0.5			ns
$t_{sk(p)}$	Pulse skew ( $ t_{PHL} - t_{PLH} $ )		0.3	0.6		ns
$t_{sk(o)}$	Channel-to-channel output skew <sup>(2)</sup>		0.3	0.8		ns
$t_{PZH}$	Propagation delay time, high-impedance-to-high-level output	See Figure 4	5.4	17		ns
$t_{PZL}$	Propagation delay time, high-impedance-to-low-level output		2.5	17		ns
$t_{PHZ}$	Propagation delay time, high-level-to-high-impedance output		8.1	18		ns
$t_{PLZ}$	Propagation delay time, low-level-to-high-impedance output		7.3	17		ns

(1) All typical values are at  $T_A = 25^\circ\text{C}$  and with  $V_{CC} = 3.3 \text{ V}$ .

(2)  $t_{sk(o)}$  is the maximum delay time difference between drivers on the same device.

## PARAMETER MEASUREMENT INFORMATION

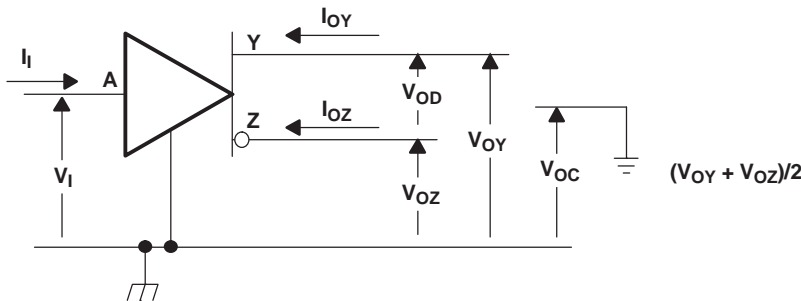
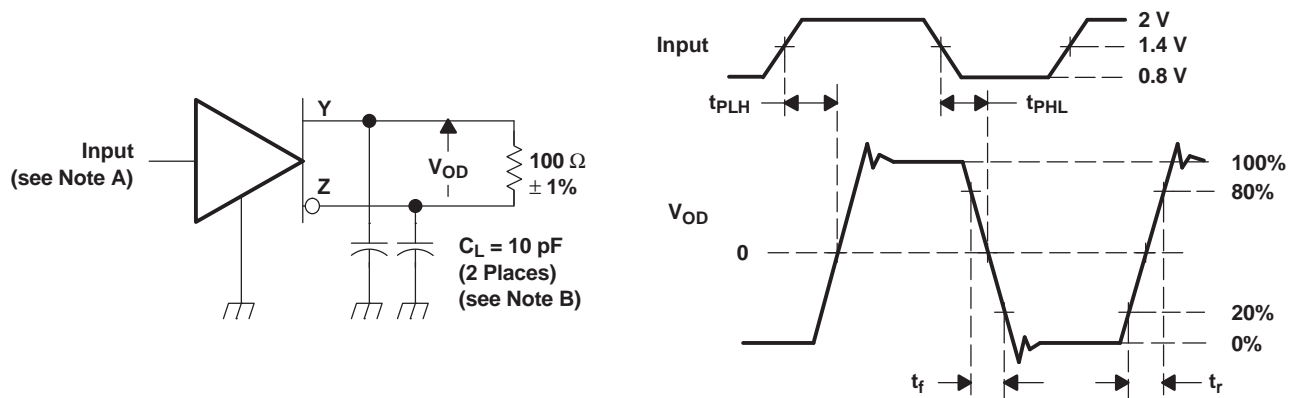

Figure 1. Voltage and Current Definitions



NOTES: A. All input pulses are supplied by a generator having the following characteristics:  $t_r$  or  $t_f \leq 1 \text{ ns}$ , pulse repetition rate (PRR) = 50 Mpps, pulse width =  $10 \pm 0.2 \text{ ns}$ .

B.  $C_L$  includes instrumentation and fixture capacitance within 6 mm of the D.U.T.

Figure 2. Test Circuit, Timing, and Voltage Definitions for the Differential Output Signal

**PARAMETER MEASUREMENT INFORMATION (continued)**

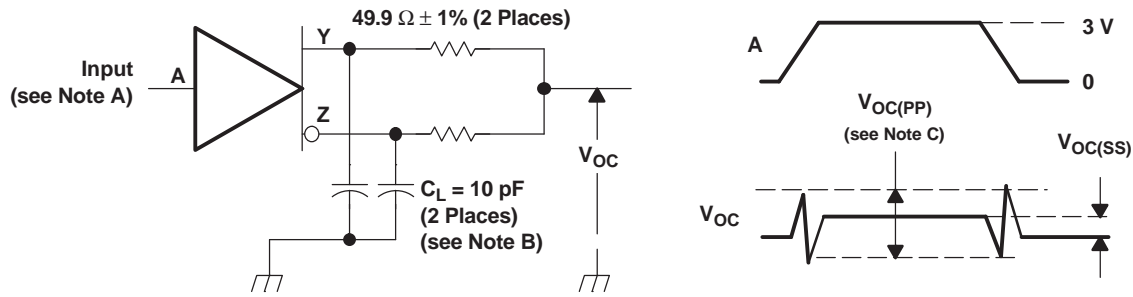

- NOTES: A. All input pulses are supplied by a generator having the following characteristics:  $t_r$  or  $t_f \leq 1$  ns, pulse repetition rate (PRR) = 50 Mpps, pulse width =  $10 \pm 0.2$  ns.  
 B.  $C_L$  includes instrumentation and fixture capacitance within 6 mm of the D.U.T.  
 C. The measurement of  $V_{OC(PP)}$  is made on test equipment with a  $-3$ -dB bandwidth of at least 300 MHz.

**Figure 3. Test Circuit and Definitions for the Driver Common-Mode Output Voltage**

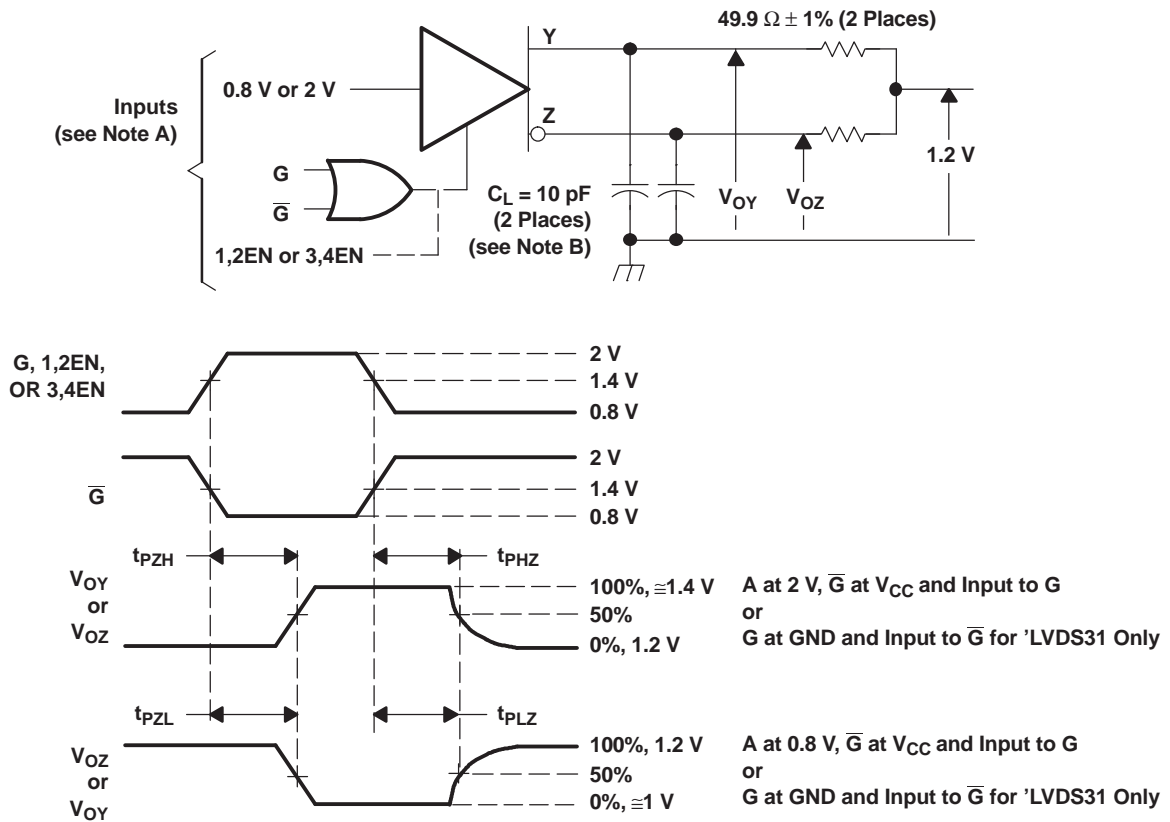

- NOTES: A. All input pulses are supplied by a generator having the following characteristics:  $t_r$  or  $t_f < 1$  ns, pulse repetition rate (PRR) = 0.5 Mpps, pulse width =  $500 \pm 10$  ns.  
 B.  $C_L$  includes instrumentation and fixture capacitance within 6 mm of the D.U.T.

**Figure 4. Enable-/Disable-Time Circuit and Definitions**

TYPICAL CHARACTERISTICS

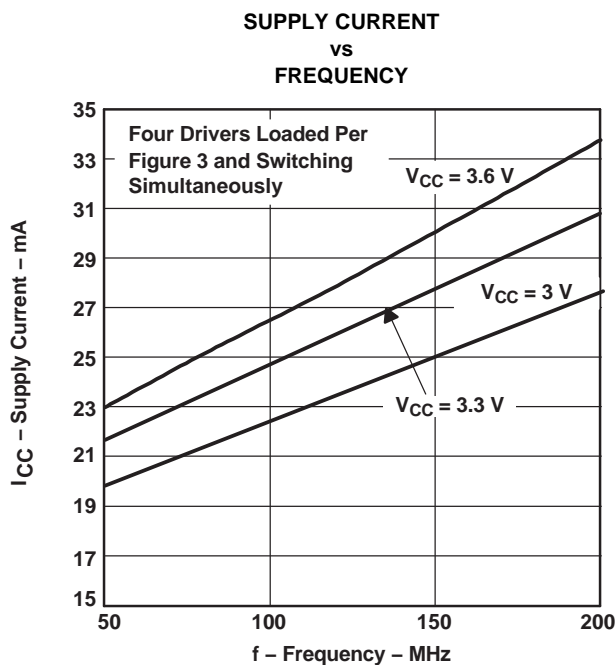

Figure 5.

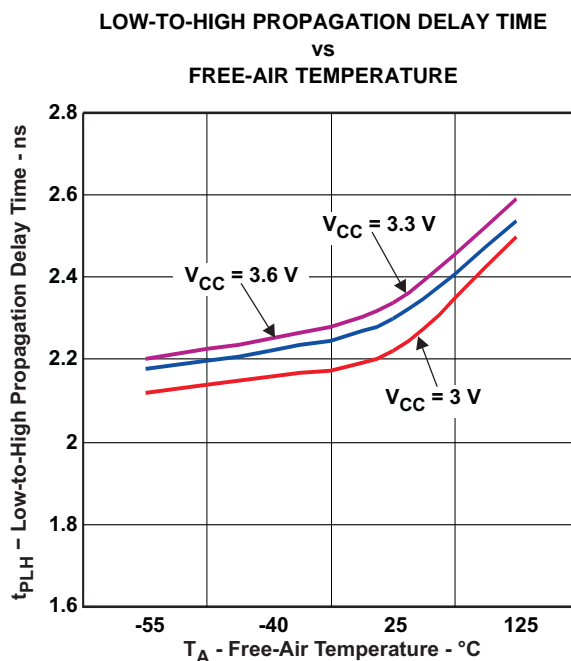

Figure 6.

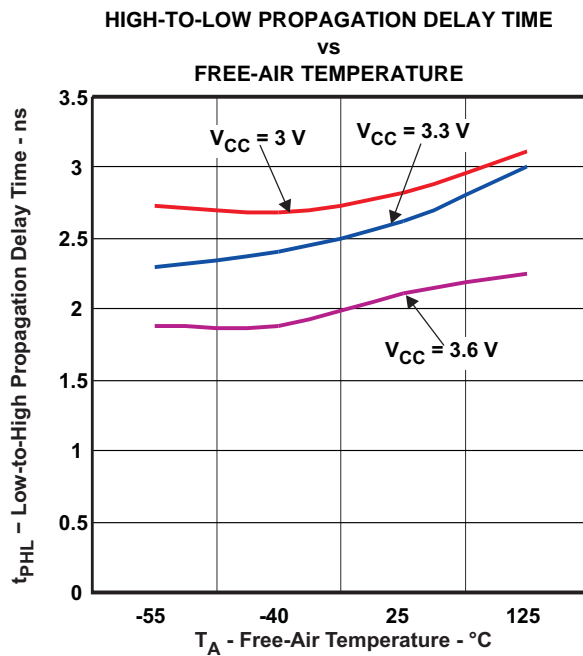
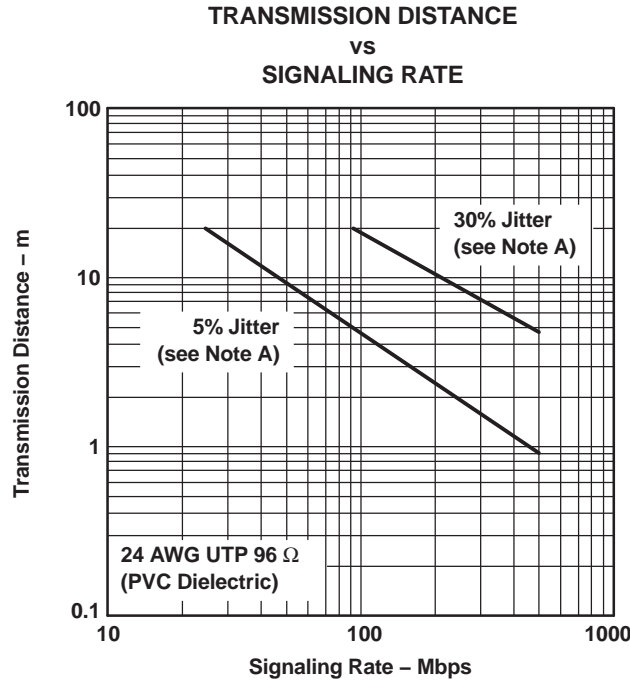

Figure 7.

### APPLICATION INFORMATION

The SN65LVDS31 is generally used as a building block for high-speed point-to-point data transmission where ground differences are less than 1 V. The SN65LVDS31 can interoperate with RS-422, PECL, and IEEE-P1596. Drivers/receivers approach ECL speeds without the power and dual supply requirements.



A. This parameter is the percentage of distortion of the unit interval (UI) with a pseudorandom data pattern.

**Figure 8. Typical Transmission Distance Versus Signaling Rate**

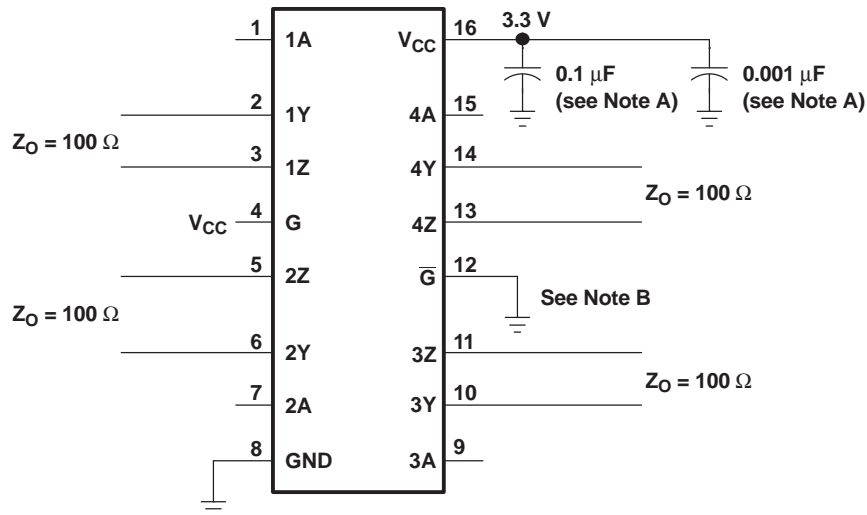

- NOTES: A. Place a 0.1- $\mu$ F and a 0.001- $\mu$ F Z5U ceramic, mica, or polystyrene dielectric, 0805 size, chip capacitor between  $V_{CC}$  and the ground plane. The capacitors should be located as close as possible to the device terminals.  
 B. Unused enable inputs should be tied to  $V_{CC}$  or GND, as appropriate.

**Figure 9. Typical Application Circuit Schematic**

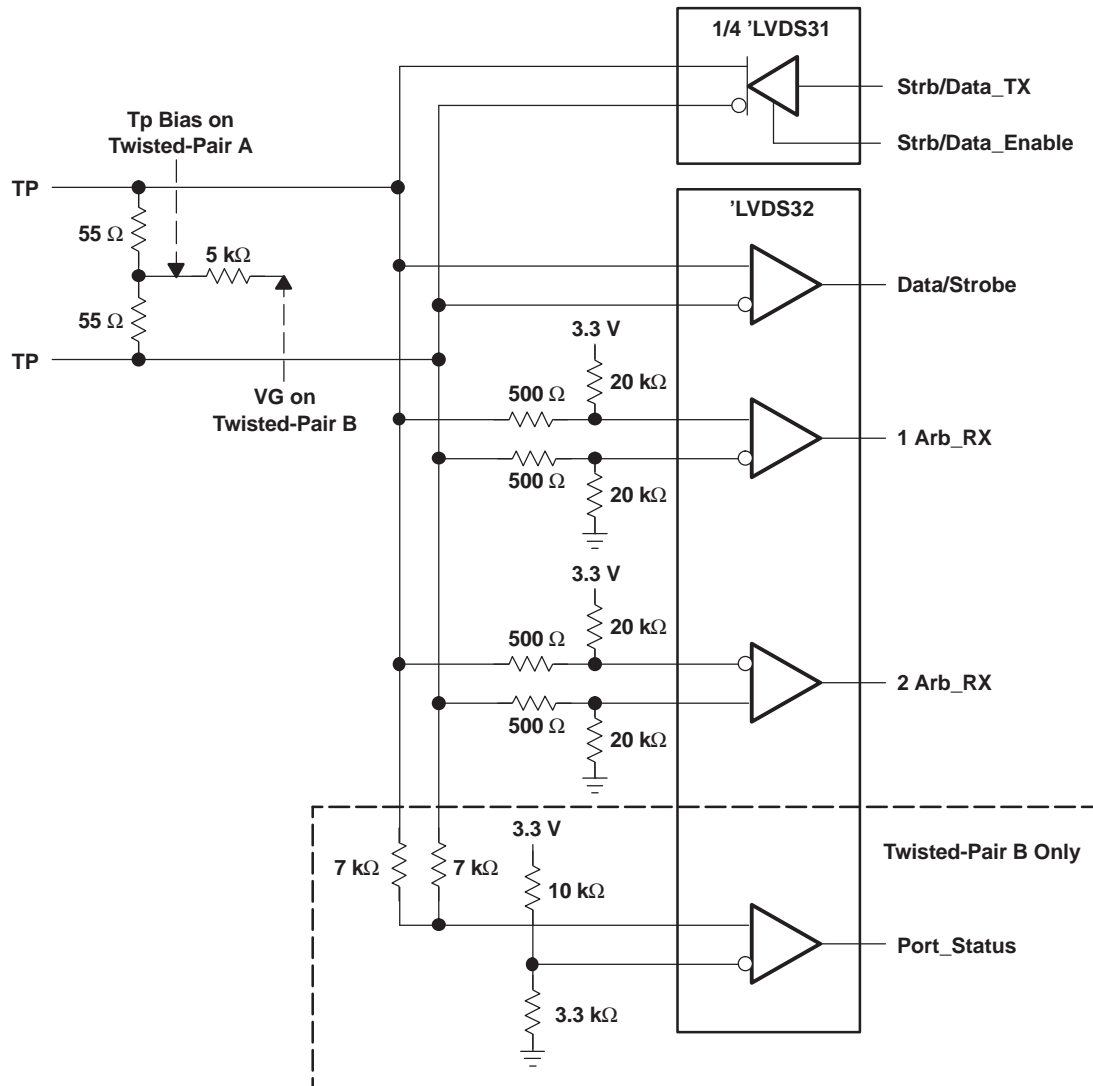

- NOTES: A. Resistors are leadless, thick film (0603), 5% tolerance.  
 B. Decoupling capacitance is not shown, but recommended.  
 C.  $V_{CC}$  is 3 V to 3.6 V.  
 D. The differential output voltage of the 'LVDS31 can exceed that specified by IEEE1394.

Figure 10. 100-Mbps IEEE 1394 Transceiver

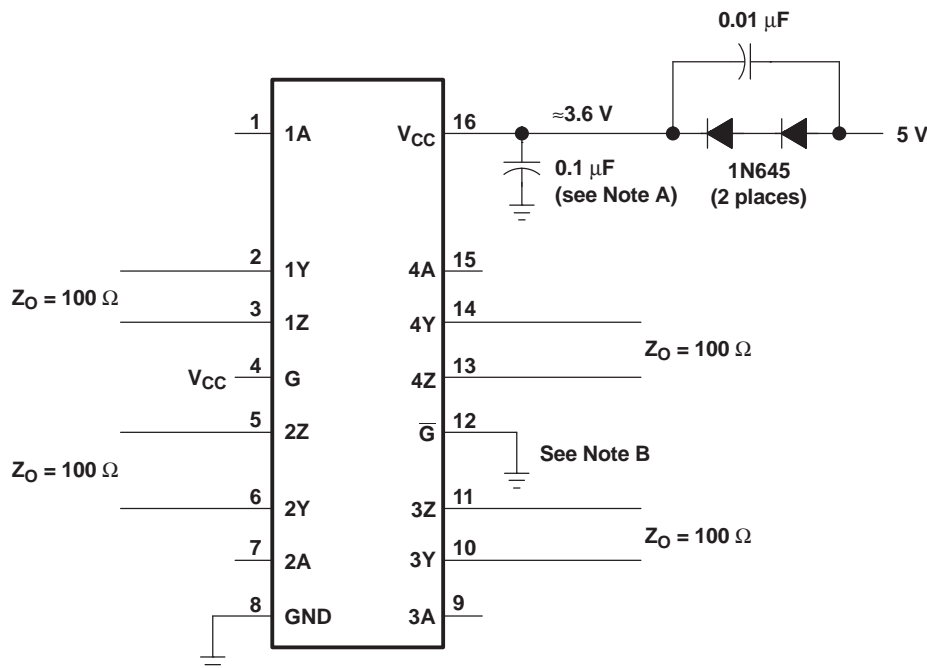

- Place a 0.1-μF Z5U ceramic, mica, or polystyrene dielectric, 0805 size, chip capacitor between  $V_{CC}$  and the ground plane. The capacitor should be located as close as possible to the device terminals.
- Unused enable inputs should be tied to  $V_{CC}$  or GND, as appropriate.

**Figure 11. Operation With 5-V Supply**

## COLD SPARING

Systems using cold sparing have a redundant device electrically connected without power supplied. To support this configuration, the spare must present a high-input impedance to the system so that it does not draw appreciable power. In cold sparing, voltage may be applied to an I/O before and during power up of a device. When the device is powered off,  $V_{CC}$  must be clamped to ground and the I/O voltages applied must be within the specified recommended operating conditions.

## RELATED INFORMATION

IBIS modeling is available for this device. Contact the local TI sales office or the TI Web site at [www.ti.com](http://www.ti.com) for more information.

For more application guidelines, see the following documents:

- *Low-Voltage Differential Signaling Design Notes* ([SLLA014](#))
- *Interface Circuits for TIA/EIA-644 (LVDS)* ([SLLA038](#))
- *Reducing EMI With LVDS* ([SLLA030](#))
- *Slew Rate Control of LVDS Circuits* ([SLLA034](#))
- *Using an LVDS Receiver With RS-422 Data* ([SLLA031](#))
- *Evaluating the LVDS EVM* ([SLLA033](#))

**PACKAGING INFORMATION**

Orderable Device	Status (1)	Package Type	Package Drawing	Pins	Package Qty	Eco Plan (2)	Lead/Ball Finish	MSL Peak Temp (3)	Op Temp (°C)	Top-Side Markings (4)	Samples
SN65LVDS31MDREP	ACTIVE	SOIC	D	16	2500	Green (RoHS & no Sb/Br)	CU NIPDAU	Level-1-260C-UNLIM	-55 to 125	LVDS31EP	Samples

(1) The marketing status values are defined as follows:

**ACTIVE:** Product device recommended for new designs.

**LIFEBUY:** TI has announced that the device will be discontinued, and a lifetime-buy period is in effect.

**NRND:** Not recommended for new designs. Device is in production to support existing customers, but TI does not recommend using this part in a new design.

**PREVIEW:** Device has been announced but is not in production. Samples may or may not be available.

**OBSOLETE:** TI has discontinued the production of the device.

(2) Eco Plan - The planned eco-friendly classification: Pb-Free (RoHS), Pb-Free (RoHS Exempt), or Green (RoHS & no Sb/Br) - please check <http://www.ti.com/productcontent> for the latest availability information and additional product content details.

**TBD:** The Pb-Free/Green conversion plan has not been defined.

**Pb-Free (RoHS):** TI's terms "Lead-Free" or "Pb-Free" mean semiconductor products that are compatible with the current RoHS requirements for all 6 substances, including the requirement that lead not exceed 0.1% by weight in homogeneous materials. Where designed to be soldered at high temperatures, TI Pb-Free products are suitable for use in specified lead-free processes.

**Pb-Free (RoHS Exempt):** This component has a RoHS exemption for either 1) lead-based flip-chip solder bumps used between the die and package, or 2) lead-based die adhesive used between the die and leadframe. The component is otherwise considered Pb-Free (RoHS compatible) as defined above.

**Green (RoHS & no Sb/Br):** TI defines "Green" to mean Pb-Free (RoHS compatible), and free of Bromine (Br) and Antimony (Sb) based flame retardants (Br or Sb do not exceed 0.1% by weight in homogeneous material)

(3) MSL, Peak Temp. -- The Moisture Sensitivity Level rating according to the JEDEC industry standard classifications, and peak solder temperature.

(4) Multiple Top-Side Markings will be inside parentheses. Only one Top-Side Marking contained in parentheses and separated by a "~" will appear on a device. If a line is indented then it is a continuation of the previous line and the two combined represent the entire Top-Side Marking for that device.

**Important Information and Disclaimer:**The information provided on this page represents TI's knowledge and belief as of the date that it is provided. TI bases its knowledge and belief on information provided by third parties, and makes no representation or warranty as to the accuracy of such information. Efforts are underway to better integrate information from third parties. TI has taken and continues to take reasonable steps to provide representative and accurate information but may not have conducted destructive testing or chemical analysis on incoming materials and chemicals. TI and TI suppliers consider certain information to be proprietary, and thus CAS numbers and other limited information may not be available for release.

In no event shall TI's liability arising out of such information exceed the total purchase price of the TI part(s) at issue in this document sold by TI to Customer on an annual basis.

**OTHER QUALIFIED VERSIONS OF SN65LVDS31-EP :**

- Catalog: [SN65LVDS31](#)

NOTE: Qualified Version Definitions:

- Catalog - TI's standard catalog product



## IMPORTANT NOTICE

Texas Instruments Incorporated and its subsidiaries (TI) reserve the right to make corrections, enhancements, improvements and other changes to its semiconductor products and services per JESD46, latest issue, and to discontinue any product or service per JESD48, latest issue. Buyers should obtain the latest relevant information before placing orders and should verify that such information is current and complete. All semiconductor products (also referred to herein as "components") are sold subject to TI's terms and conditions of sale supplied at the time of order acknowledgment.

TI warrants performance of its components to the specifications applicable at the time of sale, in accordance with the warranty in TI's terms and conditions of sale of semiconductor products. Testing and other quality control techniques are used to the extent TI deems necessary to support this warranty. Except where mandated by applicable law, testing of all parameters of each component is not necessarily performed.

TI assumes no liability for applications assistance or the design of Buyers' products. Buyers are responsible for their products and applications using TI components. To minimize the risks associated with Buyers' products and applications, Buyers should provide adequate design and operating safeguards.

TI does not warrant or represent that any license, either express or implied, is granted under any patent right, copyright, mask work right, or other intellectual property right relating to any combination, machine, or process in which TI components or services are used. Information published by TI regarding third-party products or services does not constitute a license to use such products or services or a warranty or endorsement thereof. Use of such information may require a license from a third party under the patents or other intellectual property of the third party, or a license from TI under the patents or other intellectual property of TI.

Reproduction of significant portions of TI information in TI data books or data sheets is permissible only if reproduction is without alteration and is accompanied by all associated warranties, conditions, limitations, and notices. TI is not responsible or liable for such altered documentation. Information of third parties may be subject to additional restrictions.

Resale of TI components or services with statements different from or beyond the parameters stated by TI for that component or service voids all express and any implied warranties for the associated TI component or service and is an unfair and deceptive business practice. TI is not responsible or liable for any such statements.

Buyer acknowledges and agrees that it is solely responsible for compliance with all legal, regulatory and safety-related requirements concerning its products, and any use of TI components in its applications, notwithstanding any applications-related information or support that may be provided by TI. Buyer represents and agrees that it has all the necessary expertise to create and implement safeguards which anticipate dangerous consequences of failures, monitor failures and their consequences, lessen the likelihood of failures that might cause harm and take appropriate remedial actions. Buyer will fully indemnify TI and its representatives against any damages arising out of the use of any TI components in safety-critical applications.

In some cases, TI components may be promoted specifically to facilitate safety-related applications. With such components, TI's goal is to help enable customers to design and create their own end-product solutions that meet applicable functional safety standards and requirements. Nonetheless, such components are subject to these terms.

No TI components are authorized for use in FDA Class III (or similar life-critical medical equipment) unless authorized officers of the parties have executed a special agreement specifically governing such use.

Only those TI components which TI has specifically designated as military grade or "enhanced plastic" are designed and intended for use in military/aerospace applications or environments. Buyer acknowledges and agrees that any military or aerospace use of TI components which have **not** been so designated is solely at the Buyer's risk, and that Buyer is solely responsible for compliance with all legal and regulatory requirements in connection with such use.

TI has specifically designated certain components as meeting ISO/TS16949 requirements, mainly for automotive use. In any case of use of non-designated products, TI will not be responsible for any failure to meet ISO/TS16949.

### Products

Audio	<a href="http://www.ti.com/audio">www.ti.com/audio</a>
Amplifiers	<a href="http://amplifier.ti.com">amplifier.ti.com</a>
Data Converters	<a href="http://dataconverter.ti.com">dataconverter.ti.com</a>
DLP® Products	<a href="http://www.dlp.com">www.dlp.com</a>
DSP	<a href="http://dsp.ti.com">dsp.ti.com</a>
Clocks and Timers	<a href="http://www.ti.com/clocks">www.ti.com/clocks</a>
Interface	<a href="http://interface.ti.com">interface.ti.com</a>
Logic	<a href="http://logic.ti.com">logic.ti.com</a>
Power Mgmt	<a href="http://power.ti.com">power.ti.com</a>
Microcontrollers	<a href="http://microcontroller.ti.com">microcontroller.ti.com</a>
RFID	<a href="http://www.ti-rfid.com">www.ti-rfid.com</a>
OMAP Applications Processors	<a href="http://www.ti.com/omap">www.ti.com/omap</a>
Wireless Connectivity	<a href="http://www.ti.com/wirelessconnectivity">www.ti.com/wirelessconnectivity</a>

### Applications

Automotive and Transportation	<a href="http://www.ti.com/automotive">www.ti.com/automotive</a>
Communications and Telecom	<a href="http://www.ti.com/communications">www.ti.com/communications</a>
Computers and Peripherals	<a href="http://www.ti.com/computers">www.ti.com/computers</a>
Consumer Electronics	<a href="http://www.ti.com/consumer-apps">www.ti.com/consumer-apps</a>
Energy and Lighting	<a href="http://www.ti.com/energy">www.ti.com/energy</a>
Industrial	<a href="http://www.ti.com/industrial">www.ti.com/industrial</a>
Medical	<a href="http://www.ti.com/medical">www.ti.com/medical</a>
Security	<a href="http://www.ti.com/security">www.ti.com/security</a>
Space, Avionics and Defense	<a href="http://www.ti.com/space-avionics-defense">www.ti.com/space-avionics-defense</a>
Video and Imaging	<a href="http://www.ti.com/video">www.ti.com/video</a>

### TI E2E Community

[e2e.ti.com](http://e2e.ti.com)