

SN55LVDS31, SN65LVDS31, SN65LVDS3487, SN65LVDS9638 HIGH-SPEED DIFFERENTIAL LINE DRIVERS

SLLS261J – JULY 1997 – REVISED OCTOBER 2002

- Meet or Exceed the Requirements of ANSI TIA/EIA-644 Standard
- Low-Voltage Differential Signaling With Typical Output Voltage of 350 mV and 100-Ω Load
- Typical Output Voltage Rise and Fall Times of 500 ps (400 Mbps)
- Typical Propagation Delay Times of 1.7 ns
- Operate From a Single 3.3-V Supply
- Power Dissipation 25 mW Typical Per Driver at 200 MHz
- Driver at High Impedance When Disabled or With $V_{CC} = 0$
- Bus-Terminal ESD Protection Exceeds 8 kV
- Low-Voltage TTL (LVTTTL) Logic Input Levels
- Pin Compatible With AM26LS31, MC3487, and μ A9638

description

The SN55LVDS31, SN65LVDS31, SN65LVDS3487, and SN65LVDS9638 are differential line drivers that implement the electrical characteristics of low-voltage differential signaling (LVDS). This signaling technique lowers the output voltage levels of 5-V differential standard levels (such as TIA/EIA-422B) to reduce the power, increase the switching speeds, and allow operation with a 3.3-V supply rail. Any of the four current-mode drivers will deliver a minimum differential output voltage magnitude of 247 mV into a 100-Ω load when enabled.

The intended application of these devices and signaling technique is both point-to-point and multidrop (one driver and multiple receivers) data transmission over controlled impedance media of approximately 100 Ω. The transmission media may be printed-circuit board traces, backplanes, or cables. The ultimate rate and distance of data transfer is dependent upon the attenuation characteristics of the media and the noise coupling to the environment.

The SN65LVDS31, SN65LVDS3487, and SN65LVDS9638 are characterized for operation from -40°C to 85°C. The SN55LVDS31 is characterized for operation from -55°C to 125°C.

SN55LVDS31 . . . J OR W
SN65LVDS31 . . . D OR PW
(Marked as LVDS31 or 65LVDS31)

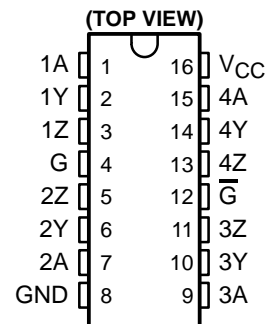

SN55LVDS31FK
(TOP VIEW)

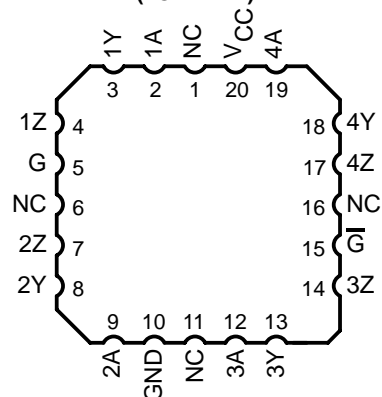

SN65LVDS3487D
(Marked as LVDS3487 or 65LVDS3487)

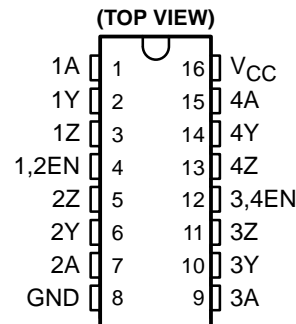

SN65LVDS9638D (Marked as DK638 or LVDS38)
SN65LVDS9638DGN (Marked as L38)
SN65LVDS9638DGK (Marked as AXG)

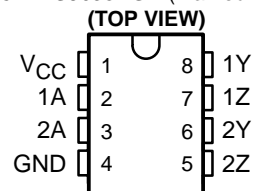

Please be aware that an important notice concerning availability, standard warranty, and use in critical applications of Texas Instruments semiconductor products and disclaimers thereto appears at the end of this data sheet.

PRODUCTION DATA information is current as of publication date. Products conform to specifications per the terms of Texas Instruments standard warranty. Production processing does not necessarily include testing of all parameters.

 **TEXAS
INSTRUMENTS**

POST OFFICE BOX 655303 • DALLAS, TEXAS 75265

Copyright © 2002, Texas Instruments Incorporated
On products compliant to MIL-PRF-38535, all parameters are tested unless otherwise noted. On all other products, production processing does not necessarily include testing of all parameters.

SN55LVDS31, SN65LVDS31, SN65LVDS3487, SN65LVDS9638 HIGH-SPEED DIFFERENTIAL LINE DRIVERS

SLLS261J – JULY 1997 – REVISED OCTOBER 2002

AVAILABLE OPTIONS

T _A	PACKAGE					
	SMALL OUTLINE		MSOP	CHIP CARRIER (FK)	CERAMIC DIP (J)	FLAT PACK (W)
	(D)	(PW)				
-40°C to 85°C	SN65LVDS31D	SN65LVDS31PW	—	—	—	—
	SN65LVDS3487D	—	—	—	—	—
	SN65LVDS9638D	—	SN65LVDS9638DGN	—	—	—
	—	—	SN65LVDS9638DGK	—	—	—
-55°C to 125°C	—	—	—	SNJ55LVDS31FK	SNJ55LVDS31J	SNJ55LVDS31W SN55LVDS31W

logic symbol†

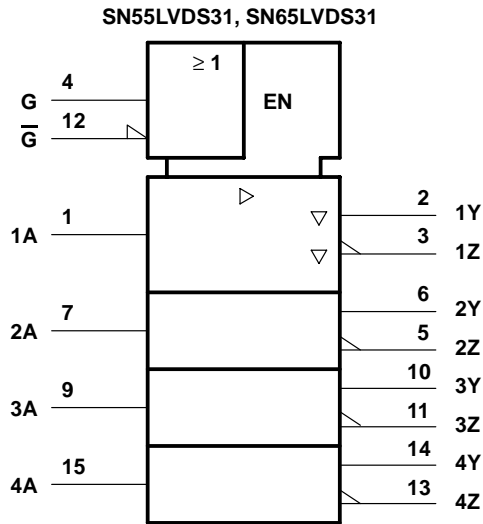

'LVDS31 logic diagram (positive logic)

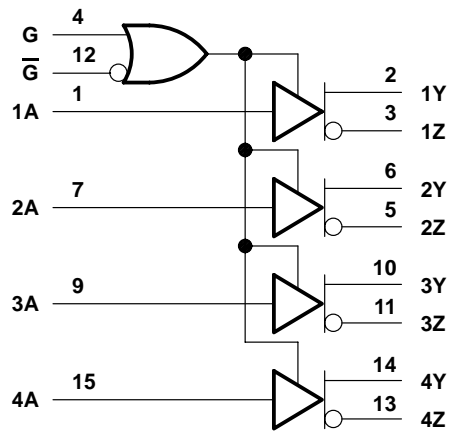

† This symbol is in accordance with ANSI/IEEE Std 91-1984 and IEC Publication 617-12.

logic symbol†

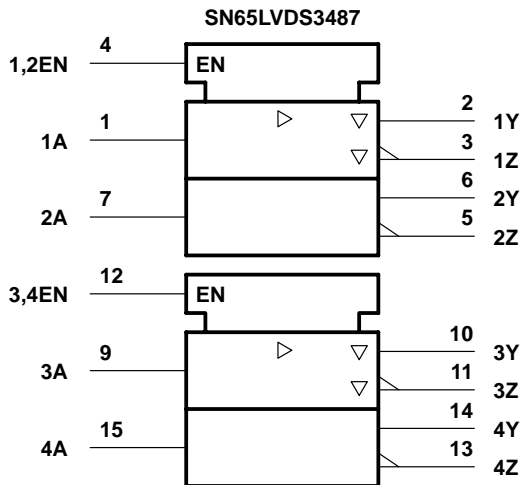

SN65LVDS3487 logic diagram (positive logic)

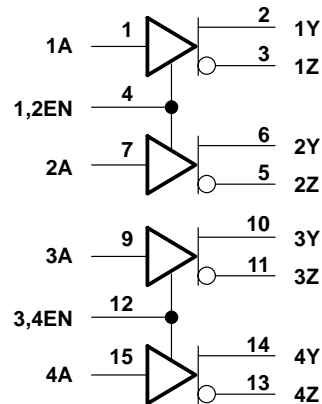

† This symbol is in accordance with ANSI/IEEE Std 91-1984 and IEC Publication 617-12.

SN55LVDS31, SN65LVDS31, SN65LVDS3487, SN65LVDS9638 HIGH-SPEED DIFFERENTIAL LINE DRIVERS

SLLS261J – JULY 1997 – REVISED OCTOBER 2002

logic symbol†

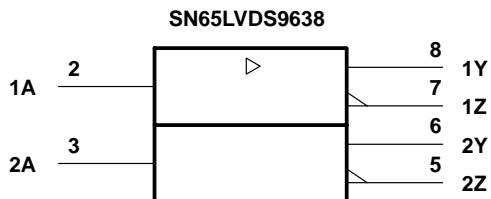

SN65LVDS9638 logic diagram (positive logic)

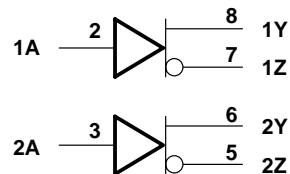

† This symbol is in accordance with ANSI/IEEE Std 91-1984 and IEC Publication 617-12.

Function Tables

SN55LVDS31, SN65LVDS31

INPUT A	ENABLES		OUTPUTS	
	G	G	Y	Z
H	H	X	H	L
L	H	X	L	H
H	X	L	H	L
L	X	L	L	H
X	L	H	Z	Z
Open	H	X	L	H
Open	X	L	L	H

H = high level, L = low level, X = irrelevant, Z = high impedance (off)

SN65LVDS3487

INPUT A	ENABLE EN	OUTPUTS	
		Y	Z
H	H	H	L
L	H	L	H
X	L	Z	Z
Open	H	L	H

H = high level, L = low level, X = irrelevant, Z = high impedance (off)

SN65LVDS9638

INPUT A	OUTPUTS	
	Y	Z
H	H	L
L	L	H
Open	L	H

H = high level, L = low level

SN55LVDS31, SN65LVDS31, SN65LVDS3487, SN65LVDS9638 HIGH-SPEED DIFFERENTIAL LINE DRIVERS

SLLS261J – JULY 1997 – REVISED OCTOBER 2002

equivalent input and output schematic diagrams

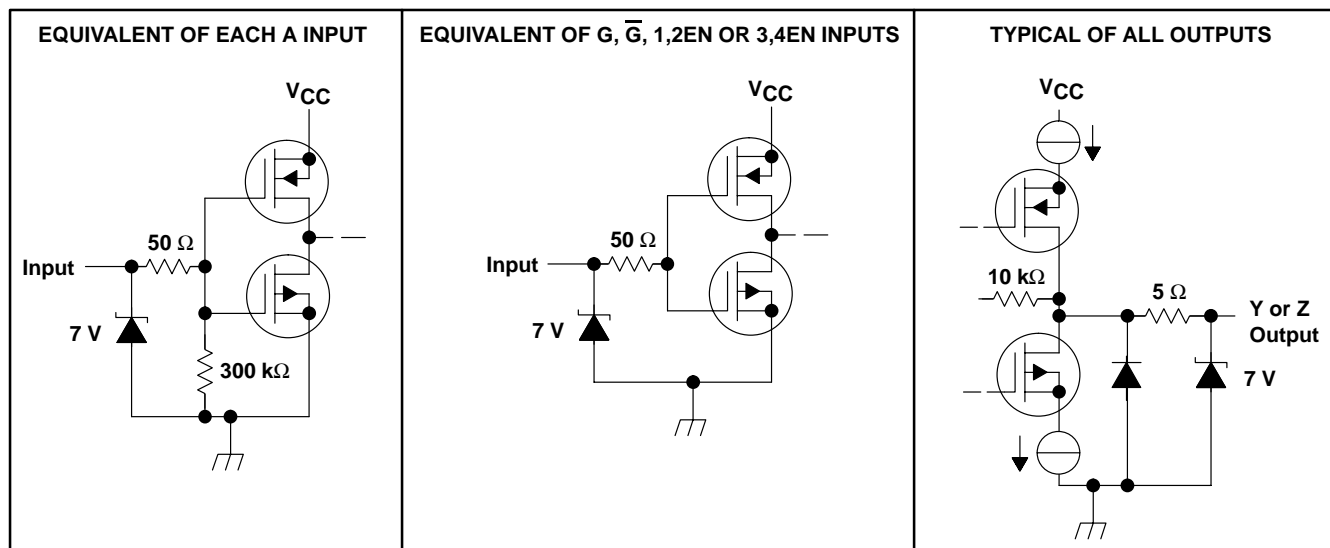

absolute maximum ratings over operating free-air temperature range (unless otherwise noted)†

Supply voltage range, V_{CC} (see Note 1)	-0.5 V to 4 V
Input voltage range, V_I	-0.5 V to $V_{CC} + 0.5$ V
Continuous total power dissipation	See Dissipation Rating Table
Lead temperature 1,6 mm (1/16 inch) from case for 10 seconds	260°C
Storage temperature range, T_{stg}	-65°C to 150°C

† Stresses beyond those listed under “absolute maximum ratings” may cause permanent damage to the device. These are stress ratings only, and functional operation of the device at these or any other conditions beyond those indicated under “recommended operating conditions” is not implied. Exposure to absolute-maximum-rated conditions for extended periods may affect device reliability.

NOTE 1: All voltages, except differential I/O bus voltages, are with respect to the network ground terminal.

DISSIPATION RATING TABLE

PACKAGE	$T_A \leq 25^\circ\text{C}$ POWER RATING	DERATING FACTOR‡ ABOVE $T_A = 25^\circ\text{C}$	$T_A = 70^\circ\text{C}$ POWER RATING	$T_A = 85^\circ\text{C}$ POWER RATING	$T_A = 125^\circ\text{C}$ POWER RATING
D (8)	725 mW	5.8 mW/°C	464 mW	377 mW	—
D (16)	950 mW	7.6 mW/°C	608 mW	494 mW	—
DGK	425 mW	3.4 mW/°C	272 mW	221 mW	—
DGN	2.14 W	17.1 mW/°C	1.37 W	1.11 W	—
FK	1375 mW	11.0 mW/°C	880 mW	715 mW	275 mW
J	1375 mW	11.0 mW/°C	880 mW	715 mW	275 mW
PW (16)	774 mW	6.2 mW/°C	496 mW	402 mW	—
W	1000 mW	8.0 mW/°C	640 mW	520 mW	200 mW

‡ This is the inverse of the junction-to-ambient thermal resistance when board-mounted and with no air flow.

recommended operating conditions

	MIN	NOM	MAX	UNIT
Supply voltage, V_{CC}	3	3.3	3.6	V
High-level input voltage, V_{IH}	2			V
Low-level input voltage, V_{IL}			0.8	V
Operating free-air temperature, T_A	SN65 prefix	-40	85	°C
	SN55 prefix	-55	125	



POST OFFICE BOX 655303 • DALLAS, TEXAS 75265

SN55LVDS31, SN65LVDS31, SN65LVDS3487, SN65LVDS9638 HIGH-SPEED DIFFERENTIAL LINE DRIVERS

SLLS261J – JULY 1997 – REVISED OCTOBER 2002

SN55LVDS31 electrical characteristics over recommended operating conditions (unless otherwise noted)

PARAMETER		TEST CONDITIONS	MIN	TYP†	MAX	UNIT
V _{OD}	Differential output voltage magnitude	R _L = 100 Ω, See Figure 2	247	340	454	mV
ΔV _{OD}	Change in differential output voltage magnitude between logic states	R _L = 100 Ω, See Figure 2	-50		50	mV
V _{OC(SS)}	Steady-state common-mode output voltage	See Figure 3	1.125	1.2	1.375	V
ΔV _{OC(SS)}	Change in steady-state common-mode output voltage between logic states	See Figure 3	-50		50	mV
V _{OC(PP)}	Peak-to-peak common-mode output voltage	See Figure 3		50	150	mV
I _{CC}	Supply current	V _I = 0.8 V or 2 V, Enabled, No load		9	20	mA
		V _I = 0.8 or 2 V, Enabled, R _L = 100 Ω		25	35	
		V _I = 0 or V _{CC} , Disabled		0.25	1	
I _{IH}	High-level input current	V _{IH} = 2		4	20	μA
I _{IL}	Low-level input current	V _{IL} = 0.8 V		0.1	10	μA
I _{OS}	Short-circuit output current	V _{O(Y)} or V _{O(Z)} = 0		-4	-24	mA
		V _{OD} = 0			±12	
I _{OZ}	High-impedance output current	V _O = 0 or 2.4 V			±1	μA
I _{O(OFF)}	Power-off output current	V _{CC} = 0, V _O = 2.4 V			±4	μA
C _i	Input capacitance			3		pF

† All typical values are at T_A = 25°C and with V_{CC} = 3.3 V.

SN55LVDS31 switching characteristics over recommended operating conditions (unless otherwise noted)

PARAMETER		TEST CONDITIONS	MIN	TYP†	MAX	UNIT
t _{PLH}	Propagation delay time, low-to-high-level output	R _L = 100 Ω, C _L = 10 pF, See Figure 2	0.5	1.4	4	ns
t _{PHL}	Propagation delay time, high-to-low-level output		1	1.7	4.5	ns
t _r	Differential output signal rise time (20% to 80%)		0.4	0.5	1	ns
t _f	Differential output signal fall time (80% to 20%)		0.4	0.5	1	ns
t _{sk(p)}	Pulse skew (t _{PHL} - t _{PLH})			0.3	0.6	ns
t _{sk(o)}	Channel-to-channel output skew‡			0.3	0.6	ns
t _{PZH}	Propagation delay time, high-impedance-to-high-level output	See Figure 4		5.4	15	ns
t _{PZL}	Propagation delay time, high-impedance-to-low-level output			2.5	15	ns
t _{PHZ}	Propagation delay time, high-level-to-high-impedance output			8.1	17	ns
t _{PLZ}	Propagation delay time, low-level-to-high-impedance output			7.3	15	ns

† All typical values are at T_A = 25°C and with V_{CC} = 3.3 V.

‡ t_{sk(o)} is the maximum delay time difference between drivers on the same device.



SN55LVDS31, SN65LVDS31, SN65LVDS3487, SN65LVDS9638 HIGH-SPEED DIFFERENTIAL LINE DRIVERS

SLLS261J – JULY 1997 – REVISED OCTOBER 2002

SN65LVDSxxxx electrical characteristics over recommended operating conditions (unless otherwise noted)

PARAMETER		TEST CONDITIONS		SN65LVDS31 SN65LVDS3487 SN65LVDS9638			UNIT
				MIN	TYP†	MAX	
V _{OD}	Differential output voltage magnitude	R _L = 100 Ω,	See Figure 2	247	340	454	mV
ΔV _{OD}	Change in differential output voltage magnitude between logic states	R _L = 100 Ω,	See Figure 2	-50		50	mV
V _{OC(SS)}	Steady-state common-mode output voltage	See Figure 3		1.125	1.2	1.375	V
ΔV _{OC(SS)}	Change in steady-state common-mode output voltage between logic states	See Figure 3		-50		50	mV
V _{OC(PP)}	Peak-to-peak common-mode output voltage	See Figure 3			50	150	mV
I _{CC}	Supply current	SN65LVDS31, SN65LVDS3487	V _I = 0.8 V or 2 V, Enabled, No load		9	20	mA
			V _I = 0.8 or 2 V, Enabled R _L = 100 Ω,		25	35	
			V _I = 0 or V _{CC} , Disabled		0.25	1	
		SN65LVDS9638	V _I = 0.8 V or 2 V, No load		4.7	8	
			R _L = 100 Ω		9	13	
I _{IH}	High-level input current	V _{IH} = 2			4	20	μA
I _{IL}	Low-level input current	V _{IL} = 0.8 V			0.1	10	μA
I _{OS}	Short-circuit output current	V _{O(Y)} or V _{O(Z)} = 0			-4	-24	mA
		V _{OD} = 0				±12	
I _{OZ}	High-impedance output current	V _O = 0 or 2.4 V				±1	μA
I _{O(OFF)}	Power-off output current	V _{CC} = 0,	V _O = 2.4 V			±1	μA
C _i	Input capacitance				3		pF

† All typical values are at T_A = 25°C and with V_{CC} = 3.3 V.



SN55LVDS31, SN65LVDS31, SN65LVDS3487, SN65LVDS9638 HIGH-SPEED DIFFERENTIAL LINE DRIVERS

SLLS261J – JULY 1997 – REVISED OCTOBER 2002

SN65LVDSxxxx switching characteristics over recommended operating conditions (unless otherwise noted)

PARAMETER	TEST CONDITIONS	SN65LVDS31 SN65LVDS3487 SN65LVDS9638			UNIT
		MIN	TYP†	MAX	
t _{PLH} Propagation delay time, low-to-high-level output	R _L = 100 Ω, C _L = 10 pF, See Figure 2	0.5	1.4	2	ns
t _{PHL} Propagation delay time, high-to-low-level output		1	1.7	2.5	ns
t _r Differential output signal rise time (20% to 80%)		0.4	0.5	0.6	ns
t _f Differential output signal fall time (80% to 20%)		0.4	0.5	0.6	ns
t _{sk(p)} Pulse skew (t _{PHL} – t _{PLH})			0.3	0.6	ns
t _{sk(o)} Channel-to-channel output skew‡			0	0.3	ns
t _{sk(pp)} Part-to-part skew§				800	ps
t _{PZH} Propagation delay time, high-impedance-to-high-level output	See Figure 4		5.4	15	ns
t _{PZL} Propagation delay time, high-impedance-to-low-level output			2.5	15	ns
t _{PHZ} Propagation delay time, high-level-to-high-impedance output			8.1	15	ns
t _{PLZ} Propagation delay time, low-level-to-high-impedance output			7.3	15	ns

† All typical values are at T_A = 25°C and with V_{CC} = 3.3 V.

‡ t_{sk(o)} is the skew between specified outputs of a single device with all driving inputs connected together and the outputs switching in the same direction while driving identical specified loads.

§ t_{sk(pp)} is the magnitude of the difference in propagation delay times between any specified terminals of two devices when both devices operate with the same supply voltages, same temperature, and have identical packages and test circuits.



SN55LVDS31, SN65LVDS31, SN65LVDS3487, SN65LVDS9638 HIGH-SPEED DIFFERENTIAL LINE DRIVERS

SLLS261J – JULY 1997 – REVISED OCTOBER 2002

PARAMETER MEASUREMENT INFORMATION

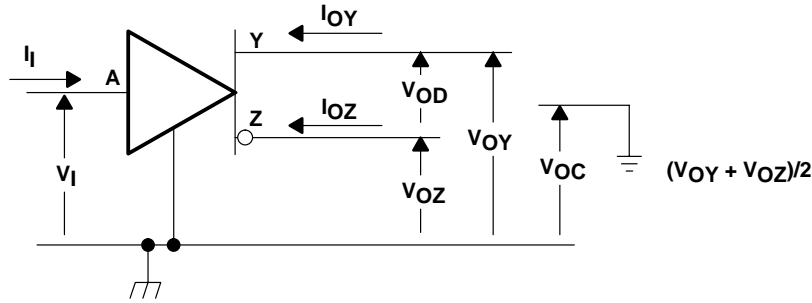
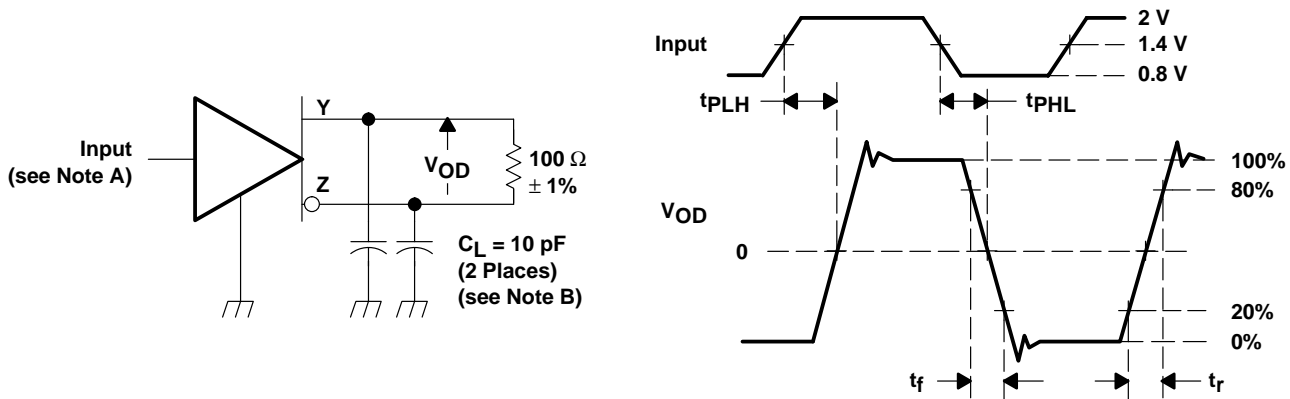
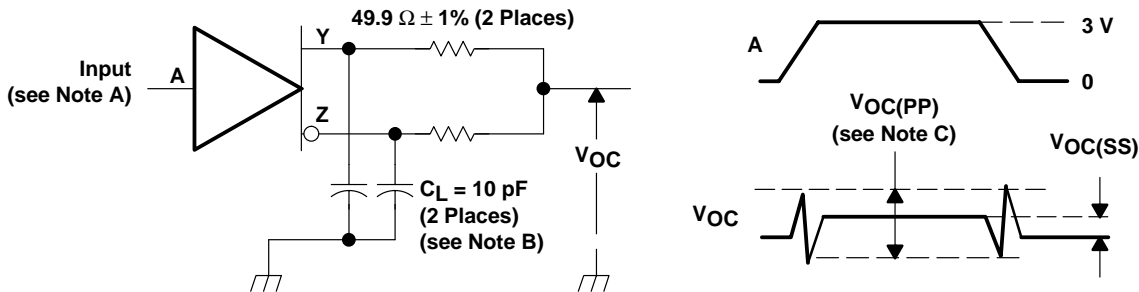

Figure 1. Voltage and Current Definitions



- NOTES: A. All input pulses are supplied by a generator having the following characteristics: t_r or $t_f \leq 1$ ns, pulse repetition rate (PRR) = 50 Mpps, pulse width = 10 ± 0.2 ns.
B. C_L includes instrumentation and fixture capacitance within 6 mm of the D.U.T.

Figure 2. Test Circuit, Timing, and Voltage Definitions for the Differential Output Signal



- NOTES: A. All input pulses are supplied by a generator having the following characteristics: t_r or $t_f \leq 1$ ns, pulse repetition rate (PRR) = 50 Mpps, pulse width = 10 ± 0.2 ns.
B. C_L includes instrumentation and fixture capacitance within 6 mm of the D.U.T.
C. The measurement of $V_{OC(PP)}$ is made on test equipment with a -3 -dB bandwidth of at least 300 MHz.

Figure 3. Test Circuit and Definitions for the Driver Common-Mode Output Voltage

PARAMETER MEASUREMENT INFORMATION

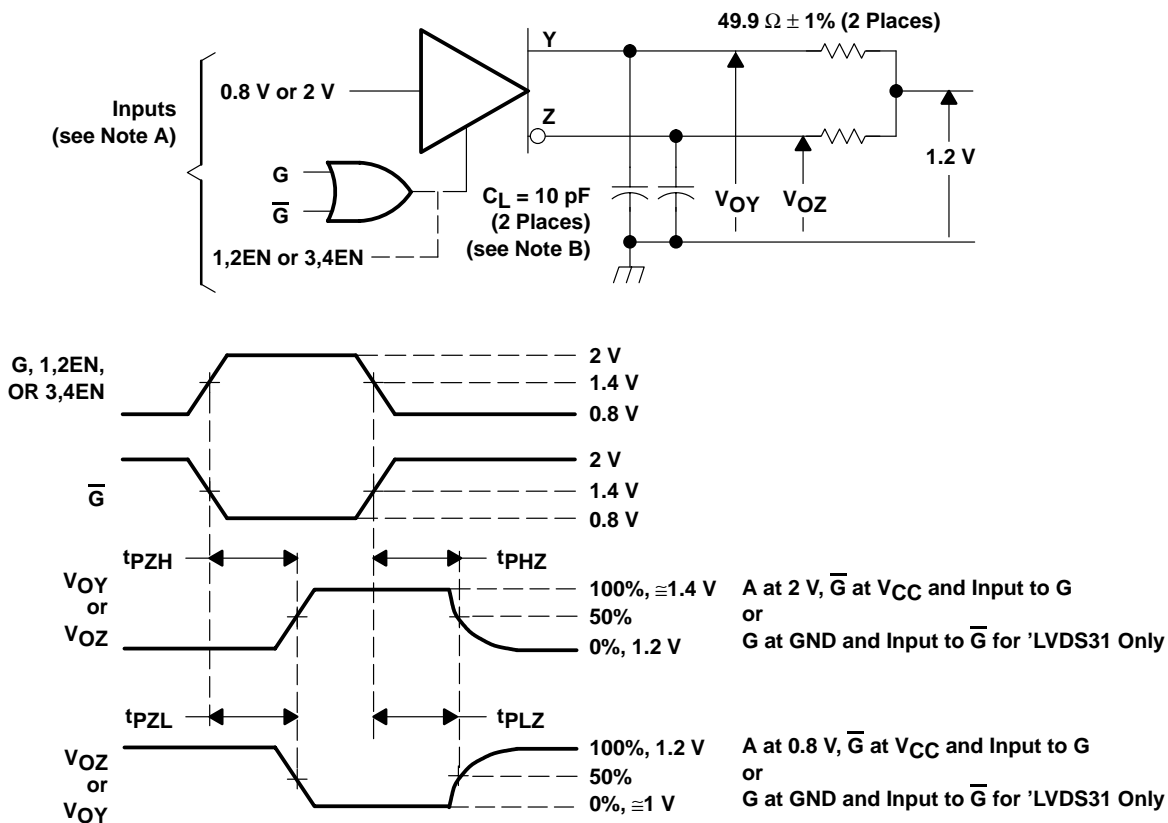

- NOTES: A. All input pulses are supplied by a generator having the following characteristics: t_r or $t_f < 1 \text{ ns}$, pulse repetition rate (PRR) = 0.5 Mpps , pulse width = $500 \pm 10 \text{ ns}$.
B. C_L includes instrumentation and fixture capacitance within 6 mm of the D.U.T.

Figure 4. Enable- and Disable-Time Circuit and Definitions

SN55LVDS31, SN65LVDS31, SN65LVDS3487, SN65LVDS9638 HIGH-SPEED DIFFERENTIAL LINE DRIVERS

SLLS261J – JULY 1997 – REVISED OCTOBER 2002

TYPICAL CHARACTERISTICS

SN55LVDS31, SN65LVDS31
SUPPLY CURRENT
vs
FREQUENCY

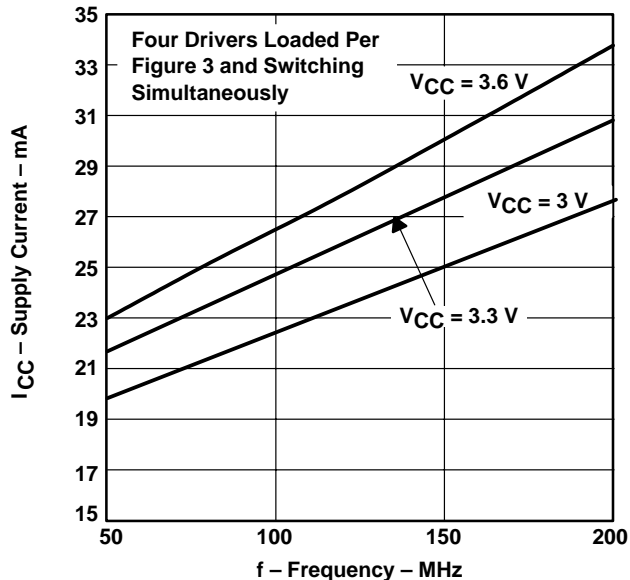

Figure 5

LOW-TO-HIGH PROPAGATION DELAY TIME
vs
FREE-AIR TEMPERATURE

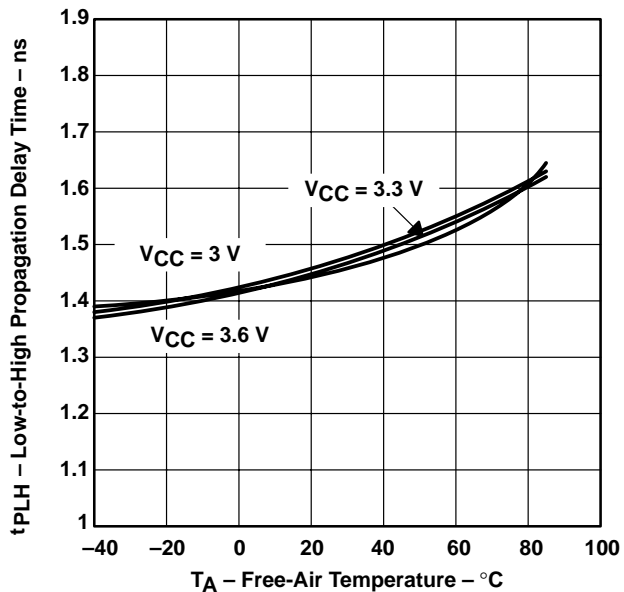

Figure 6

HIGH-TO-LOW PROPAGATION DELAY TIME
vs
FREE-AIR TEMPERATURE

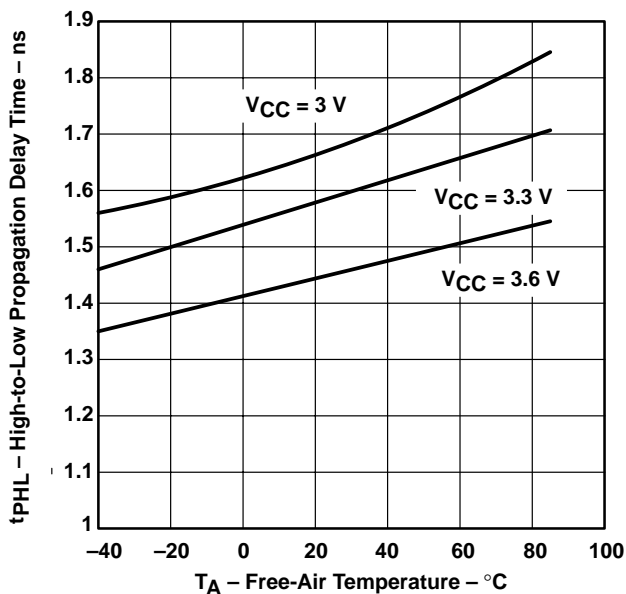
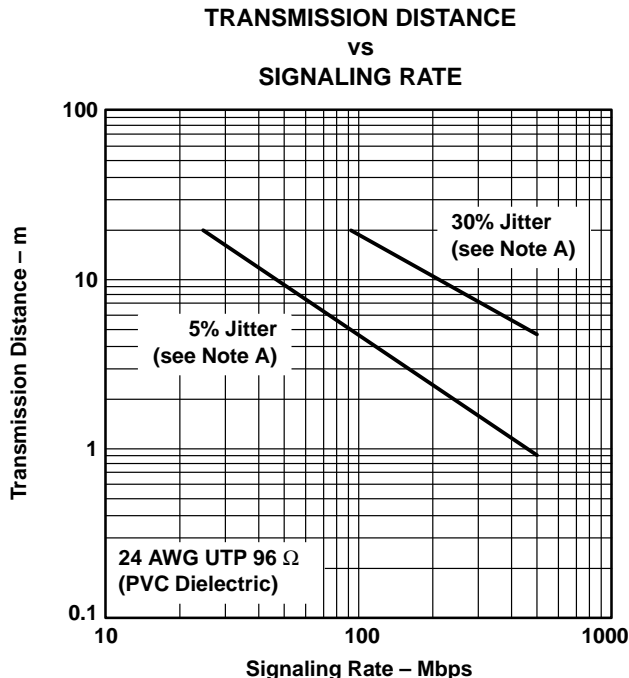

Figure 7



APPLICATION INFORMATION

The devices are generally used as building blocks for high-speed point-to-point data transmission where ground differences are less than 1 V. Devices can interoperate with RS-422, PECL, and IEEE-P1596. Drivers/receivers approach ECL speeds without the power and dual supply requirements.



NOTE A: This parameter is the percentage of distortion of the unit interval (UI) with a pseudorandom data pattern.

Figure 8. Typical Transmission Distance Versus Signaling Rate

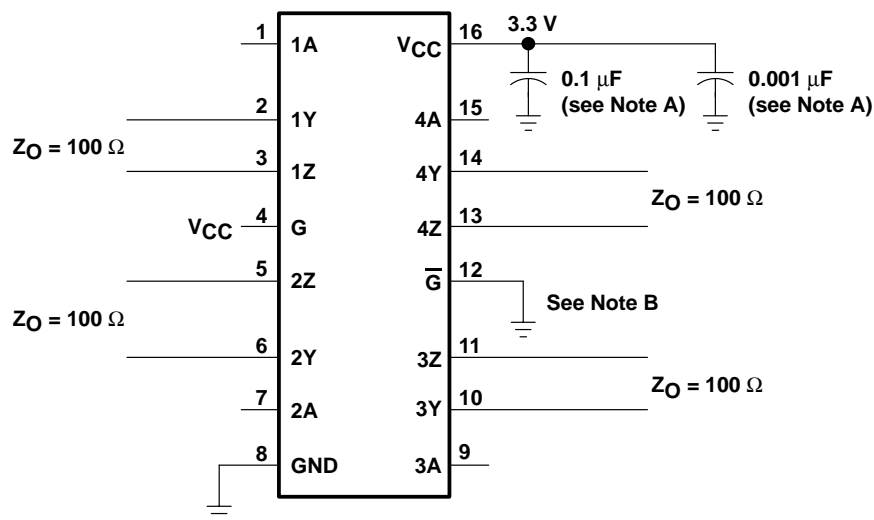

NOTES: A. Place a 0.1- μ F and a 0.001- μ F Z5U ceramic, mica, or polystyrene dielectric, 0805 size, chip capacitor between V_{CC} and the ground plane. The capacitors should be located as close as possible to the device terminals.
B. Unused enable inputs should be tied to V_{CC} or GND, as appropriate.

Figure 9. Typical Application Circuit Schematic

SN55LVDS31, SN65LVDS31, SN65LVDS3487, SN65LVDS9638 HIGH-SPEED DIFFERENTIAL LINE DRIVERS

SLLS261J – JULY 1997 – REVISED OCTOBER 2002

APPLICATION INFORMATION

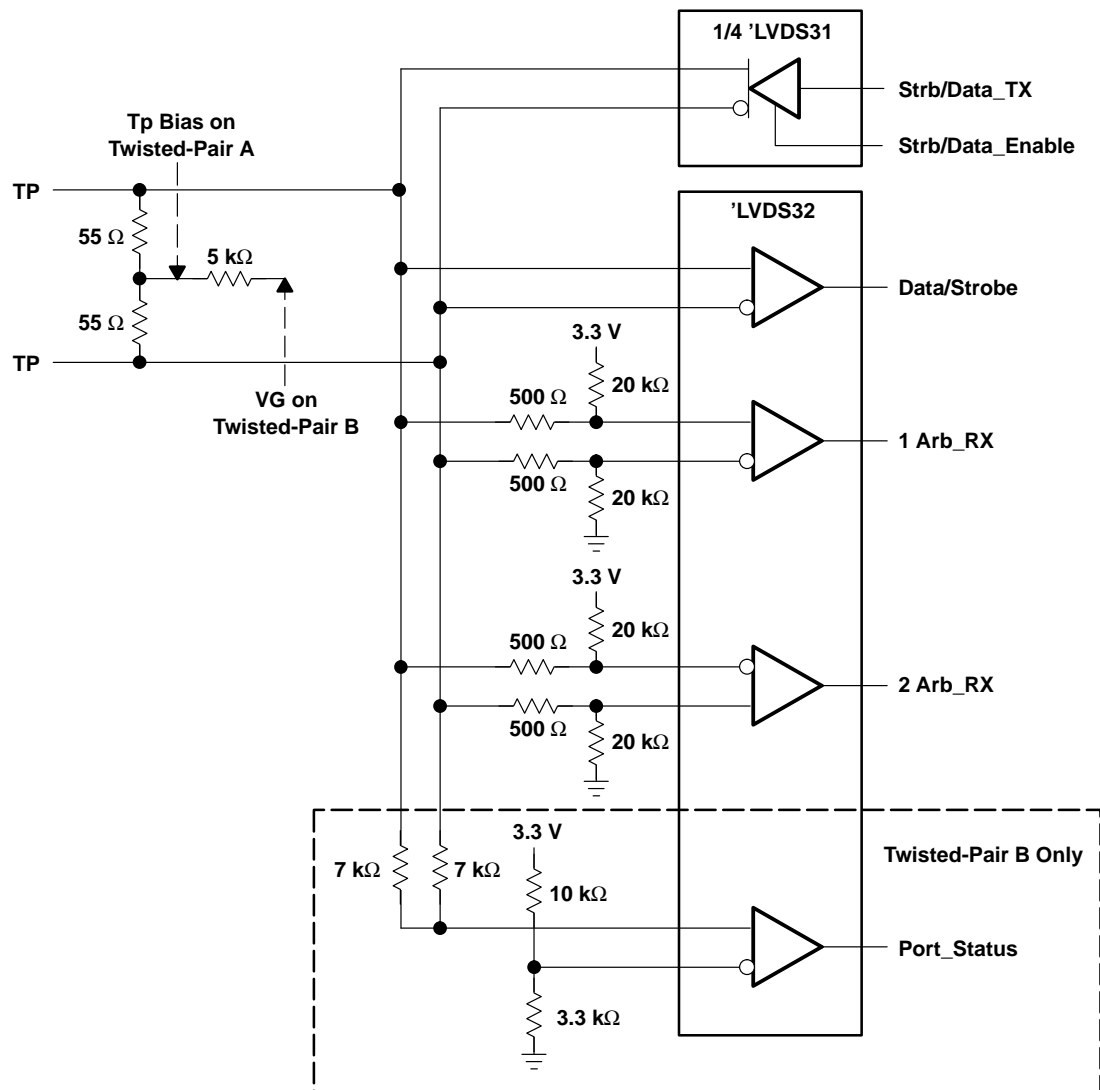

- NOTES:
- A. Resistors are leadless, thick film (0603), 5% tolerance.
 - B. Decoupling capacitance is not shown, but recommended.
 - C. V_{CC} is 3 V to 3.6 V.
 - D. The differential output voltage of the 'LVDS31 can exceed that specified by IEEE1394.

Figure 10. 100-Mbps IEEE 1394 Transceiver

APPLICATION INFORMATION

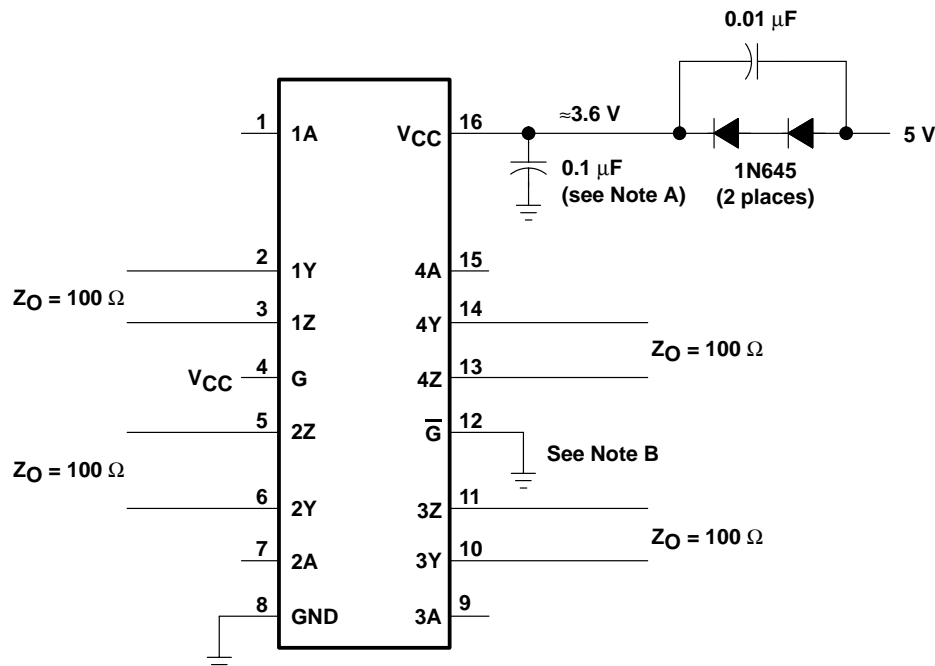

NOTES: A. Place a 0.1- μ F Z5U ceramic, mica, or polystyrene dielectric, 0805 size, chip capacitor between V_{CC} and the ground plane. The capacitor should be located as close as possible to the device terminals.
B. Unused enable inputs should be tied to V_{CC} or GND, as appropriate.

Figure 11. Operation With 5-V Supply

related information

IBIS modeling is available for this device. Please contact the local TI sales office or the TI Web site at www.ti.com for more information.

For more application guidelines, please see the following documents:

- *Low-Voltage Differential Signaling Design Notes* (literature number SLLA014)
- *Interface Circuits for TIA/EIA-644 (LVDS)* (literature number SLLA038)
- *Reducing EMI With LVDS* (literature number SLLA030)
- *Slew Rate Control of LVDS Circuits* (literature number SLLA034)
- *Using an LVDS Receiver With RS-422 Data* (literature number SLLA031)
- *Evaluating the LVDS EVM* (literature number SLLA033)

SN55LVDS31, SN65LVDS31, SN65LVDS3487, SN65LVDS9638 HIGH-SPEED DIFFERENTIAL LINE DRIVERS

SLLS261J – JULY 1997 – REVISED OCTOBER 2002

MECHANICAL INFORMATION

D (R-PDSO-G**)

PLASTIC SMALL-OUTLINE PACKAGE

14 PIN SHOWN

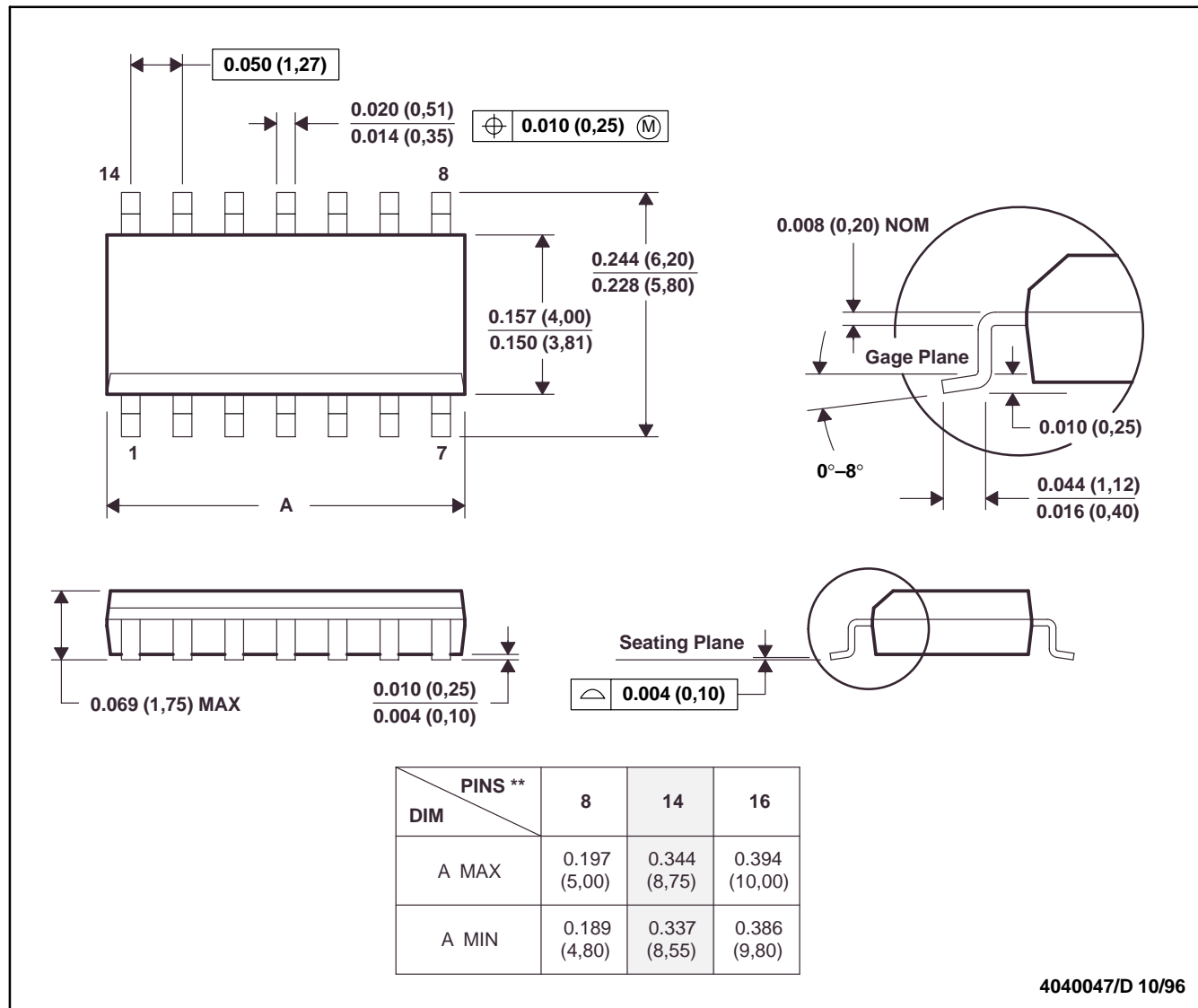

- NOTES: A. All linear dimensions are in inches (millimeters).
 B. This drawing is subject to change without notice.
 C. Body dimensions do not include mold flash or protrusion, not to exceed 0.006 (0,15).
 D. Falls within JEDEC MS-012

SN55LVDS31, SN65LVDS31, SN65LVDS3487, SN65LVDS9638 HIGH-SPEED DIFFERENTIAL LINE DRIVERS

SLLS261J – JULY 1997 – REVISED OCTOBER 2002

MECHANICAL INFORMATION

DGK (R-PDSO-G8)

PLASTIC SMALL-OUTLINE PACKAGE

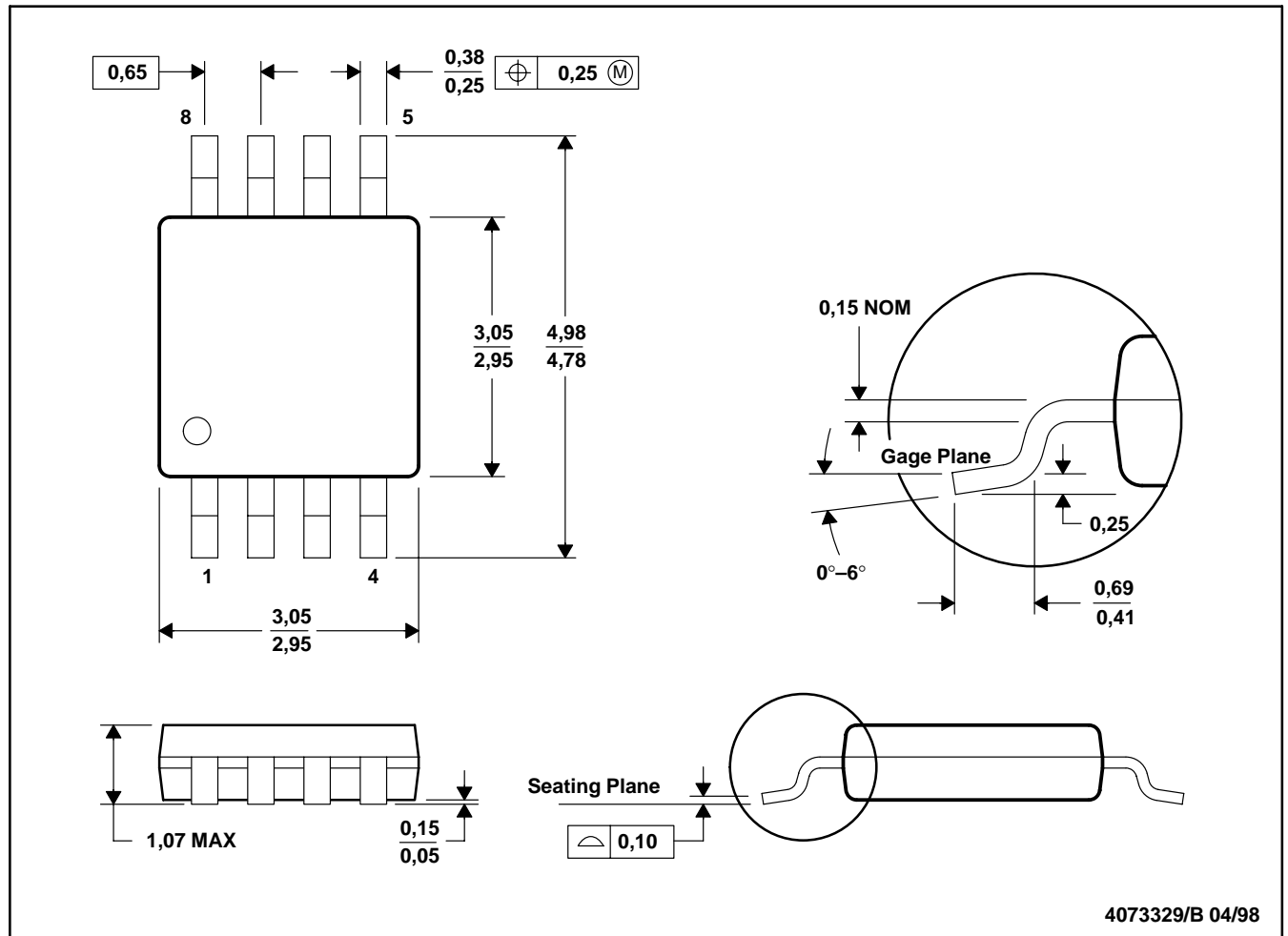

4073329/B 04/98

- NOTES:
- All linear dimensions are in millimeters.
 - This drawing is subject to change without notice.
 - Body dimensions do not include mold flash or protrusion.
 - Falls within JEDEC MO-187

SN55LVDS31, SN65LVDS31, SN65LVDS3487, SN65LVDS9638 HIGH-SPEED DIFFERENTIAL LINE DRIVERS

SLLS261J – JULY 1997 – REVISED OCTOBER 2002

MECHANICAL INFORMATION

FK (S-CQCC-N**)

LEADLESS CERAMIC CHIP CARRIER

28 TERMINAL SHOWN

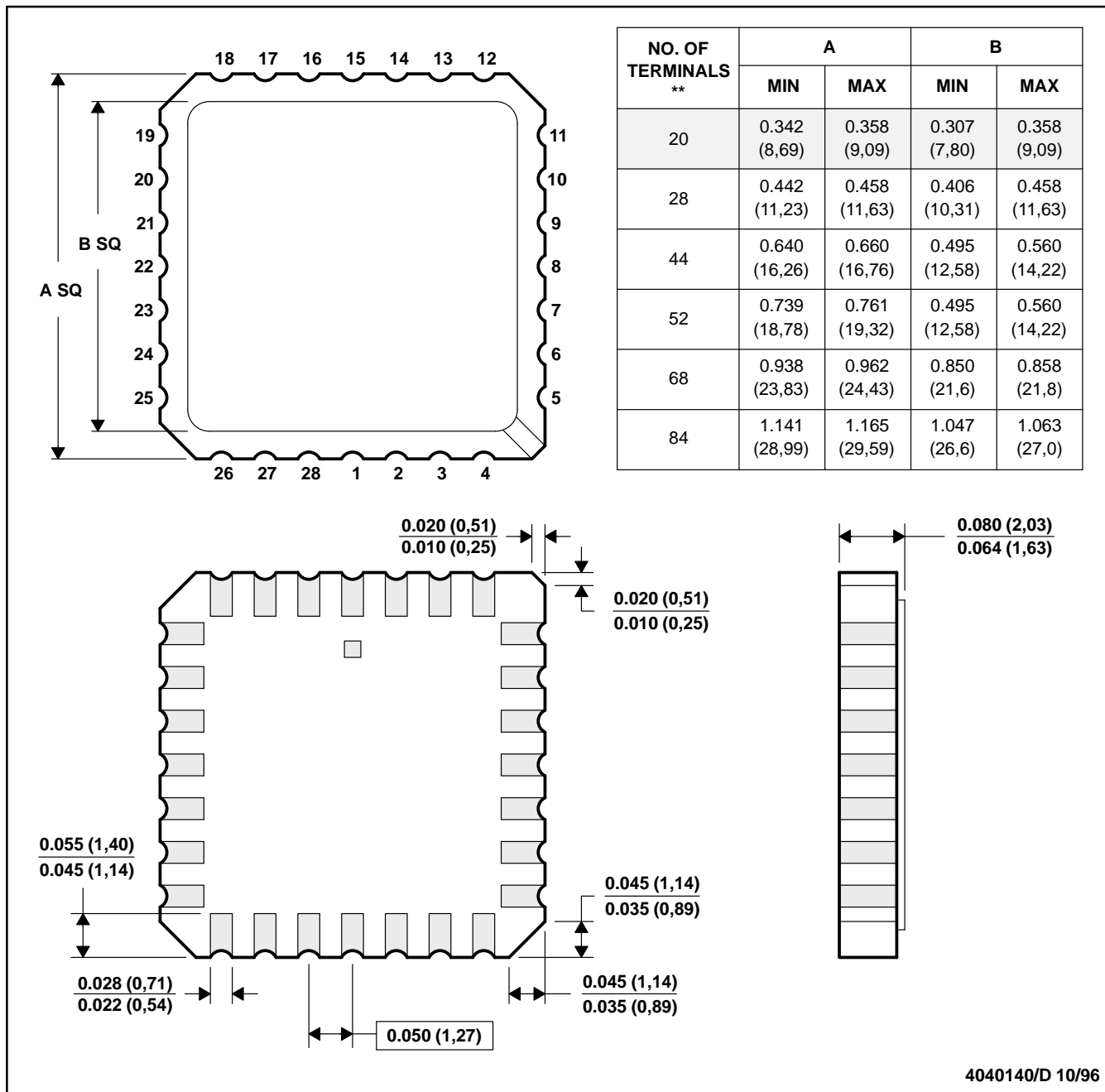

- NOTES:
- A. All linear dimensions are in inches (millimeters).
 - B. This drawing is subject to change without notice.
 - C. This package can be hermetically sealed with a metal lid.
 - D. The terminals are gold plated.
 - E. Falls within JEDEC MS-004

SN55LVDS31, SN65LVDS31, SN65LVDS3487, SN65LVDS9638 HIGH-SPEED DIFFERENTIAL LINE DRIVERS

SLLS261J – JULY 1997 – REVISED OCTOBER 2002

MECHANICAL INFORMATION

J (R-GDIP-T)**
14 PIN SHOWN

CERAMIC DUAL-IN-LINE PACKAGE

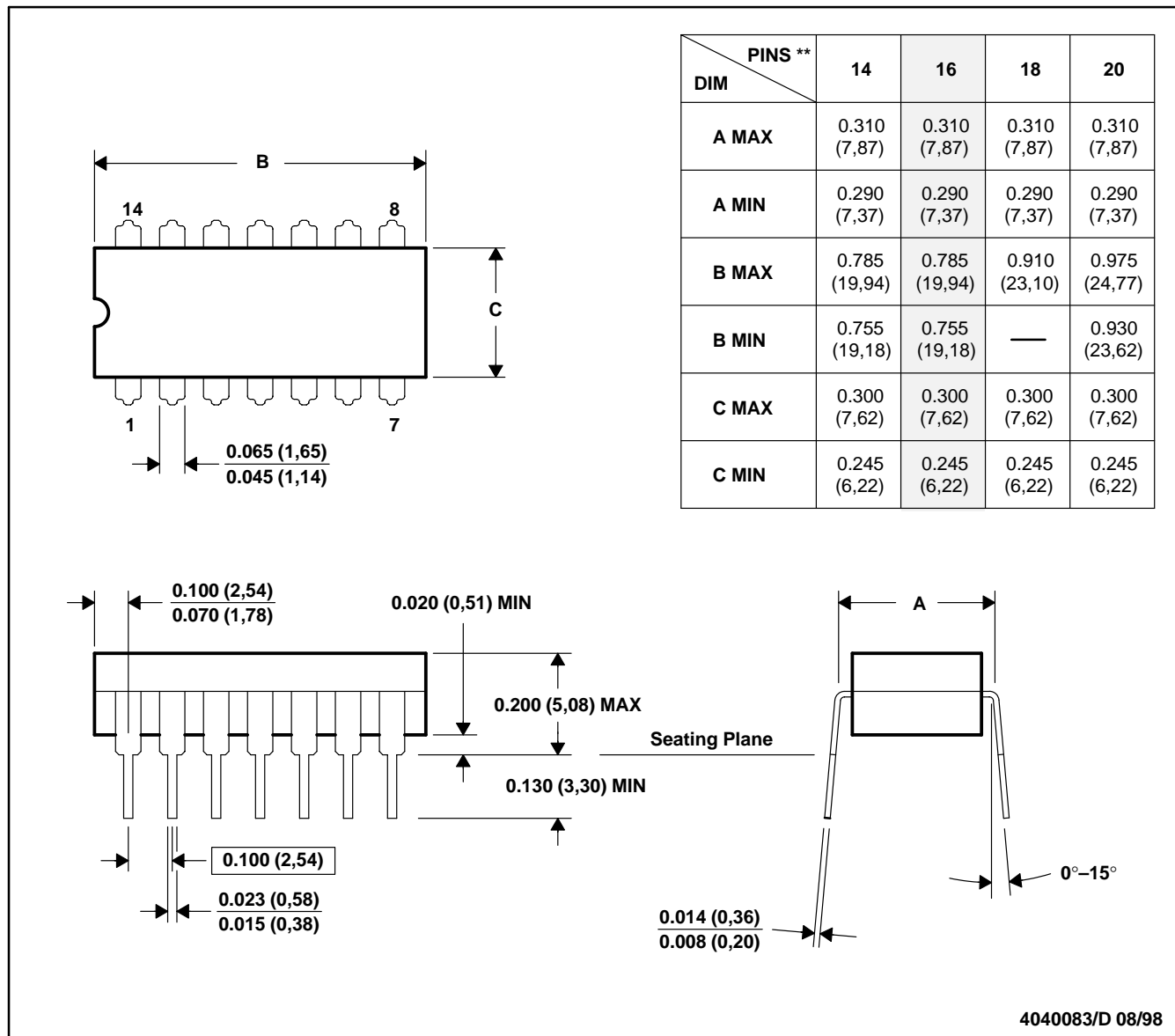

- NOTES: A. All linear dimensions are in inches (millimeters).
 B. This drawing is subject to change without notice.
 C. This package can be hermetically sealed with a ceramic lid using glass frit.
 D. Index point is provided on cap for terminal identification only on press ceramic glass frit seal.
 E. Falls within MIL STD 1835 GDIP1-T14, GDIP1-T16, GDIP1-T18, GDIP1-T20, and GDIP1-T22.



SN55LVDS31, SN65LVDS31, SN65LVDS3487, SN65LVDS9638 HIGH-SPEED DIFFERENTIAL LINE DRIVERS

SLLS261J – JULY 1997 – REVISED OCTOBER 2002

MECHANICAL INFORMATION

PW (R-PDSO-G**)

PLASTIC SMALL-OUTLINE PACKAGE

14 PINS SHOWN

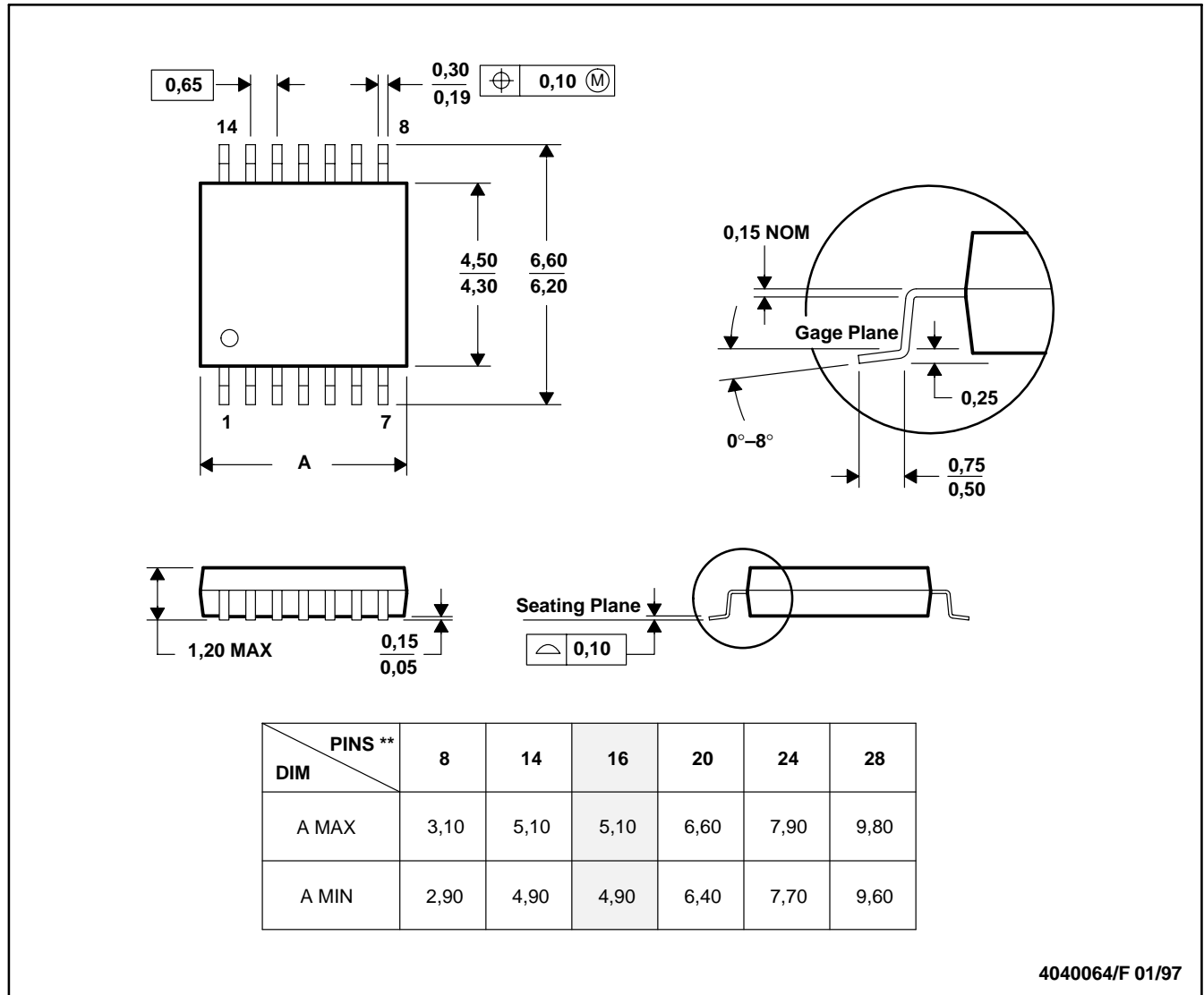

- NOTES: A. All linear dimensions are in millimeters.
 B. This drawing is subject to change without notice.
 C. Body dimensions do not include mold flash or protrusion not to exceed 0,15.
 D. Falls within JEDEC MO-153

SN55LVDS31, SN65LVDS31, SN65LVDS3487, SN65LVDS9638 HIGH-SPEED DIFFERENTIAL LINE DRIVERS

SLLS261J – JULY 1997 – REVISED OCTOBER 2002

MECHANICAL INFORMATION

W (R-GDFP-F16)

CERAMIC DUAL FLATPACK

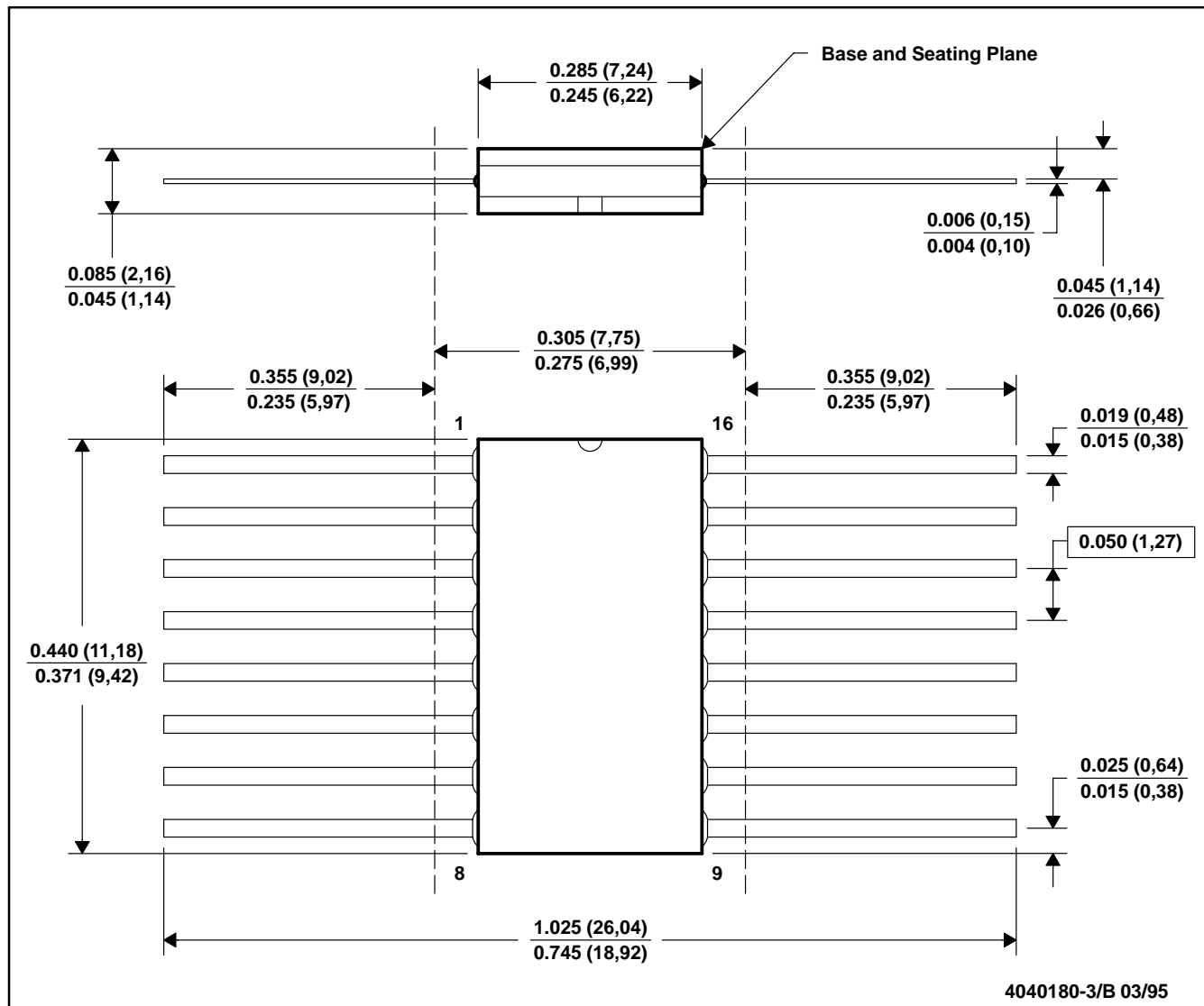

- NOTES: A. All linear dimensions are in inches (millimeters).
 B. This drawing is subject to change without notice.
 C. This package can be hermetically sealed with a ceramic lid using glass frit.
 D. Index point is provided on cap for terminal identification only.
 E. Falls within MIL-STD-1835 GDFP1-F16 and JEDEC MO-092AC

IMPORTANT NOTICE

Texas Instruments Incorporated and its subsidiaries (TI) reserve the right to make corrections, modifications, enhancements, improvements, and other changes to its products and services at any time and to discontinue any product or service without notice. Customers should obtain the latest relevant information before placing orders and should verify that such information is current and complete. All products are sold subject to TI's terms and conditions of sale supplied at the time of order acknowledgment.

TI warrants performance of its hardware products to the specifications applicable at the time of sale in accordance with TI's standard warranty. Testing and other quality control techniques are used to the extent TI deems necessary to support this warranty. Except where mandated by government requirements, testing of all parameters of each product is not necessarily performed.

TI assumes no liability for applications assistance or customer product design. Customers are responsible for their products and applications using TI components. To minimize the risks associated with customer products and applications, customers should provide adequate design and operating safeguards.

TI does not warrant or represent that any license, either express or implied, is granted under any TI patent right, copyright, mask work right, or other TI intellectual property right relating to any combination, machine, or process in which TI products or services are used. Information published by TI regarding third-party products or services does not constitute a license from TI to use such products or services or a warranty or endorsement thereof. Use of such information may require a license from a third party under the patents or other intellectual property of the third party, or a license from TI under the patents or other intellectual property of TI.

Reproduction of information in TI data books or data sheets is permissible only if reproduction is without alteration and is accompanied by all associated warranties, conditions, limitations, and notices. Reproduction of this information with alteration is an unfair and deceptive business practice. TI is not responsible or liable for such altered documentation.

Resale of TI products or services with statements different from or beyond the parameters stated by TI for that product or service voids all express and any implied warranties for the associated TI product or service and is an unfair and deceptive business practice. TI is not responsible or liable for any such statements.

Mailing Address:

Texas Instruments
Post Office Box 655303
Dallas, Texas 75265