

TYPES SN54178, SN54179, SN74178, SN74179 4-BIT PARALLEL-ACCESS SHIFT REGISTERS

DECEMBER 1972—REVISED DECEMBER 1983

- Typical Maximum Clock Frequency . . . 39 MHz
- Three Operating Modes:
Synchronous Parallel Load
Right Shift
Hold (Do Nothing)
- Negative-Edge-Triggered Clocking
- D-C Coupling Simplifies System Designs

description

These shift registers utilize fully d-c coupled storage elements and feature synchronous parallel inputs and parallel outputs. The SN54179/SN74179 has a direct clear line and complementary output from the D flip-flop, thereby differing from the SN54178/SN74178.

Parallel loading is accomplished by taking the shift input low, applying the four bits of data, and taking the load input high. The data is loaded into the associated flip-flop synchronously and appears at the outputs after a high-to-low transition of the clock. During loading, serial data flow is inhibited.

Shift right is also accomplished on the falling edge of the clock pulse when the shift input is high regardless of the level of the load input. Serial data for this mode is entered at the serial data input.

When both the shift and load inputs are low, clocking of the register can continue; however, data appearing at each output is fed back to the flip-flop input creating a mode in which the data is held unchanged. Thus, the system clock may be left free-running without changing the contents of the register.

SN54178 . . . J OR W PACKAGE
SN74178 . . . J OR N PACKAGE
(TOP VIEW)

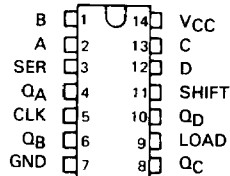

SN54179 . . . J OR W PACKAGE
SN74179 . . . J OR N PACKAGE
(TOP VIEW)

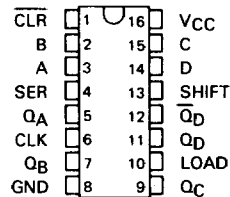

'178, '179†
FUNCTION TABLE

INPUTS					OUTPUTS								
CLEAR†	SHIFT	LOAD	CLOCK	SERIAL	PARALLEL				QA	QB	QC	QD	QD†
					A	B	C	D					
L	X	X	X	X	X	X	X	X	L	L	L	L	H
H	X	X	H	X	X	X	X	X	QA0	QB0	QC0	QD0	QD0
H	L	L	↓	X	X	X	X	X	QA0	QB0	QC0	QD0	QD0
H	L	H	↓	X	a	b	c	d	a	b	c	d	d
H	H	X	↓	H	X	X	X	X	H	QA _n	QB _n	QC _n	QC _n
H	H	X	↓	L	X	X	X	X	L	QA _n	QB _n	QC _n	QC _n

† The columns for clear, Q_D, and the top line of the table apply for the '179 only.

H = high level (steady state), L = low level (steady state)

X = irrelevant (any input, including transitions)

↓ = transition from high to low level

a, b, c, d = the level of steady-state input at inputs A, B, C, or D, respectively.

QA0, QB0, QC0, QD0 = the level of QA, QB, QC, or QD, respectively, before the indicated steady-state input conditions were established.

QA_n, QB_n, QC_n = the level of QA, QB, or QC, respectively, before the most-recent ↓ transition of the clock.

PRODUCTION DATA

This document contains information current as of publication date. Products conform to specifications per the terms of Texas Instruments standard warranty. Production processing does not necessarily include testing of all parameters.

TEXAS
INSTRUMENTS

POST OFFICE BOX 225012 • DALLAS, TEXAS 75265

3

TTL DEVICES

3-701

TYPES SN54178, SN54179, SN74178, SN74179
4-BIT PARALLEL-ACCESS SHIFT REGISTERS

logic diagram

(^{'178}) (^{'179})

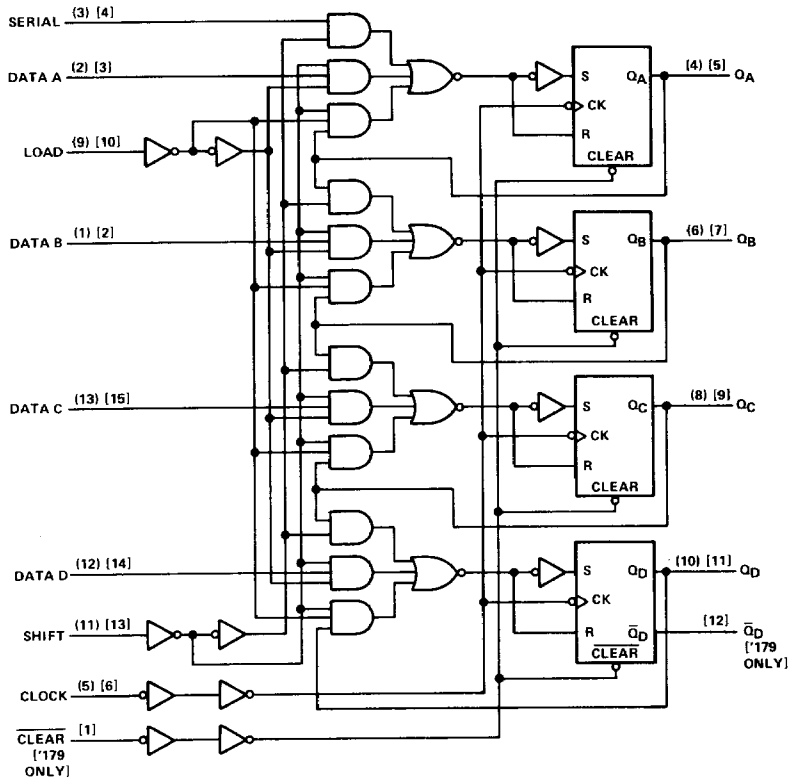

Pin numbers shown on logic notation are for J or N packages.

3

TTL DEVICES

schematics of inputs and outputs

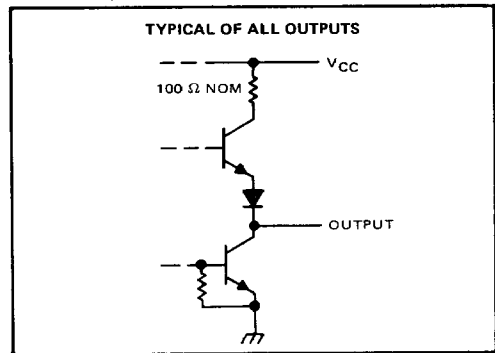
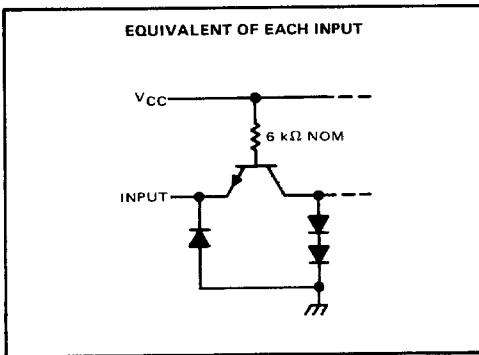

TYPES SN54178, SN54179, SN74178, SN74179 4-BIT PARALLEL-ACCESS SHIFT REGISTERS

absolute maximum ratings over operating free-air temperature range (unless otherwise noted)

Supply voltage, V_{CC} (see Note 1)	7 V
Input voltage	5.5 V
Operating free-air temperature range: SN54178, SN54179 Circuits	-55°C to 125°C
SN74178, SN74179 Circuits	0°C to 70°C
Storage temperature range	-65°C to 150°C

NOTE 1: Voltage values are with respect to network ground terminal.

recommended operating conditions

	SN54178, SN54179			SN74178, SN74179			UNIT
	MIN	NOM	MAX	MIN	NOM	MAX	
Supply voltage, V_{CC}	4.5	5	5.5	4.75	5	5.25	V
High-level output current, I_{OH}			-800			-800	μ A
Low-level output current, I_{OL}			16			16	mA
Clock frequency, f_{clock}	0	25		0	25		MHz
Width of clock or clear pulse, t_W (see Figure 1)	20			20			ns
Setup time, t_{SU} (see Figure 1)	Shift (H or L) or load			35			ns
	Data			30			
	Clear-inactive-state (SN54179 and SN74179)			15			
Hold time at any input, t_H	5			5			ns
Operating free-air temperature, T_A	-55	125		0	70		°C

3

electrical characteristics over recommended operating free-air temperature range (unless otherwise noted)

PARAMETER	TEST CONDITIONS†	SN54178, SN54179			SN74178, SN74179			UNIT
		MIN	TYP‡	MAX	MIN	TYP‡	MAX	
V_{IH} High-level input voltage		2			2			V
V_{IL} Low-level input voltage				0.8			0.8	V
V_{IK} Input clamp voltage	$V_{CC} = \text{MIN}, I_I = -12 \text{ mA}$			-1.5			-1.5	V
V_{OH} High-level output voltage	$V_{CC} = \text{MIN}, V_{IH} = 2 \text{ V}, V_{IL} = 0.8 \text{ V}, I_{OH} = -800 \mu\text{A}$	2.4	3.4		2.4	3.4		V
V_{OL} Low-level output voltage	$V_{CC} = \text{MIN}, V_{IH} = 2 \text{ V}, V_{IL} = 0.8 \text{ V}, I_{OL} = 16 \text{ mA}$		0.2	0.4		0.2	0.4	V
I_I Input current at maximum input voltage	$V_{CC} = \text{MAX}, V_I = 5.5 \text{ V}$			1			1	mA
I_{IH} High-level input current	$V_{CC} = \text{MAX}, V_I = 2.4 \text{ V}$			40			40	μ A
I_{IL} Low-level input current	$V_{CC} = \text{MAX}, V_I = 0.4 \text{ V}$			-1.6			-1.6	mA
I_{OS} Short-circuit output current§	$V_{CC} = \text{MAX}$	-20		-57	-18		-57	mA
I_{CC} Supply current	$V_{CC} = \text{MAX}, \text{ See Note 2}$		46	70		46	75	mA

† For conditions shown as MIN or MAX, use the appropriate value specified under recommended operating conditions for the applicable device type.

‡ All typical values are at $V_{CC} = 5 \text{ V}, T_A = 25^\circ\text{C}$.

§ Not more than one output should be shorted at a time.

NOTE 2: I_{CC} is measured as follows:

- 4.5 V is applied to serial inputs, load, shift, and clear.
- Parallel inputs A through D are grounded.
- 4.5 V is momentarily applied to clock which is then grounded.

TTL DEVICES

TYPES SN54178, SN54179, SN74178, SN74179 4-BIT PARALLEL-ACCESS SHIFT REGISTERS

switching characteristics, $V_{CC} = 5\text{ V}$, $T_A = 25^\circ\text{C}$

PARAMETER [†]	FROM (INPUT)	TO (OUTPUT)	TEST CONDITIONS	MIN	TYP	MAX	UNIT
f_{max}			$C_L = 15\text{ pF}$, $R_L = 400\ \Omega$, See Figure 1	25	39		MHz
t_{PLH}	Clear	\bar{Q}_D		15	23		ns
t_{PHL}		Q_A, Q_B, Q_C, Q_D		24	36		ns
t_{PLH}	Clock	Any output		17	26		ns
t_{PHL}				23	35		ns

[†] f_{max} ≡ Maximum clock frequency

t_{PHL} ≡ Propagation delay time, high-to-low-level output

t_{PLH} ≡ Propagation delay time, low-to-high-level output

PARAMETER MEASUREMENT INFORMATION

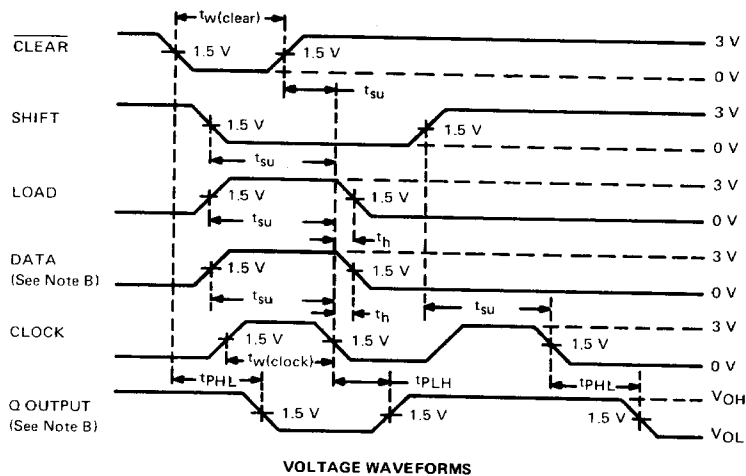
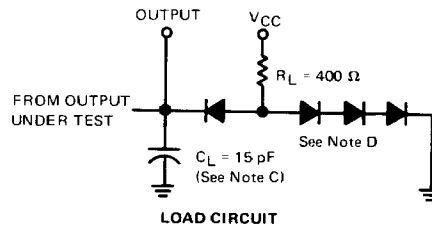

- NOTES: A. Input pulses are supplied by generators having the following characteristics: $t_{\text{TLH}} \leq 10\text{ ns}$, $t_{\text{THL}} \leq 10\text{ ns}$, $\text{PRR} \leq 1\text{ MHz}$, $Z_{\text{out}} \approx 50\ \Omega$.
- B. Data input and Q output are any related pair. Serial and other data inputs are at GND. Serial data input is tested in conjunction with Q_A output in the shift mode.
- C. C_L includes probe and jig capacitance.
- D. All diodes are 1N3064 or equivalent.

FIGURE 1—SWITCHING TIMES