

- Member of the Texas Instruments Widebus™ Family
- DOC™ (Dynamic Output Control) Circuit Dynamically Changes Output Impedance, Resulting in Noise Reduction Without Speed Degradation
- Less Than 2-ns Maximum Propagation Delay at 2.5-V and 3.3-V V_{CC}
- Dynamic Drive Capability Is Equivalent to Standard Outputs With I_{OH} and I_{OL} of ±24 mA at 2.5-V V_{CC}
- Overvoltage-Tolerant Inputs/Outputs Allow Mixed-Voltage-Mode Data Communications
- I_{off} Supports Partial-Power-Down Mode Operation
- Latch-Up Performance Exceeds 100 mA Per JESD 78, Class II
- ESD Protection Exceeds JESD 22
 - 2000-V Human-Body Model (A114-A)
 - 200-V Machine Model (A115-A)

description/ordering information

A Dynamic Output Control (DOC) circuit is implemented, which, during the transition, initially lowers the output impedance to effectively drive the load and, subsequently, raises the impedance to reduce noise. Figure 1 shows typical V_{OL} vs I_{OL} and V_{OH} vs I_{OH} curves to illustrate the output impedance and drive capability of the circuit. At the beginning of the signal transition, the DOC circuit provides a maximum dynamic drive that is equivalent to a high-drive standard-output device. For more information, refer to the TI application reports, *AVC Logic Family Technology and Applications*, literature number SCEA006, and *Dynamic Output Control (DOC™) Circuitry Technology and Applications*, literature number SCEA009.

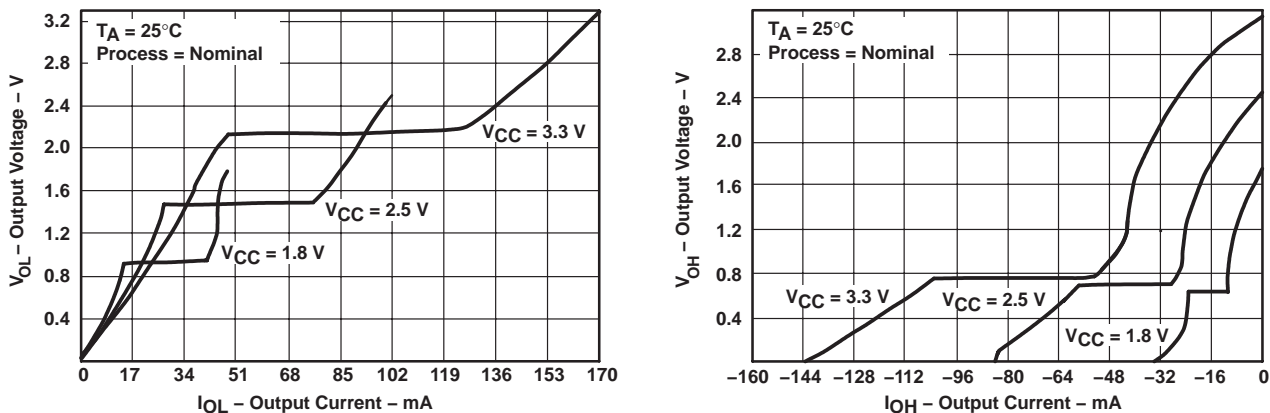

Figure 1. Output Voltage vs Output Current

ORDERING INFORMATION

T _A	PACKAGE†		ORDERABLE PART NUMBER	TOP-SIDE MARKING
-40°C to 85°C	TSSOP – DGG	Tape and reel	SN74AVC16244DGGR	AVC16244
	TVSOP – DGV	Tape and reel	SN74AVC16244DGVR	CVA244
	VFBGA – GQL	Tape and reel	SN74AVC16244GQLR	CVA244
	VFBGA – ZQL (Pb-free)		SN74AVC16244ZQLR	

† Package drawings, standard packing quantities, thermal data, symbolization, and PCB design guidelines are available at www.ti.com/sc/package.



Please be aware that an important notice concerning availability, standard warranty, and use in critical applications of Texas Instruments semiconductor products and disclaimers thereto appears at the end of this data sheet.

DOC and Widebus are trademarks of Texas Instruments.

PRODUCTION DATA information is current as of publication date. Products conform to specifications per the terms of Texas Instruments standard warranty. Production processing does not necessarily include testing of all parameters.



SN74AVC16244

16-BIT BUFFER/DRIVER

WITH 3-STATE OUTPUTS

SCES141N – JULY 1998 – REVISED JULY 2004

description/ordering information (continued)

This 16-bit buffer/driver is operational at 1.2-V to 3.6-V V_{CC} , but is designed specifically for 1.65-V to 3.6-V V_{CC} operation.

The SN74AVC16244 is designed specifically to improve the performance and density of 3-state memory address drivers, clock drivers, and bus-oriented receivers and transmitters.

The device can be used as four 4-bit buffers, two 8-bit buffers, or one 16-bit buffer. It provides true outputs and symmetrical active-low output-enable (\overline{OE}) inputs.

This device is fully specified for partial-power-down applications using I_{off} . The I_{off} circuitry disables the outputs, preventing damaging current backflow through the device when it is powered down.

To ensure the high-impedance state during power up or power down, \overline{OE} should be tied to V_{CC} through a pullup resistor; the minimum value of the resistor is determined by the current-sinking capability of the driver.

terminal assignments

DGG OR DGV PACKAGE
(TOP VIEW)

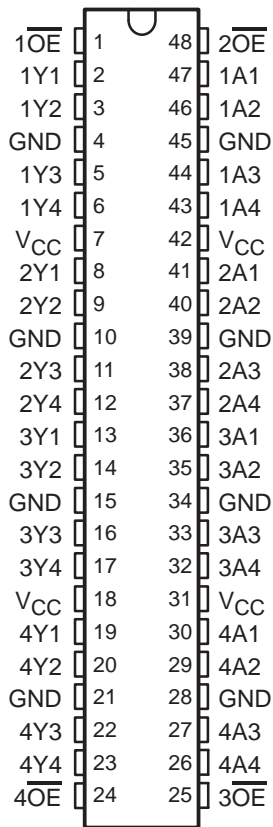

**GQL OR ZQL PACKAGE
 (TOP VIEW)**

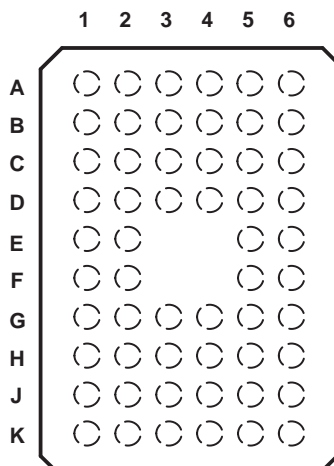

terminal assignments

	1	2	3	4	5	6
A	$\overline{1OE}$	NC	NC	NC	NC	$\overline{2OE}$
B	1Y2	1Y1	GND	GND	1A1	1A2
C	1Y4	1Y3	V _{CC}	V _{CC}	1A3	1A4
D	2Y2	2Y1	GND	GND	2A1	2A2
E	2Y4	2Y3			2A3	2A4
F	3Y1	3Y2			3A2	3A1
G	3Y3	3Y4	GND	GND	3A4	3A3
H	4Y1	4Y2	V _{CC}	V _{CC}	4A2	4A1
J	4Y3	4Y4	GND	GND	4A4	4A3
K	$\overline{4OE}$	NC	NC	NC	NC	$\overline{3OE}$

NC – No internal connection

**FUNCTION TABLE
 (each 4-bit buffer)**

INPUTS		OUTPUT
\overline{OE}	A	Y
L	L	L
L	H	H
H	X	Z

SN74AVC16244
16-BIT BUFFER/DRIVER
WITH 3-STATE OUTPUTS

SCES141N – JULY 1998 – REVISED JULY 2004

recommended operating conditions (see Note 4)

		MIN	MAX	UNIT	
V _{CC}	Supply voltage	Operating	1.4	3.6	V
		Data retention only	1.2		
V _{IH}	High-level input voltage	V _{CC} = 1.2 V	V _{CC}		V
		V _{CC} = 1.4 V to 1.6 V	0.65 × V _{CC}		
		V _{CC} = 1.65 V to 1.95 V	0.65 × V _{CC}		
		V _{CC} = 2.3 V to 2.7 V	1.7		
		V _{CC} = 3 V to 3.6 V	2		
V _{IL}	Low-level input voltage	V _{CC} = 1.2 V	GND		V
		V _{CC} = 1.4 V to 1.6 V	0.35 × V _{CC}		
		V _{CC} = 1.65 V to 1.95 V	0.35 × V _{CC}		
		V _{CC} = 2.3 V to 2.7 V	0.7		
		V _{CC} = 3 V to 3.6 V	0.8		
V _I	Input voltage	0	3.6	V	
V _O	Output voltage	Active state	0	V _{CC}	V
		3-state	0	3.6	
I _{OHS}	Static high-level output current†	V _{CC} = 1.4 V to 1.6 V	–2		mA
		V _{CC} = 1.65 V to 1.95 V	–4		
		V _{CC} = 2.3 V to 2.7 V	–8		
		V _{CC} = 3 V to 3.6 V	–12		
I _{OLS}	Static low-level output current†	V _{CC} = 1.4 V to 1.6 V	2		mA
		V _{CC} = 1.65 V to 1.95 V	4		
		V _{CC} = 2.3 V to 2.7 V	8		
		V _{CC} = 3 V to 3.6 V	12		
Δt/Δv	Input transition rise or fall rate	V _{CC} = 1.4 V to 3.6 V		5	ns/V
T _A	Operating free-air temperature	–40	85	°C	

† Dynamic drive capability is equivalent to standard outputs with I_{OH} and I_{OL} of ±24 mA at 2.5-V V_{CC}. See Figure 1 for V_{OL} vs I_{OL} and V_{OH} vs I_{OH} characteristics. Refer to the TI application reports, **AVC Logic Family Technology and Applications**, literature number **SCEA006**, and **Dynamic Output Control (DOC™) Circuitry Technology and Applications**, literature number **SCEA009**.

NOTE 4: All unused inputs of the device must be held at V_{CC} or GND to ensure proper device operation. Refer to the TI application report, *Implications of Slow or Floating CMOS Inputs*, literature number SCBA004.



SN74AVC16244

16-BIT BUFFER/DRIVER WITH 3-STATE OUTPUTS

SCES141N – JULY 1998 – REVISED JULY 2004

electrical characteristics over recommended operating free-air temperature range (unless otherwise noted)

PARAMETER		TEST CONDITIONS	V _{CC}	MIN	TYP†	MAX	UNIT
V _{OH}		I _{OHS} = -100 μA	1.4 V to 3.6 V	V _{CC} - 0.2			V
		I _{OHS} = -2 mA, V _{IH} = 0.91 V	1.4 V	1.05			
		I _{OHS} = -4 mA, V _{IH} = 1.07 V	1.65 V	1.2			
		I _{OHS} = -8 mA, V _{IH} = 1.7 V	2.3 V	1.75			
		I _{OHS} = -12 mA, V _{IH} = 2 V	3 V	2.3			
V _{OL}		I _{OLS} = 100 μA	1.4 V to 3.6 V			0.2	V
		I _{OLS} = 2 mA, V _{IL} = 0.49 V	1.4 V			0.4	
		I _{OLS} = 4 mA, V _{IL} = 0.57 V	1.65 V			0.45	
		I _{OLS} = 8 mA, V _{IL} = 0.7 V	2.3 V			0.55	
		I _{OLS} = 12 mA, V _{IL} = 0.8 V	3 V			0.7	
I _I		V _I = V _{CC} or GND	3.6 V			±2.5	μA
I _{off}		V _I or V _O = 3.6 V	0			±10	μA
I _{OZ}		V _O = V _{CC} or GND	3.6 V			±10	μA
I _{CC}		V _I = V _{CC} or GND, I _O = 0	3.6 V			40	μA
C _i	Control inputs	V _I = V _{CC} or GND	2.5 V	3.5			pF
			3.3 V	3.5			
	Data inputs	V _I = V _{CC} or GND	2.5 V	6			
			3.3 V	6			
C _o	Outputs	V _O = V _{CC} or GND	2.5 V	6.5			pF
			3.3 V	6.5			

† Typical values are measured at T_A = 25°C.

switching characteristics over recommended operating free-air temperature range (unless otherwise noted) (see Figure 2)

PARAMETER	FROM (INPUT)	TO (OUTPUT)	V _{CC} = 1.2 V	V _{CC} = 1.5 V ± 0.1 V		V _{CC} = 1.8 V ± 0.15 V		V _{CC} = 2.5 V ± 0.2 V		V _{CC} = 3.3 V ± 0.3 V		UNIT
			TYP	MIN	MAX	MIN	MAX	MIN	MAX	MIN	MAX	
t _{pd}	A	Y	3.1	0.6	3.3	0.7	2.9	0.6	1.9	0.5	1.7	ns
t _{en}	\overline{OE}	Y	7.6	1.4	8	1.3	6.8	0.9	4	0.7	3.5	ns
t _{dis}	\overline{OE}	Y	7.2	1.7	7.3	1.6	6.2	1	4.3	1	3.5	ns

operating characteristics, T_A = 25°C

PARAMETER		TEST CONDITIONS	V _{CC} = 1.8 V	V _{CC} = 2.5 V	V _{CC} = 3.3 V	UNIT	
			TYP	TYP	TYP		
C _{pd}	Power dissipation capacitance	Outputs enabled	C _L = 0, f = 10 MHz	23	27	33	pF
		Outputs disabled		0.1	0.1	0.1	



PARAMETER MEASUREMENT INFORMATION

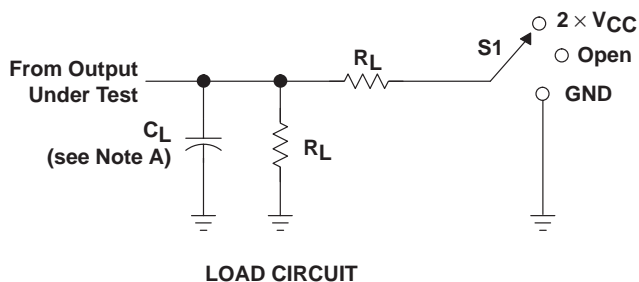

TEST	S1
t_{PLH}/t_{PHL}	Open
t_{PLZ}/t_{PZL}	$2 \times V_{CC}$
t_{PHZ}/t_{PZH}	GND

V_{CC}	C_L	R_L	V_{Δ}
1.2 V	15 pF	2 k Ω	0.1 V
1.5 V \pm 0.1 V	15 pF	2 k Ω	0.1 V
1.8 V \pm 0.15 V	30 pF	1 k Ω	0.15 V
2.5 V \pm 0.2 V	30 pF	500 Ω	0.15 V
3.3 V \pm 0.3 V	30 pF	500 Ω	0.3 V

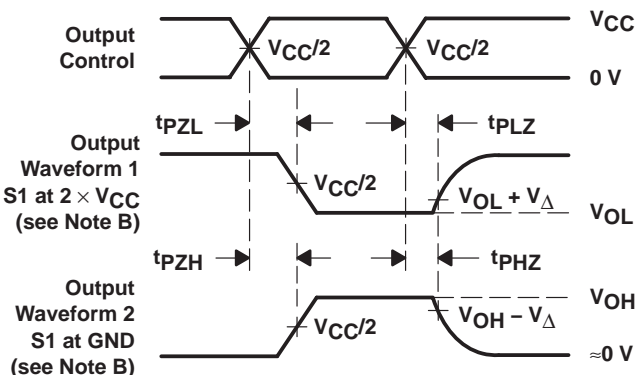
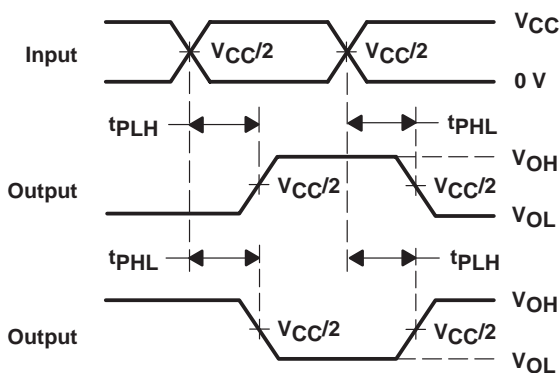
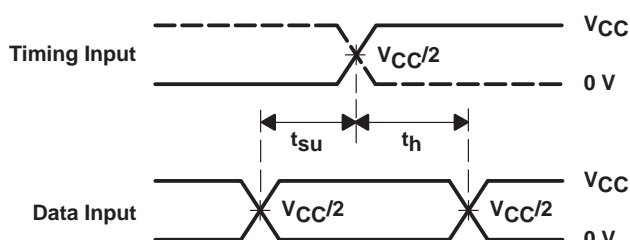
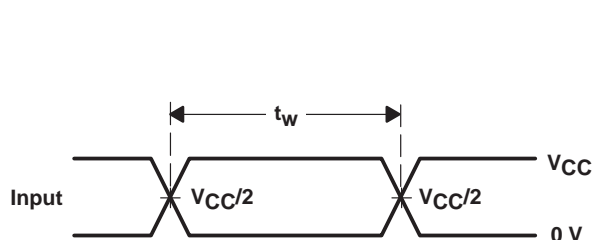

- NOTES:
- C_L includes probe and jig capacitance.
 - Waveform 1 is for an output with internal conditions such that the output is low, except when disabled by the output control. Waveform 2 is for an output with internal conditions such that the output is high, except when disabled by the output control.
 - All input pulses are supplied by generators having the following characteristics: PRR \leq 10 MHz, $Z_O = 50 \Omega$, slew rate \geq 1 V/ns.
 - The outputs are measured one at a time, with one transition per measurement.
 - t_{PLZ} and t_{PHZ} are the same as t_{dis} .
 - t_{PZL} and t_{PZH} are the same as t_{en} .
 - t_{PLH} and t_{PHL} are the same as t_{pd} .
 - All parameters and waveforms are not applicable to all devices.

Figure 2. Load Circuit and Voltage Waveforms

PACKAGING INFORMATION

Orderable Device	Status ⁽¹⁾	Package Type	Package Drawing	Pins	Package Qty	Eco Plan ⁽²⁾	Lead/Ball Finish	MSL Peak Temp ⁽³⁾
SN74AVC16244DGGR	ACTIVE	TSSOP	DGG	48	2000	Pb-Free (RoHS)	CU NIPDAU	Level-1-250C-UNLIM
SN74AVC16244DGVR	ACTIVE	TVSOP	DGV	48	2000	Pb-Free (RoHS)	CU NIPDAU	Level-1-250C-UNLIM
SN74AVC16244GQLR	ACTIVE	VFBGA	GQL	56	1000	None	SNPB	Level-1-240C-UNLIM

⁽¹⁾ The marketing status values are defined as follows:

ACTIVE: Product device recommended for new designs.

LIFEBUY: TI has announced that the device will be discontinued, and a lifetime-buy period is in effect.

NRND: Not recommended for new designs. Device is in production to support existing customers, but TI does not recommend using this part in a new design.

PREVIEW: Device has been announced but is not in production. Samples may or may not be available.

OBSOLETE: TI has discontinued the production of the device.

⁽²⁾ Eco Plan - May not be currently available - please check <http://www.ti.com/productcontent> for the latest availability information and additional product content details.

None: Not yet available Lead (Pb-Free).

Pb-Free (RoHS): TI's terms "Lead-Free" or "Pb-Free" mean semiconductor products that are compatible with the current RoHS requirements for all 6 substances, including the requirement that lead not exceed 0.1% by weight in homogeneous materials. Where designed to be soldered at high temperatures, TI Pb-Free products are suitable for use in specified lead-free processes.

Green (RoHS & no Sb/Br): TI defines "Green" to mean "Pb-Free" and in addition, uses package materials that do not contain halogens, including bromine (Br) or antimony (Sb) above 0.1% of total product weight.

⁽³⁾ MSL, Peak Temp. -- The Moisture Sensitivity Level rating according to the JEDEC industry standard classifications, and peak solder temperature.

Important Information and Disclaimer: The information provided on this page represents TI's knowledge and belief as of the date that it is provided. TI bases its knowledge and belief on information provided by third parties, and makes no representation or warranty as to the accuracy of such information. Efforts are underway to better integrate information from third parties. TI has taken and continues to take reasonable steps to provide representative and accurate information but may not have conducted destructive testing or chemical analysis on incoming materials and chemicals. TI and TI suppliers consider certain information to be proprietary, and thus CAS numbers and other limited information may not be available for release.

In no event shall TI's liability arising out of such information exceed the total purchase price of the TI part(s) at issue in this document sold by TI to Customer on an annual basis.

DGV (R-PDSO-G**)

PLASTIC SMALL-OUTLINE

24 PINS SHOWN



- NOTES: A. All linear dimensions are in millimeters.
 B. This drawing is subject to change without notice.
 C. Body dimensions do not include mold flash or protrusion, not to exceed 0,15 per side.
 D. Falls within JEDEC: 24/48 Pins – MO-153
 14/16/20/56 Pins – MO-194

GQL (R-PBGA-N56)

PLASTIC BALL GRID ARRAY

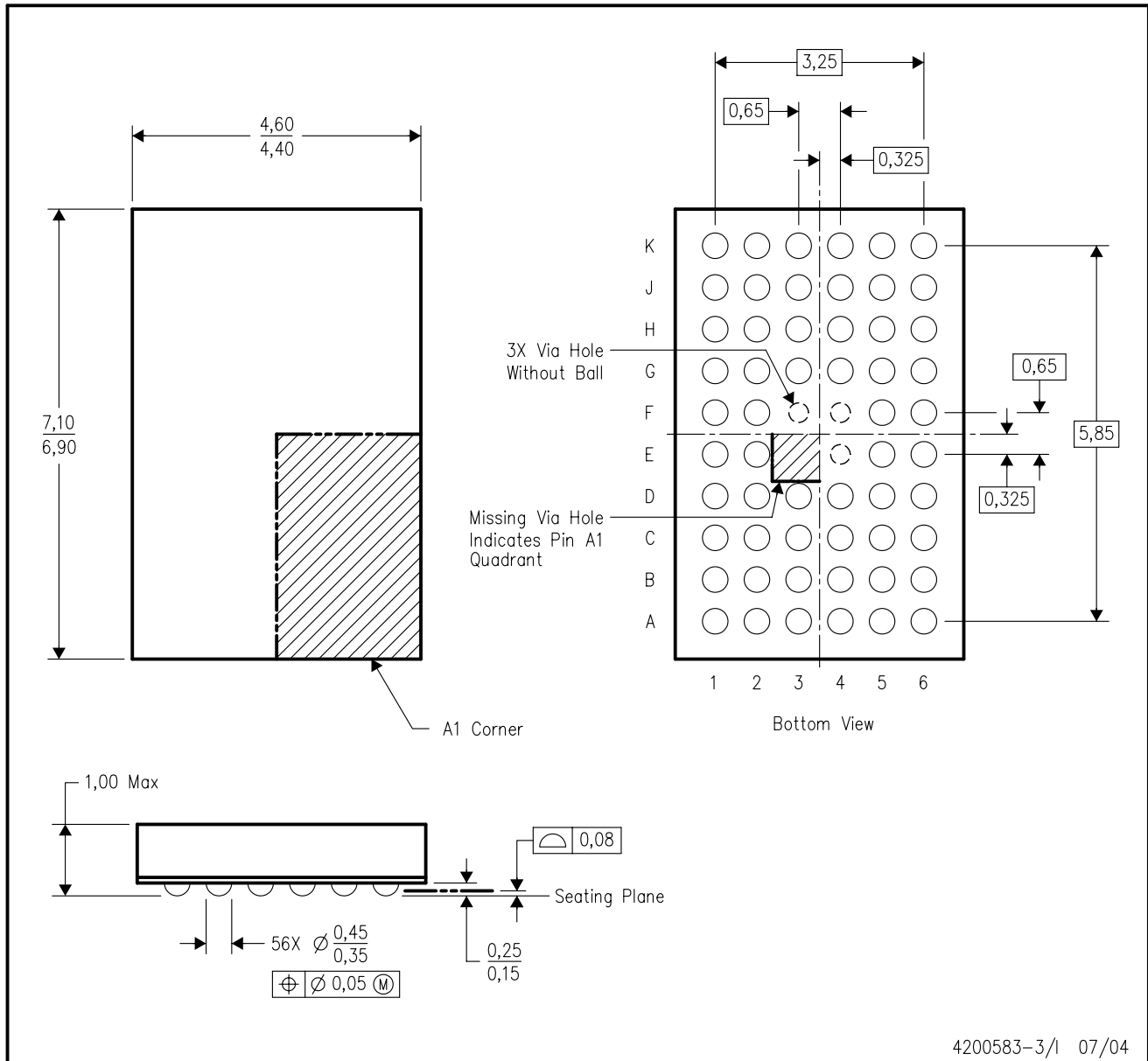

- NOTES:
- A. All linear dimensions are in millimeters.
 - B. This drawing is subject to change without notice.
 - C. Falls within JEDEC MO-225 variation BA.
 - D. This package is tin-lead (SnPb). Refer to the 56 ZQL package (drawing 4204437) for lead-free.

DGG (R-PDSO-G**)

PLASTIC SMALL-OUTLINE PACKAGE

48 PINS SHOWN



- NOTES: A. All linear dimensions are in millimeters.
 B. This drawing is subject to change without notice.
 C. Body dimensions do not include mold protrusion not to exceed 0,15.
 D. Falls within JEDEC MO-153

IMPORTANT NOTICE

Texas Instruments Incorporated and its subsidiaries (TI) reserve the right to make corrections, modifications, enhancements, improvements, and other changes to its products and services at any time and to discontinue any product or service without notice. Customers should obtain the latest relevant information before placing orders and should verify that such information is current and complete. All products are sold subject to TI's terms and conditions of sale supplied at the time of order acknowledgment.

TI warrants performance of its hardware products to the specifications applicable at the time of sale in accordance with TI's standard warranty. Testing and other quality control techniques are used to the extent TI deems necessary to support this warranty. Except where mandated by government requirements, testing of all parameters of each product is not necessarily performed.

TI assumes no liability for applications assistance or customer product design. Customers are responsible for their products and applications using TI components. To minimize the risks associated with customer products and applications, customers should provide adequate design and operating safeguards.

TI does not warrant or represent that any license, either express or implied, is granted under any TI patent right, copyright, mask work right, or other TI intellectual property right relating to any combination, machine, or process in which TI products or services are used. Information published by TI regarding third-party products or services does not constitute a license from TI to use such products or services or a warranty or endorsement thereof. Use of such information may require a license from a third party under the patents or other intellectual property of the third party, or a license from TI under the patents or other intellectual property of TI.

Reproduction of information in TI data books or data sheets is permissible only if reproduction is without alteration and is accompanied by all associated warranties, conditions, limitations, and notices. Reproduction of this information with alteration is an unfair and deceptive business practice. TI is not responsible or liable for such altered documentation.

Resale of TI products or services with statements different from or beyond the parameters stated by TI for that product or service voids all express and any implied warranties for the associated TI product or service and is an unfair and deceptive business practice. TI is not responsible or liable for any such statements.

Following are URLs where you can obtain information on other Texas Instruments products and application solutions:

Products		Applications	
Amplifiers	amplifier.ti.com	Audio	www.ti.com/audio
Data Converters	dataconverter.ti.com	Automotive	www.ti.com/automotive
DSP	dsp.ti.com	Broadband	www.ti.com/broadband
Interface	interface.ti.com	Digital Control	www.ti.com/digitalcontrol
Logic	logic.ti.com	Military	www.ti.com/military
Power Mgmt	power.ti.com	Optical Networking	www.ti.com/opticalnetwork
Microcontrollers	microcontroller.ti.com	Security	www.ti.com/security
		Telephony	www.ti.com/telephony
		Video & Imaging	www.ti.com/video
		Wireless	www.ti.com/wireless

Mailing Address: Texas Instruments
Post Office Box 655303 Dallas, Texas 75265