

- Member of the Texas Instruments *Widebus™* Family
- *EPIC™* (Enhanced-Performance Implanted CMOS) Submicron Process
- *DOC™* (Dynamic Output Control) Circuit Dynamically Changes Output Impedance, Resulting in Noise Reduction Without Speed Degradation
- Dynamic Drive Capability Is Equivalent to Standard Outputs With I_{OH} and I_{OL} of ± 24 mA at 2.5-V V_{CC}
- Overvoltage-Tolerant Inputs/Outputs Allow Mixed-Voltage-Mode Data Communications
- I_{Off} Supports Partial-Power-Down Mode Operation
- Ideal for Use in PC133 Registered DIMM Applications
- ESD Protection Exceeds JESD 22
 - 2000-V Human-Body Model (A114-A)
 - 200-V Machine Model (A115-A)
- Latch-Up Performance Exceeds 100 mA Per JESD 78, Class II
- Package Options Include Plastic Thin Shrink Small-Outline (DGG) and Thin Very Small-Outline (DGV) Packages

description

A Dynamic Output Control (DOC) circuit is implemented, which, during the transition, initially lowers the output impedance to effectively drive the load and, subsequently, raises the impedance to reduce noise. Figure 1 shows typical V_{OL} vs I_{OL} and V_{OH} vs I_{OH} curves to illustrate the output impedance and drive capability of the circuit. At the beginning of the signal transition, the DOC circuit provides a maximum dynamic drive that is equivalent to a high-drive standard-output device. For more information, refer to TI application reports *AVC Logic Family Technology and Applications*, literature number SCEA006, and *Dynamic Output Control (DOC™) Circuitry Technology and Applications*, literature number SCEA009.

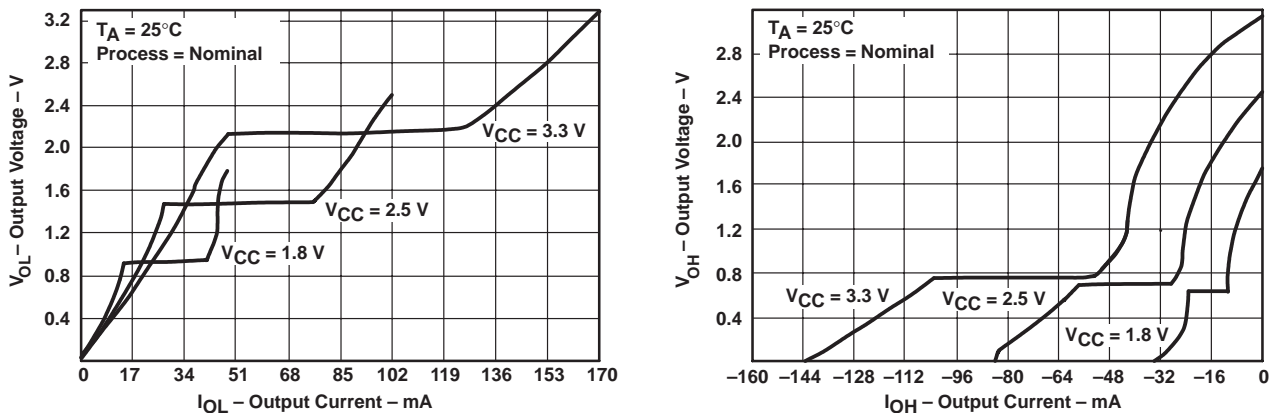

Figure 1. Output Voltage vs Output Current

This 18-bit universal bus driver is operational at 1.2-V to 3.6-V V_{CC} , but is designed specifically for 1.65-V to 3.6-V V_{CC} operation.

Data flow from A to Y is controlled by the output-enable (\overline{OE}) input. The device operates in the transparent mode when the latch-enable (LE) input is high. The A data is latched if the clock (CLK) input is held at a high or low logic level. If LE is low, the A data is stored in the latch/flip-flop on the low-to-high transition of CLK. When \overline{OE} is high, the outputs are in the high-impedance state.

To ensure the high-impedance state during power up or power down, \overline{OE} should be tied to V_{CC} through a pullup resistor; the minimum value of the resistor is determined by the current-sinking capability of the driver.



Please be aware that an important notice concerning availability, standard warranty, and use in critical applications of Texas Instruments semiconductor products and disclaimers thereto appears at the end of this data sheet.

DOC, EPIC, and Widebus are trademarks of Texas Instruments Incorporated.

PRODUCTION DATA information is current as of publication date. Products conform to specifications per the terms of Texas Instruments standard warranty. Production processing does not necessarily include testing of all parameters.



POST OFFICE BOX 655303 • DALLAS, TEXAS 75265

Copyright © 2000, Texas Instruments Incorporated

SN74AVC16835

18-BIT UNIVERSAL BUS DRIVER

WITH 3-STATE OUTPUTS

SCES168H – DECEMBER 1998 – REVISED FEBRUARY 2000

description (continued)

This device is fully specified for partial-power-down applications using I_{off} . The I_{off} circuitry disables the outputs, preventing damaging current backflow through the device when it is powered down.

The SN74AVC16835 is characterized for operation from -40°C to 85°C .

terminal assignments

DGG OR DGV PACKAGE
(TOP VIEW)

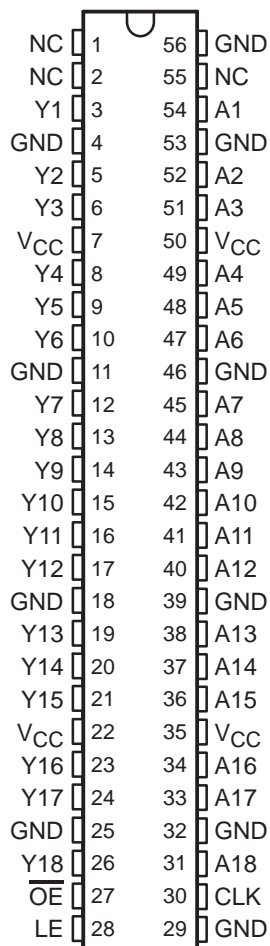

NC – No internal connection

SN74AVC16835
18-BIT UNIVERSAL BUS DRIVER
WITH 3-STATE OUTPUTS

SCES168H – DECEMBER 1998 – REVISED FEBRUARY 2000

FUNCTION TABLE
(each universal bus driver)

INPUTS				OUTPUT
\overline{OE}	LE	CLK	A	Y
H	X	X	X	Z
L	H	X	L	L
L	H	X	H	H
L	L	↑	L	L
L	L	↑	H	H
L	L	L or H	X	Y_0^\dagger

† Output level before the indicated steady-state input conditions were established, provided that CLK is high before LE goes low

logic symbol‡

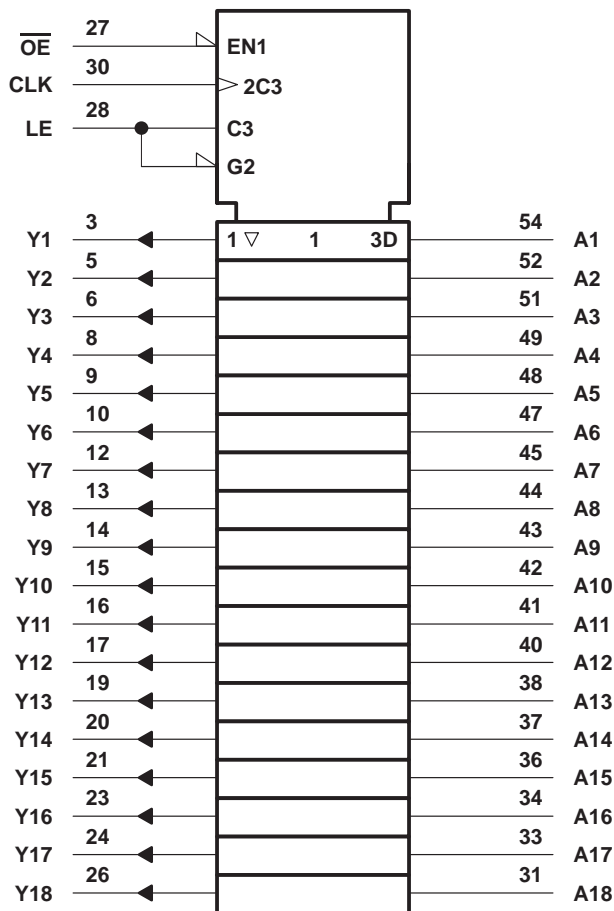

‡ This symbol is in accordance with ANSI/IEEE Std 91-1984 and IEC Publication 617-12.

SN74AVC16835
18-BIT UNIVERSAL BUS DRIVER
WITH 3-STATE OUTPUTS

SCES168H – DECEMBER 1998 – REVISED FEBRUARY 2000

recommended operating conditions (see Note 4)

		MIN	MAX	UNIT	
V _{CC}	Supply voltage	Operating	1.4	3.6	V
		Data retention only	1.2		
V _{IH}	High-level input voltage	V _{CC} = 1.2 V	V _{CC}		V
		V _{CC} = 1.4 V to 1.6 V	0.65 × V _{CC}		
		V _{CC} = 1.65 V to 1.95 V	0.65 × V _{CC}		
		V _{CC} = 2.3 V to 2.7 V	1.7		
		V _{CC} = 3 V to 3.6 V	2		
V _{IL}	Low-level input voltage	V _{CC} = 1.2 V	GND		V
		V _{CC} = 1.4 V to 1.6 V	0.35 × V _{CC}		
		V _{CC} = 1.65 V to 1.95 V	0.35 × V _{CC}		
		V _{CC} = 2.3 V to 2.7 V	0.7		
		V _{CC} = 3 V to 3.6 V	0.8		
V _I	Input voltage	0	3.6	V	
V _O	Output voltage	Active state	0	V _{CC}	V
		3-state	0	3.6	
I _{OHS}	Static high-level output current†	V _{CC} = 1.4 V to 1.6 V	–2		mA
		V _{CC} = 1.65 V to 1.95 V	–4		
		V _{CC} = 2.3 V to 2.7 V	–8		
		V _{CC} = 3 V to 3.6 V	–12		
I _{OLS}	Static low-level output current†	V _{CC} = 1.4 V to 1.6 V	2		mA
		V _{CC} = 1.65 V to 1.95 V	4		
		V _{CC} = 2.3 V to 2.7 V	8		
		V _{CC} = 3 V to 3.6 V	12		
Δt/Δv	Input transition rise or fall rate	V _{CC} = 1.4 V to 3.6 V		5	ns/V
T _A	Operating free-air temperature	–40	85	°C	

† Dynamic drive capability is equivalent to standard outputs with I_{OH} and I_{OL} of ±24 mA at 2.5-V V_{CC}. See Figure 1 for V_{OL} vs I_{OL} and V_{OH} vs I_{OH} characteristics. Refer to TI application reports *AVC Logic Family Technology and Applications*, literature number SCEA006, and *Dynamic Output Control (DOC™) Circuitry Technology and Applications*, literature number SCEA009.

NOTE 4: All unused inputs of the device must be held at V_{CC} or GND to ensure proper device operation. Refer to TI application report *Implications of Slow or Floating CMOS Inputs*, literature number SCBA004.

SN74AVC16835
18-BIT UNIVERSAL BUS DRIVER
WITH 3-STATE OUTPUTS

SCES168H – DECEMBER 1998 – REVISED FEBRUARY 2000

electrical characteristics over recommended operating free-air temperature range (unless otherwise noted)

PARAMETER		TEST CONDITIONS	V _{CC}	MIN	TYP†	MAX	UNIT
V _{OH}		I _{OHS} = -100 μA,	1.4 V to 3.6 V	V _{CC} -0.2			V
		I _{OHS} = -2 mA, V _{IH} = 0.91 V	1.4 V	1.05			
		I _{OHS} = -4 mA, V _{IH} = 1.07 V	1.65 V	1.2			
		I _{OHS} = -8 mA, V _{IH} = 1.7 V	2.3 V	1.75			
		I _{OHS} = -12 mA, V _{IH} = 2 V	3 V	2.3			
V _{OL}		I _{OLS} = 100 μA	1.4 V to 3.6 V			0.2	V
		I _{OLS} = 2 mA, V _{IL} = 0.49 V	1.4 V			0.4	
		I _{OLS} = 4 mA, V _{IL} = 0.57 V	1.65 V			0.45	
		I _{OLS} = 8 mA, V _{IL} = 0.7 V	2.3 V			0.55	
		I _{OLS} = 12 mA, V _{IL} = 0.8 V	3 V			0.7	
I _I	Control inputs	V _I = V _{CC} or GND	3.6 V			±2.5	μA
I _{off}		V _I or V _O = 3.6 V	0			±10	μA
I _{OZ}		V _O = V _{CC} or GND, \overline{OE} = V _{CC}	3.6 V			±10	μA
I _{CC}		V _I = V _{CC} or GND, I _O = 0	3.6 V			40	μA
C _i	CLK input	V _I = V _{CC} or GND	2.5 V			4	pF
			3.3 V			4	
	Control inputs	V _I = V _{CC} or GND	2.5 V			4	
			3.3 V			4	
	Data inputs	V _I = V _{CC} or GND	2.5 V			2.5	
			3.3 V			2.5	
C _o	Outputs	V _O = V _{CC} or GND	2.5 V			6.5	pF
			3.3 V			6.5	

† Typical values are measured at T_A = 25°C.

timing requirements over recommended operating free-air temperature range (unless otherwise noted) (see Figures 2 through 5)

		V _{CC} = 1.2 V		V _{CC} = 1.5 V ± 0.1 V		V _{CC} = 1.8 V ± 0.15 V		V _{CC} = 2.5 V ± 0.2 V		V _{CC} = 3.3 V ± 0.3 V		UNIT	
		MIN	MAX	MIN	MAX	MIN	MAX	MIN	MAX	MIN	MAX		
f _{clock}	Clock frequency					150		150		150		MHz	
t _w	Pulse duration	LE high				3.3		3.3		3.3		ns	
		CLK high or low				3.3		3.3		3.3			
t _{su}	Setup time	Data before CLK↑	1		0.9		0.7		0.7		0.7	ns	
		Data before LE↓	CLK high	1.7		1.6		1.2		0.8			0.8
			CLK low	2		0.9		0.7		0.5			0.5
t _h	Hold time	Data after CLK↑	1.5		1.3		1		0.9		1.3	ns	
		Data after LE↓	CLK high	3.2		2.4		2		1.7			1.6
			CLK low	2.8		2.1		1.7		1.5			1.4



SN74AVC16835
18-BIT UNIVERSAL BUS DRIVER
WITH 3-STATE OUTPUTS

SCES168H – DECEMBER 1998 – REVISED FEBRUARY 2000

switching characteristics over recommended operating free-air temperature range (unless otherwise noted) (see Figures 2 through 5)

PARAMETER	FROM (INPUT)	TO (OUTPUT)	V _{CC} = 1.2 V	V _{CC} = 1.5 V ± 0.1 V		V _{CC} = 1.8 V ± 0.15 V		V _{CC} = 2.5 V ± 0.2 V		V _{CC} = 3.3 V ± 0.3 V		UNIT
			TYP	MIN	MAX	MIN	MAX	MIN	MAX	MIN	MAX	
f _{max}						150		150		150		MHz
t _{pd}	A	Y	4.5	1.2	6.2	1.3	5.5	1	3.1	0.9	2.5	ns
	LE		6.2	1.6	9.4	1.3	7.2	1.1	4.7	0.9	3.8	
	CLK		5.2	1.6	7.8	1.5	6	1	3.7	0.8	3.1	
t _{en}	$\overline{\text{OE}}$	Y	7.1	2.4	10.2	2.2	8.8	1.5	6.7	1.2	6.2	ns
t _{dis}	$\overline{\text{OE}}$	Y	6.9	2.2	10.3	2	8.4	1.2	5.3	1.1	5.3	ns

switching characteristics, T_A = 0°C to 85°C, C_L = 0 pF†

PARAMETER	FROM (INPUT)	TO (OUTPUT)	V _{CC} = 3.3 V ± 0.15 V		UNIT
			MIN	MAX	
t _{pd}	A	Y	0.6	1.3	ns
	CLK		0.7	1.5	

† Texas Instruments SPICE simulation data

operating characteristics, T_A = 25°C

PARAMETER		TEST CONDITIONS	V _{CC} = 1.8 V	V _{CC} = 2.5 V	V _{CC} = 3.3 V	UNIT
			TYP	TYP	TYP	
C _{pd}	Power dissipation capacitance	C _L = 0, f = 10 MHz	45	48	52	pF
	Outputs disabled		23	25	28	



SN74AVC16835
18-BIT UNIVERSAL BUS DRIVER
WITH 3-STATE OUTPUTS

SCES168H – DECEMBER 1998 – REVISED FEBRUARY 2000

PARAMETER MEASUREMENT INFORMATION

$V_{CC} = 1.2\text{ V AND }1.5\text{ V} \pm 0.1\text{ V}$

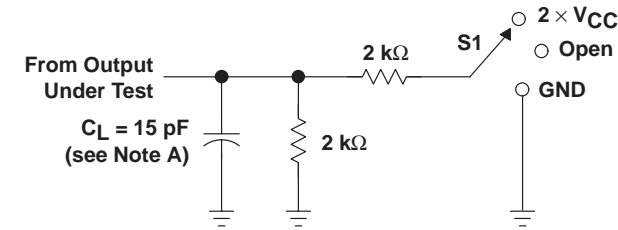

LOAD CIRCUIT

TEST	S1
t_{pd}	Open
t_{PLZ}/t_{PZL}	$2 \times V_{CC}$
t_{PHZ}/t_{PZH}	GND

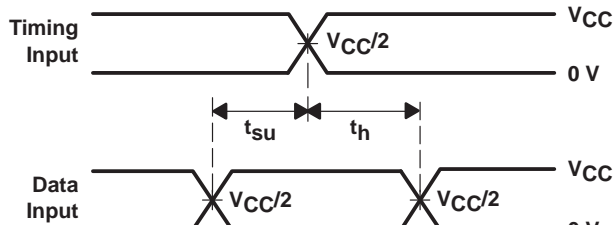

**VOLTAGE WAVEFORMS
SETUP AND HOLD TIMES**

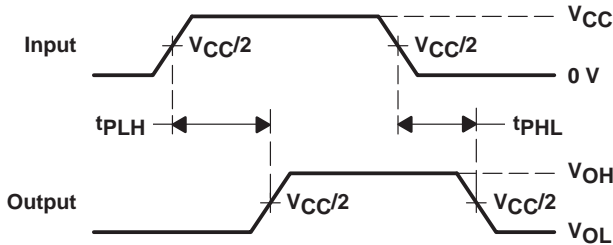

**VOLTAGE WAVEFORMS
PROPAGATION DELAY TIMES**

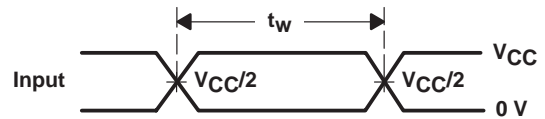

**VOLTAGE WAVEFORMS
PULSE DURATION**

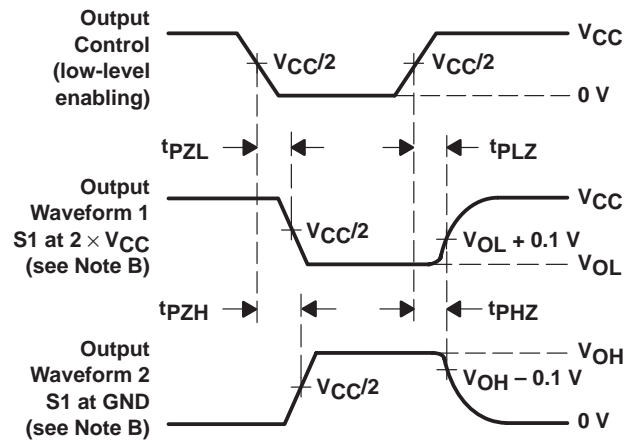

**VOLTAGE WAVEFORMS
ENABLE AND DISABLE TIMES**

- NOTES:
- A. C_L includes probe and jig capacitance.
 - B. Waveform 1 is for an output with internal conditions such that the output is low except when disabled by the output control. Waveform 2 is for an output with internal conditions such that the output is high except when disabled by the output control.
 - C. All input pulses are supplied by generators having the following characteristics: $PRR \leq 10\text{ MHz}$, $Z_O = 50\ \Omega$, $t_r \leq 2\text{ ns}$, $t_f \leq 2\text{ ns}$.
 - D. The outputs are measured one at a time with one transition per measurement.
 - E. t_{PLZ} and t_{PHZ} are the same as t_{dis} .
 - F. t_{PZL} and t_{PZH} are the same as t_{en} .
 - G. t_{PLH} and t_{PHL} are the same as t_{pd} .

Figure 2. Load Circuit and Voltage Waveforms

PARAMETER MEASUREMENT INFORMATION

$V_{CC} = 1.8\text{ V} \pm 0.15\text{ V}$

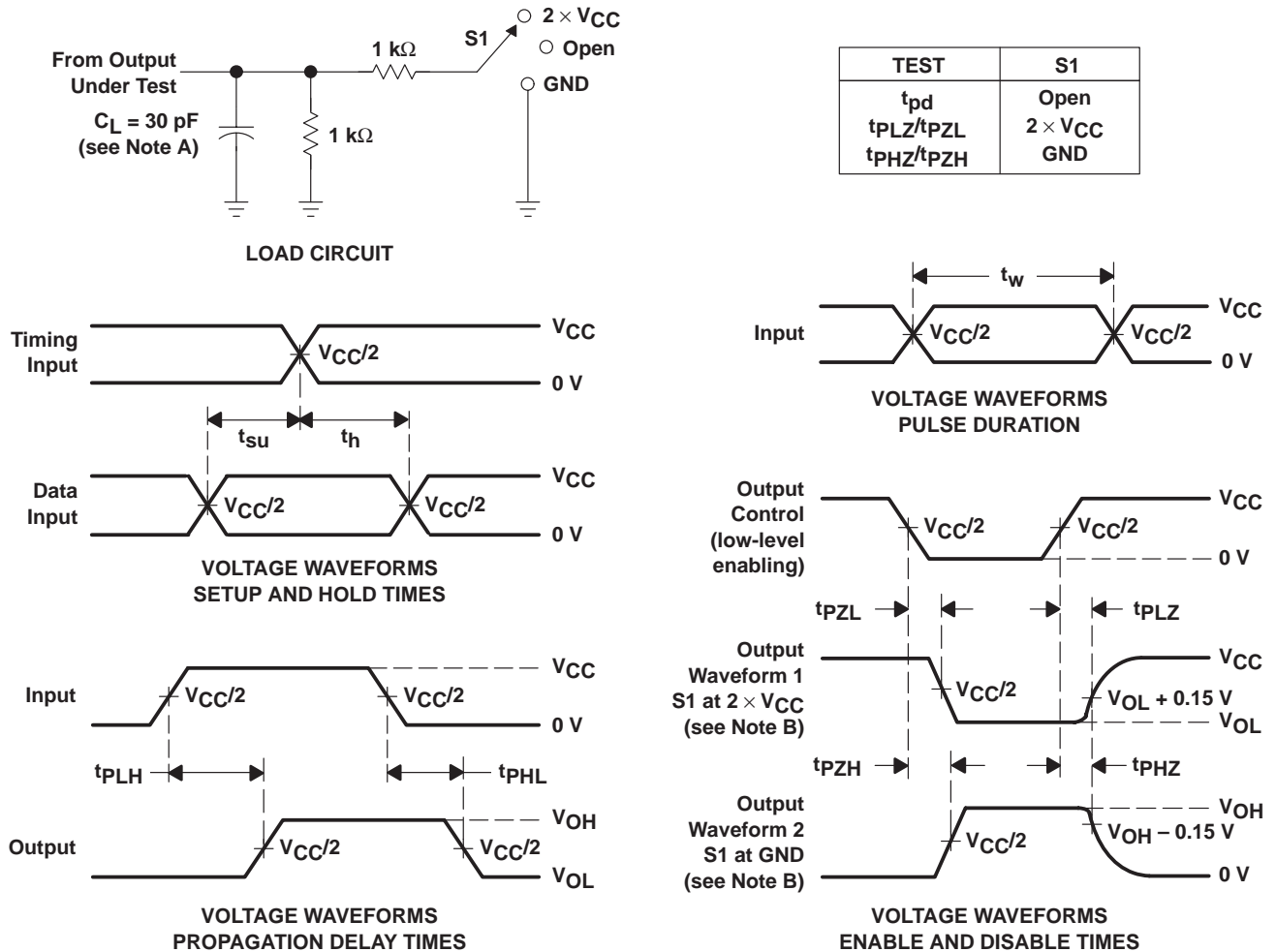

- NOTES:
- A. C_L includes probe and jig capacitance.
 - B. Waveform 1 is for an output with internal conditions such that the output is low except when disabled by the output control. Waveform 2 is for an output with internal conditions such that the output is high except when disabled by the output control.
 - C. All input pulses are supplied by generators having the following characteristics: PRR $\leq 10\text{ MHz}$, $Z_O = 50\ \Omega$, $t_r \leq 2\text{ ns}$, $t_f \leq 2\text{ ns}$.
 - D. The outputs are measured one at a time with one transition per measurement.
 - E. t_{PLZ} and t_{PHZ} are the same as t_{dis} .
 - F. t_{PZL} and t_{PZH} are the same as t_{en} .
 - G. t_{PLH} and t_{PHL} are the same as t_{pd} .

Figure 3. Load Circuit and Voltage Waveforms

SN74AVC16835
18-BIT UNIVERSAL BUS DRIVER
WITH 3-STATE OUTPUTS

SCES168H – DECEMBER 1998 – REVISED FEBRUARY 2000

PARAMETER MEASUREMENT INFORMATION

$V_{CC} = 2.5\text{ V} \pm 0.2\text{ V}$

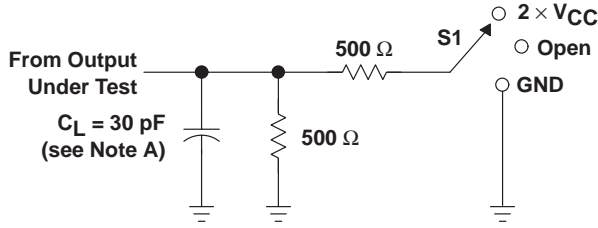

LOAD CIRCUIT

TEST	S1
t_{pd}	Open
t_{PLZ}/t_{PZL}	$2 \times V_{CC}$
t_{PHZ}/t_{PZH}	GND

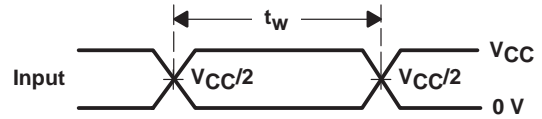

VOLTAGE WAVEFORMS PULSE DURATION

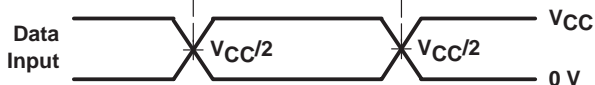

VOLTAGE WAVEFORMS SETUP AND HOLD TIMES

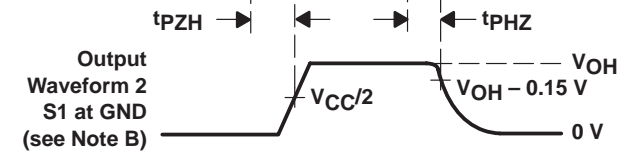
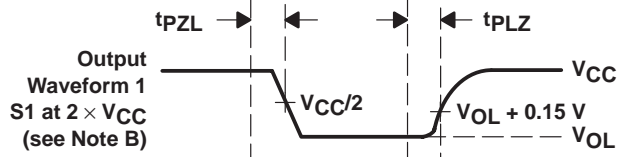
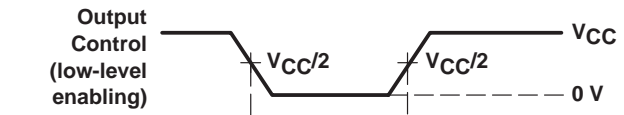

VOLTAGE WAVEFORMS ENABLE AND DISABLE TIMES



VOLTAGE WAVEFORMS PROPAGATION DELAY TIMES

- NOTES:
- A. C_L includes probe and jig capacitance.
 - B. Waveform 1 is for an output with internal conditions such that the output is low except when disabled by the output control. Waveform 2 is for an output with internal conditions such that the output is high except when disabled by the output control.
 - C. All input pulses are supplied by generators having the following characteristics: $PRR \leq 10\text{ MHz}$, $Z_O = 50\ \Omega$, $t_r \leq 2\text{ ns}$, $t_f \leq 2\text{ ns}$.
 - D. The outputs are measured one at a time with one transition per measurement.
 - E. t_{PLZ} and t_{PHZ} are the same as t_{dis} .
 - F. t_{PZL} and t_{PZH} are the same as t_{en} .
 - G. t_{PLH} and t_{PHL} are the same as t_{pd} .

Figure 4. Load Circuit and Voltage Waveforms

PARAMETER MEASUREMENT INFORMATION

$V_{CC} = 3.3\text{ V} \pm 0.3\text{ V}$

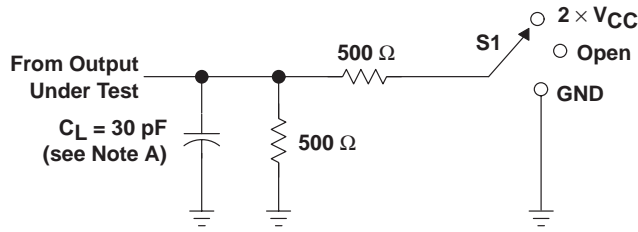

LOAD CIRCUIT

TEST	S1
t_{pd}	Open
t_{PLZ}/t_{PZL}	2 \times V_{CC}
t_{PHZ}/t_{PZH}	GND

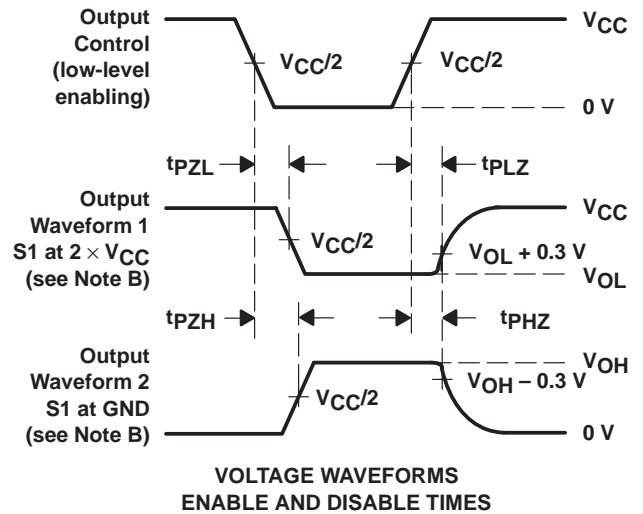
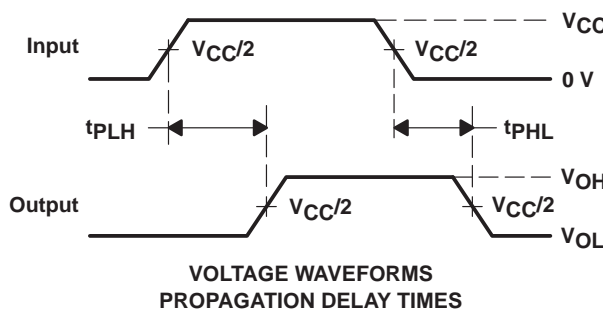
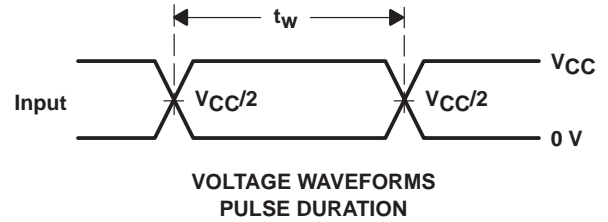
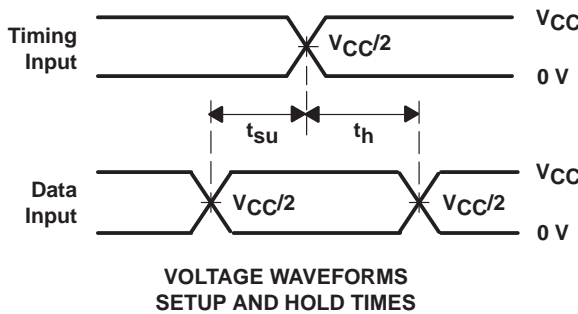

- NOTES:
- C_L includes probe and jig capacitance.
 - Waveform 1 is for an output with internal conditions such that the output is low except when disabled by the output control. Waveform 2 is for an output with internal conditions such that the output is high except when disabled by the output control.
 - All input pulses are supplied by generators having the following characteristics: PRR $\leq 10\text{ MHz}$, $Z_O = 50\ \Omega$, $t_r \leq 2\text{ ns}$, $t_f \leq 2\text{ ns}$.
 - The outputs are measured one at a time with one transition per measurement.
 - t_{PLZ} and t_{PHZ} are the same as t_{dis} .
 - t_{PZL} and t_{PZH} are the same as t_{en} .
 - t_{PLH} and t_{PHL} are the same as t_{pd} .

Figure 5. Load Circuit and Voltage Waveforms

IMPORTANT NOTICE

Texas Instruments and its subsidiaries (TI) reserve the right to make changes to their products or to discontinue any product or service without notice, and advise customers to obtain the latest version of relevant information to verify, before placing orders, that information being relied on is current and complete. All products are sold subject to the terms and conditions of sale supplied at the time of order acknowledgement, including those pertaining to warranty, patent infringement, and limitation of liability.

TI warrants performance of its semiconductor products to the specifications applicable at the time of sale in accordance with TI's standard warranty. Testing and other quality control techniques are utilized to the extent TI deems necessary to support this warranty. Specific testing of all parameters of each device is not necessarily performed, except those mandated by government requirements.

CERTAIN APPLICATIONS USING SEMICONDUCTOR PRODUCTS MAY INVOLVE POTENTIAL RISKS OF DEATH, PERSONAL INJURY, OR SEVERE PROPERTY OR ENVIRONMENTAL DAMAGE ("CRITICAL APPLICATIONS"). TI SEMICONDUCTOR PRODUCTS ARE NOT DESIGNED, AUTHORIZED, OR WARRANTED TO BE SUITABLE FOR USE IN LIFE-SUPPORT DEVICES OR SYSTEMS OR OTHER CRITICAL APPLICATIONS. INCLUSION OF TI PRODUCTS IN SUCH APPLICATIONS IS UNDERSTOOD TO BE FULLY AT THE CUSTOMER'S RISK.

In order to minimize risks associated with the customer's applications, adequate design and operating safeguards must be provided by the customer to minimize inherent or procedural hazards.

TI assumes no liability for applications assistance or customer product design. TI does not warrant or represent that any license, either express or implied, is granted under any patent right, copyright, mask work right, or other intellectual property right of TI covering or relating to any combination, machine, or process in which such semiconductor products or services might be or are used. TI's publication of information regarding any third party's products or services does not constitute TI's approval, warranty or endorsement thereof.