

SN74CBT16233

16-BIT 1-OF-2 FET MULTIPLEXER/DEMULTIPLEXER

SCDS010H – MAY 1995 – REVISED OCTOBER 1998

- 5-Ω Switch Connection Between Two Ports
- TTL-Compatible Input Levels
- Package Options Include Plastic Thin Shrink Small-Outline (DGG), Thin Very Small-Outline (DGV), and 300-mil Shrink Small-Outline (DL) Packages

description

The SN74CBT16233 is a 16-bit 1-of-2 FET multiplexer/demultiplexer used in applications in which two separate data paths must be multiplexed onto, or demultiplexed from, a single path. This device can be used for memory interleaving, where two different banks of memory need to be addressed simultaneously. The device can be used as two 8-bit to 16-bit multiplexers or as one 16-bit to 32-bit multiplexer.

Two select (SEL1 and SEL2) inputs control the data flow. When the TEST inputs are asserted, the A port is connected to both the B1 and the B2 ports. SEL1, SEL2, and the TEST inputs can be driven with a 5-V CMOS, a 5-V TTL, or a low-voltage TTL driver.

The device is specified by design not to have through current when switching directions.

The SN74CBT16233 is characterized for operation from 0°C to 70°C.

**DGG, DGV, OR DL PACKAGE
(TOP VIEW)**

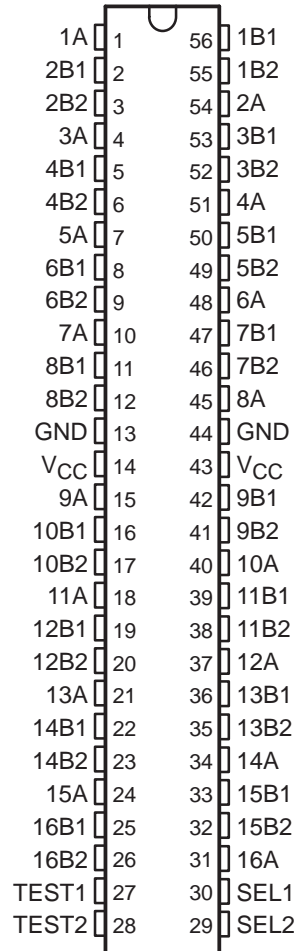

**FUNCTION TABLE
(each multiplexer/demultiplexer)**

INPUTS		FUNCTION
SEL	TEST	
L	L	A = B1
H	L	A = B2
X	H	A = B1 and A = B2



Please be aware that an important notice concerning availability, standard warranty, and use in critical applications of Texas Instruments semiconductor products and disclaimers thereto appears at the end of this data sheet.

PRODUCTION DATA information is current as of publication date. Products conform to specifications per the terms of Texas Instruments standard warranty. Production processing does not necessarily include testing of all parameters.



POST OFFICE BOX 655303 • DALLAS, TEXAS 75265

Copyright © 1998, Texas Instruments Incorporated

SN74CBT16233

16-BIT 1-OF-2 FET MULTIPLEXER/DEMULTIPLEXER

SCDS010H – MAY 1995 – REVISED OCTOBER 1998

electrical characteristics over recommended operating free-air temperature range (unless otherwise noted)

PARAMETER		TEST CONDITIONS		MIN	TYP†	MAX	UNIT	
V_{IK}		$V_{CC} = 4.75\text{ V}$, $I_I = -18\text{ mA}$				-1.2	V	
I_I		$V_{CC} = 0$, $V_I = 5.25\text{ V}$				10	μA	
		$V_{CC} = 5.25\text{ V}$, $V_I = 5.25\text{ V or GND}$				± 1	μA	
I_{CC}		$V_{CC} = 5.25\text{ V}$, $I_O = 0$, $V_I = V_{CC}\text{ or GND}$				3	μA	
$\Delta I_{CC}‡$	Control inputs	$V_{CC} = 5.5\text{ V}$, One input at 3.4 V, Other inputs at $V_{CC}\text{ or GND}$				2.5	mA	
C_i	Control inputs	$V_I = 3\text{ V or 0}$				4.5	pF	
$C_{iO(OFF)}$		$V_O = 3\text{ V or 0}$				4	pF	
$r_{on}§$		$V_{CC} = 4.75\text{ V}$	$V_I = 0$			5	7	Ω
						5	7	
			$V_I = 2.4\text{ V}$,	$I_I = 15\text{ mA}$	7	12		

† All typical values are at $V_{CC} = 5\text{ V}$, $T_A = 25^\circ\text{C}$.

‡ This is the increase in supply current for each input that is at the specified TTL voltage level rather than V_{CC} or GND.

§ Measured by the voltage drop between A and B terminals at the indicated current through the switch. On-state resistance is determined by the lower of the voltages of the two (A or B) terminals.

switching characteristics over recommended operating free-air temperature range, $C_L = 50\text{ pF}$ (unless otherwise noted) (see Figure 1)

PARAMETER	FROM (INPUT)	TO (OUTPUT)	MIN	MAX	UNIT
$t_{pd}¶$	A or B	B or A		0.25	ns
t_{pd}	SEL	A	1.6	5.3	ns
t_{en}	TEST or SEL	B	1.3	5.2	ns
t_{dis}	TEST or SEL	B	1	5.3	ns

¶ The propagation delay is the calculated RC time constant of the typical on-state resistance of the switch and the specified load capacitance, when driven by an ideal voltage source (zero output impedance).

SN74CBT16233

16-BIT 1-OF-2 FET MULTIPLEXER/DEMULTIPLEXER

SCDS010H – MAY 1995 – REVISED OCTOBER 1998

PARAMETER MEASUREMENT INFORMATION

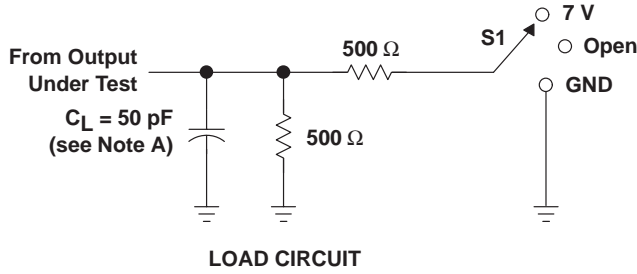

TEST	S1
t_{pd}	Open
t_{PLZ}/t_{PZL}	7 V
t_{PHZ}/t_{PZH}	Open

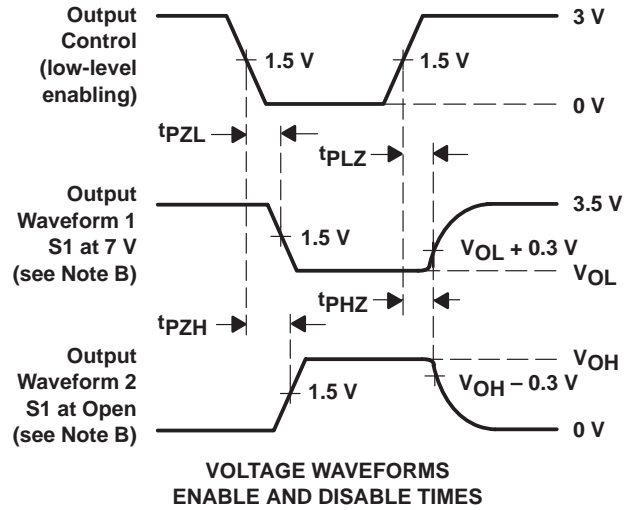
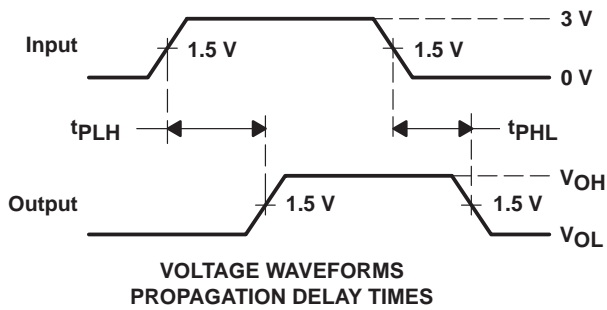

- NOTES:
- C_L includes probe and jig capacitance.
 - Waveform 1 is for an output with internal conditions such that the output is low except when disabled by the output control. Waveform 2 is for an output with internal conditions such that the output is high except when disabled by the output control.
 - All input pulses are supplied by generators having the following characteristics: $PRR \leq 10 \text{ MHz}$, $Z_O = 50 \Omega$, $t_r \leq 2.5 \text{ ns}$, $t_f \leq 2.5 \text{ ns}$.
 - The outputs are measured one at a time with one transition per measurement.
 - t_{PLZ} and t_{PHZ} are the same as t_{dis} .
 - t_{PZL} and t_{PZH} are the same as t_{en} .
 - t_{PLH} and t_{PHL} are the same as t_{pd} .

Figure 1. Load Circuit and Voltage Waveforms

IMPORTANT NOTICE

Texas Instruments and its subsidiaries (TI) reserve the right to make changes to their products or to discontinue any product or service without notice, and advise customers to obtain the latest version of relevant information to verify, before placing orders, that information being relied on is current and complete. All products are sold subject to the terms and conditions of sale supplied at the time of order acknowledgement, including those pertaining to warranty, patent infringement, and limitation of liability.

TI warrants performance of its semiconductor products to the specifications applicable at the time of sale in accordance with TI's standard warranty. Testing and other quality control techniques are utilized to the extent TI deems necessary to support this warranty. Specific testing of all parameters of each device is not necessarily performed, except those mandated by government requirements.

CERTAIN APPLICATIONS USING SEMICONDUCTOR PRODUCTS MAY INVOLVE POTENTIAL RISKS OF DEATH, PERSONAL INJURY, OR SEVERE PROPERTY OR ENVIRONMENTAL DAMAGE ("CRITICAL APPLICATIONS"). TI SEMICONDUCTOR PRODUCTS ARE NOT DESIGNED, AUTHORIZED, OR WARRANTED TO BE SUITABLE FOR USE IN LIFE-SUPPORT DEVICES OR SYSTEMS OR OTHER CRITICAL APPLICATIONS. INCLUSION OF TI PRODUCTS IN SUCH APPLICATIONS IS UNDERSTOOD TO BE FULLY AT THE CUSTOMER'S RISK.

In order to minimize risks associated with the customer's applications, adequate design and operating safeguards must be provided by the customer to minimize inherent or procedural hazards.

TI assumes no liability for applications assistance or customer product design. TI does not warrant or represent that any license, either express or implied, is granted under any patent right, copyright, mask work right, or other intellectual property right of TI covering or relating to any combination, machine, or process in which such semiconductor products or services might be or are used. TI's publication of information regarding any third party's products or services does not constitute TI's approval, warranty or endorsement thereof.