

SN74HC4851-Q1

8-CHANNEL ANALOG MULTIPLEXER/DEMUTIPLEXER WITH INJECTION-CURRENT EFFECT CONTROL

SCLS554A – JANUARY 2004 – REVISED MARCH 2004

- Qualification in Accordance With AEC-Q100†
- Qualified for Automotive Applications
- Customer-Specific Configuration Control Can Be Supported Along With Major-Change Approval
- Injection-Current Cross Coupling <math><1\text{mV}/\text{mA}</math> (see Figure 1)
- Low Crosstalk Between Switches
- Pin Compatible With CD74HC4051, SN74LV4051A, and CD4051B
- 2-V to 6-V V_{CC} Operation
- Latch-Up Performance Exceeds 100 mA Per JESD 78, Class II

† Contact factory for details. Q100 qualification data available on request.

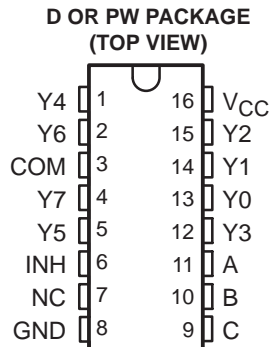

NC – No internal connection

description/ordering information

This eight-channel CMOS analog multiplexer/demultiplexer is pin compatible with the '4051 function and, additionally, features injection-current effect control, which has excellent value in automotive applications where voltages in excess of normal supply voltages are common.

The injection-current effect control allows signals at disabled analog input channels to exceed the supply voltage without affecting the signal of the enabled analog channel. This eliminates the need for external diode/resistor networks typically used to keep the analog channel signals within the supply-voltage range.

ORDERING INFORMATION

T_A	PACKAGE‡		ORDERABLE PART NUMBER	TOP-SIDE MARKING
–40°C to 125°C	SOIC – D	Tape and reel	SN74HC4851QDRQ1	HC4851Q
	TSSOP – PW	Tape and reel	SN74HC4851QPWRQ1	HC4851Q

‡ Package drawings, standard packing quantities, thermal data, symbolization, and PCB design guidelines are available at www.ti.com/sc/package.

FUNCTION TABLE

INH	INPUTS			ON CHANNEL
	C	B	A	
L	L	L	L	Y0
L	L	L	H	Y1
L	L	H	L	Y2
L	L	H	H	Y3
L	H	L	L	Y4
L	H	L	H	Y5
L	H	H	L	Y6
L	H	H	H	Y7
H	X	X	X	None



Please be aware that an important notice concerning availability, standard warranty, and use in critical applications of Texas Instruments semiconductor products and disclaimers thereto appears at the end of this data sheet.

PRODUCTION DATA information is current as of publication date. Products conform to specifications per the terms of Texas Instruments standard warranty. Production processing does not necessarily include testing of all parameters.

**TEXAS
INSTRUMENTS**

POST OFFICE BOX 655303 • DALLAS, TEXAS 75265

Copyright © 2004, Texas Instruments Incorporated

SN74HC4851-Q1

8-CHANNEL ANALOG MULTIPLEXER/DEMULTIPLEXER

WITH INJECTION-CURRENT EFFECT CONTROL

SCLS554A – JANUARY 2004 – REVISED MARCH 2004

logic diagram (positive logic)

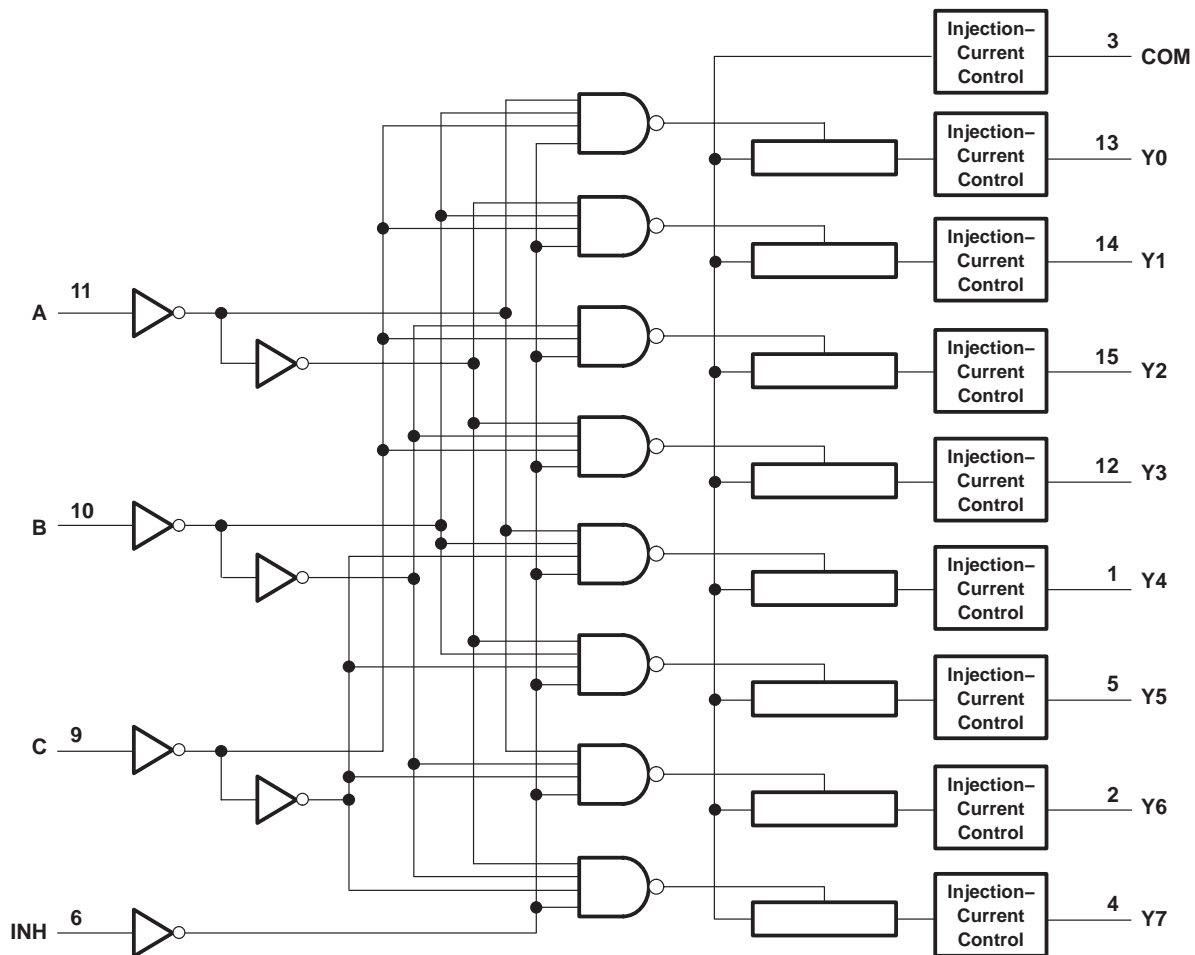

SN74HC4851-Q1

8-CHANNEL ANALOG MULTIPLEXER/DEMULTIPLEXER WITH INJECTION-CURRENT EFFECT CONTROL

SCLS554A – JANUARY 2004 – REVISED MARCH 2004

absolute maximum ratings over operating free-air temperature range (unless otherwise noted)†

Supply voltage range, V_{CC}	–0.5 V to 7 V
Input voltage range, V_I (see Note 1)	–0.5 V to $V_{CC} + 0.5$ V
Switch I/O voltage range, V_{IO} (see Notes 1 and 2)	–0.5 V to $V_{CC} + 0.5$ V
Input clamp current, I_{IK} ($V_I < 0$ or $V_I > V_{CC}$)	±20 mA
I/O diode current, I_{IOK} ($V_{IO} < 0$ or $V_{IO} > V_{CC}$)	±20 mA
Switch through current, I_T ($V_{IO} = 0$ to V_{CC})	±25 mA
Continuous current through V_{CC} or GND	±50 mA
Package thermal impedance, θ_{JA} (see Note 3): D package	73°C/W
PW package	108°C/W
Storage temperature range, T_{stg}	–65°C to 150°C

† Stresses beyond those listed under “absolute maximum ratings” may cause permanent damage to the device. These are stress ratings only, and functional operation of the device at these or any other conditions beyond those indicated under “recommended operating conditions” is not implied. Exposure to absolute-maximum-rated conditions for extended periods may affect device reliability.

- NOTES: 1. The input and output voltage ratings may be exceeded if the input and output current ratings are observed.
 2. This value is limited to 5.5 V maximum.
 3. The package thermal impedance is calculated in accordance with JESD 51-7.

recommended operating conditions (see Note 4)

		MIN	MAX	UNIT
V_{CC}	Supply voltage	2	6	V
V_{IH}	High-level input voltage, control inputs	$V_{CC} = 2$ V	1.5	V
		$V_{CC} = 3$ V	2.1	
		$V_{CC} = 3.3$ V	2.3	
		$V_{CC} = 4.5$ V	3.15	
		$V_{CC} = 6$ V	4.2	
V_{IL}	Low-level input voltage, control inputs	$V_{CC} = 2$ V	0.5	V
		$V_{CC} = 3$ V	0.9	
		$V_{CC} = 3.3$ V	1	
		$V_{CC} = 4.5$ V	1.35	
		$V_{CC} = 6$ V	1.8	
V_I	Control input voltage	0	V_{CC}	V
V_{IO}	Input/output voltage	0	V_{CC}	V
$\Delta t/\Delta v$	Input transition rise or fall time	$V_{CC} = 2$ V	1000	ns
		$V_{CC} = 3$ V	800	
		$V_{CC} = 3.3$ V	700	
		$V_{CC} = 4.5$ V	500	
		$V_{CC} = 6$ V	400	
T_A	Operating free-air temperature	–40	125	°C

NOTE 4: All unused inputs of the device must be held at V_{CC} or GND to ensure proper device operation. Refer to the TI application report, *Implications of Slow or Floating CMOS Inputs*, literature number SCBA004.



SN74HC4851-Q1

8-CHANNEL ANALOG MULTIPLEXER/DEMULTIPLEXER WITH INJECTION-CURRENT EFFECT CONTROL

SCLS554A – JANUARY 2004 – REVISED MARCH 2004

electrical characteristics over recommended operating free-air temperature range (unless otherwise noted)

PARAMETER		TEST CONDITIONS	V _{CC}	T _A = 25°C			UP TO 85°C		UP TO 125°C		UNIT
				MIN	TYP	MAX	MIN	MAX	MIN	MAX	
r _{on}	On-state switch resistance	I _T ≤ 2 mA, V _I = V _{CC} to GND, V _{INH} = V _{IL} (see Figure 5)	2. V		500	650		670		700	Ω
			3 V		215	280		320		360	
			3.3 V		210	270		305		345	
			4.5 V		160	210		240		270	
			6 V		150	195		220		250	
Δr _{on}	Difference in on-state resistance between switches	I _T ≤ 2 mA, V _I = V _{CC} /2, V _{INH} = V _{IL}	2. V		4	13		18		23	Ω
			3 V		2	10		12		16	
			3.3 V		2	9		12		16	
			4.5 V		2	9		12		16	
			6 V		3	10		14		19	
I _I	Control input current	V _I = V _{CC} or GND	6 V			±0.1		±0.1		±1	μA
I _{S(off)}	Off-state switch leakage current (any one channel)	V _I = V _{CC} or GND, V _{INH} = V _{IH} (see Figure 6)	6 V			±0.1		±0.5		±1	μA
	Off-state switch leakage current (common channel)	V _I = V _{CC} or GND, V _{INH} = V _{IH} (see Figure 7)				±0.2		±2		±4	
I _{S(on)}	On-state switch leakage current	V _I = V _{CC} or GND, V _{INH} = V _{IL} (see Figure 8)	6 V			±0.1		±0.5		±1	μA
I _{CC}	Supply current	V _I = V _{CC} or GND	6 V			2		20		40	μA
C _{IC}	Control input capacitance	A, B, C, INH			3.5	10		10		10	pF
C _{IS}	Common terminal capacitance	Switch off			22	40		40		40	pF
C _{OS}	Switch terminal capacitance	Switch off			6.7	15		15		15	pF

injection current coupling specifications, T_A = -40°C to 125°C

PARAMETER		V _{CC}	TEST CONDITIONS		MIN	TYP†	MAX	UNIT
V _{Δout}	Maximum shift of output voltage of enabled analog channel	3.3 V	R _S ≤ 3.9 kΩ	I _I ‡ ≤ 1 mA	0.05	1	mV	
		5 V			0.1	1		
		3.3 V		I _I ‡ ≤ 10 mA	0.345	5		
		5 V			0.067	5		
		3.3 V	R _S ≤ 20 kΩ	I _I ‡ ≤ 1 mA	0.05	2		
		5 V			0.11	2		
		3.3 V		I _I ‡ ≤ 10 mA	0.05	20		
		5 V			0.024	20		

† Typical values are measured at T_A = 25°C.

‡ I_I = total current injected into all disabled channels



SN74HC4851-Q1
8-CHANNEL ANALOG MULTIPLEXER/DEMULTIPLEXER
WITH INJECTION-CURRENT EFFECT CONTROL

SCLS554A – JANUARY 2004 – REVISED MARCH 2004

**switching characteristics over recommended operating free-air temperature range,
 $V_{CC} = 2\text{ V}$, $C_L = 50\text{ pF}$ (unless otherwise noted) (see Figures 9–14)**

PARAMETER	FROM (INPUT)	TO (OUTPUT)	$T_A = 25^\circ\text{C}$			UP TO 85°C		UP TO 125°C		UNIT
			MIN	TYP	MAX	MIN	MAX	MIN	MAX	
tPLH tPHL	Propagation delay time	COM or Yn		19.5	30		34		37	ns
tPLH tPHL	Propagation delay time	A, B, C		23	35		40		45	ns
tPZH tPZL	Enable delay time	INH			95		105		115	ns
tPHZ tPLZ	Disable delay time	INH			95		105		115	ns

**switching characteristics over recommended operating free-air temperature range,
 $V_{CC} = 3\text{ V}$, $C_L = 50\text{ pF}$ (unless otherwise noted) (see Figures 9–14)**

PARAMETER	FROM (INPUT)	TO (OUTPUT)	$T_A = 25^\circ\text{C}$			UP TO 85°C		UP TO 125°C		UNIT
			MIN	TYP	MAX	MIN	MAX	MIN	MAX	
tPLH tPHL	Propagation delay time	COM or Yn		12	17.5		19.5		21.5	ns
tPLH tPHL	Propagation delay time	A, B, C		13.5	19.5		22		25	ns
tPZH tPZL	Enable delay time	INH			90		100		110	ns
tPHZ tPLZ	Disable delay time	INH			90		100		110	ns

**switching characteristics over recommended operating free-air temperature range,
 $V_{CC} = 3.3\text{ V}$, $C_L = 50\text{ pF}$ (unless otherwise noted) (see Figures 9–14)**

PARAMETER	FROM (INPUT)	TO (OUTPUT)	$T_A = 25^\circ\text{C}$			UP TO 85°C		UP TO 125°C		UNIT
			MIN	TYP	MAX	MIN	MAX	MIN	MAX	
tPLH tPHL	Propagation delay time	COM or Yn		11	16.5		18.5		20.5	ns
tPLH tPHL	Propagation delay time	A, B, C		12.5	18.5		21		24	ns
tPZH tPZL	Enable delay time	INH			85		95		105	ns
tPHZ tPLZ	Disable delay time	INH			85		95		105	ns

SN74HC4851-Q1
8-CHANNEL ANALOG MULTIPLEXER/DEMUTIPLEXER
WITH INJECTION-CURRENT EFFECT CONTROL

SCLS554A – JANUARY 2004 – REVISED MARCH 2004

switching characteristics over recommended operating free-air temperature range,
 $V_{CC} = 4.5\text{ V}$, $C_L = 50\text{ pF}$ (unless otherwise noted) (see Figures 9–14)

PARAMETER	FROM (INPUT)	TO (OUTPUT)	$T_A = 25^\circ\text{C}$			UP TO 85°C		UP TO 125°C		UNIT
			MIN	TYP	MAX	MIN	MAX	MIN	MAX	
tPLH tPHL	Propagation delay time	COM or Yn		8.6	14		15		16	ns
tPLH tPHL	Propagation delay time	A, B, C		10	16		18		20	ns
tPZH tPZL	Enable delay time	INH			80		90		100	ns
tPHZ tPLZ	Disable delay time	INH			80		90		100	ns

switching characteristics over recommended operating free-air temperature range,
 $V_{CC} = 6\text{ V}$, $C_L = 50\text{ pF}$ (unless otherwise noted) (see Figures 9–14)

PARAMETER	FROM (INPUT)	TO (OUTPUT)	$T_A = 25^\circ\text{C}$			UP TO 85°C		UP TO 125°C		UNIT
			MIN	TYP	MAX	MIN	MAX	MIN	MAX	
tPLH tPHL	Propagation delay time	COM or Yn		8	12.5		13.5		14.5	ns
tPLH tPHL	Propagation delay time	A, B, C		9.5	15		17		19	ns
tPZH tPZL	Enable delay time	INH			78		80		80	ns
tPHZ tPLZ	Disable delay time	INH			78		80		80	ns

operating characteristics, $T_A = 25^\circ\text{C}$ (see Figure 15)

PARAMETER		V_{CC}	TEST CONDITIONS	TYP	UNIT
Cpd	Power dissipation capacitance	3.3 V	No load	32	pF
		5 V		37	



SN74HC4851-Q1
8-CHANNEL ANALOG MULTIPLEXER/DEMULTIPLEXER
WITH INJECTION-CURRENT EFFECT CONTROL

SCLS554A – JANUARY 2004 – REVISED MARCH 2004

APPLICATION INFORMATION

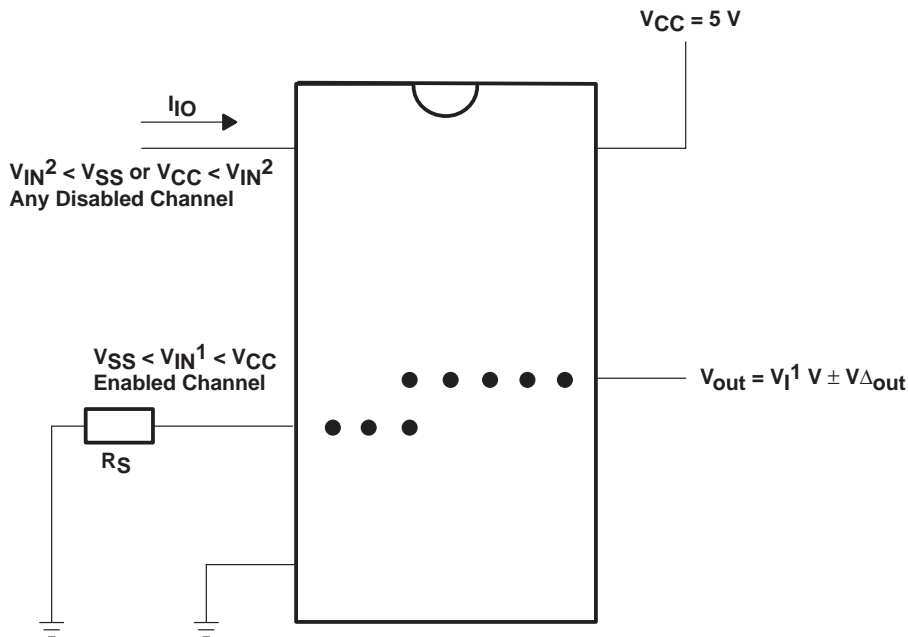

Figure 1. Injection-Current Coupling Specification

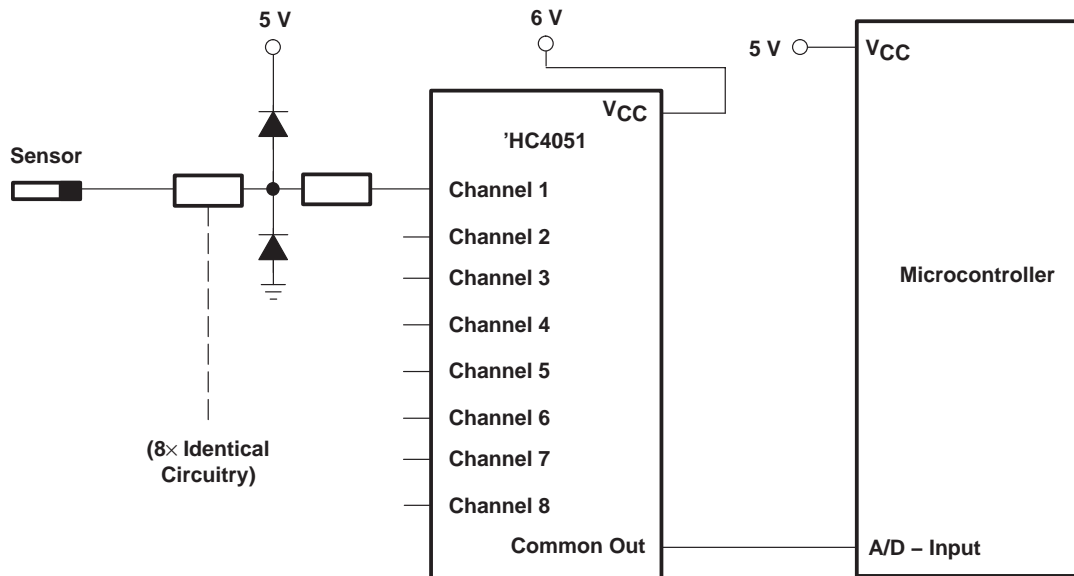

Figure 2. Alternate Solution Requires 32 Passive Components and One Extra 6-V Regulator to Suppress Injection Current Into a Standard 'HC4051 Multiplexer

SN74HC4851-Q1
8-CHANNEL ANALOG MULTIPLEXER/DEMULTIPLEXER
WITH INJECTION-CURRENT EFFECT CONTROL

SCLS554A – JANUARY 2004 – REVISED MARCH 2004

APPLICATION INFORMATION

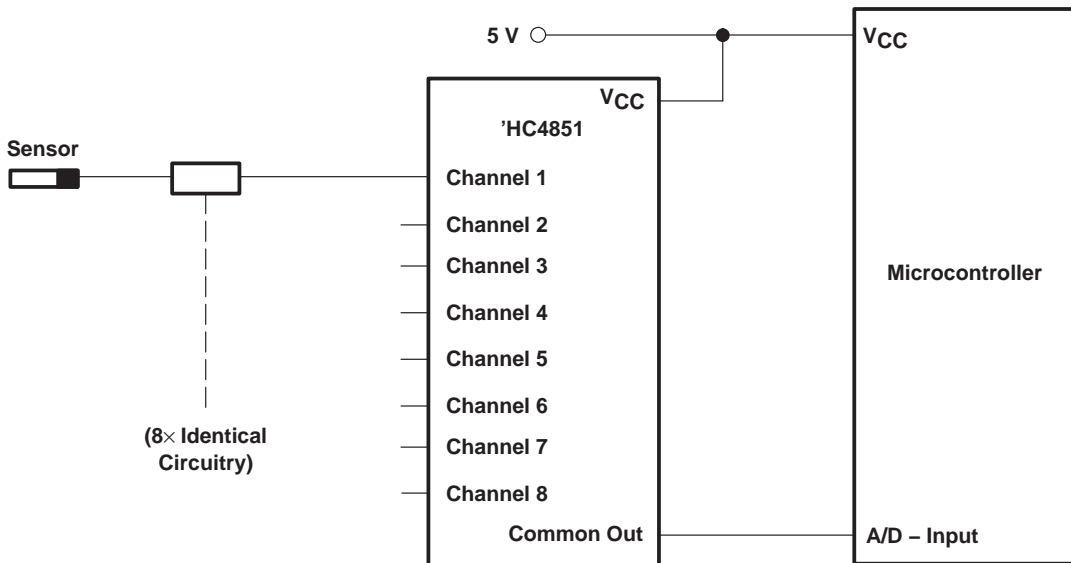

Figure 3. Solution by Applying the 'HC4851 Multiplexer

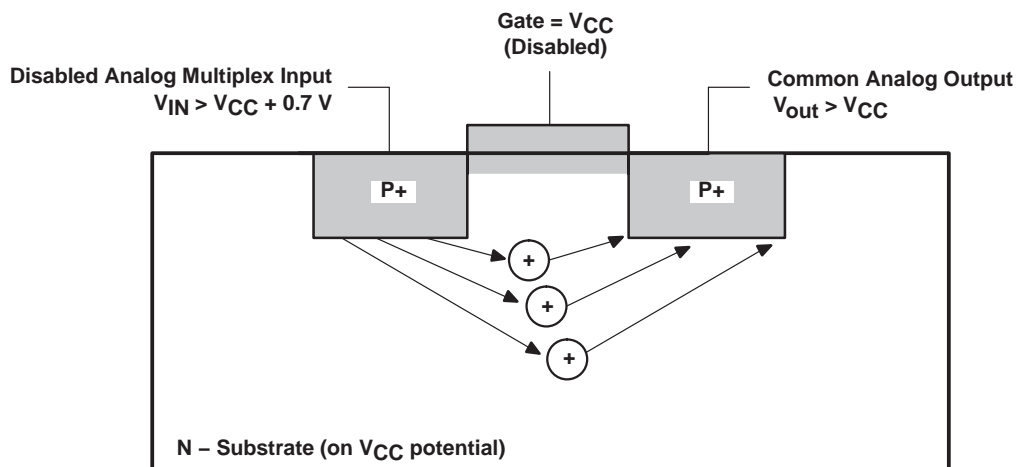

Figure 4. Diagram of Bipolar Coupling Mechanism
(Appears if V_{IN} Exceeds V_{CC} , Driving Injection Current Into the Substrate)

PARAMETER MEASUREMENT INFORMATION

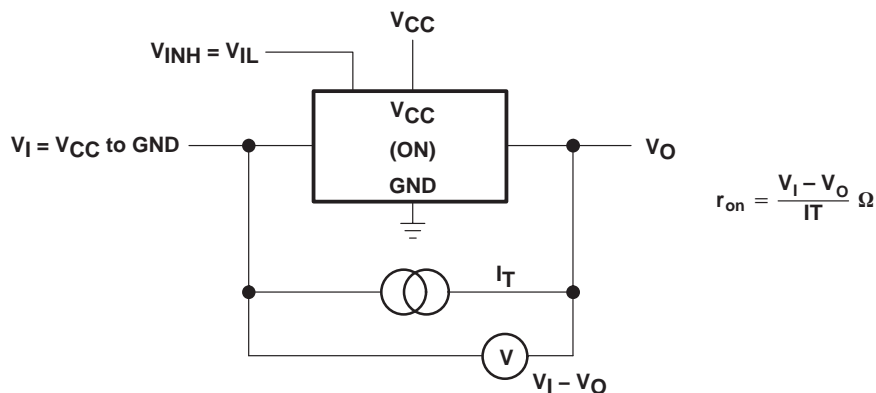

Figure 5. On-State-Resistance Test Circuit

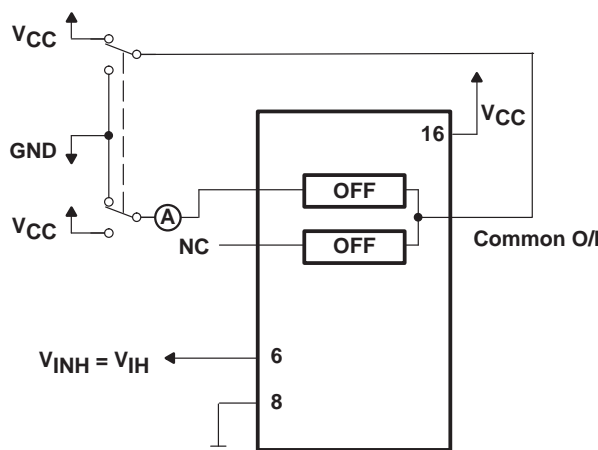

Figure 6. Maximum Off-Channel Leakage Current, Any One Channel, Test Setup

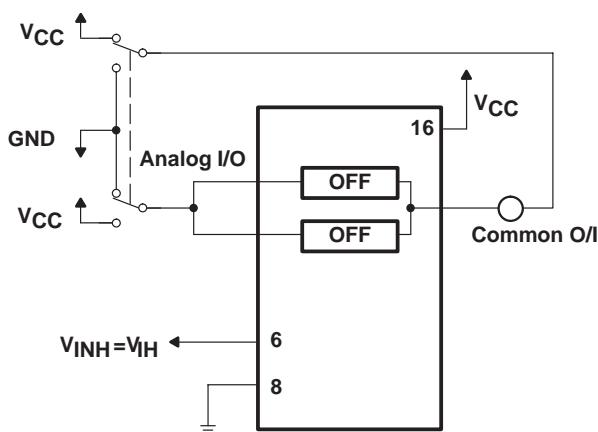

Figure 7. Maximum Off-Channel Leakage Current, Common Channel, Test Setup

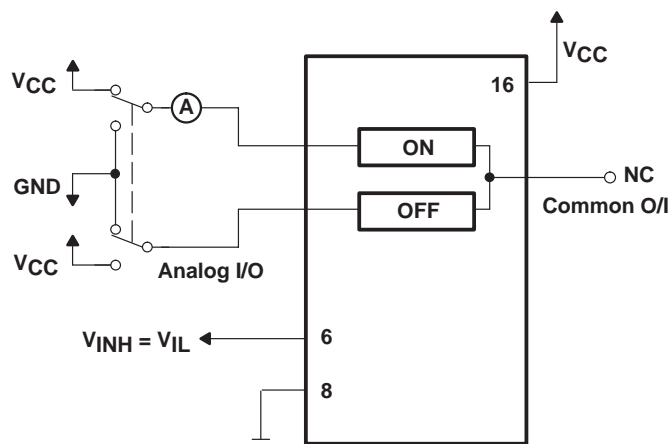

Figure 8. Maximum On-Channel Leakage Current, Channel to Channel, Test Setup

SN74HC4851-Q1
8-CHANNEL ANALOG MULTIPLEXER/DEMULTIPLEXER
WITH INJECTION-CURRENT EFFECT CONTROL

SCLS554A – JANUARY 2004 – REVISED MARCH 2004

PARAMETER MEASUREMENT INFORMATION

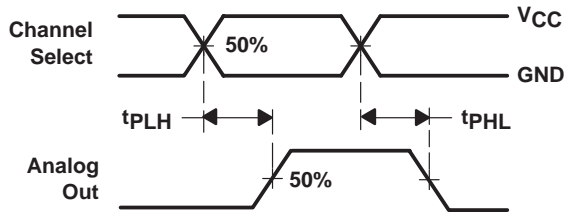
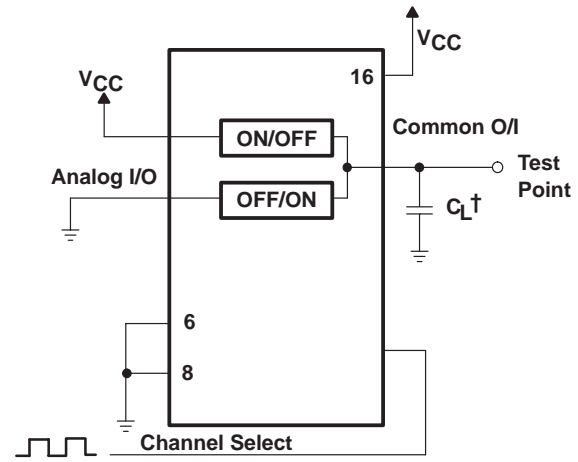

Figure 9. Propagation Delays, Channel Select to Analog Out



† Includes all probe and jig capacitance

Figure 10. Propagation-Delay Test Setup, Channel Select to Analog Out

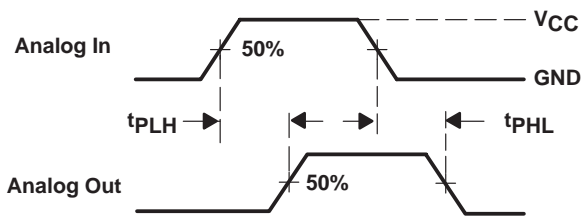
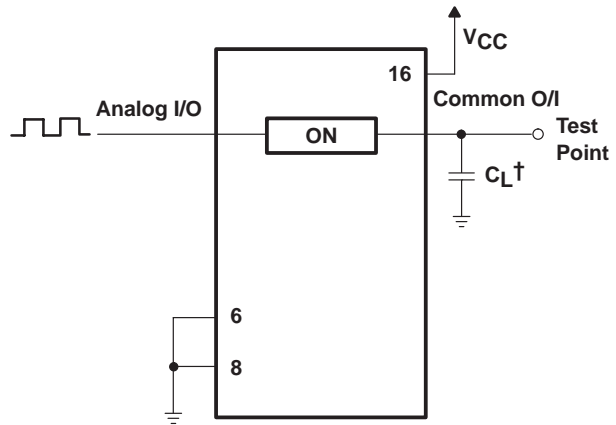

Figure 11. Propagation Delays, Analog In to Analog Out



† Includes all probe and jig capacitance

Figure 12. Propagation-Delay Test Setup, Analog In to Analog Out

SN74HC4851-Q1
8-CHANNEL ANALOG MULTIPLEXER/DEMULTIPLEXER
WITH INJECTION-CURRENT EFFECT CONTROL

SCLS554A – JANUARY 2004 – REVISED MARCH 2004

PARAMETER MEASUREMENT INFORMATION

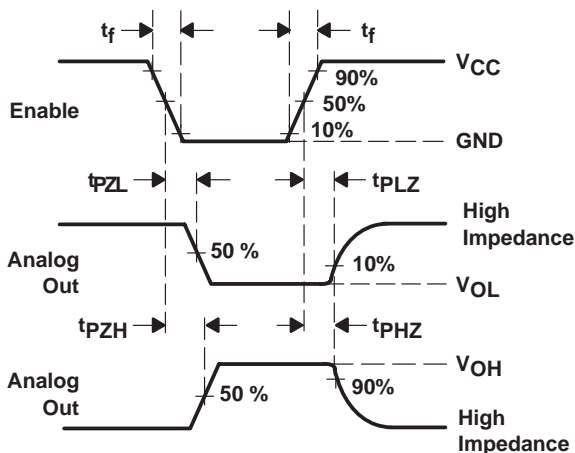

Figure 13. Propagation Delays, Enable to Analog Out

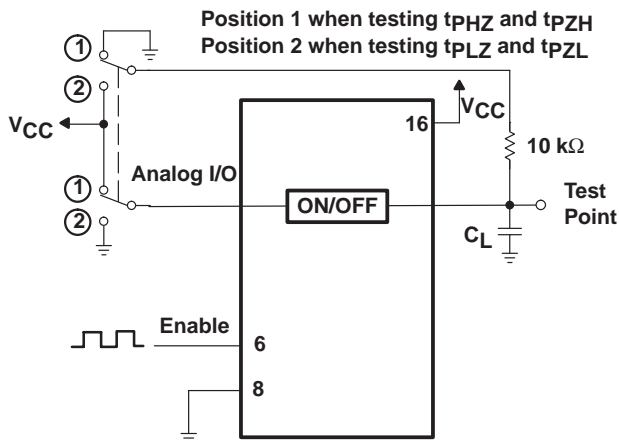

Figure 14. Propagation-Delay Test Setup, Enable to Analog Out

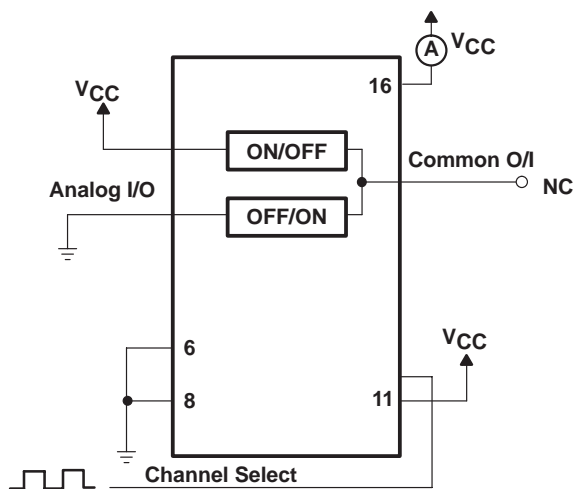

Figure 15. Power-Dissipation Capacitance Test Setup

D (R-PDSO-G16)

PLASTIC SMALL-OUTLINE PACKAGE



- NOTES:
- A. All linear dimensions are in inches (millimeters).
 - B. This drawing is subject to change without notice.
 - C. Body dimensions do not include mold flash or protrusion not to exceed 0.006 (0,15).
 - D. Falls within JEDEC MS-012 variation AC.

PW (R-PDSO-G**)

PLASTIC SMALL-OUTLINE PACKAGE

14 PINS SHOWN



4040064/F 01/97

- NOTES: A. All linear dimensions are in millimeters.
 B. This drawing is subject to change without notice.
 C. Body dimensions do not include mold flash or protrusion not to exceed 0,15.
 D. Falls within JEDEC MO-153

IMPORTANT NOTICE

Texas Instruments Incorporated and its subsidiaries (TI) reserve the right to make corrections, modifications, enhancements, improvements, and other changes to its products and services at any time and to discontinue any product or service without notice. Customers should obtain the latest relevant information before placing orders and should verify that such information is current and complete. All products are sold subject to TI's terms and conditions of sale supplied at the time of order acknowledgment.

TI warrants performance of its hardware products to the specifications applicable at the time of sale in accordance with TI's standard warranty. Testing and other quality control techniques are used to the extent TI deems necessary to support this warranty. Except where mandated by government requirements, testing of all parameters of each product is not necessarily performed.

TI assumes no liability for applications assistance or customer product design. Customers are responsible for their products and applications using TI components. To minimize the risks associated with customer products and applications, customers should provide adequate design and operating safeguards.

TI does not warrant or represent that any license, either express or implied, is granted under any TI patent right, copyright, mask work right, or other TI intellectual property right relating to any combination, machine, or process in which TI products or services are used. Information published by TI regarding third-party products or services does not constitute a license from TI to use such products or services or a warranty or endorsement thereof. Use of such information may require a license from a third party under the patents or other intellectual property of the third party, or a license from TI under the patents or other intellectual property of TI.

Reproduction of information in TI data books or data sheets is permissible only if reproduction is without alteration and is accompanied by all associated warranties, conditions, limitations, and notices. Reproduction of this information with alteration is an unfair and deceptive business practice. TI is not responsible or liable for such altered documentation.

Resale of TI products or services with statements different from or beyond the parameters stated by TI for that product or service voids all express and any implied warranties for the associated TI product or service and is an unfair and deceptive business practice. TI is not responsible or liable for any such statements.

Following are URLs where you can obtain information on other Texas Instruments products and application solutions:

Products		Applications	
Amplifiers	amplifier.ti.com	Audio	www.ti.com/audio
Data Converters	dataconverter.ti.com	Automotive	www.ti.com/automotive
DSP	dsp.ti.com	Broadband	www.ti.com/broadband
Interface	interface.ti.com	Digital Control	www.ti.com/digitalcontrol
Logic	logic.ti.com	Military	www.ti.com/military
Power Mgmt	power.ti.com	Optical Networking	www.ti.com/opticalnetwork
Microcontrollers	microcontroller.ti.com	Security	www.ti.com/security
		Telephony	www.ti.com/telephony
		Video & Imaging	www.ti.com/video
		Wireless	www.ti.com/wireless

Mailing Address: Texas Instruments
Post Office Box 655303 Dallas, Texas 75265