

SN54LV594A, SN74LV594A 8-BIT SHIFT REGISTERS WITH OUTPUT REGISTERS

SCLS413H – APRIL 1998 – REVISED DECEMBER 2004

- 2-V to 5.5-V V_{CC} Operation
- Max t_{pd} of 6.5 ns at 5 V
- Typical V_{OLP} (Output Ground Bounce) <math><0.8\text{ V}</math> at $V_{CC} = 3.3\text{ V}$, $T_A = 25^\circ\text{C}$
- Typical V_{OHV} (Output V_{OH} Undershoot) >math>>2.3\text{ V}</math> at $V_{CC} = 3.3\text{ V}$, $T_A = 25^\circ\text{C}$
- Support Mixed-Mode Voltage Operation on All Ports
- 8-Bit Serial-In, Parallel-Out Shift Registers With Storage
- Independent Direct Overriding Clears on Shift and Storage Registers
- Independent Clocks for Shift and Storage Registers
- Latch-Up Performance Exceeds 100 mA Per JESD 78, Class II
- ESD Protection Exceeds JESD 22
 - 2000-V Human-Body Model (A114-A)
 - 200-V Machine Model (A115-A)
 - 1000-V Charged-Device Model (C101)

description/ordering information

The 'LV594A devices are 8-bit shift registers designed for 2-V to 5.5-V V_{CC} operation.

These devices contain an 8-bit serial-in, parallel-out shift register that feeds an 8-bit D-type storage register. Separate clocks (RCLK, SRCLK) and direct overriding clear ($\overline{\text{RCLR}}$, $\overline{\text{SRCLR}}$) inputs are provided on the shift and storage registers. A serial output (Q_H) is provided for cascading purposes.

SN54LV594A . . . J OR W PACKAGE
SN74LV594A . . . D, DB, NS, OR PW PACKAGE
(TOP VIEW)

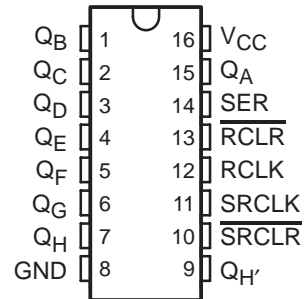

SN54LV594A . . . FK PACKAGE
(TOP VIEW)

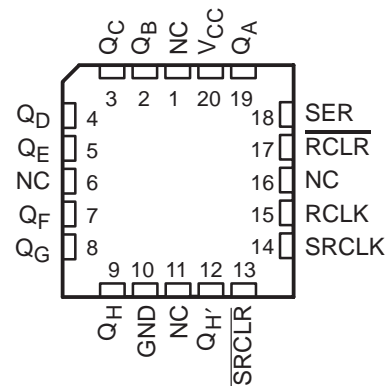

NC – No internal connection

ORDERING INFORMATION

T_A	PACKAGE†		ORDERABLE PART NUMBER	TOP-SIDE MARKING
–40°C to 85°C	SOIC – D	Tube of 40	SN74LV594AD	LV594A
		Reel of 2500	SN74LV594ADR	
	SOP – NS	Reel of 2000	SN74LV594ANSR	74LV594A
	SSOP – DB	Reel of 2000	SN74LV594ADBR	LV594A
	TSSOP – PW	Tube of 90	SN74LV594APW	LV594A
Reel of 2000		SN74LV594APWR		
Reel of 250		SN74LV594APWT		
–55°C to 125°C	CDIP – J	Tube of 25	SNJ54LV594AJ	SNJ54LV594AJ
	CFP – W	Tube of 150	SNJ54LV594AW	SNJ54LV594AW
	LCCC – FK	Tube of 55	SNJ54LV594AFK	SNJ54LV594AFK

† Package drawings, standard packing quantities, thermal data, symbolization, and PCB design guidelines are available at www.ti.com/sc/package.



Please be aware that an important notice concerning availability, standard warranty, and use in critical applications of Texas Instruments semiconductor products and disclaimers thereto appears at the end of this data sheet.

UNLESS OTHERWISE NOTED this document contains PRODUCTION DATA information current as of publication date. Products conform to specifications per the terms of Texas Instruments standard warranty. Production processing does not necessarily include testing of all parameters.

 **TEXAS
INSTRUMENTS**

POST OFFICE BOX 655303 • DALLAS, TEXAS 75265

Copyright © 2004, Texas Instruments Incorporated

SN54LV594A, SN74LV594A
8-BIT SHIFT REGISTERS
WITH OUTPUT REGISTERS

SCLS413H – APRIL 1998 – REVISED DECEMBER 2004

description/ordering information (continued)

The shift-register (SRCLK) and storage-register (RCLK) clocks are positive-edge triggered. If the clocks are tied together, the shift register always is one clock pulse ahead of the storage register.

FUNCTION TABLE

INPUTS					FUNCTION
SER	SRCLK	$\overline{\text{SRCLR}}$	RCLK	$\overline{\text{RCLR}}$	
X	X	L	X	X	Shift register is cleared.
L	↑	H	X	X	First stage of shift register goes low. Other stages store the data of previous stage, respectively.
H	↑	H	X	X	First stage of shift register goes high. Other stages store the data of previous stage, respectively.
L	↓	H	X	X	Shift register state is not changed.
X	X	X	X	L	Storage register is cleared.
X	X	X	↑	H	Shift register data is stored in the storage register.
X	X	X	↓	H	Storage register state is not changed.



SN54LV594A, SN74LV594A 8-BIT SHIFT REGISTERS WITH OUTPUT REGISTERS

SCLS413H – APRIL 1998 – REVISED DECEMBER 2004

logic diagram (positive logic)

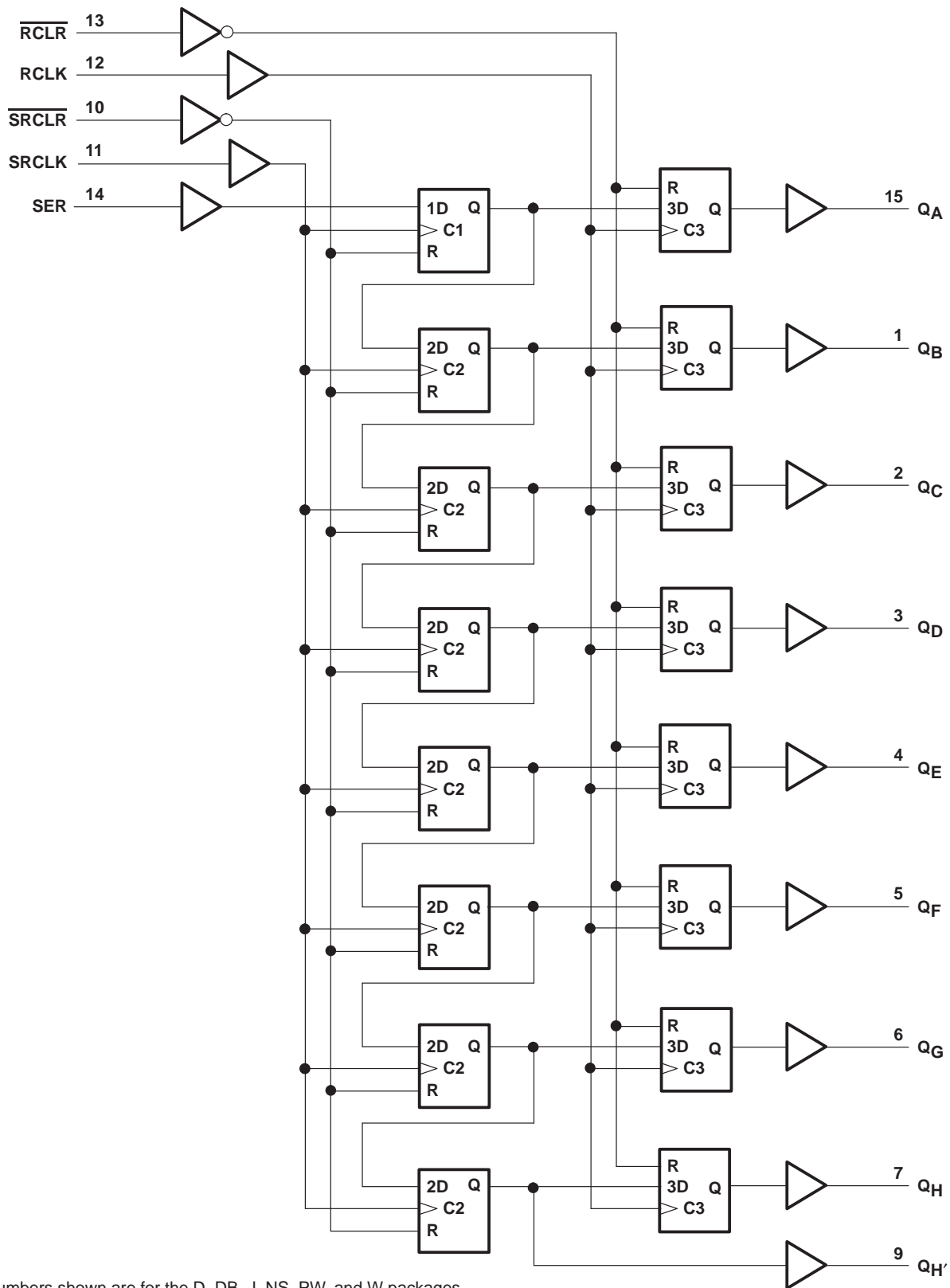

Pin numbers shown are for the D, DB, J, NS, PW, and W packages.



SN54LV594A, SN74LV594A 8-BIT SHIFT REGISTERS WITH OUTPUT REGISTERS

SCLS413H – APRIL 1998 – REVISED DECEMBER 2004

timing diagram

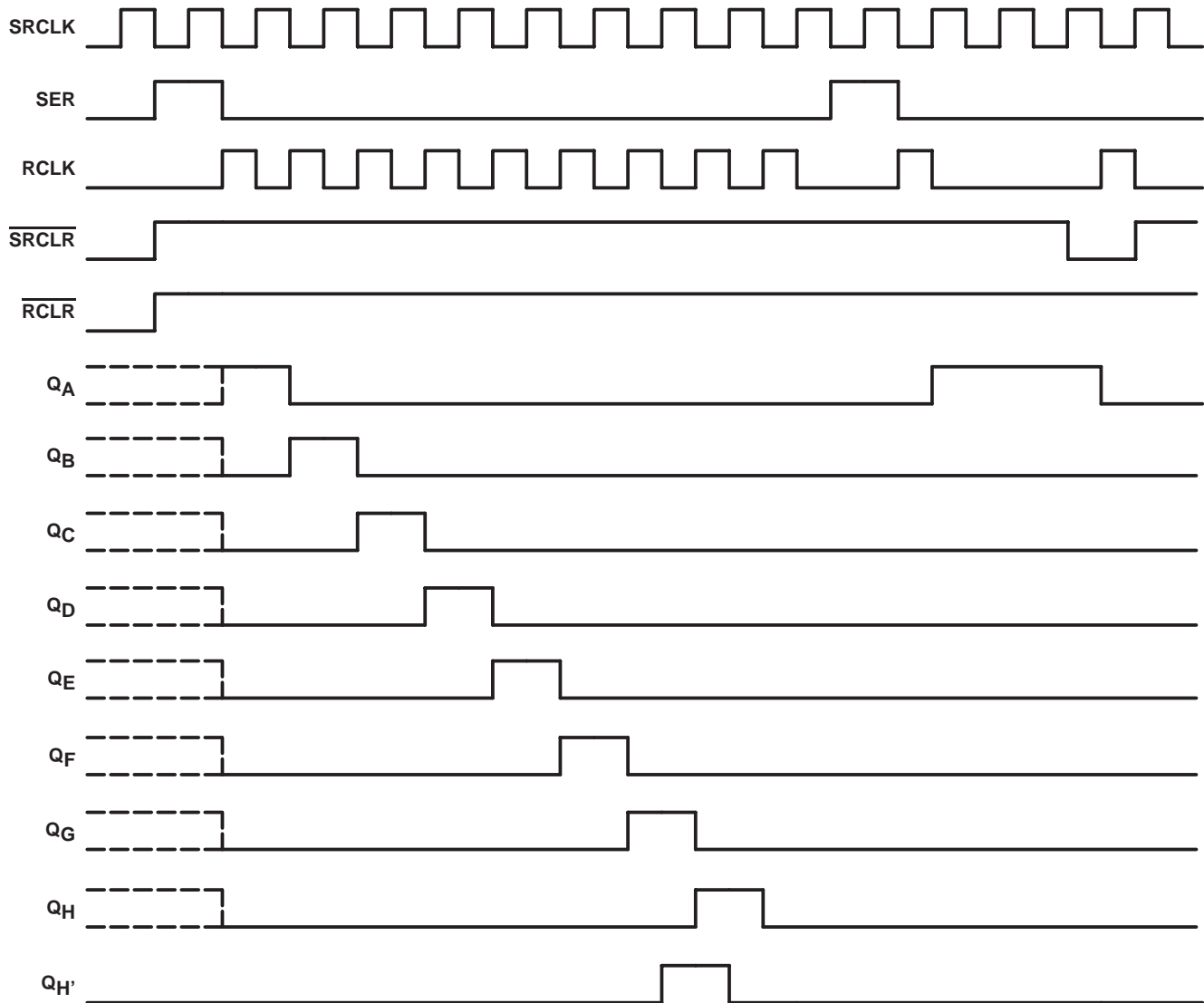

SN54LV594A, SN74LV594A
8-BIT SHIFT REGISTERS
WITH OUTPUT REGISTERS

SCLS413H – APRIL 1998 – REVISED DECEMBER 2004

absolute maximum ratings over operating free-air temperature range (unless otherwise noted)†

Supply voltage range, V_{CC}	-0.5 V to 7 V
Input voltage range, V_I (see Note 1)	-0.5 V to 7 V
Voltage range applied to any output in the high-impedance or power-off state, V_O (see Note 1)	-0.5 V to 7 V
Output voltage range, V_O (see Notes 1 and 2)	-0.5 V to $V_{CC} + 0.5$ V
Input clamp current, I_{IK} ($V_I < 0$)	-20 mA
Output clamp current, I_{OK} ($V_O < 0$)	-50 mA
Continuous output current, I_O ($V_O = 0$ to V_{CC})	± 25 mA
Continuous current through V_{CC} or GND	± 50 mA
Package thermal impedance, θ_{JA} (see Note 3): D package	73°C/W
DB package	82°C/W
NS package	64°C/W
PW package	108°C/W
Storage temperature range, T_{stg}	-65°C to 150°C

† Stresses beyond those listed under “absolute maximum ratings” may cause permanent damage to the device. These are stress ratings only, and functional operation of the device at these or any other conditions beyond those indicated under “recommended operating conditions” is not implied. Exposure to absolute-maximum-rated conditions for extended periods may affect device reliability.

- NOTES: 1. The input and output voltage ratings may be exceeded if the input and output current ratings are observed.
2. This value is limited to 5.5 V maximum.
3. The package thermal impedance is calculated in accordance with JESD 51-7.



SN54LV594A, SN74LV594A 8-BIT SHIFT REGISTERS WITH OUTPUT REGISTERS

SCLS413H – APRIL 1998 – REVISED DECEMBER 2004

recommended operating conditions (see Note 4)

		SN54LV594A		SN74LV594A		UNIT
		MIN	MAX	MIN	MAX	
V_{CC}	Supply voltage	2	5.5	2	5.5	V
V_{IH}	High-level input voltage	$V_{CC} = 2\text{ V}$	1.5	1.5		V
		$V_{CC} = 2.3\text{ V to }2.7\text{ V}$	$V_{CC} \times 0.7$	$V_{CC} \times 0.7$		
		$V_{CC} = 3\text{ V to }3.6\text{ V}$	$V_{CC} \times 0.7$	$V_{CC} \times 0.7$		
		$V_{CC} = 4.5\text{ V to }5.5\text{ V}$	$V_{CC} \times 0.7$	$V_{CC} \times 0.7$		
V_{IL}	Low-level input voltage	$V_{CC} = 2\text{ V}$		0.5	0.5	V
		$V_{CC} = 2.3\text{ V to }2.7\text{ V}$		$V_{CC} \times 0.3$	$V_{CC} \times 0.3$	
		$V_{CC} = 3\text{ V to }3.6\text{ V}$		$V_{CC} \times 0.3$	$V_{CC} \times 0.3$	
		$V_{CC} = 4.5\text{ V to }5.5\text{ V}$		$V_{CC} \times 0.3$	$V_{CC} \times 0.3$	
V_I	Input voltage	0	5.5	0	5.5	V
V_O	Output voltage	0	V_{CC}	0	V_{CC}	V
I_{OH}	High-level output current	$V_{CC} = 2\text{ V}$		-50	-50	μA
		$V_{CC} = 2.3\text{ V to }2.7\text{ V}$		-2	-2	mA
		$V_{CC} = 3\text{ V to }3.6\text{ V}$		-6	-6	
		$V_{CC} = 4.5\text{ V to }5.5\text{ V}$		-12	-12	
I_{OL}	Low-level output current	$V_{CC} = 2\text{ V}$		50	50	μA
		$V_{CC} = 2.3\text{ V to }2.7\text{ V}$		2	2	mA
		$V_{CC} = 3\text{ V to }3.6\text{ V}$		6	6	
		$V_{CC} = 4.5\text{ V to }5.5\text{ V}$		12	12	
$\Delta t/\Delta v$	Input transition rise or fall rate	$V_{CC} = 2.3\text{ V to }2.7\text{ V}$		200	200	ns/V
		$V_{CC} = 3\text{ V to }3.6\text{ V}$		100	100	
		$V_{CC} = 4.5\text{ V to }5.5\text{ V}$		20	20	
T_A	Operating free-air temperature	-55	125	-40	85	$^{\circ}\text{C}$

NOTE 4: All unused inputs of the device must be held at V_{CC} or GND to ensure proper device operation. Refer to the TI application report, *Implications of Slow or Floating CMOS Inputs*, literature number SCBA004.

electrical characteristics over recommended operating free-air temperature range (unless otherwise noted)

PARAMETER	TEST CONDITIONS	V_{CC}	SN54LV594A			SN74LV594A			UNIT
			MIN	TYP	MAX	MIN	TYP	MAX	
V_{OH}	$I_{OH} = -50\ \mu\text{A}$	2 V to 5.5 V	$V_{CC}-0.1$			$V_{CC}-0.1$			V
	$I_{OH} = -2\ \text{mA}$	2.3 V	2			2			
	$I_{OH} = -6\ \text{mA}$	3 V	2.48			2.48			
	$I_{OH} = -12\ \text{mA}$	4.5 V	3.8			3.8			
V_{OL}	$I_{OL} = 50\ \mu\text{A}$	2 V to 5.5 V				0.1			V
	$I_{OL} = 2\ \text{mA}$	2.3 V				0.4			
	$I_{OL} = 6\ \text{mA}$	3 V				0.44			
	$I_{OL} = 12\ \text{mA}$	4.5 V				0.55			
I_I	$V_I = 5.5\text{ V or GND}$	0 to 5.5 V				± 1			μA
I_{CC}	$V_I = V_{CC}\text{ or GND, } I_O = 0$	5.5 V				20			μA
I_{off}	$V_I\text{ or }V_O = 0\text{ to }5.5\text{ V}$	0				5			μA
C_i	$V_I = V_{CC}\text{ or GND}$	3.3 V	3.5			3.5			pF

PRODUCT PREVIEW information concerns products in the formative or design phase of development. Characteristic data and other specifications are design goals. Texas Instruments reserves the right to change or discontinue these products without notice.



SN54LV594A, SN74LV594A 8-BIT SHIFT REGISTERS WITH OUTPUT REGISTERS

SCLS413H – APRIL 1998 – REVISED DECEMBER 2004

timing requirements over recommended operating free-air temperature range, $V_{CC} = 2.5\text{ V} \pm 0.2\text{ V}$ (unless otherwise noted) (see Figure 1)

		$T_A = 25^\circ\text{C}$		SN54LV594A		SN74LV594A		UNIT
		MIN	MAX	MIN	MAX	MIN	MAX	
t_w	Pulse duration	RCLK or SRCLK high or low		7	7.5	7.5		ns
		$\overline{\text{RCLR}}$ or $\overline{\text{SRCLR}}$ low		6	6.5	6.5		
t_{su}	Setup time	SER before SRCLK \uparrow		5.5	5.5	5.5		ns
		SRCLK \uparrow before RCLK \uparrow \dagger		8	9	9		
		$\overline{\text{SRCLR}}$ low before RCLK \uparrow		8.5	9.5	9.5		
		$\overline{\text{SRCLR}}$ high (inactive) before SRCLK \uparrow		6	6.8	6.8		
		$\overline{\text{RCLR}}$ high (inactive) before RCLK \uparrow		6.7	7.6	7.6		
t_h	Hold time	SER after SRCLK \uparrow		1.5	1.5	1.5		ns

\dagger This setup time allows the storage register to receive stable data from the shift register. The clocks can be tied together, in which case the shift register is one clock pulse ahead of the storage register.

timing requirements over recommended operating free-air temperature range, $V_{CC} = 3.3\text{ V} \pm 0.3\text{ V}$ (unless otherwise noted) (see Figure 1)

		$T_A = 25^\circ\text{C}$		SN54LV594A		SN74LV594A		UNIT
		MIN	MAX	MIN	MAX	MIN	MAX	
t_w	Pulse duration	RCLK or SRCLK high or low		5.5	5.5	5.5		ns
		$\overline{\text{RCLR}}$ or $\overline{\text{SRCLR}}$ low		5	5	5		
t_{su}	Setup time	SER before SRCLK \uparrow		3.5	3.5	3.5		ns
		SRCLK \uparrow before RCLK \uparrow \dagger		8	8.5	8.5		
		$\overline{\text{SRCLR}}$ low before RCLK \uparrow		8	9	9		
		$\overline{\text{SRCLR}}$ high (inactive) before SRCLK \uparrow		4.2	4.8	4.8		
		$\overline{\text{RCLR}}$ high (inactive) before RCLK \uparrow		4.6	5.3	5.3		
t_h	Hold time	SER after SRCLK \uparrow		1.5	1.5	1.5		ns

\dagger This setup time allows the storage register to receive stable data from the shift register. The clocks can be tied together, in which case the shift register is one clock pulse ahead of the storage register.

timing requirements over recommended operating free-air temperature range, $V_{CC} = 5\text{ V} \pm 0.5\text{ V}$ (unless otherwise noted) (see Figure 1)

		$T_A = 25^\circ\text{C}$		SN54LV594A		SN74LV594A		UNIT
		MIN	MAX	MIN	MAX	MIN	MAX	
t_w	Pulse duration	RCLK or SRCLK high or low		5	5	5		ns
		$\overline{\text{RCLR}}$ or $\overline{\text{SRCLR}}$ low		5.2	5.2	5.2		
t_{su}	Setup time	SER before SRCLK \uparrow		3	3	3		ns
		SRCLK \uparrow before RCLK \uparrow \dagger		5	5	5		
		$\overline{\text{SRCLR}}$ low before RCLK \uparrow		5	5	5		
		$\overline{\text{SRCLR}}$ high (inactive) before SRCLK \uparrow		2.9	3.3	3.3		
		$\overline{\text{RCLR}}$ high (inactive) before RCLK \uparrow		3.2	3.7	3.7		
t_h	Hold time	SER after SRCLK \uparrow		2	2	2		ns

\dagger This setup time allows the storage register to receive stable data from the shift register. The clocks can be tied together, in which case the shift register is one clock pulse ahead of the storage register.

PRODUCT PREVIEW information concerns products in the formative or design phase of development. Characteristic data and other specifications are design goals. Texas Instruments reserves the right to change or discontinue these products without notice.



POST OFFICE BOX 655303 • DALLAS, TEXAS 75265

SN54LV594A, SN74LV594A 8-BIT SHIFT REGISTERS WITH OUTPUT REGISTERS

SCLS413H – APRIL 1998 – REVISED DECEMBER 2004

switching characteristics over recommended operating free-air temperature range, $V_{CC} = 2.5 V \pm 0.2 V$ (unless otherwise noted) (see Figure 1)

PARAMETER	FROM (INPUT)	TO (OUTPUT)	LOAD CAPACITANCE	$T_A = 25^\circ C$			SN54LV594A		SN74LV594A		UNIT		
				MIN	TYP	MAX	MIN	MAX	MIN	MAX			
f_{max}			$C_L = 15 \text{ pF}$	65*	80*		45*		45		MHz		
			$C_L = 50 \text{ pF}$	60	70		40		40				
t_{PLH}	RCLK	Q_A-Q_H	$C_L = 15 \text{ pF}$		6.4*	10.6*	1*	11.1*	1	11.1	ns		
t_{PHL}					6.3*	10.4*	1*	11.1*	1	11.1			
t_{PLH}	SRCLK	Q_H'			7.4*	12.1*	1*	12.8*	1	12.8			
t_{PHL}					7.2*	11.6*	1*	12.8*	1	12.8			
t_{PHL}	$\overline{\text{RCLR}}$	Q_A-Q_H			7.9*	12.7*	1*	13.6*	1	13.6			
	$\overline{\text{SRCLR}}$	Q_H'			7.4*	11.9*	1*	13.1*	1	13.1			
t_{PLH}	RCLK	Q_A-Q_H		$C_L = 50 \text{ pF}$		9.5	14.1	1	14.6	1		14.6	ns
t_{PHL}						10.8	15.5	1	17.2	1		17.2	
t_{PLH}	SRCLK	Q_H'			10.6	15.7	1	16.5	1	16.5			
t_{PHL}					11.3	16.1	1	18.6	1	18.6			
t_{PHL}	$\overline{\text{RCLR}}$	Q_A-Q_H			12.1	17.4	1	19	1	19			
	$\overline{\text{SRCLR}}$	Q_H'			11.6	16.5	1	18.6	1	18.6			

* On products compliant to MIL-PRF-38535, this parameter is not production tested.

switching characteristics over recommended operating free-air temperature range, $V_{CC} = 3.3 V \pm 0.3 V$ (unless otherwise noted) (see Figure 1)

PARAMETER	FROM (INPUT)	TO (OUTPUT)	LOAD CAPACITANCE	$T_A = 25^\circ C$			SN54LV594A		SN74LV594A		UNIT		
				MIN	TYP	MAX	MIN	MAX	MIN	MAX			
f_{max}			$C_L = 15 \text{ pF}$	80*	120*		70*		70		MHz		
			$C_L = 50 \text{ pF}$	55	105		50		50				
t_{PLH}	RCLK	Q_A-Q_H	$C_L = 15 \text{ pF}$		4.6*	8*	1*	8.5*	1	8.5	ns		
t_{PHL}					4.9*	8.2*	1*	8.8*	1	8.8			
t_{PLH}	SRCLK	Q_H'			5.4*	9.1*	1*	9.7*	1	9.7			
t_{PHL}					5.5*	9.2*	1*	9.9*	1	9.9			
t_{PHL}	$\overline{\text{RCLR}}$	Q_A-Q_H			6*	9.8*	1*	10.6*	1	10.6			
	$\overline{\text{SRCLR}}$	Q_H'			5.6*	9.2*	1*	10*	1	10			
t_{PLH}	RCLK	Q_A-Q_H		$C_L = 50 \text{ pF}$		6.9	10.5	1	11.1	1		11.1	ns
t_{PHL}						8.1	11.9	1	13.1	1		13.1	
t_{PLH}	SRCLK	Q_H'			7.7	11.7	1	12.4	1	12.4			
t_{PHL}					8.4	12.5	1	13.9	1	13.9			
t_{PHL}	$\overline{\text{RCLR}}$	Q_A-Q_H			9.1	13.1	1	14.4	1	14.4			
	$\overline{\text{SRCLR}}$	Q_H'			8.5	12.4	1	14	1	14			

* On products compliant to MIL-PRF-38535, this parameter is not production tested.

PRODUCT PREVIEW information concerns products in the formative or design phase of development. Characteristic data and other specifications are design goals. Texas Instruments reserves the right to change or discontinue these products without notice.



SN54LV594A, SN74LV594A 8-BIT SHIFT REGISTERS WITH OUTPUT REGISTERS

SCLS413H – APRIL 1998 – REVISED DECEMBER 2004

switching characteristics over recommended operating free-air temperature range, $V_{CC} = 5\text{ V} \pm 0.5\text{ V}$ (unless otherwise noted) (see Figure 1)

PARAMETER	FROM (INPUT)	TO (OUTPUT)	LOAD CAPACITANCE	$T_A = 25^\circ\text{C}$			SN54LV594A		SN74LV594A		UNIT		
				MIN	TYP	MAX	MIN	MAX	MIN	MAX			
f_{max}			$C_L = 15\text{ pF}$	135*	170*		115*		115		MHz		
			$C_L = 50\text{ pF}$	120	140		95		95				
t_{PLH}	RCLK	Q_A-Q_H	$C_L = 15\text{ pF}$		3.3*	6.2*	1*	6.5*	1	6.5	ns		
t_{PHL}					3.7*	6.5*	1*	6.9*	1	6.9			
t_{PLH}	SRCLK	$Q_{H'}$			3.7*	6.8*	1*	7.2*	1	7.2			
t_{PHL}					4.1*	7.2*	1*	7.6*	1	7.6			
t_{PHL}	$\overline{\text{RCLR}}$	Q_A-Q_H			4.5*	7.6*	1*	8.2*	1	8.2			
	$\overline{\text{SRCLR}}$	$Q_{H'}$			4.1*	7.1*	1*	7.6*	1	7.6			
t_{PLH}	RCLK	Q_A-Q_H		$C_L = 50\text{ pF}$		4.9	7.8	1	8.3	1		8.3	ns
t_{PHL}						5.8	8.9	1	9.7	1		9.7	
t_{PLH}	SRCLK	$Q_{H'}$			5.5	8.6	1	9.1	1	9.1			
t_{PHL}					6	9.2	1	10.1	1	10.1			
t_{PHL}	$\overline{\text{RCLR}}$	Q_A-Q_H			6.6	10	1	10.7	1	10.7			
	$\overline{\text{SRCLR}}$	$Q_{H'}$			6	9.2	1	10.1	1	10.1			

* On products compliant to MIL-PRF-38535, this parameter is not production tested.

noise characteristics, $V_{CC} = 3.3\text{ V}$, $C_L = 50\text{ pF}$, $T_A = 25^\circ\text{C}$ (see Note 5)

PARAMETER		SN74LV594A			UNIT
		MIN	TYP	MAX	
$V_{OL(P)}$	Quiet output, maximum dynamic V_{OL}	0.5	0.8		V
$V_{OL(V)}$	Quiet output, minimum dynamic V_{OL}	-0.1	-0.8		V
$V_{OH(V)}$	Quiet output, minimum dynamic V_{OH}	2.8			V
$V_{IH(D)}$	High-level dynamic input voltage	2.31			V
$V_{IL(D)}$	Low-level dynamic input voltage		0.99		V

NOTE 5: Characteristics are for surface-mount packages only.

operating characteristics, $T_A = 25^\circ\text{C}$

PARAMETER		TEST CONDITIONS	V_{CC}	TYP	UNIT
C_{pd}	Power dissipation capacitance	$f = 10\text{ MHz}$	3.3 V	93	pF
			5 V	112	

PRODUCT PREVIEW information concerns products in the formative or design phase of development. Characteristic data and other specifications are design goals. Texas Instruments reserves the right to change or discontinue these products without notice.



POST OFFICE BOX 655303 • DALLAS, TEXAS 75265

SN54LV594A, SN74LV594A 8-BIT SHIFT REGISTERS WITH OUTPUT REGISTERS

SCLS413H – APRIL 1998 – REVISED DECEMBER 2004

PARAMETER MEASUREMENT INFORMATION

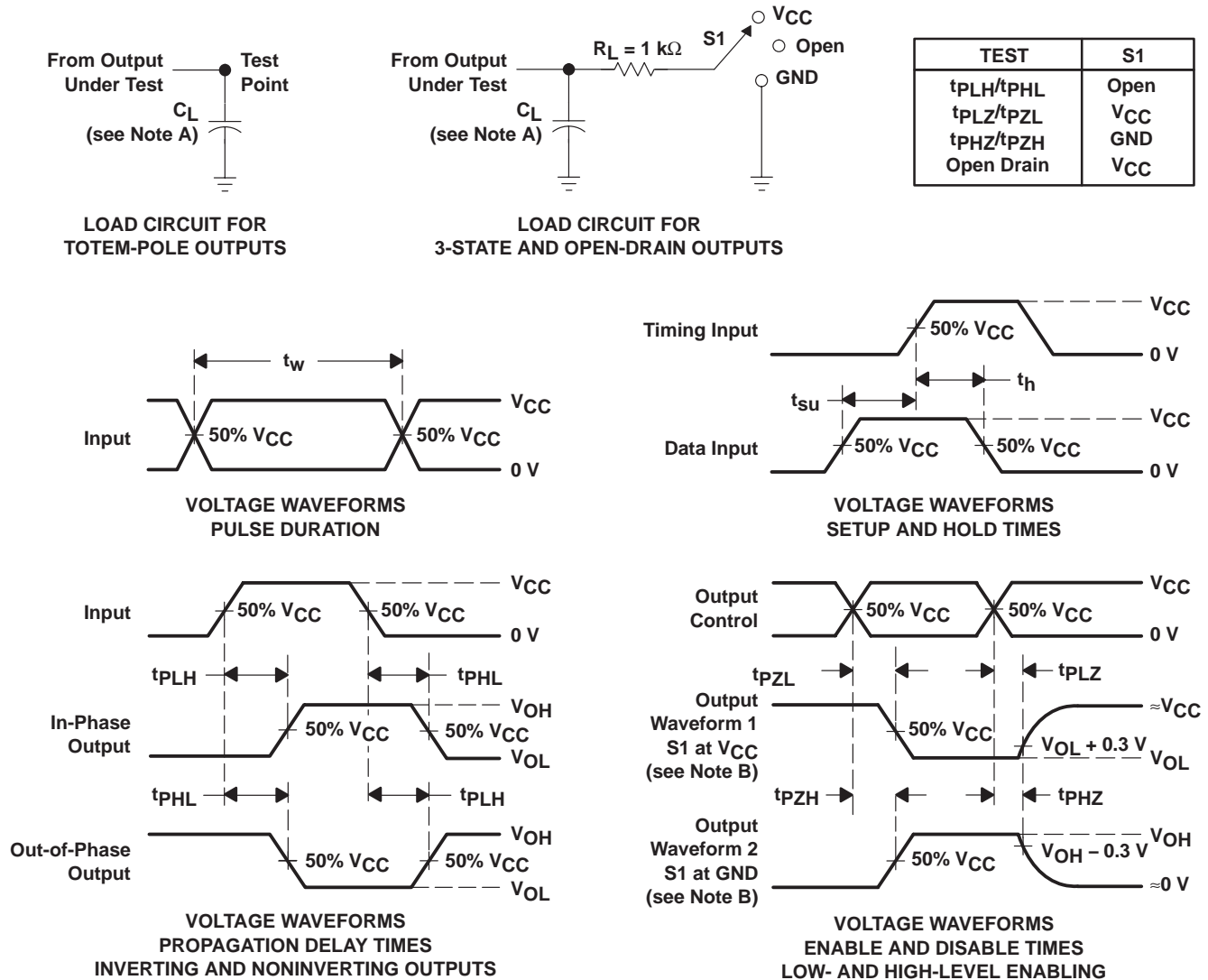

- NOTES:
- A. C_L includes probe and jig capacitance.
 - B. Waveform 1 is for an output with internal conditions such that the output is low, except when disabled by the output control. Waveform 2 is for an output with internal conditions such that the output is high, except when disabled by the output control.
 - C. All input pulses are supplied by generators having the following characteristics: PRR ≤ 1 MHz, Z_O = 50 Ω, t_r ≤ 3 ns, t_f ≤ 3 ns.
 - D. The outputs are measured one at a time, with one input transition per measurement.
 - E. t_{PLZ} and t_{PHZ} are the same as t_{dis}.
 - F. t_{PZL} and t_{PZH} are the same as t_{en}.
 - G. t_{PHL} and t_{PLH} are the same as t_{pd}.
 - H. All parameters and waveforms are not applicable to all devices.

Figure 1. Load Circuit and Voltage Waveforms

PACKAGING INFORMATION

Orderable Device	Status ⁽¹⁾	Package Type	Package Drawing	Pins	Package Qty	Eco Plan ⁽²⁾	Lead/Ball Finish	MSL Peak Temp ⁽³⁾
SN74LV594AD	ACTIVE	SOIC	D	16	40	Pb-Free (RoHS)	CU NIPDAU	Level-2-260C-1 YEAR/ Level-1-235C-UNLIM
SN74LV594ADBR	ACTIVE	SSOP	DB	16	2000	Pb-Free (RoHS)	CU NIPDAU	Level-2-260C-1 YEAR/ Level-1-235C-UNLIM
SN74LV594ADR	ACTIVE	SOIC	D	16	2500	Pb-Free (RoHS)	CU NIPDAU	Level-2-260C-1 YEAR/ Level-1-235C-UNLIM
SN74LV594ANSR	ACTIVE	SO	NS	16	2000	Pb-Free (RoHS)	CU NIPDAU	Level-2-260C-1 YEAR/ Level-1-235C-UNLIM
SN74LV594APW	ACTIVE	TSSOP	PW	16	90	Pb-Free (RoHS)	CU NIPDAU	Level-1-250C-UNLIM
SN74LV594APWR	ACTIVE	TSSOP	PW	16	2000	Pb-Free (RoHS)	CU NIPDAU	Level-1-250C-UNLIM
SN74LV594APWT	ACTIVE	TSSOP	PW	16	250	Pb-Free (RoHS)	CU NIPDAU	Level-1-250C-UNLIM

⁽¹⁾ The marketing status values are defined as follows:

ACTIVE: Product device recommended for new designs.

LIFEBUY: TI has announced that the device will be discontinued, and a lifetime-buy period is in effect.

NRND: Not recommended for new designs. Device is in production to support existing customers, but TI does not recommend using this part in a new design.

PREVIEW: Device has been announced but is not in production. Samples may or may not be available.

OBSELETE: TI has discontinued the production of the device.

⁽²⁾ Eco Plan - May not be currently available - please check <http://www.ti.com/productcontent> for the latest availability information and additional product content details.

None: Not yet available Lead (Pb-Free).

Pb-Free (RoHS): TI's terms "Lead-Free" or "Pb-Free" mean semiconductor products that are compatible with the current RoHS requirements for all 6 substances, including the requirement that lead not exceed 0.1% by weight in homogeneous materials. Where designed to be soldered at high temperatures, TI Pb-Free products are suitable for use in specified lead-free processes.

Green (RoHS & no Sb/Br): TI defines "Green" to mean "Pb-Free" and in addition, uses package materials that do not contain halogens, including bromine (Br) or antimony (Sb) above 0.1% of total product weight.

⁽³⁾ MSL, Peak Temp. -- The Moisture Sensitivity Level rating according to the JEDEC industry standard classifications, and peak solder temperature.

Important Information and Disclaimer: The information provided on this page represents TI's knowledge and belief as of the date that it is provided. TI bases its knowledge and belief on information provided by third parties, and makes no representation or warranty as to the accuracy of such information. Efforts are underway to better integrate information from third parties. TI has taken and continues to take reasonable steps to provide representative and accurate information but may not have conducted destructive testing or chemical analysis on incoming materials and chemicals. TI and TI suppliers consider certain information to be proprietary, and thus CAS numbers and other limited information may not be available for release.

In no event shall TI's liability arising out of such information exceed the total purchase price of the TI part(s) at issue in this document sold by TI to Customer on an annual basis.

MECHANICAL DATA

NS (R-PDSO-G**)

PLASTIC SMALL-OUTLINE PACKAGE

14-PINS SHOWN



- NOTES:
- A. All linear dimensions are in millimeters.
 - B. This drawing is subject to change without notice.
 - C. Body dimensions do not include mold flash or protrusion, not to exceed 0,15.

DB (R-PDSO-G**)

PLASTIC SMALL-OUTLINE

28 PINS SHOWN



- NOTES: A. All linear dimensions are in millimeters.
 B. This drawing is subject to change without notice.
 C. Body dimensions do not include mold flash or protrusion not to exceed 0,15.
 D. Falls within JEDEC MO-150

PW (R-PDSO-G**)

PLASTIC SMALL-OUTLINE PACKAGE

14 PINS SHOWN



4040064/F 01/97

- NOTES: A. All linear dimensions are in millimeters.
 B. This drawing is subject to change without notice.
 C. Body dimensions do not include mold flash or protrusion not to exceed 0,15.
 D. Falls within JEDEC MO-153

IMPORTANT NOTICE

Texas Instruments Incorporated and its subsidiaries (TI) reserve the right to make corrections, modifications, enhancements, improvements, and other changes to its products and services at any time and to discontinue any product or service without notice. Customers should obtain the latest relevant information before placing orders and should verify that such information is current and complete. All products are sold subject to TI's terms and conditions of sale supplied at the time of order acknowledgment.

TI warrants performance of its hardware products to the specifications applicable at the time of sale in accordance with TI's standard warranty. Testing and other quality control techniques are used to the extent TI deems necessary to support this warranty. Except where mandated by government requirements, testing of all parameters of each product is not necessarily performed.

TI assumes no liability for applications assistance or customer product design. Customers are responsible for their products and applications using TI components. To minimize the risks associated with customer products and applications, customers should provide adequate design and operating safeguards.

TI does not warrant or represent that any license, either express or implied, is granted under any TI patent right, copyright, mask work right, or other TI intellectual property right relating to any combination, machine, or process in which TI products or services are used. Information published by TI regarding third-party products or services does not constitute a license from TI to use such products or services or a warranty or endorsement thereof. Use of such information may require a license from a third party under the patents or other intellectual property of the third party, or a license from TI under the patents or other intellectual property of TI.

Reproduction of information in TI data books or data sheets is permissible only if reproduction is without alteration and is accompanied by all associated warranties, conditions, limitations, and notices. Reproduction of this information with alteration is an unfair and deceptive business practice. TI is not responsible or liable for such altered documentation.

Resale of TI products or services with statements different from or beyond the parameters stated by TI for that product or service voids all express and any implied warranties for the associated TI product or service and is an unfair and deceptive business practice. TI is not responsible or liable for any such statements.

Following are URLs where you can obtain information on other Texas Instruments products and application solutions:

Products		Applications	
Amplifiers	amplifier.ti.com	Audio	www.ti.com/audio
Data Converters	dataconverter.ti.com	Automotive	www.ti.com/automotive
DSP	dsp.ti.com	Broadband	www.ti.com/broadband
Interface	interface.ti.com	Digital Control	www.ti.com/digitalcontrol
Logic	logic.ti.com	Military	www.ti.com/military
Power Mgmt	power.ti.com	Optical Networking	www.ti.com/opticalnetwork
Microcontrollers	microcontroller.ti.com	Security	www.ti.com/security
		Telephony	www.ti.com/telephony
		Video & Imaging	www.ti.com/video
		Wireless	www.ti.com/wireless

Mailing Address: Texas Instruments
Post Office Box 655303 Dallas, Texas 75265