

SN74SSTV32852

24-BIT TO 48-BIT REGISTERED BUFFER WITH SSTL_2 INPUTS AND OUTPUTS

SCES361C – AUGUST 2001 – REVISED FEBRUARY 2003

- Member of the Texas Instruments Widebus™ Family
- 1-to-2 Outputs Support Stacked DDR DIMMs
- Supports SSTL_2 Data Inputs
- Outputs Meet SSTL_2 Class II Specifications
- Differential Clock (CLK and $\overline{\text{CLK}}$) Inputs
- Supports LVCMOS Switching Levels on the $\overline{\text{RESET}}$ Input
- $\overline{\text{RESET}}$ Input Disables Differential Input Receivers, Resets All Registers, and Forces All Outputs Low
- Pinout Optimizes DIMM PCB Layout
- One Device Per DIMM Required
- Latch-Up Performance Exceeds 100 mA Per JESD 78, Class II
- ESD Protection Exceeds JESD 22
 - 2000-V Human-Body Model (A114-A)
 - 1000-V Charged-Device Model (C101)

description/ordering information

This 24-bit to 48-bit registered buffer is designed for 2.3-V to 2.7-V V_{CC} operation.

All inputs are SSTL_2, except the LVCMOS reset ($\overline{\text{RESET}}$) input. All outputs are SSTL_2, Class II compatible.

The SN74SSTV32852 operates from a differential clock (CLK and $\overline{\text{CLK}}$). Data are registered at the crossing of CLK going high and $\overline{\text{CLK}}$ going low.

The device supports low-power standby operation. When $\overline{\text{RESET}}$ is low, the differential input receivers are disabled, and undriven (floating) data, clock, and reference voltage (V_{REF}) inputs are allowed. In addition, when $\overline{\text{RESET}}$ is low, all registers are reset and all outputs are forced low. The LVCMOS $\overline{\text{RESET}}$ input always must be held at a valid logic high or low level.

To ensure defined outputs from the register before a stable clock has been supplied, $\overline{\text{RESET}}$ must be held in the low state during power up.

ORDERING INFORMATION

T _A	PACKAGE†		ORDERABLE PART NUMBER	TOP-SIDE MARKING
0°C to 70°C	LFBGA – GKF	Tape and reel	SN74SSTV32852GKFR	SV852

† Package drawings, standard packing quantities, thermal data, symbolization, and PCB design guidelines are available at www.ti.com/sc/package.



Please be aware that an important notice concerning availability, standard warranty, and use in critical applications of Texas Instruments semiconductor products and disclaimers thereto appears at the end of this data sheet.

Widebus is a trademark of Texas Instruments.

PRODUCTION DATA information is current as of publication date. Products conform to specifications per the terms of Texas Instruments standard warranty. Production processing does not necessarily include testing of all parameters.



POST OFFICE BOX 655303 • DALLAS, TEXAS 75265

Copyright © 2003, Texas Instruments Incorporated

SN74SSTV32852
24-BIT TO 48-BIT REGISTERED BUFFER
WITH SSTL_2 INPUTS AND OUTPUTS

SCES361C – AUGUST 2001 – REVISED FEBRUARY 2003

GKF PACKAGE
(TOP VIEW)

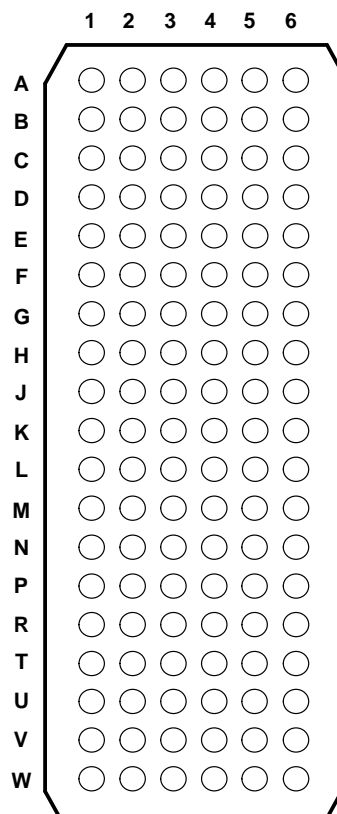

terminal assignments

	1	2	3	4	5	6
A	Q2A	Q1A	CLK	$\overline{\text{CLK}}$	Q1B	Q2B
B	Q3A	V _{DDQ}	GND	GND	V _{DDQ}	Q3B
C	Q5A	Q4A	V _{DDQ}	V _{DDQ}	Q4B	Q5B
D	Q7A	Q6A	GND	GND	Q6B	Q7B
E	Q8A	GND	V _{DDQ}	V _{DDQ}	GND	Q8B
F	Q10A	Q9A	V _{DDQ}	V _{DDQ}	Q9B	Q10B
G	Q12A	Q11A	GND	GND	Q11B	Q12B
H	Q13A	V _{CC}	V _{DDQ}	V _{DDQ}	V _{CC}	Q13B
J	Q14A	Q15A	GND	GND	Q15B	Q14B
K	Q17A	Q16A	V _{DDQ}	V _{DDQ}	Q16B	Q17B
L	Q18A	Q19A	GND	GND	Q19B	Q18B
M	Q20A	V _{DDQ}	GND	GND	V _{DDQ}	Q20B
N	Q22A	Q21A	V _{DDQ}	V _{DDQ}	Q21B	Q22B
P	Q23A	V _{DDQ}	GND	GND	V _{DDQ}	Q23B
R	Q24A	V _{CC}	$\overline{\text{RESET}}$	V _{REF}	V _{CC}	Q24B
T	D2	D1	D6	D18	D13	D14
U	D4	D3	D10	D22	D15	D16
V	D5	D7	D11	D23	D19	D17
W	D8	D9	D12	D24	D21	D20

SN74SSTV32852
24-BIT TO 48-BIT REGISTERED BUFFER
WITH SSTL_2 INPUTS AND OUTPUTS

SCES361C – AUGUST 2001 – REVISED FEBRUARY 2003

FUNCTION TABLE

INPUTS				OUTPUT
RESET	CLK	CLK	D	Q
H	↑	↓	H	H
H	↑	↓	L	L
H	L or H	L or H	X	Q ₀
L	X or floating	X or floating	X or floating	L

logic diagram (positive logic)

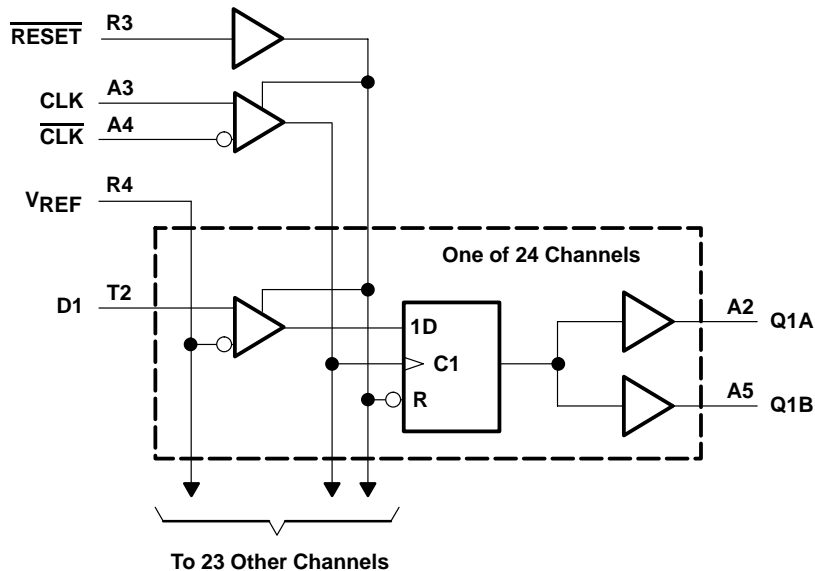

absolute maximum ratings over operating free-air temperature range (unless otherwise noted)†

Supply voltage range, V_{CC} or V_{DDQ}	–0.5 V to 3.6 V
Input voltage range, V_I (see Notes 1 and 2)	–0.5 V to $V_{CC} + 0.5$ V
Output voltage range, V_O (see Notes 1 and 2)	–0.5 V to $V_{DDQ} + 0.5$ V
Input clamp current, I_{IK} ($V_I < 0$)	–50 mA
Output clamp current, I_{OK} ($V_O < 0$ or $V_O > V_{DDQ}$)	±50 mA
Continuous output current, I_O ($V_O = 0$ to V_{DDQ})	±50 mA
Continuous current through each V_{CC} , V_{DDQ} , or GND	±100 mA
Package thermal impedance, θ_{JA} (see Note 3)	36°C/W
Storage temperature range, T_{stg}	–65°C to 150°C

† Stresses beyond those listed under “absolute maximum ratings” may cause permanent damage to the device. These are stress ratings only, and functional operation of the device at these or any other conditions beyond those indicated under “recommended operating conditions” is not implied. Exposure to absolute-maximum-rated conditions for extended periods may affect device reliability.

- NOTES: 1. The input and output negative-voltage ratings may be exceeded if the input and output clamp-current ratings are observed.
2. This value is limited to 3.6 V maximum.
3. The package thermal impedance is calculated in accordance with JESD 51-7.

SN74SSTV32852

24-BIT TO 48-BIT REGISTERED BUFFER

WITH SSTL_2 INPUTS AND OUTPUTS

SCES361C – AUGUST 2001 – REVISED FEBRUARY 2003

recommended operating conditions (see Note 4)

		MIN	NOM	MAX	UNIT
V _{CC}	Supply voltage	V _{DDQ}		2.7	V
V _{DDQ}	Output supply voltage	2.3		2.7	V
V _{REF}	Reference voltage (V _{REF} = V _{DDQ} /2)	1.15	1.25	1.35	V
V _{TT}	Termination voltage	V _{REF} -40mV	V _{REF}	V _{REF} +40mV	V
V _I	Input voltage	0		V _{CC}	V
V _{IH}	AC high-level input voltage	Data inputs	V _{REF} +310mV		V
V _{IL}	AC low-level input voltage	Data inputs		V _{REF} -310mV	V
V _{IH}	DC high-level input voltage	Data inputs	V _{REF} +150mV		V
V _{IL}	DC low-level input voltage	Data inputs		V _{REF} -150mV	V
V _{IH}	High-level input voltage	$\overline{\text{RESET}}$	1.7		V
V _{IL}	Low-level input voltage	$\overline{\text{RESET}}$		0.7	V
V _{ICR}	Common-mode input voltage range	CLK, $\overline{\text{CLK}}$	0.97	1.53	V
V _{I(PP)}	Peak-to-peak input voltage	CLK, $\overline{\text{CLK}}$	360		mV
I _{OH}	High-level output current			-20	mA
I _{OL}	Low-level output current			20	
T _A	Operating free-air temperature		0	70	°C

NOTE 4: The $\overline{\text{RESET}}$ input of the device must be held at valid logic voltage levels (not floating) to ensure proper device operation. The differential inputs must not be floating unless RESET is low. Refer to the TI application report, *Implications of Slow or Floating CMOS Inputs*, literature number SCBA004.

electrical characteristics over recommended operating free-air temperature range (unless otherwise noted)

PARAMETER		TEST CONDITIONS	V _{CC}	MIN	TYP†	MAX	UNIT					
V _{IK}		I _I = -18 mA	2.3 V			-1.2	V					
V _{OH}		I _{OH} = -100 μA	2.3 V to 2.7 V	V _{DDQ} -0.2			V					
		I _{OH} = -16 mA	2.3 V	1.95								
V _{OL}		I _{OL} = 100 μA	2.3 V to 2.7 V			0.2	V					
		I _{OL} = 16 mA	2.3 V			0.35						
I _I	All inputs	V _I = V _{CC} or GND	2.7 V			±5	μA					
I _{CC}	Static standby	$\overline{\text{RESET}}$ = GND	2.7 V			10	μA					
	Static operating	$\overline{\text{RESET}}$ = V _{CC} , V _I = V _{IH(AC)} or V _{IL(AC)}						I _O = 0	35	mA		
I _{CCD}	Dynamic operating – clock only	$\overline{\text{RESET}}$ = V _{CC} , V _I = V _{IH(AC)} or V _{IL(AC)} , CLK and $\overline{\text{CLK}}$ switching 50% duty cycle	2.7 V			46	μA/ MHz					
	Dynamic operating – per each data input	$\overline{\text{RESET}}$ = V _{CC} , V _I = V _{IH(AC)} or V _{IL(AC)} , CLK and $\overline{\text{CLK}}$ switching 50% duty cycle, One data input switching at one-half clock frequency, 50% duty cycle						I _O = 0	12	μA/ clock MHz/ D input		
r _{OH}	Output high	I _{OH} = -20 mA	2.3 V to 2.7 V	7		20	Ω					
r _{OL}	Output low	I _{OL} = 20 mA	2.3 V to 2.7 V	7		20	Ω					
C _i	Data inputs	V _I = V _{REF} ± 310 mV	2.5 V			3	3.75	4.25	pF			
	CLK, $\overline{\text{CLK}}$	V _{ICR} = 1.25 V, V _{I(PP)} = 360mV								3	3.5	4
	$\overline{\text{RESET}}$	V _I = V _{CC} or GND										

† All typical values are at V_{CC} = 2.5 V, T_A = 25°C.



SN74SSTV32852
24-BIT TO 48-BIT REGISTERED BUFFER
WITH SSTL_2 INPUTS AND OUTPUTS

SCES361C – AUGUST 2001 – REVISED FEBRUARY 2003

timing requirements over recommended operating free-air temperature range (unless otherwise noted) (see Figure 1)

			$V_{CC} = 2.5\text{ V}$ $\pm 0.2\text{ V}$		UNIT
			MIN	MAX	
f_{clock}	Clock frequency		200		MHz
t_w	Pulse duration, CLK, $\overline{\text{CLK}}$ high or low		2.5		ns
t_{act}	Differential inputs active time (see Note 5)		22		ns
t_{inact}	Differential inputs inactive time (see Note 6)		22		ns
t_{su}	Setup time	Fast slew rate (see Notes 7 and 9)	Data before CLK \uparrow , $\overline{\text{CLK}}\downarrow$		ns
		Slow slew rate (see Notes 8 and 9)			
t_h	Hold time	Fast slew rate (see Notes 7 and 9)	Data after CLK \uparrow , $\overline{\text{CLK}}\downarrow$		ns
		Slow slew rate (see Notes 8 and 9)			

- NOTES: 5. V_{REF} must be held at a valid input level, and data inputs must be held low for a minimum time of t_{act} max, after $\overline{\text{RESET}}$ is taken high.
6. V_{REF} , data, and clock inputs must be held at valid voltage levels (not floating) for a minimum time of t_{inact} max, after $\overline{\text{RESET}}$ is taken low.
7. Data signal input slew rate $\geq 1\text{ V/ns}$
8. Data signal input slew rate $\geq 0.5\text{ V/ns}$ and $< 1\text{ V/ns}$
9. CLK, $\overline{\text{CLK}}$ input slew rates are $\geq 1\text{ V/ns}$.

switching characteristics over recommended operating free-air temperature range (unless otherwise noted) (see Figure 1)

PARAMETER	FROM (INPUT)	TO (OUTPUT)	$V_{CC} = 2.5\text{ V}$ $\pm 0.2\text{ V}$		UNIT
			MIN	MAX	
f_{max}			200		MHz
t_{pd}	CLK and $\overline{\text{CLK}}$	Q	1.1	3.1	ns
t_{PHL}	$\overline{\text{RESET}}$	Q		5	ns

SN74SSTV32852
24-BIT TO 48-BIT REGISTERED BUFFER
WITH SSTL_2 INPUTS AND OUTPUTS

SCES361C – AUGUST 2001 – REVISED FEBRUARY 2003

PARAMETER MEASUREMENT INFORMATION

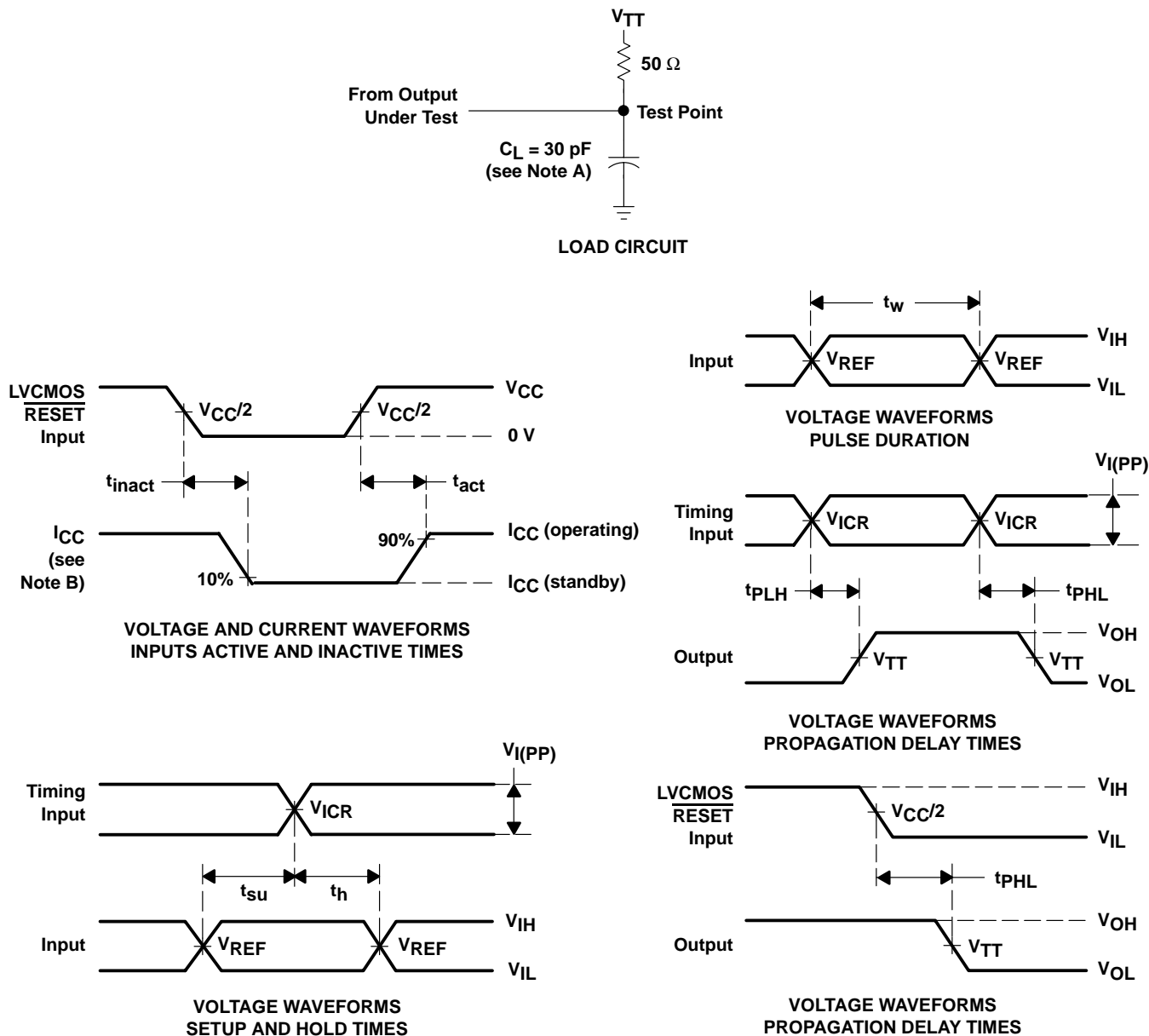

- NOTES:
- A. C_L includes probe and jig capacitance.
 - B. I_{CC} tested with clock and data inputs held at V_{CC} or GND, and $I_O = 0$ mA.
 - C. All input pulses are supplied by generators having the following characteristics: $PRR \leq 10$ MHz, $Z_O = 50 \Omega$, input slew rate = 1 V/ns $\pm 20\%$ (unless otherwise noted).
 - D. The outputs are measured one at a time with one transition per measurement.
 - E. $V_{TT} = V_{REF} = V_{DDQ}/2$
 - F. $V_{IH} = V_{REF} + 310$ mV (ac voltage levels) for differential inputs. $V_{IH} = V_{CC}$ for LVC MOS input.
 - G. $V_{IL} = V_{REF} - 310$ mV (ac voltage levels) for differential inputs. $V_{IL} = \text{GND}$ for LVC MOS input.
 - H. t_{PLH} and t_{PHL} are the same as t_{pd} .

Figure 1. Load Circuit and Voltage Waveforms

PACKAGING INFORMATION

Orderable Device	Status ⁽¹⁾	Package Type	Package Drawing	Pins	Package Qty	Eco Plan ⁽²⁾	Lead/Ball Finish	MSL Peak Temp ⁽³⁾
SN74SSTV32852GKFR	ACTIVE	LFBGA	GKF	114	1000	None	SNPB	Level-3-220C-168 HR
SN74SSTV32852ZKFR	ACTIVE	LFBGA	ZKF	114	1000	Green (RoHS & no Sb/Br)	SNAGCU	Level-3-250C-1WEEK

⁽¹⁾ The marketing status values are defined as follows:

ACTIVE: Product device recommended for new designs.

LIFEBUY: TI has announced that the device will be discontinued, and a lifetime-buy period is in effect.

NRND: Not recommended for new designs. Device is in production to support existing customers, but TI does not recommend using this part in a new design.

PREVIEW: Device has been announced but is not in production. Samples may or may not be available.

OBSELETE: TI has discontinued the production of the device.

⁽²⁾ Eco Plan - May not be currently available - please check <http://www.ti.com/productcontent> for the latest availability information and additional product content details.

None: Not yet available Lead (Pb-Free).

Pb-Free (RoHS): TI's terms "Lead-Free" or "Pb-Free" mean semiconductor products that are compatible with the current RoHS requirements for all 6 substances, including the requirement that lead not exceed 0.1% by weight in homogeneous materials. Where designed to be soldered at high temperatures, TI Pb-Free products are suitable for use in specified lead-free processes.

Green (RoHS & no Sb/Br): TI defines "Green" to mean "Pb-Free" and in addition, uses package materials that do not contain halogens, including bromine (Br) or antimony (Sb) above 0.1% of total product weight.

⁽³⁾ MSL, Peak Temp. -- The Moisture Sensitivity Level rating according to the JEDEC industry standard classifications, and peak solder temperature.

Important Information and Disclaimer:The information provided on this page represents TI's knowledge and belief as of the date that it is provided. TI bases its knowledge and belief on information provided by third parties, and makes no representation or warranty as to the accuracy of such information. Efforts are underway to better integrate information from third parties. TI has taken and continues to take reasonable steps to provide representative and accurate information but may not have conducted destructive testing or chemical analysis on incoming materials and chemicals. TI and TI suppliers consider certain information to be proprietary, and thus CAS numbers and other limited information may not be available for release.

In no event shall TI's liability arising out of such information exceed the total purchase price of the TI part(s) at issue in this document sold by TI to Customer on an annual basis.

GKF (R-PBGA-N114)

PLASTIC BALL GRID ARRAY

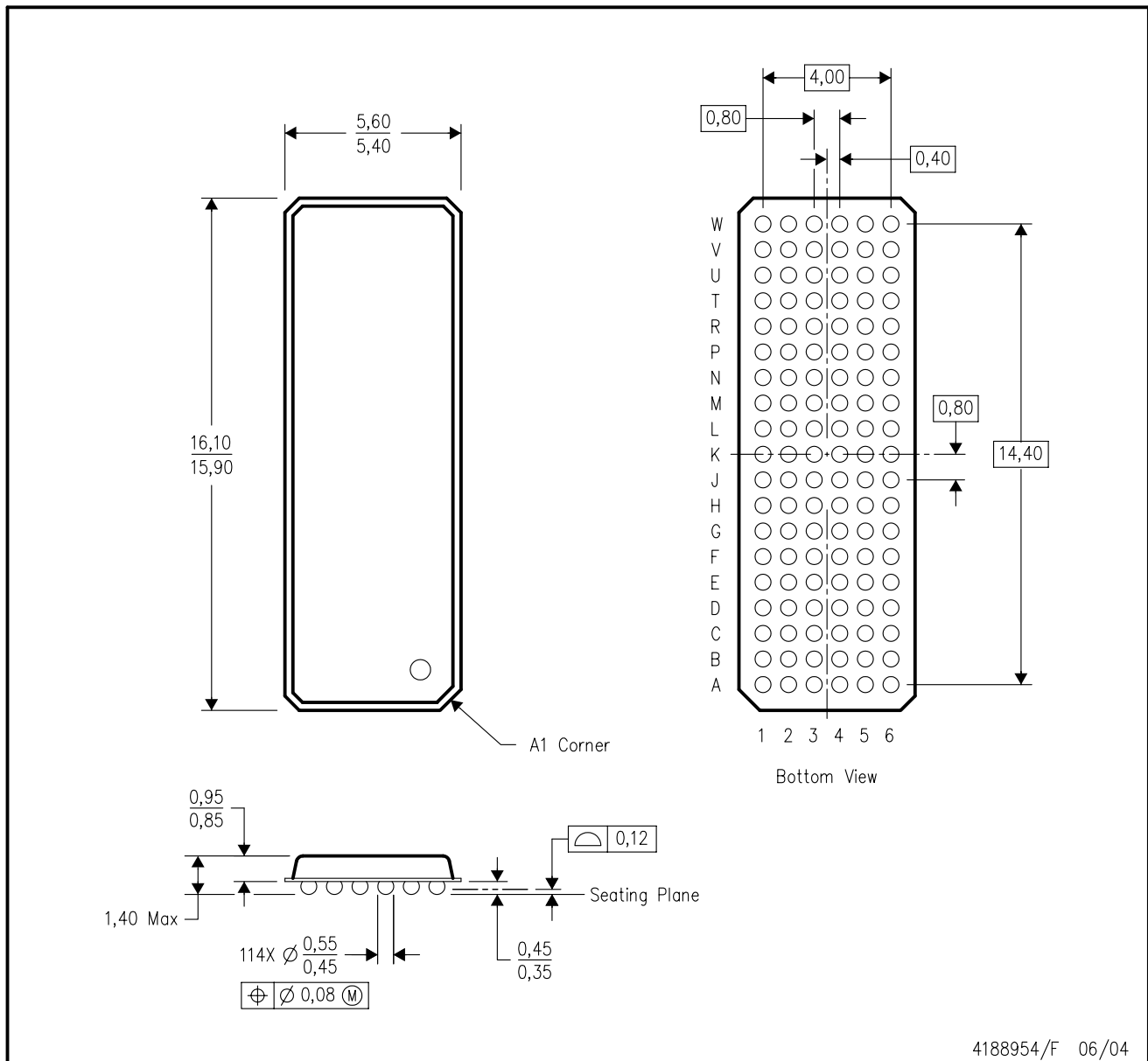

4188954/F 06/04

- NOTES:
- A. All linear dimensions are in millimeters.
 - B. This drawing is subject to change without notice.
 - C. Falls within JEDEC MO-205 variation DC.
 - D. This package is tin-lead (SnPb). Refer to the 114 ZKF package (drawing 4204494) for lead-free.

ZKF (R-PBGA-N114)

PLASTIC BALL GRID ARRAY

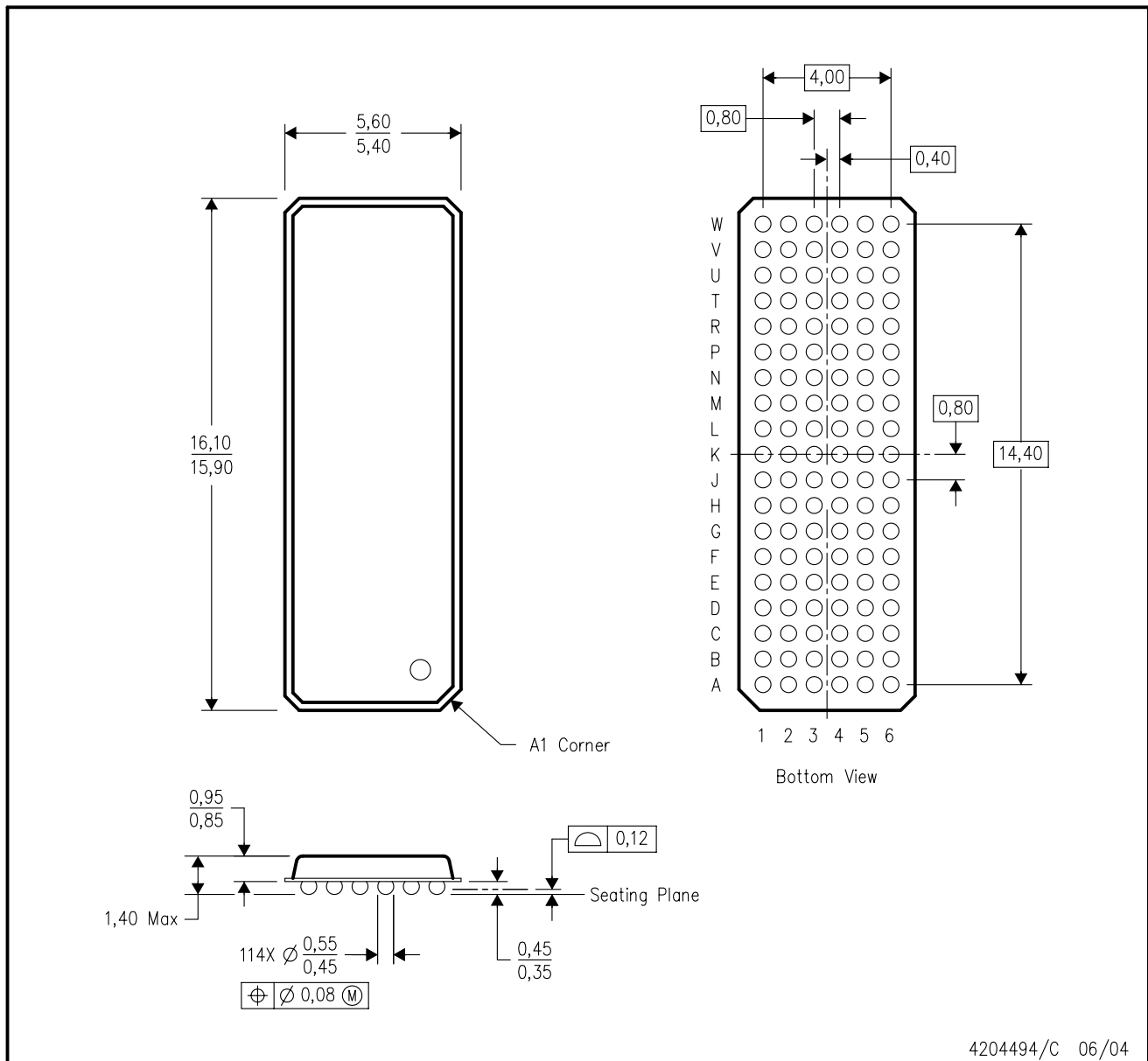

- NOTES:
- A. All linear dimensions are in millimeters.
 - B. This drawing is subject to change without notice.
 - C. Falls within JEDEC MO-205 variation DC.
 - D. This package is lead-free. Refer to the 114 GKF package (drawing 4188954) for tin-lead (SnPb).

IMPORTANT NOTICE

Texas Instruments Incorporated and its subsidiaries (TI) reserve the right to make corrections, modifications, enhancements, improvements, and other changes to its products and services at any time and to discontinue any product or service without notice. Customers should obtain the latest relevant information before placing orders and should verify that such information is current and complete. All products are sold subject to TI's terms and conditions of sale supplied at the time of order acknowledgment.

TI warrants performance of its hardware products to the specifications applicable at the time of sale in accordance with TI's standard warranty. Testing and other quality control techniques are used to the extent TI deems necessary to support this warranty. Except where mandated by government requirements, testing of all parameters of each product is not necessarily performed.

TI assumes no liability for applications assistance or customer product design. Customers are responsible for their products and applications using TI components. To minimize the risks associated with customer products and applications, customers should provide adequate design and operating safeguards.

TI does not warrant or represent that any license, either express or implied, is granted under any TI patent right, copyright, mask work right, or other TI intellectual property right relating to any combination, machine, or process in which TI products or services are used. Information published by TI regarding third-party products or services does not constitute a license from TI to use such products or services or a warranty or endorsement thereof. Use of such information may require a license from a third party under the patents or other intellectual property of the third party, or a license from TI under the patents or other intellectual property of TI.

Reproduction of information in TI data books or data sheets is permissible only if reproduction is without alteration and is accompanied by all associated warranties, conditions, limitations, and notices. Reproduction of this information with alteration is an unfair and deceptive business practice. TI is not responsible or liable for such altered documentation.

Resale of TI products or services with statements different from or beyond the parameters stated by TI for that product or service voids all express and any implied warranties for the associated TI product or service and is an unfair and deceptive business practice. TI is not responsible or liable for any such statements.

Following are URLs where you can obtain information on other Texas Instruments products and application solutions:

Products		Applications	
Amplifiers	amplifier.ti.com	Audio	www.ti.com/audio
Data Converters	dataconverter.ti.com	Automotive	www.ti.com/automotive
DSP	dsp.ti.com	Broadband	www.ti.com/broadband
Interface	interface.ti.com	Digital Control	www.ti.com/digitalcontrol
Logic	logic.ti.com	Military	www.ti.com/military
Power Mgmt	power.ti.com	Optical Networking	www.ti.com/opticalnetwork
Microcontrollers	microcontroller.ti.com	Security	www.ti.com/security
		Telephony	www.ti.com/telephony
		Video & Imaging	www.ti.com/video
		Wireless	www.ti.com/wireless

Mailing Address: Texas Instruments
Post Office Box 655303 Dallas, Texas 75265