

SN75185 MULTIPLE RS-232 DRIVERS AND RECEIVERS

SLLS181B – DECEMBER 1994 – REVISED MARCH 2001

- **Single Chip With Easy Interface Between UART and Serial-Port Connector of IBM™ PC/AT™ and Compatibles**
- **Meets or Exceeds the Requirements of TIA/EIA-232-F and ITU v.28 Standards**
- **Supports Data Rates up to 120 kbit/s**
- **ESD Protection Meets or Exceeds 10 kV on RS-232 Pins and 3.5 kV on All Other Pins (Human-Body Model)**
- **Pin-to-Pin Compatible With the SN75C185**

**DW OR N PACKAGE
(TOP VIEW)**

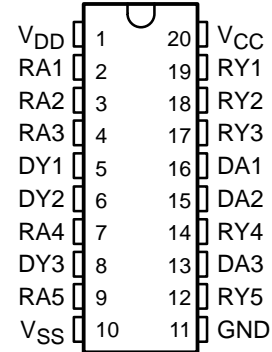

description

The SN75185 combines three drivers and five receivers from the TI SN75188 and SN75189 bipolar quadruple drivers and receivers, respectively. The pinout matches the flow-through design of the SN75C185 to decrease the part count, reduce the board space required, and allow easy interconnection of the UART and serial-port connector of IBM™ PC/AT™ and compatibles. The bipolar circuits and processing of the SN75185 provide a rugged low-cost solution for this function at the expense of quiescent power and external passive components relative to the SN75C185.

The SN75185 complies with the requirements of the TIA/EIA-232-F and ITU v.28 standards. These standards are for data interchange between a host computer and peripheral at signaling rates up to 20 kbit/s. The switching speeds of the SN75185 are fast enough to support rates up to 120 kbit/s with lower capacitive loads (shorter cables). Interoperability at the higher signaling rates cannot be assured unless the designer has design control of the cable and the interface circuits at both ends. For interoperability at signaling rates to 120 kbit/s, use of TIA/EIA-423-B (ITU v.10) and TIA/EIA-422-B (ITU v.11) standards is recommended.

The SN75185 is characterized for operation over the temperature range of 0°C to 70°C.

logic symbol†

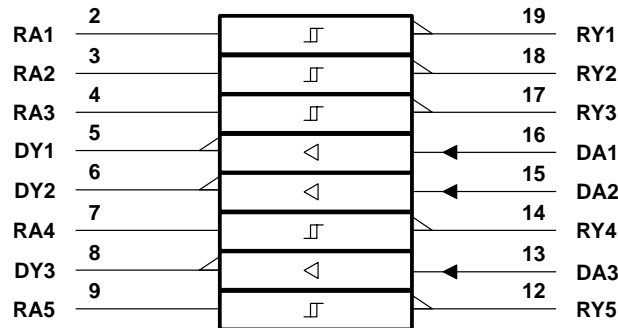

† This symbol is in accordance with ANSI/IEEE Std 91-1984 and IEC Publication 617-12.



Please be aware that an important notice concerning availability, standard warranty, and use in critical applications of Texas Instruments semiconductor products and disclaimers thereto appears at the end of this data sheet.

IBM and PC/AT are trademarks of IBM Corporation.

PRODUCTION DATA information is current as of publication date. Products conform to specifications per the terms of Texas Instruments standard warranty. Production processing does not necessarily include testing of all parameters.



POST OFFICE BOX 655303 • DALLAS, TEXAS 75265

Copyright © 2001, Texas Instruments Incorporated

SN75185 MULTIPLE RS-232 DRIVERS AND RECEIVERS

SLLS181B – DECEMBER 1994 – REVISED MARCH 2001

logic diagram (positive logic)

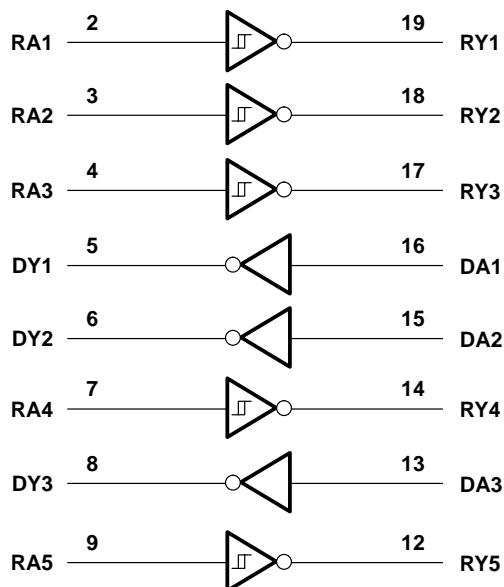

schematic of drivers

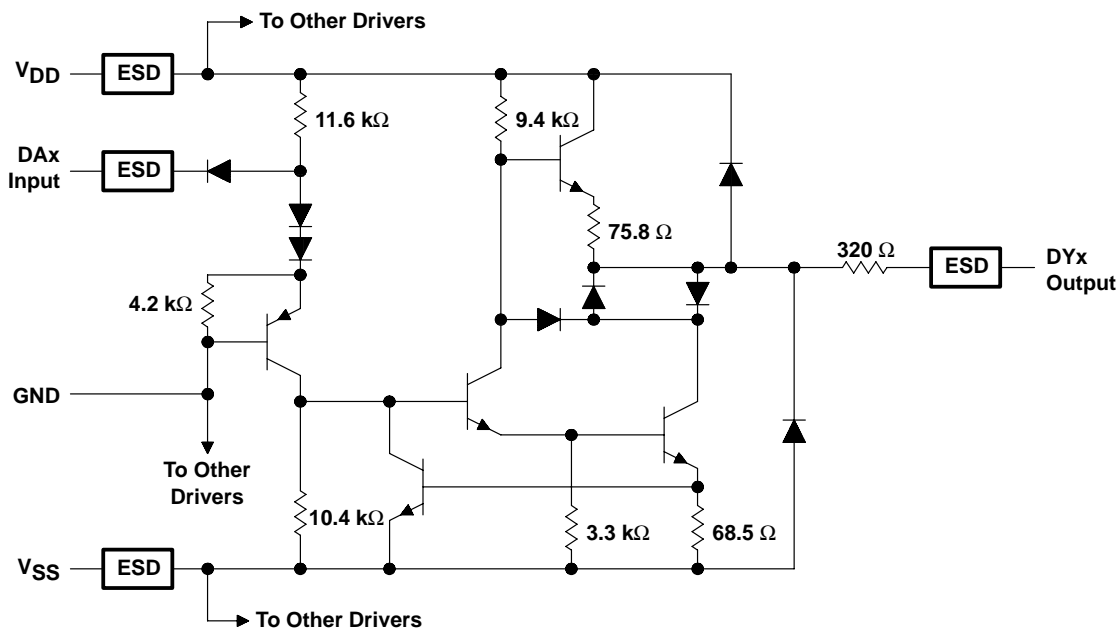

Resistor values shown are nominal.

schematic (each receiver)

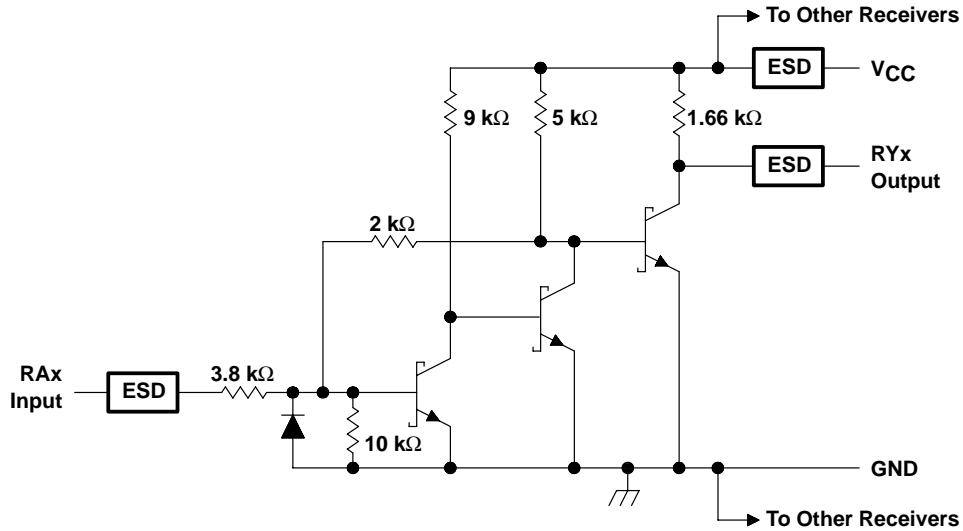

Resistor values shown are nominal.

absolute maximum ratings over operating free-air temperature range (unless otherwise noted)†

Supply voltage (see Note 1): V_{CC}	10 V
V_{DD}	15 V
V_{SS}	-15 V
Input voltage range: Driver	-15 V to 7 V
Receiver	-30 V to 30 V
Driver output voltage range	-15 V to 15 V
Receiver low-level output current	20 mA
Package thermal impedance, θ_{JA} (see Note 2): DW package	58°C/W
N package	69°C/W
Electrostatic discharge: Human-body model: RS-232 pins, class 3, A (see Note 3)	10 kV
All pins, class 3, A (see Note 4)	3.5 kV
Machine model: RS-232 pins, class 3, B (see Note 5)	600 V
All pins, class 3, B (see Note 4)	250 V
Lead temperature 1,6 mm (1/16 inch) from case for 10 seconds	260°C
Storage temperature range, T_{Stg}	-65°C to 150°C

† Stresses beyond those listed under “absolute maximum ratings” may cause permanent damage to the device. These are stress ratings only, and functional operation of the device at these or any other conditions beyond those indicated under “recommended operating conditions” is not implied. Exposure to absolute-maximum-rated conditions for extended periods may affect device reliability.

- NOTES: 1. All voltages are with respect to the network ground terminal.
 2. The package thermal impedance is calculated in accordance with JESD 51-7.
 3. RS-232 pins are tested with respect to ground and to each other.
 4. Per Mil-PRF-38535
 5. RS-232 pins are tested with respect to ground.

SN75185 MULTIPLE RS-232 DRIVERS AND RECEIVERS

SLLS181B – DECEMBER 1994 – REVISED MARCH 2001

recommended operating conditions

		MIN	NOM	MAX	UNIT
V _{CC}	Supply voltage	4.5	5	5.5	V
V _{DD}	Supply voltage	7.5	9	15	V
V _{SS}	Supply voltage	-7.5	-9	-15	V
V _{IH}	High-level input voltage (drivers only)	1.9			V
V _{IL}	Low-level input voltage (drivers only)			0.8	V
I _{OH}	High-level output current	Drivers		-6	mA
		Receivers		-0.5	
I _{OL}	Low-level output current	Drivers		6	mA
		Receivers		16	
T _A	Operating free-air temperature	0		70	°C

supply currents

PARAMETER	TEST CONDITIONS		MIN	MAX	UNIT
I _{CC}	Supply current from V _{CC}	All inputs at 5 V, No load, V _{CC} = 5 V		30	mA
I _{DD}	Supply current from V _{DD}	All inputs at 1.9 V, No load	V _{DD} = 9 V, V _{SS} = -9 V	15	mA
			V _{DD} = 12 V, V _{SS} = -12 V	19	
			V _{DD} = 15 V, V _{SS} = -15 V	25	
		All inputs at 0.8 V, No load	V _{DD} = 9 V, V _{SS} = -9 V	4.5	
			V _{DD} = 12 V, V _{SS} = -12 V	5.5	
			V _{DD} = 15 V, V _{SS} = -15 V	9	
I _{SS}	Supply current from V _{SS}	All inputs at 1.9 V, No load	V _{DD} = 9 V, V _{SS} = -9 V	-15	mA
			V _{DD} = 12 V, V _{SS} = -12 V	-19	
			V _{DD} = 15 V, V _{SS} = -15 V	-25	
		All inputs at 0.8 V, No load	V _{DD} = 9 V, V _{SS} = -9 V	-3.2	
			V _{DD} = 12 V, V _{SS} = -12 V	-3.2	
			V _{DD} = 15 V, V _{SS} = -15 V	-3.2	



DRIVER SECTION

electrical characteristics over recommended operating free-air temperature range, $V_{DD} = 9\text{ V}$, $V_{SS} = -9\text{ V}$, $V_{CC} = 5\text{ V}$ (unless otherwise noted)

PARAMETER		TEST CONDITIONS			MIN	TYP	MAX	UNIT
V_{OH}	High-level output voltage	$V_{IL} = 0.8\text{ V}$,	$R_L = 3\text{ k}\Omega$,	See Figure 1	6	7.5		V
V_{OL}	Low-level output voltage (see Note 6)	$V_{IH} = 1.9\text{ V}$,	$R_L = 3\text{ k}\Omega$,	See Figure 1		-7.5	-6	V
I_{IH}	High-level input current	$V_I = 5\text{ V}$,	See Figure 2				10	μA
I_{IL}	Low-level input current	$V_I = 0$,	See Figure 2				-1.6	mA
$I_{OS(H)}$	High-level short-circuit output current (see Note 7)	$V_{IL} = 0.8\text{ V}$,	$V_O = 0$,	See Figure 1	-4.5	-12	-19.5	mA
$I_{OS(L)}$	Low-level short-circuit output current	$V_{IH} = 2\text{ V}$,	$V_O = 0$,	See Figure 1	4.5	12	19.5	mA
r_o	Output resistance (see Note 8)	$V_{CC} = V_{DD} = V_{SS} = 0$,		$V_O = -2\text{ V to } 2\text{ V}$	300			Ω

- NOTES: 6. The algebraic convention, where the more positive (less negative) limit is designated as maximum, is used in this data sheet for logic levels only (e.g., if -10 V is maximum, the typical value is a more negative voltage).
7. Output short-circuit conditions must maintain the total power dissipation below absolute maximum ratings.
8. Test conditions are those specified by TIA/EIA-232-F and as listed above.

switching characteristics, $V_{CC} = 5\text{ V}$, $V_{DD} = 12\text{ V}$, $V_{SS} = -12\text{ V}$, $T_A = 25^\circ\text{C}$ (see Figure 3)

PARAMETER		TEST CONDITIONS		MIN	TYP	MAX	UNIT
t_{PLH}	Propagation delay time, low-to-high-level output	$R_L = 3\text{ k}\Omega$ to $7\text{ k}\Omega$,	$C_L = 15\text{ pF}$		315	500	ns
t_{PHL}	Propagation delay time, high-to-low-level output	$R_L = 3\text{ k}\Omega$ to $7\text{ k}\Omega$,	$C_L = 15\text{ pF}$		75	175	ns
t_{TLH}	Transition time, low-to-high-level output	$R_L = 3\text{ k}\Omega$ to $7\text{ k}\Omega$	$C_L = 15\text{ pF}$		60	100	ns
			$C_L = 2500\text{ pF}$, See Note 9		1.7	2.5	μs
t_{THL}	Transition time, high-to-low-level output	$R_L = 3\text{ k}\Omega$ to $7\text{ k}\Omega$	$C_L = 15\text{ pF}$		40	75	ns
			$C_L = 2500\text{ pF}$, See Note 10		1.5	2.5	μs

- NOTES: 9. Measured between -3-V and 3-V points of the output waveform (TIA/EIA-232-F conditions); all unused inputs are tied either high or low.
10. Measured between 3-V and -3-V points of the output waveform (TIA/EIA-232-F conditions); all unused inputs are tied either high or low.

SN75185 MULTIPLE RS-232 DRIVERS AND RECEIVERS

SLLS181B – DECEMBER 1994 – REVISED MARCH 2001

RECEIVER SECTION

electrical characteristics over recommended operating conditions (unless otherwise noted)

PARAMETER	TEST CONDITIONS		MIN	TYP†	MAX	UNIT
V_{T+} Positive-going threshold voltage	See Figure 5	$T_A = 25^\circ\text{C}$	1.75	1.9	2.3	V
		$T_A = 0^\circ\text{C to } 70^\circ\text{C}$	1.55		2.3	
V_{T-} Negative-going threshold voltage			0.75	0.97	1.25	
V_{hys} Input hysteresis ($V_{T+} - V_{T-}$)			0.5			
V_{OH} High-level output voltage	$I_{OH} = -0.5\text{ mA}$	$V_{IH} = 0.75\text{ V}$	2.6	4	5	V
		Inputs open	2.6			
V_{OL} Low-level output voltage	$I_{OL} = 10\text{ mA},$	$V_I = 3\text{ V}$		0.2	0.45	V
I_{IH} High-level input current	$V_I = 25\text{ V},$	See Figure 5	3.6		8.3	mA
	$V_I = 3\text{ V},$	See Figure 5	0.43			
I_{IL} Low-level output current	$V_I = -25\text{ V},$	See Figure 5	-3.6		-8.3	mA
	$V_I = -3\text{ V},$	See Figure 5	-0.43			
I_{OS} Short-circuit output current	See Figure 4			-3.4	-12	mA

† All typical values are at $T_A = 25^\circ\text{C}$, $V_{CC} = 5\text{ V}$, $V_{DD} = 9\text{ V}$, and $V_{SS} = -9\text{ V}$.

switching characteristics, $V_{CC} = 5\text{ V}$, $V_{DD} = 12\text{ V}$, $V_{SS} = -12\text{ V}$, $T_A = 25^\circ\text{C}$ (see Figure 6)

PARAMETER	TEST CONDITIONS		MIN	TYP	MAX	UNIT
t_{PLH} Propagation delay time, low-to-high-level output	$C_L = 50\text{ pF},$	$R_L = 5\text{ k}\Omega$		107	500	ns
t_{PHL} Propagation delay time, high-to-low-level output	$C_L = 50\text{ pF},$	$R_L = 5\text{ k}\Omega$		42	150	ns
t_{TLH} Transition time, low-to-high-level output	$C_L = 50\text{ pF},$	$R_L = 5\text{ k}\Omega$		175	525	ns
t_{THL} Transition time, high-to-low-level output	$C_L = 50\text{ pF},$	$R_L = 5\text{ k}\Omega$		16	60	ns

PARAMETER MEASUREMENT INFORMATION

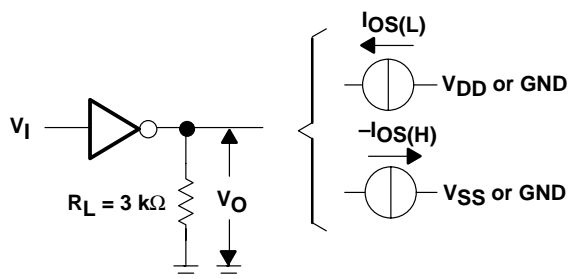

Figure 1. Driver Test Circuit for V_{OH} , V_{OL} , $I_{OS(H)}$, and $I_{OS(L)}$

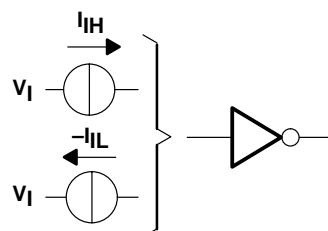
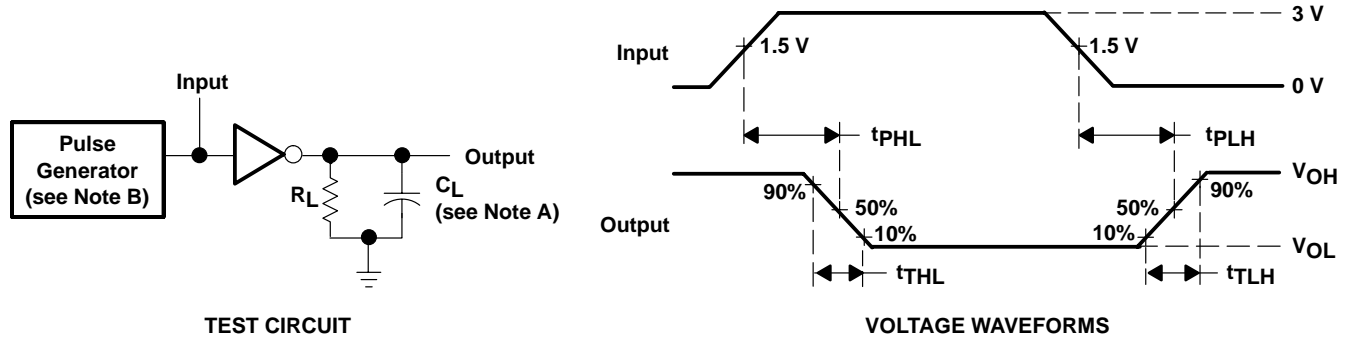

Figure 2. Driver Test Circuit for I_{IH} and I_{IL}

PARAMETER MEASUREMENT INFORMATION



NOTES: A. C_L includes probe and jig capacitance.
 B. The pulse generator has the following characteristics: $t_w = 25 \mu s$, $PRR = 20 \text{ kHz}$, $Z_O = 50 \Omega$, $t_r = t_f < 50 \text{ ns}$.

Figure 3. Driver Test Circuit and Voltage Waveforms

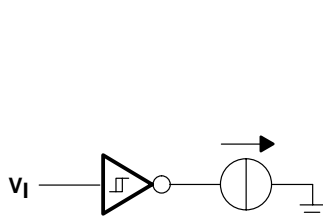

Figure 4. Receiver Test Circuit for I_{OS}

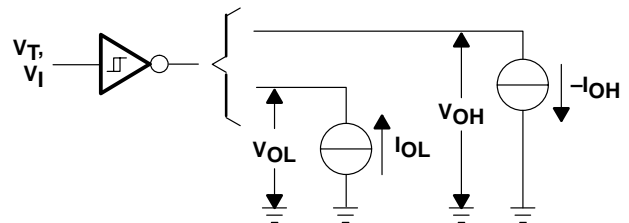
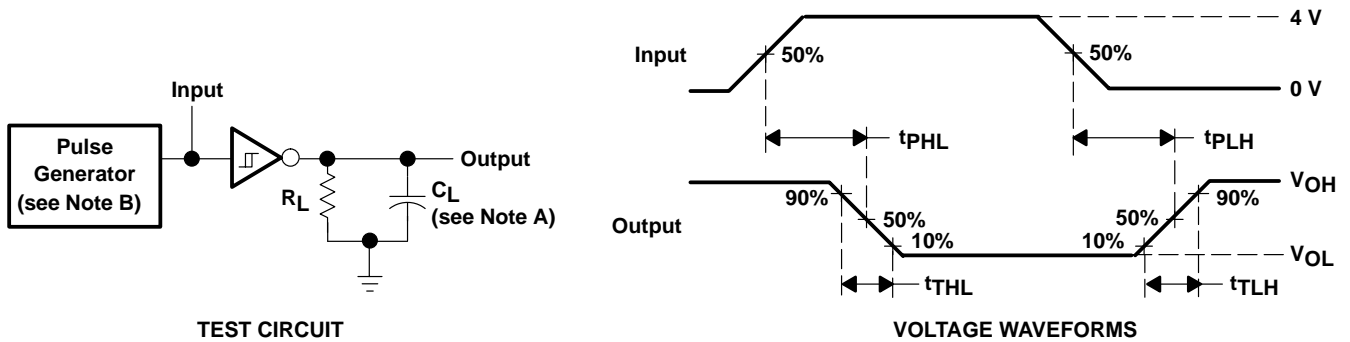

Figure 5. Receiver Test Circuit for V_T , V_{OH} , and V_{OL}



NOTES: A. C_L includes probe and jig capacitance.
 B. The pulse generator has the following characteristics: $t_w = 25 \mu s$, $PRR = 20 \text{ kHz}$, $Z_O = 50 \Omega$, $t_r = t_f < 50 \text{ ns}$.

Figure 6. Receiver Propagation and Transition Times

SN75185 MULTIPLE RS-232 DRIVERS AND RECEIVERS

SLLS181B – DECEMBER 1994 – REVISED MARCH 2001

TYPICAL CHARACTERISTICS

DRIVER SECTION

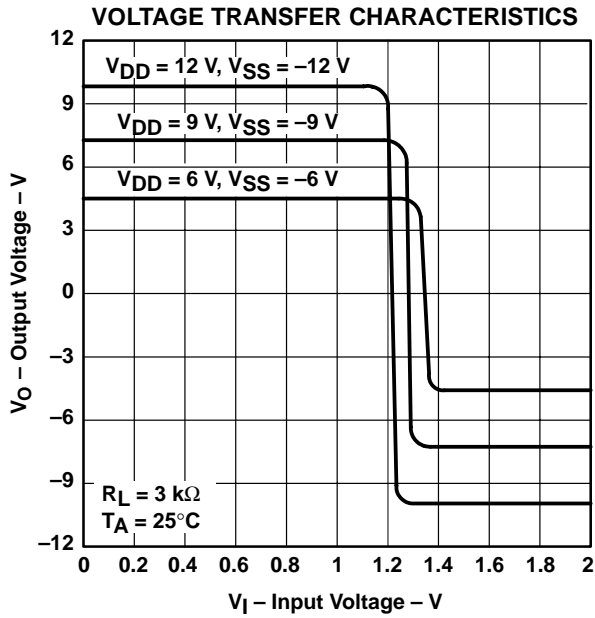

Figure 7

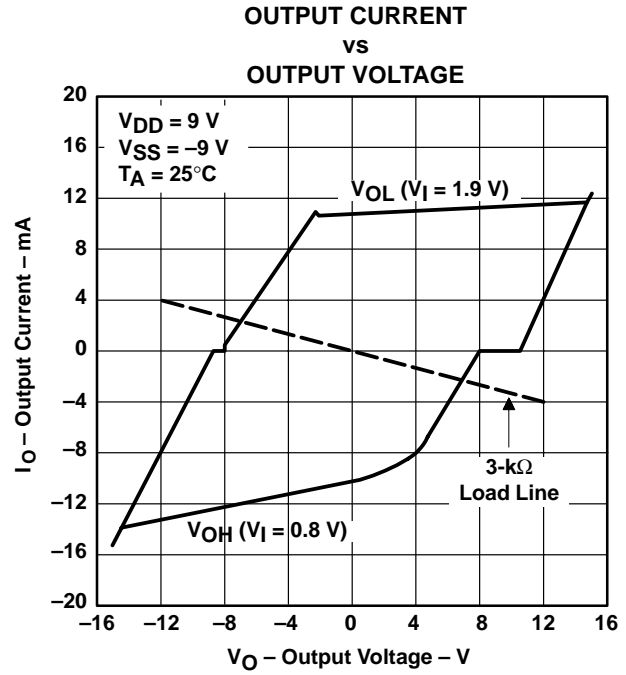

Figure 8

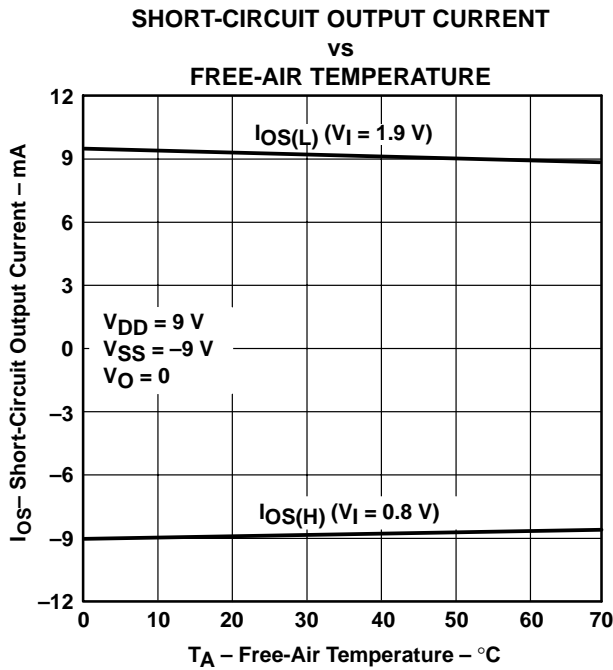

Figure 9

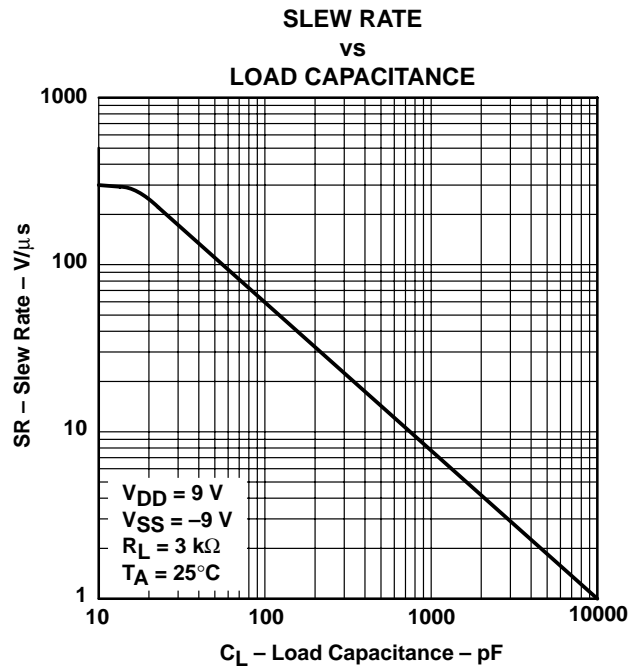

Figure 10



TYPICAL CHARACTERISTICS

RECEIVER SECTION

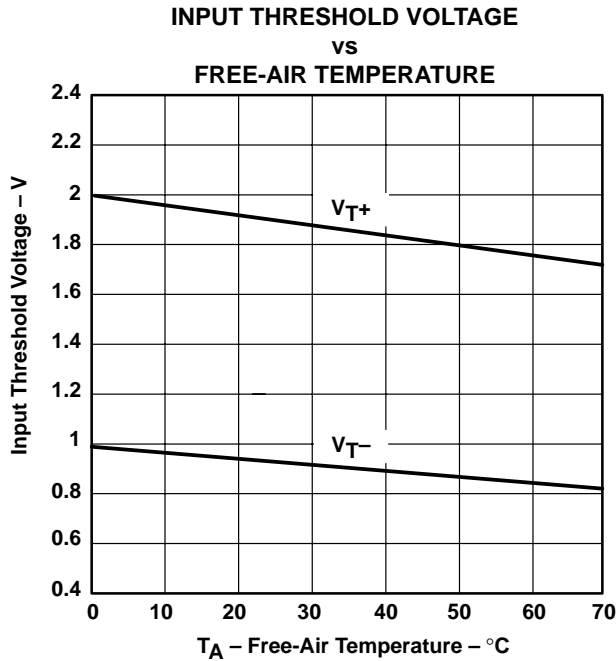

Figure 11

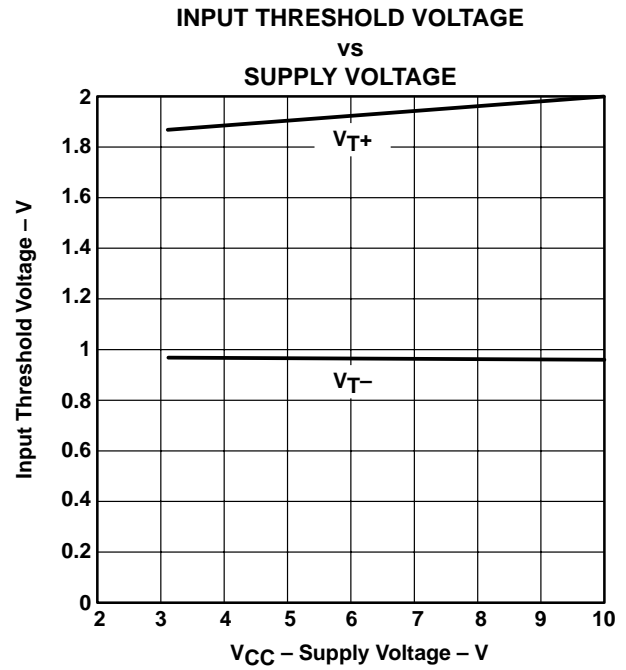
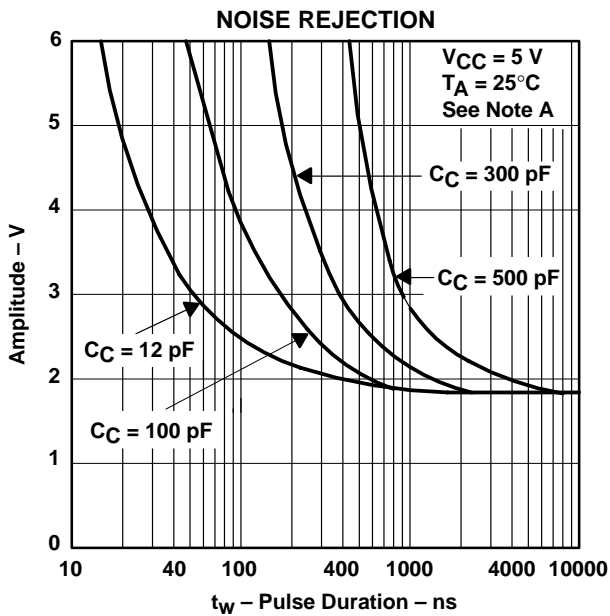

Figure 12



NOTE A: This figure shows the maximum amplitude of a positive-going pulse that, starting from 0 V, will not cause a change in the output level.

Figure 13

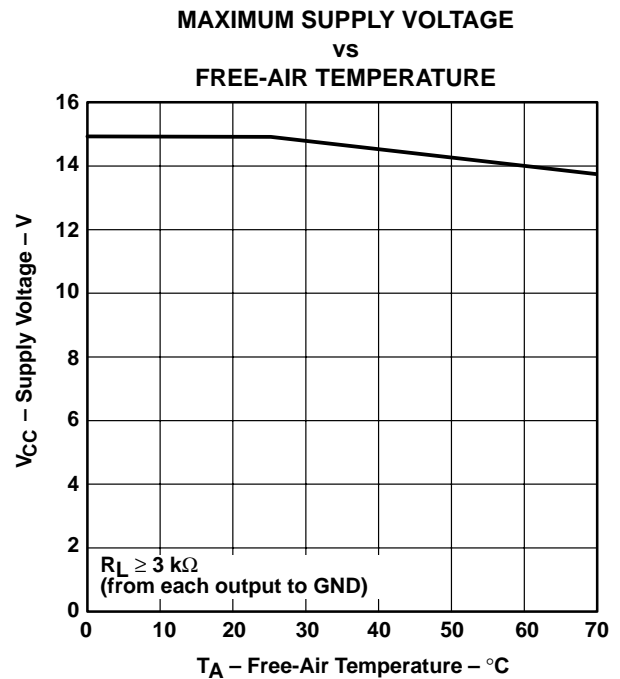

Figure 14

SN75185 MULTIPLE RS-232 DRIVERS AND RECEIVERS

SLLS181B – DECEMBER 1994 – REVISED MARCH 2001

APPLICATION INFORMATION

Diodes placed in series with the V_{DD} and V_{SS} leads protect the SN75185 in the fault condition. In the fault condition, the device outputs are shorted to ± 15 V, and the power supplies are at low and provide low-impedance paths to ground (see Figure 15).

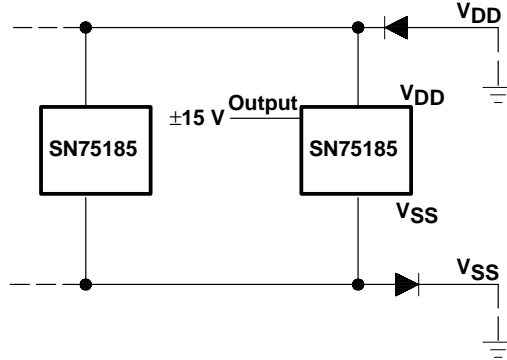
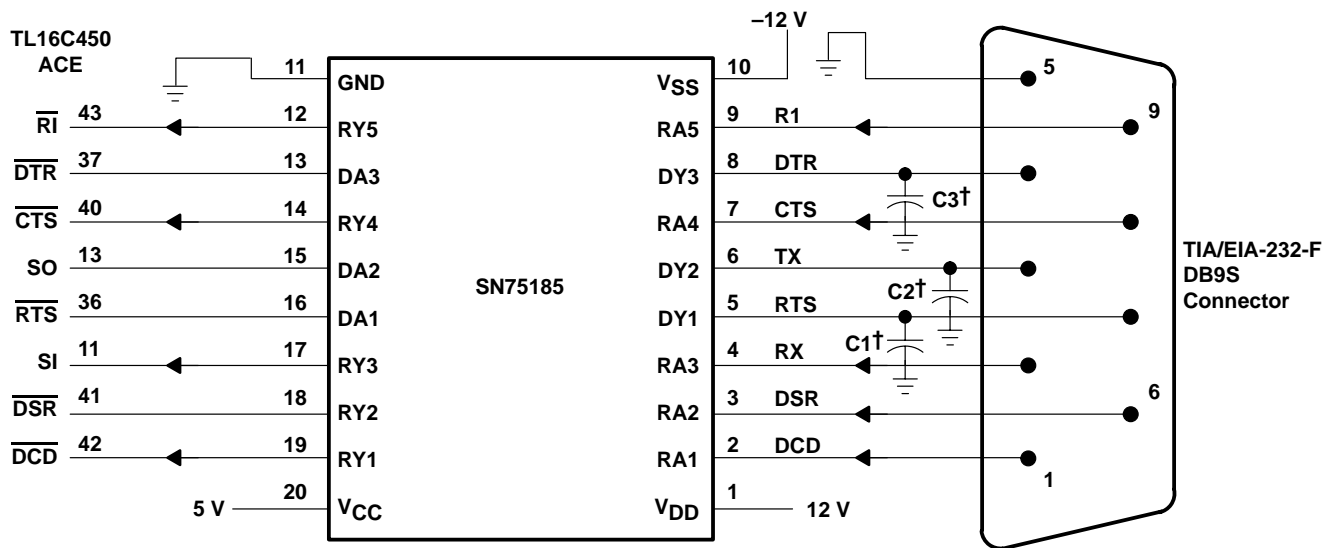

Figure 15. Power-Supply Protection to Meet Power-Off Fault Conditions of TIA/EIA-232-F



† See Figure 10 to select the correct values for the loading capacitors (C_1 , C_2 , and C_3), which are required to meet the RS-232 maximum slew-rate requirement of $30 \text{ V}/\mu\text{s}$. The value of the loading capacitors required depends on the line length and desired slew rate, but typically is 330 pF .

Figure 16. Typical Connection

IMPORTANT NOTICE

Texas Instruments and its subsidiaries (TI) reserve the right to make changes to their products or to discontinue any product or service without notice, and advise customers to obtain the latest version of relevant information to verify, before placing orders, that information being relied on is current and complete. All products are sold subject to the terms and conditions of sale supplied at the time of order acknowledgment, including those pertaining to warranty, patent infringement, and limitation of liability.

TI warrants performance of its products to the specifications applicable at the time of sale in accordance with TI's standard warranty. Testing and other quality control techniques are utilized to the extent TI deems necessary to support this warranty. Specific testing of all parameters of each device is not necessarily performed, except those mandated by government requirements.

Customers are responsible for their applications using TI components.

In order to minimize risks associated with the customer's applications, adequate design and operating safeguards must be provided by the customer to minimize inherent or procedural hazards.

TI assumes no liability for applications assistance or customer product design. TI does not warrant or represent that any license, either express or implied, is granted under any patent right, copyright, mask work right, or other intellectual property right of TI covering or relating to any combination, machine, or process in which such products or services might be or are used. TI's publication of information regarding any third party's products or services does not constitute TI's approval, license, warranty or endorsement thereof.

Reproduction of information in TI data books or data sheets is permissible only if reproduction is without alteration and is accompanied by all associated warranties, conditions, limitations and notices. Representation or reproduction of this information with alteration voids all warranties provided for an associated TI product or service, is an unfair and deceptive business practice, and TI is not responsible nor liable for any such use.

Resale of TI's products or services with statements different from or beyond the parameters stated by TI for that product or service voids all express and any implied warranties for the associated TI product or service, is an unfair and deceptive business practice, and TI is not responsible nor liable for any such use.

Also see: [Standard Terms and Conditions of Sale for Semiconductor Products](http://www.ti.com/sc/docs/stdterms.htm). www.ti.com/sc/docs/stdterms.htm

Mailing Address:

Texas Instruments
Post Office Box 655303
Dallas, Texas 75265