

SN754410 QUADRUPLE HALF-H DRIVER

SLRS007B – NOVEMBER 1986 – REVISED NOVEMBER 1995

- 1-A Output-Current Capability Per Driver
- Applications Include Half-H and Full-H Solenoid Drivers and Motor Drivers
- Designed for Positive-Supply Applications
- Wide Supply-Voltage Range of 4.5 V to 36 V
- TTL- and CMOS-Compatible High-Impedance Diode-Clamped Inputs
- Separate Input-Logic Supply
- Thermal Shutdown
- Internal ESD Protection
- Input Hysteresis Improves Noise Immunity
- 3-State Outputs
- Minimized Power Dissipation
- Sink/Source Interlock Circuitry Prevents Simultaneous Conduction
- No Output Glitch During Power Up or Power Down
- Improved Functional Replacement for the SGS L293

description

The SN754410 is a quadruple high-current half-H driver designed to provide bidirectional drive currents up to 1 A at voltages from 4.5 V to 36 V. The device is designed to drive inductive loads such as relays, solenoids, dc and bipolar stepping motors, as well as other high-current/high-voltage loads in positive-supply applications.

All inputs are compatible with TTL-and low-level CMOS logic. Each output (Y) is a complete totem-pole driver with a Darlington transistor sink and a pseudo-Darlington source. Drivers are enabled in pairs with drivers 1 and 2 enabled by 1,2EN and drivers 3 and 4 enabled by 3,4EN. When an enable input is high, the associated drivers are enabled and their outputs become active and in phase with their inputs. When the enable input is low, those drivers are disabled and their outputs are off and in a high-impedance state. With the proper data inputs, each pair of drivers form a full-H (or bridge) reversible drive suitable for solenoid or motor applications.

A separate supply voltage (V_{CC1}) is provided for the logic input circuits to minimize device power dissipation. Supply voltage V_{CC2} is used for the output circuits.

The SN754410 is designed for operation from -40°C to 85°C .

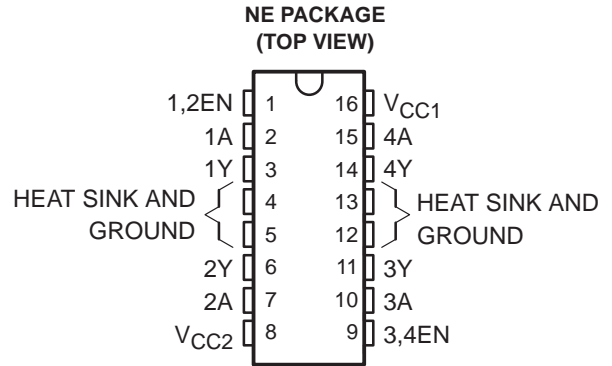

FUNCTION TABLE
(each driver)

INPUTS [†]		OUTPUT
A	EN	Y
H	H	H
L	H	L
X	L	Z

H = high-level, L = low-level

X = irrelevant

Z = high-impedance (off)

[†] In the thermal shutdown mode, the output is in a high-impedance state regardless of the input levels.

SN754410 QUADRUPLE HALF-H DRIVER

SLRS007B – NOVEMBER 1986 – REVISED NOVEMBER 1995

logic symbol†

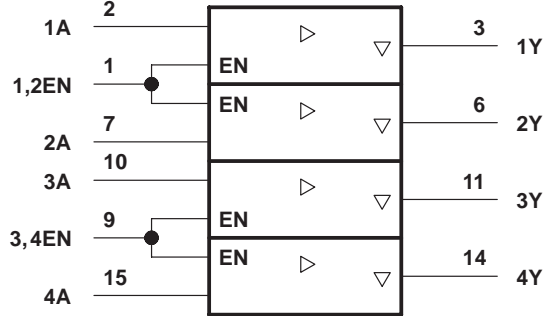

logic diagram

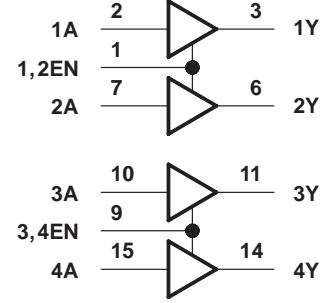

† This symbol is in accordance with ANSI/IEEE Std 91-1984 and IEC Publication 617-12.

schematics of inputs and outputs

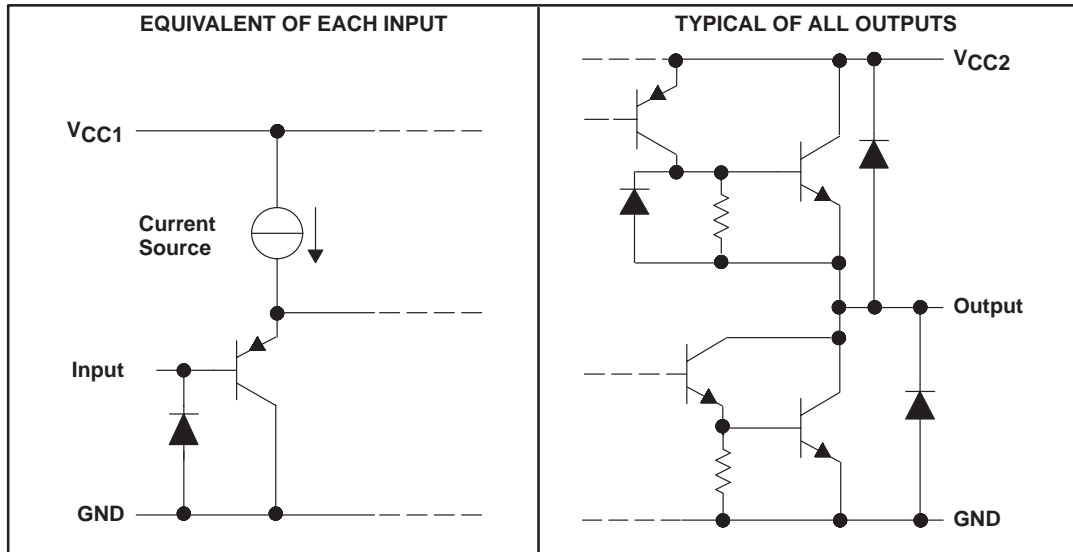

absolute maximum ratings over operating free-air temperature range (unless otherwise noted)†

Output supply voltage range, V_{CC1} (see Note 1)	–0.5 V to 36 V
Output supply voltage range, V_{CC2}	–0.5 V to 36 V
Input voltage, V_I	36 V
Output voltage range, V_O	–3 V to $V_{CC2} + 3$ V
Peak output current (nonrepetitive, $t_w \leq 5$ ms)	± 2 A
Continuous output current, I_O	± 1.1 A
Continuous total power dissipation at (or below) 25°C free-air temperature (see Note 2)	2075 mW
Operating free-air temperature range, T_A	–40°C to 85°C
Operating virtual junction temperature range, T_J	–40°C to 150°C
Storage temperature range, T_{stg}	–65°C to 150°C
Lead temperature 1,6 mm (1/16 inch) from case for 10 seconds	260°C

† Stresses beyond those listed under “absolute maximum ratings” may cause permanent damage to the device. These are stress ratings only, and functional operation of the device at these or any other conditions beyond those indicated under “recommended operating conditions” is not implied. Exposure to absolute-maximum-rated conditions for extended periods may affect device reliability.

- NOTES: 1. All voltage values are with respect to network GND.
 2. For operation above 25°C free-air temperature, derate linearly at the rate of 16.6 mW/°C. To avoid exceeding the design maximum virtual junction temperature, these ratings should not be exceeded. Due to variations in individual device electrical characteristics and thermal resistance, the built-in thermal overload protection can be activated at power levels slightly above or below the rated dissipation.

recommended operating conditions

	MIN	MAX	UNIT
Output supply voltage, V_{CC1}	4.5	5.5	V
Output supply voltage, V_{CC2}	4.5	36	V
High-level input voltage, V_{IH}	2	5.5	V
Low-level input voltage, V_{IL}	–0.3‡	0.8	V
Operating virtual junction temperature, T_J	–40	125	°C
Operating free-air temperature, T_A	–40	85	°C

‡ The algebraic convention, in which the least positive (most negative) limit is designated as minimum, is used in this data sheet for logic voltage levels.



SN754410 QUADRUPLE HALF-H DRIVER

SLRS007B – NOVEMBER 1986 – REVISED NOVEMBER 1995

electrical characteristics over recommended ranges of supply voltage and free-air temperature (unless otherwise noted)

PARAMETER		TEST CONDITIONS	MIN	TYP†	MAX	UNIT
V_{IK}	Input clamp voltage	$I_I = -12 \text{ mA}$		-0.9	-1.5	V
V_{OH}	High-level output voltage	$I_{OH} = -0.5 \text{ A}$	$V_{CC2} - 1.5$	$V_{CC2} - 1.1$		V
		$I_{OH} = -1 \text{ A}$	$V_{CC2} - 2$			
		$I_{OH} = -1 \text{ A}, T_J = 25^\circ\text{C}$	$V_{CC2} - 1.8$	$V_{CC2} - 1.4$		
V_{OL}	Low-level output voltage	$I_{OL} = 0.5 \text{ A}$		1	1.4	V
		$I_{OL} = 1 \text{ A}$			2	
		$I_{OL} = 1 \text{ A}, T_J = 25^\circ\text{C}$		1.2	1.8	
V_{OKH}	High-level output clamp voltage	$I_{OK} = -0.5 \text{ A}$		$V_{CC2} + 1.4$	$V_{CC2} + 2$	V
		$I_{OK} = 1 \text{ A}$		$V_{CC2} + 1.9$	$V_{CC2} + 2.5$	
V_{OKL}	Low-level output clamp voltage	$I_{OK} = 0.5 \text{ A}$		-1.1	-2	V
		$I_{OK} = -1 \text{ A}$		-1.3	-2.5	
$I_{OZ(off)}$	Off-state high-impedance-state output current	$V_O = V_{CC2}$			500	μA
		$V_O = 0$			-500	
I_{IH}	High-level input current	$V_I = 5.5 \text{ V}$			10	μA
I_{IL}	Low-level input current	$V_I = 0$			-10	μA
I_{CC1}	Output supply current	$I_O = 0$	All outputs at high level		38	mA
			All outputs at low level		70	
			All outputs at high impedance		25	
I_{CC2}	Output supply current	$I_O = 0$	All outputs at high level		33	mA
			All outputs at low level		20	
			All outputs at high impedance		5	

† All typical values are at $V_{CC1} = 5 \text{ V}$, $V_{CC2} = 24 \text{ V}$, $T_A = 25^\circ\text{C}$.

switching characteristics, $V_{CC1} = 5 \text{ V}$, $V_{CC2} = 24 \text{ V}$, $C_L = 30 \text{ pF}$, $T_A = 25^\circ\text{C}$

PARAMETER		TEST CONDITIONS	MIN	TYP	MAX	UNIT
t_{d1}	Delay time, high-to-low-level output from A input	See Figure 1		400		ns
t_{d2}	Delay time, low-to-high-level output from A input			800		ns
t_{TLH}	Transition time, low-to-high-level output			300		ns
t_{THL}	Transition time, high-to-low-level output			300		ns
t_r	Rise time, pulse input					
t_f	Fall time, pulse input					
t_w	Pulse duration					
t_{en1}	Enable time to the high level	See Figure 2		700		ns
t_{en2}	Enable time to the low level			400		ns
t_{dis1}	Disable time from the high level			900		ns
t_{dis2}	Disable time from the low level			600		ns



PARAMETER MEASUREMENT INFORMATION

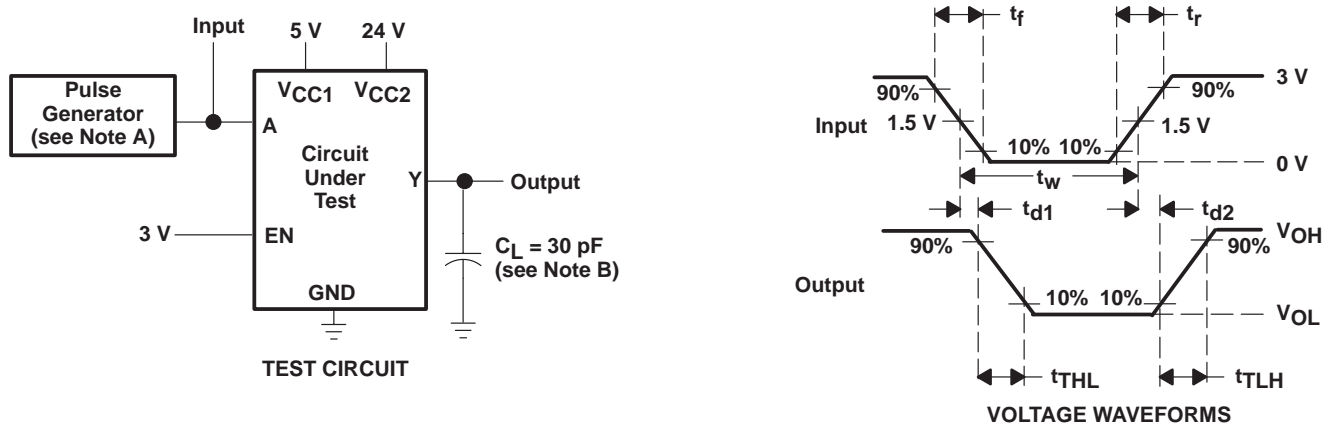

Figure 1. Test Circuit and Switching Times From Data Inputs

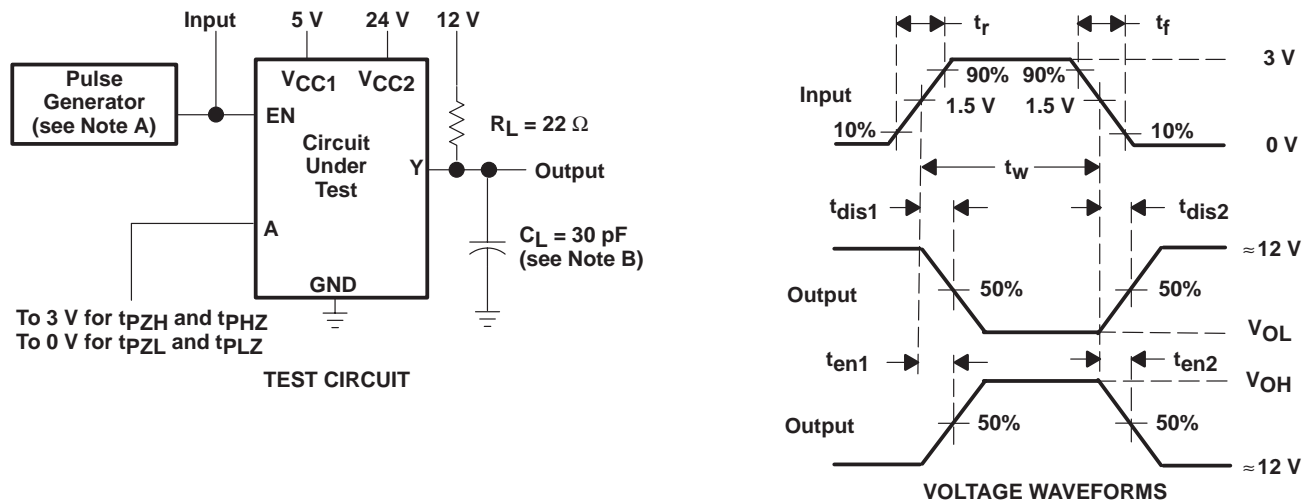

Figure 2. Test Circuit and Switching Times From Enable Inputs

NOTES: A. The pulse generator has the following characteristics: $t_r \leq 10$ ns, $t_f \leq 10$ ns, $t_w = 10$ μ s, PRR = 5 kHz, $Z_O = 50$ Ω .
 B. C_L includes probe and jig capacitance.

SN754410 QUADRUPLE HALF-H DRIVER

SLRS007B – NOVEMBER 1986 – REVISED NOVEMBER 1995

APPLICATION INFORMATION

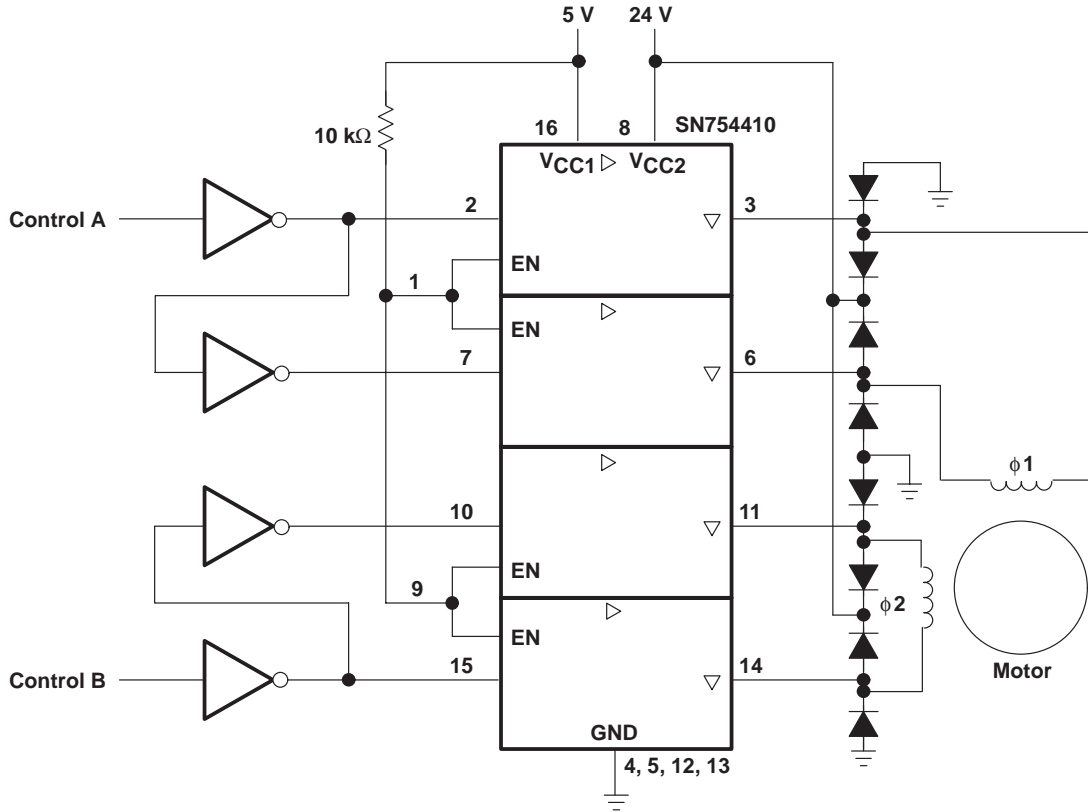

Figure 3. Two-Phase Motor Driver

PACKAGING INFORMATION

Orderable Device	Status ⁽¹⁾	Package Type	Package Drawing	Pins	Package Qty	Eco Plan ⁽²⁾	Lead/Ball Finish	MSL Peak Temp ⁽³⁾
SN754410NE	ACTIVE	PDIP	NE	16	25	Pb-Free (RoHS)	Call TI	Level-NC-NC-NC

⁽¹⁾ The marketing status values are defined as follows:

ACTIVE: Product device recommended for new designs.

LIFEBUY: TI has announced that the device will be discontinued, and a lifetime-buy period is in effect.

NRND: Not recommended for new designs. Device is in production to support existing customers, but TI does not recommend using this part in a new design.

PREVIEW: Device has been announced but is not in production. Samples may or may not be available.

OBSOLETE: TI has discontinued the production of the device.

⁽²⁾ Eco Plan - May not be currently available - please check <http://www.ti.com/productcontent> for the latest availability information and additional product content details.

None: Not yet available Lead (Pb-Free).

Pb-Free (RoHS): TI's terms "Lead-Free" or "Pb-Free" mean semiconductor products that are compatible with the current RoHS requirements for all 6 substances, including the requirement that lead not exceed 0.1% by weight in homogeneous materials. Where designed to be soldered at high temperatures, TI Pb-Free products are suitable for use in specified lead-free processes.

Green (RoHS & no Sb/Br): TI defines "Green" to mean "Pb-Free" and in addition, uses package materials that do not contain halogens, including bromine (Br) or antimony (Sb) above 0.1% of total product weight.

⁽³⁾ MSL, Peak Temp. -- The Moisture Sensitivity Level rating according to the JEDEC industry standard classifications, and peak solder temperature.

Important Information and Disclaimer: The information provided on this page represents TI's knowledge and belief as of the date that it is provided. TI bases its knowledge and belief on information provided by third parties, and makes no representation or warranty as to the accuracy of such information. Efforts are underway to better integrate information from third parties. TI has taken and continues to take reasonable steps to provide representative and accurate information but may not have conducted destructive testing or chemical analysis on incoming materials and chemicals. TI and TI suppliers consider certain information to be proprietary, and thus CAS numbers and other limited information may not be available for release.

In no event shall TI's liability arising out of such information exceed the total purchase price of the TI part(s) at issue in this document sold by TI to Customer on an annual basis.

NE (R-PDIP-T**)

PLASTIC DUAL-IN-LINE PACKAGE

20 PIN SHOWN

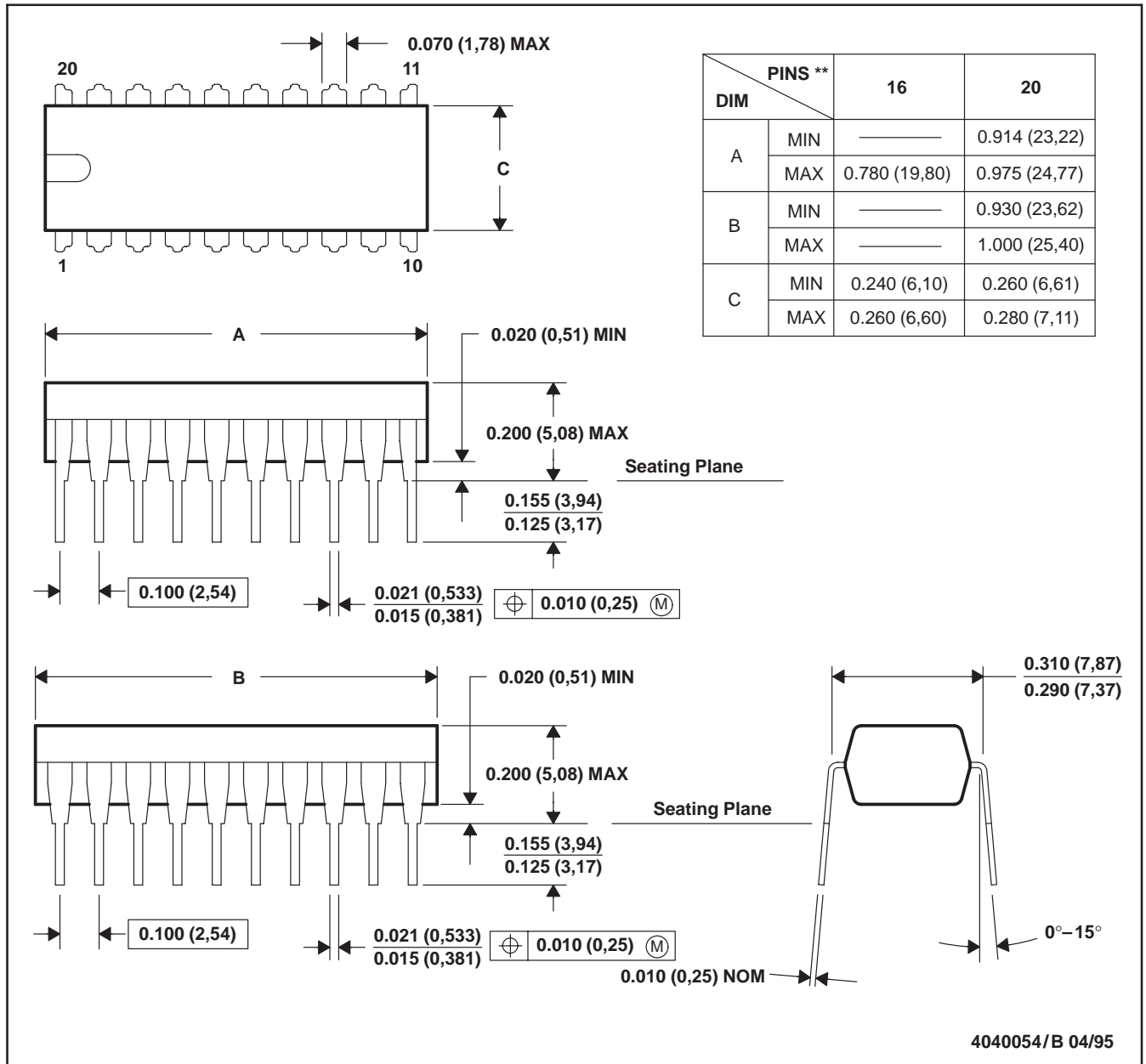

- NOTES: A. All linear dimensions are in inches (millimeters).
 B. This drawing is subject to change without notice.
 C. Falls within JEDEC MS-001 (16 pin only)

IMPORTANT NOTICE

Texas Instruments Incorporated and its subsidiaries (TI) reserve the right to make corrections, modifications, enhancements, improvements, and other changes to its products and services at any time and to discontinue any product or service without notice. Customers should obtain the latest relevant information before placing orders and should verify that such information is current and complete. All products are sold subject to TI's terms and conditions of sale supplied at the time of order acknowledgment.

TI warrants performance of its hardware products to the specifications applicable at the time of sale in accordance with TI's standard warranty. Testing and other quality control techniques are used to the extent TI deems necessary to support this warranty. Except where mandated by government requirements, testing of all parameters of each product is not necessarily performed.

TI assumes no liability for applications assistance or customer product design. Customers are responsible for their products and applications using TI components. To minimize the risks associated with customer products and applications, customers should provide adequate design and operating safeguards.

TI does not warrant or represent that any license, either express or implied, is granted under any TI patent right, copyright, mask work right, or other TI intellectual property right relating to any combination, machine, or process in which TI products or services are used. Information published by TI regarding third-party products or services does not constitute a license from TI to use such products or services or a warranty or endorsement thereof. Use of such information may require a license from a third party under the patents or other intellectual property of the third party, or a license from TI under the patents or other intellectual property of TI.

Reproduction of information in TI data books or data sheets is permissible only if reproduction is without alteration and is accompanied by all associated warranties, conditions, limitations, and notices. Reproduction of this information with alteration is an unfair and deceptive business practice. TI is not responsible or liable for such altered documentation.

Resale of TI products or services with statements different from or beyond the parameters stated by TI for that product or service voids all express and any implied warranties for the associated TI product or service and is an unfair and deceptive business practice. TI is not responsible or liable for any such statements.

Following are URLs where you can obtain information on other Texas Instruments products and application solutions:

Products		Applications	
Amplifiers	amplifier.ti.com	Audio	www.ti.com/audio
Data Converters	dataconverter.ti.com	Automotive	www.ti.com/automotive
DSP	dsp.ti.com	Broadband	www.ti.com/broadband
Interface	interface.ti.com	Digital Control	www.ti.com/digitalcontrol
Logic	logic.ti.com	Military	www.ti.com/military
Power Mgmt	power.ti.com	Optical Networking	www.ti.com/opticalnetwork
Microcontrollers	microcontroller.ti.com	Security	www.ti.com/security
		Telephony	www.ti.com/telephony
		Video & Imaging	www.ti.com/video
		Wireless	www.ti.com/wireless

Mailing Address: Texas Instruments
Post Office Box 655303 Dallas, Texas 75265