

# SN75471 THRU SN75473 DUAL PERIPHERAL DRIVERS

SLRS024 – DECEMBER 1976 – REVISED MAY 1990

## PERIPHERAL DRIVERS FOR HIGH-VOLTAGE HIGH-CURRENT DRIVER APPLICATIONS

- Characterized for Use to 300 mA
- High-Voltage Outputs
- No Output Latch-Up at 55 V (After Conducting 300 mA)
- Medium-Speed Switching
- Circuit Flexibility for Varied Applications and Choice of Logic Function
- TTL-Compatible Diode-Clamped Inputs
- Standard Supply Voltages
- Plastic DIP (P) With Copper Lead Frame Provides Cooler Operation and Improved Reliability

### D OR P PACKAGE (TOP VIEW)

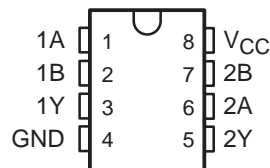

### SUMMARY OF SERIES SN75471

DEVICE	LOGIC OF COMPLETE CIRCUIT	PACKAGES
SN75471	AND	D, P
SN75472	NAND	D, P
SN75473	OR	D, P

## description

Series SN75471 dual peripheral drivers are functionally interchangeable with series SN75451B and series SN75461 peripheral drivers, but are designed for use in systems that require higher breakdown voltages than either of those series can provide at the expense of slightly slower switching speeds than series 75451B (limits are the same as series SN75461). Typical applications include high-speed logic buffers, power drivers, relay drivers, lamp drivers, MOS drivers, line drivers, and memory drivers.

The SN75471, SN75472, and SN75473 are dual peripheral AND, NAND, and OR drivers, respectively, (assuming positive logic), with the output of the logic gates internally connected to the bases of the npn output transistors.

Series SN75471 drivers are characterized for operation from 0°C to 70°C.

# SN75471 THRU SN75473 DUAL PERIPHERAL DRIVERS

SLRS024 – DECEMBER 1976 – REVISED MAY 1990

## absolute maximum ratings over operating free-air temperature range (unless otherwise noted)

Supply voltage, $V_{CC}$ (see Note 1)	7 V
Input voltage, $V_I$	5.5 V
Inter-emitter voltage (see Note 2)	5.5 V
Off-state output voltage, $V_O$	70 V
Continuous collector or output current (see Note 3)	400 mA
Peak collector or output current ( $t_w \leq 10$ ms, duty cycle $\leq 50\%$ , see Note 3)	500 mA
Continuous total power dissipation	See Dissipation Rating Table
Operating free-air temperature range, $T_A$	0°C to 70°C
Storage temperature range, $T_{stg}$	-65°C to 150°C
Lead temperature 1,6 mm (1/16 inch) from case for 10 seconds	260°C

- NOTES: 1. Voltage values are with respect to the network GND, unless otherwise specified.  
 2. This is the voltage between two emitters, A and B.  
 3. Both halves of these dual circuits may conduct rated current simultaneously; however, power dissipation averaged over a short time interval must fall within the continuous dissipation rating.

DISSIPATION RATING TABLE

PACKAGE	$T_A \leq 25^\circ\text{C}$ POWER RATING	DERATING FACTOR ABOVE $T_A = 25^\circ\text{C}$	$T_A = 70^\circ\text{C}$ POWER RATING
D	725 mW	5.8 mW/°C	464 mW
P	1000 mW	8.0 mW/°C	640 mW

## recommended operating conditions

	MIN	NOM	MAX	UNIT
Supply voltage, $V_{CC}$	4.75	5	5.25	V
High-level input voltage, $V_{IH}$	2			V
Low-level input voltage, $V_{IL}$			0.8	V
Operating free-air temperature, $T_A$	0		70	°C



# SN75471 THRU SN75473 DUAL PERIPHERAL DRIVERS

SLRS024 – DECEMBER 1976 – REVISED MAY 1990

## logic symbol†

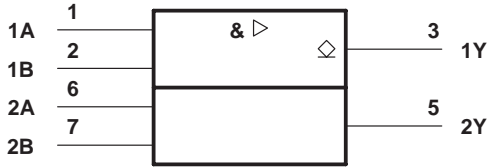

† This symbol is in accordance with ANSI/IEEE Std 91-1984 and IEC Publication 617-12.

## logic diagram (positive logic)

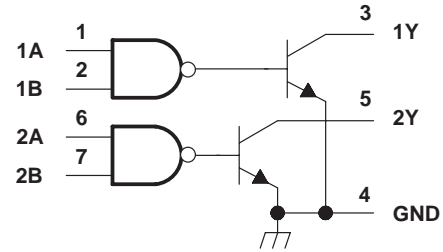

**SN75471 FUNCTION TABLE**  
(each driver)

A	B	Y
L	L	L (on state)
L	H	L (on state)
H	L	L (on state)
H	H	H (off state)

positive logic:  
 $Y = AB$  or  $\bar{A} + \bar{B}$

**SN75471 schematic (each driver)**

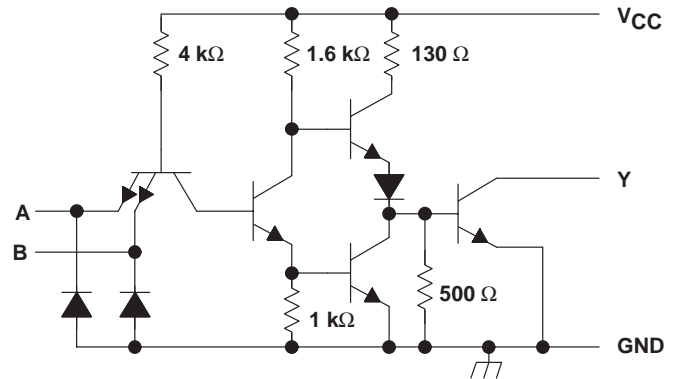

Resistor values shown are nominal.

## electrical characteristics over recommended operating free-air temperature range

PARAMETER	TEST CONDITIONS	SN75471			UNIT
		MIN	TYP‡	MAX	
$V_{IK}$ Input clamp voltage	$V_{CC} = 4.75$ V, $I_I = -12$ mA	-1.2	-1.5		V
$I_{OH}$ High-level output current	$V_{CC} = 4.75$ V, $V_{IH} = 2$ V, $V_{OH} = 70$ V			100	$\mu$ A
$V_{OL}$ Low-level output voltage	$V_{CC} = 4.75$ V, $V_{IL} = 0.8$ V, $I_{OL} = 100$ mA		0.25	0.4	V
	$V_{CC} = 4.75$ V, $V_{IL} = 0.8$ V, $I_{OL} = 300$ mA		0.5	0.7	
$I_I$ Input current at maximum input voltage	$V_{CC} = 5.25$ V, $V_I = 5.5$ V			1	mA
$I_{IH}$ High-level input current	$V_{CC} = 5.25$ V, $V_I = 2.4$ V			40	$\mu$ A
$I_{IL}$ Low-level input current	$V_{CC} = 5.25$ V, $V_I = 0.4$ V		-1	-1.6	mA
$I_{CCH}$ Supply current, outputs high	$V_{CC} = 5.25$ V, $V_I = 5$ V		7	11	mA
$I_{CCL}$ Supply current, outputs low	$V_{CC} = 5.25$ V, $V_I = 0$		52	65	mA

‡ All typical values are at  $V_{CC} = 5$  V,  $T_A = 25^\circ\text{C}$ .

## switching characteristics, $V_{CC} = 5$ V, $T_A = 25^\circ\text{C}$

PARAMETER	TEST CONDITIONS	SN75471			UNIT
		MIN	TYP	MAX	
$t_{PLH}$ Propagation delay time, low-to-high-level output	$I_O \approx 200$ mA, $C_L = 15$ pF, $R_L = 50$ $\Omega$ , See Figure 1		30	55	ns
$t_{PHL}$ Propagation delay time, high-to-low-level output			25	40	
$t_{TLH}$ Transition time, low-to-high-level output			8	20	
$t_{THL}$ Transition time, high-to-low-level output			10	20	
$V_{OH}$ High-level output voltage after switching	$V_S = 55$ V, $I_O \approx 300$ mA, See Figure 2	$V_S - 18$			mV

# SN75471 THRU SN75473 DUAL PERIPHERAL DRIVERS

SLRS024 – DECEMBER 1976 – REVISED MAY 1990

## logic symbol†



† This symbol is in accordance with ANSI/IEEE Std 91-1984 and IEC Publication 617-12.

## logic diagram (positive logic)

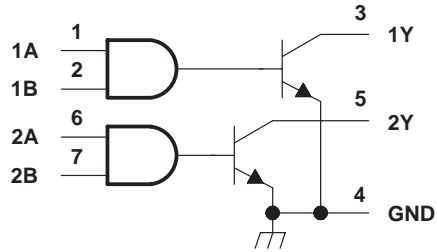

**SN75472 FUNCTION TABLE  
(each driver)**

A	B	Y
L	L	H (off state)
L	H	H (off state)
H	L	H (off state)
H	H	L (on state)

positive logic:  
 $Y = \overline{AB}$  or  $\overline{A + B}$

**SN75472 schematic (each driver)**

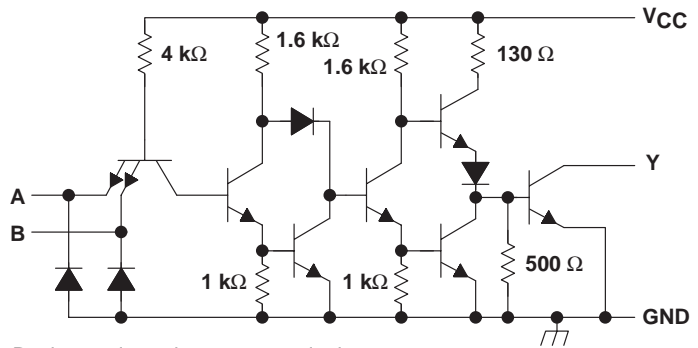

Resistor values shown are nominal.

## electrical characteristics over recommended operating free-air temperature range

PARAMETER	TEST CONDITIONS	SN75472			UNIT
		MIN	TYP‡	MAX	
V <sub>IK</sub> Input clamp voltage	V <sub>CC</sub> = 4.75 V, I <sub>I</sub> = -12 mA	-1.2	-1.5		V
I <sub>OH</sub> High-level output current	V <sub>CC</sub> = 4.75 V, V <sub>IH</sub> = 2 V, V <sub>OH</sub> = 70 V			100	μA
V <sub>OL</sub> Low-level output voltage	V <sub>CC</sub> = 4.75 V, V <sub>IL</sub> = 0.8 V, I <sub>OL</sub> = 100 mA	0.25	0.4		V
	V <sub>CC</sub> = 4.75 V, V <sub>IL</sub> = 0.8 V, I <sub>OL</sub> = 300 mA	0.5	0.7		
I <sub>I</sub> Input current at maximum input voltage	V <sub>CC</sub> = 5.25 V, V <sub>I</sub> = 5.5 V			1	mA
I <sub>IH</sub> High-level input current	V <sub>CC</sub> = 5.25 V, V <sub>I</sub> = 2.4 V			40	μA
I <sub>IL</sub> Low-level input current	V <sub>CC</sub> = 5.25 V, V <sub>I</sub> = 0.4 V	-1	-1.6		mA
I <sub>CCH</sub> Supply current, outputs high	V <sub>CC</sub> = 5.25 V, V <sub>I</sub> = 5 V		13	17	mA
I <sub>CCL</sub> Supply current, outputs low	V <sub>CC</sub> = 5.25 V, V <sub>I</sub> = 0		61	76	mA

‡ All typical values are at V<sub>CC</sub> = 5 V, T<sub>A</sub> = 25°C.

## switching characteristics, V<sub>CC</sub> = 5 V, T<sub>A</sub> = 25°C

PARAMETER	TEST CONDITIONS	SN75472			UNIT
		MIN	TYP	MAX	
t <sub>PLH</sub> Propagation delay time, low-to-high-level output	I <sub>O</sub> ≈ 200 mA, C <sub>L</sub> = 15 pF, R <sub>L</sub> = 50 Ω, See Figure 1		45	65	ns
t <sub>PHL</sub> Propagation delay time, high-to-low-level output			30	50	
t <sub>TLH</sub> Transition time, low-to-high-level output			13	25	
t <sub>THL</sub> Transition time, high-to-low-level output			10	20	
V <sub>OH</sub> High-level output voltage after switching	V <sub>S</sub> = 55 V, I <sub>O</sub> ≈ 300 mA, See Figure 2	V <sub>S</sub> -18			mV

## logic symbol†

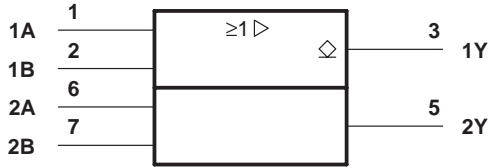

† This symbol is in accordance with ANSI/IEEE Std 91-1984 and IEC Publication 617-12.

## logic diagram (positive logic)

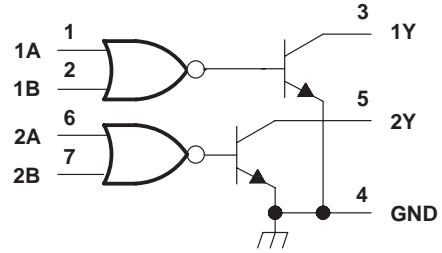

**FUNCTION TABLE**  
(each driver)

A	B	Y
L	L	L (on state)
L	H	H (off state)
H	L	H (off state)
H	H	H (off state)

positive logic:  
 $Y = A + B$  or  $\overline{A} \overline{B}$

**schematic (each driver)**

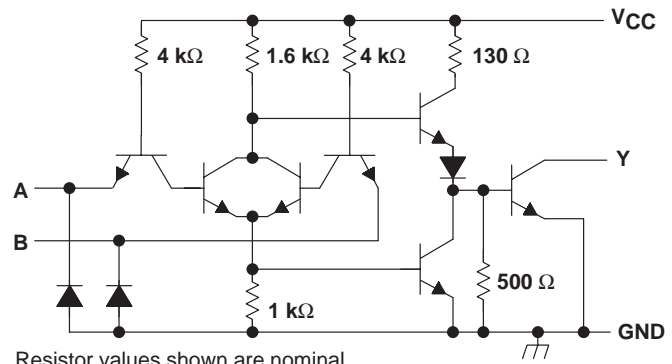

Resistor values shown are nominal.

## electrical characteristics over recommended operating free-air temperature range

PARAMETER	TEST CONDITIONS	SN75473			UNIT
		MIN	TYP‡	MAX	
$V_{IK}$ Input clamp voltage	$V_{CC} = 4.75 \text{ V}$ , $I_I = -12 \text{ mA}$	-1.2	-1.5		V
$I_{OH}$ High-level output current	$V_{CC} = 4.75 \text{ V}$ , $V_{IH} = 2 \text{ V}$ , $V_{OH} = 70 \text{ V}$			100	$\mu\text{A}$
$V_{OL}$ Low-level output voltage	$V_{CC} = 4.75 \text{ V}$ , $V_{IL} = 0.8 \text{ V}$ , $I_{OL} = 100 \text{ mA}$	0.25	0.4		V
	$V_{CC} = 4.75 \text{ V}$ , $V_{IL} = 0.8 \text{ V}$ , $I_{OL} = 300 \text{ mA}$	0.5	0.7		
$I_I$ Input current at maximum input voltage	$V_{CC} = 5.25 \text{ V}$ , $V_I = 5.5 \text{ V}$			1	mA
$I_{IH}$ High-level input current	$V_{CC} = 5.25 \text{ V}$ , $V_I = 2.4 \text{ V}$			40	$\mu\text{A}$
$I_{IL}$ Low-level input current	$V_{CC} = 5.25 \text{ V}$ , $V_I = 0.4 \text{ V}$	-1	-1.6		mA
$I_{CCH}$ Supply current, outputs high	$V_{CC} = 5.25 \text{ V}$ , $V_I = 5 \text{ V}$	8	11		mA
$I_{CCL}$ Supply current, outputs low	$V_{CC} = 5.25 \text{ V}$ , $V_I = 0$	58	76		mA

‡ All typical values are at  $V_{CC} = 5 \text{ V}$ ,  $T_A = 25^\circ\text{C}$ .

## switching characteristics, $V_{CC} = 5 \text{ V}$ , $T_A = 25^\circ\text{C}$

PARAMETER	TEST CONDITIONS	SN75473			UNIT
		MIN	TYP	MAX	
$t_{PLH}$ Propagation delay time, low-to-high-level output	$I_O \approx 200 \text{ mA}$ , $C_L = 15 \text{ pF}$ , $R_L = 50 \Omega$ , See Figure 1		30	55	ns
$t_{PHL}$ Propagation delay time, high-to-low-level output			25	40	
$t_{TLH}$ Transition time, low-to-high-level output			8	25	
$t_{THL}$ Transition time, high-to-low-level output			10	25	
$V_{OH}$ High-level output voltage after switching	$V_S = 55 \text{ V}$ , See Figure 2	$I_O \approx 300 \text{ mA}$ ,	$V_S - 18$		mV

# SN75471 THRU SN75473 DUAL PERIPHERAL DRIVERS

SLRS024 – DECEMBER 1976 – REVISED MAY 1990

## PARAMETER MEASUREMENT INFORMATION

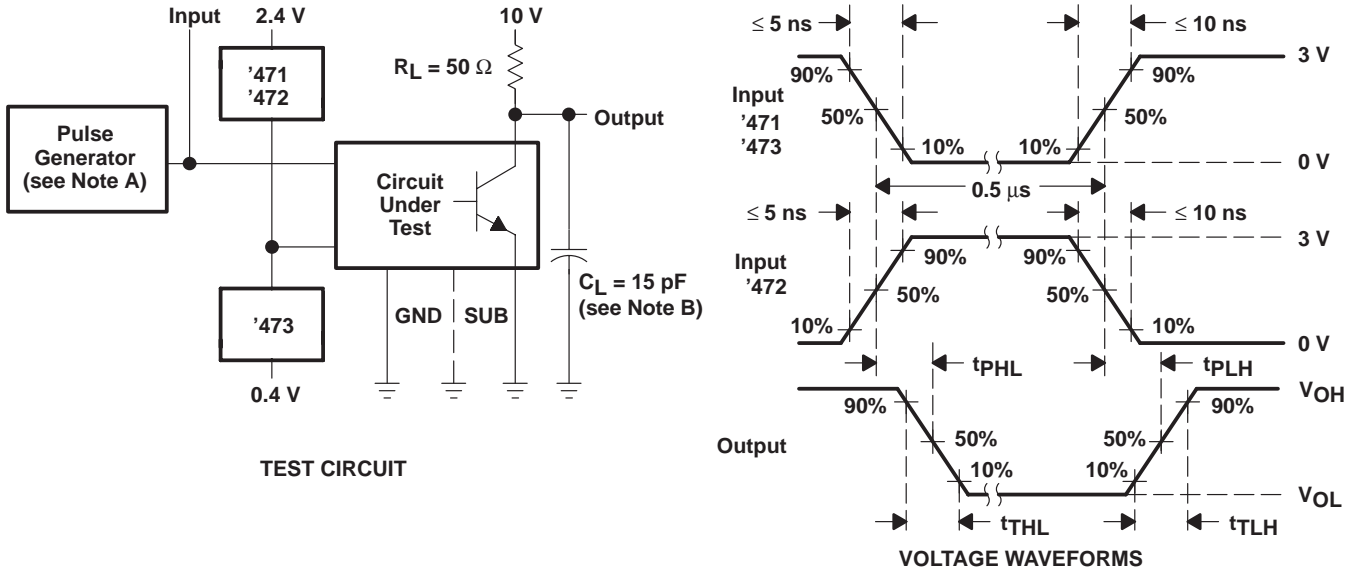

NOTES: A. The pulse generator has the following characteristics:  $\text{PRR} \leq 1 \text{ MHz}$ ,  $Z_O \approx 50 \Omega$ .  
 B.  $C_L$  includes probe and jig capacitance.

Figure 1. Switching Times

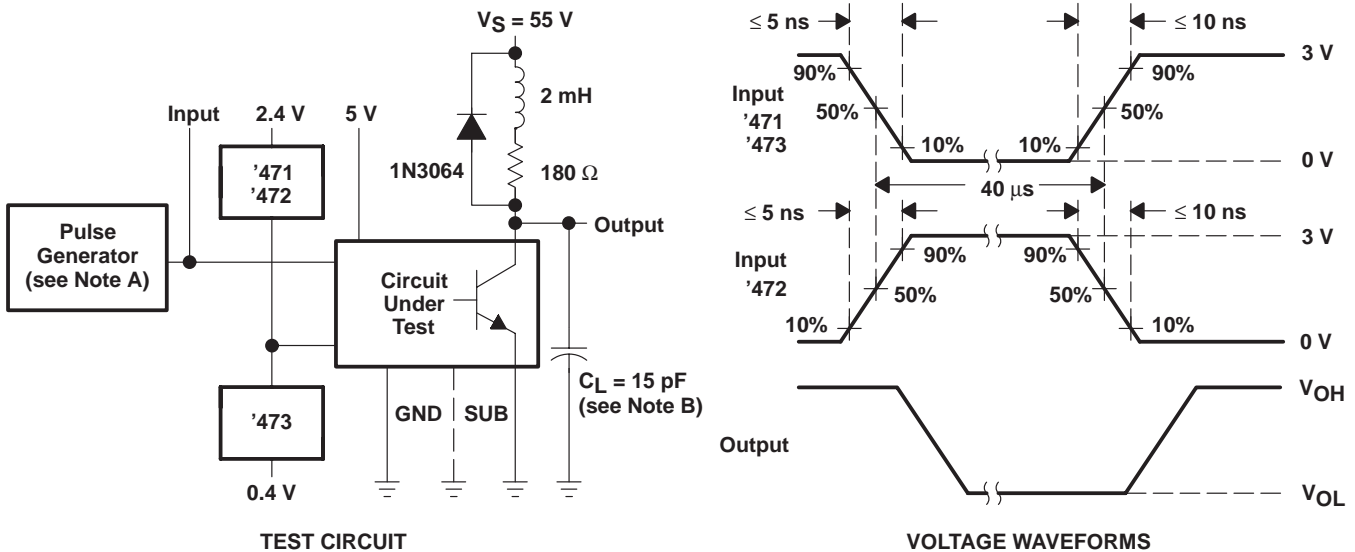

NOTES: A. The pulse generator has the following characteristics:  $\text{PRR} \leq 12.5 \text{ kHz}$ ,  $Z_O \approx 50 \Omega$ .  
 B.  $C_L$  includes probe and jig capacitance.

Figure 2. Latch-Up Test

**PACKAGING INFORMATION**

Orderable Device	Status <sup>(1)</sup>	Package Type	Package Drawing	Pins	Package Qty	Eco Plan <sup>(2)</sup>	Lead/Ball Finish	MSL Peak Temp <sup>(3)</sup>
SN75471D	ACTIVE	SOIC	D	8	75	Pb-Free (RoHS)	CU NIPDAU	Level-2-260C-1 YEAR/ Level-1-235C-UNLIM
SN75471DR	ACTIVE	SOIC	D	8	2500	Pb-Free (RoHS)	CU NIPDAU	Level-2-260C-1 YEAR/ Level-1-235C-UNLIM
SN75471P	ACTIVE	PDIP	P	8	50	Pb-Free (RoHS)	CU NIPDAU	Level-NC-NC-NC
SN75472D	ACTIVE	SOIC	D	8	75	Pb-Free (RoHS)	CU NIPDAU	Level-2-250C-1 YEAR
SN75472P	ACTIVE	PDIP	P	8	50	Pb-Free (RoHS)	CU NIPDAU	Level-NC-NC-NC
SN75473D	OBSOLETE	SOIC	D	8		None	Call TI	Call TI
SN75473P	OBSOLETE	PDIP	P	8		None	Call TI	Call TI

<sup>(1)</sup> The marketing status values are defined as follows:

**ACTIVE:** Product device recommended for new designs.

**LIFEBUY:** TI has announced that the device will be discontinued, and a lifetime-buy period is in effect.

**NRND:** Not recommended for new designs. Device is in production to support existing customers, but TI does not recommend using this part in a new design.

**PREVIEW:** Device has been announced but is not in production. Samples may or may not be available.

**OBSOLETE:** TI has discontinued the production of the device.

<sup>(2)</sup> Eco Plan - May not be currently available - please check <http://www.ti.com/productcontent> for the latest availability information and additional product content details.

**None:** Not yet available Lead (Pb-Free).

**Pb-Free (RoHS):** TI's terms "Lead-Free" or "Pb-Free" mean semiconductor products that are compatible with the current RoHS requirements for all 6 substances, including the requirement that lead not exceed 0.1% by weight in homogeneous materials. Where designed to be soldered at high temperatures, TI Pb-Free products are suitable for use in specified lead-free processes.

**Green (RoHS & no Sb/Br):** TI defines "Green" to mean "Pb-Free" and in addition, uses package materials that do not contain halogens, including bromine (Br) or antimony (Sb) above 0.1% of total product weight.

<sup>(3)</sup> MSL, Peak Temp. -- The Moisture Sensitivity Level rating according to the JEDEC industry standard classifications, and peak solder temperature.

**Important Information and Disclaimer:**The information provided on this page represents TI's knowledge and belief as of the date that it is provided. TI bases its knowledge and belief on information provided by third parties, and makes no representation or warranty as to the accuracy of such information. Efforts are underway to better integrate information from third parties. TI has taken and continues to take reasonable steps to provide representative and accurate information but may not have conducted destructive testing or chemical analysis on incoming materials and chemicals. TI and TI suppliers consider certain information to be proprietary, and thus CAS numbers and other limited information may not be available for release.

In no event shall TI's liability arising out of such information exceed the total purchase price of the TI part(s) at issue in this document sold by TI to Customer on an annual basis.

P (R-PDIP-T8)

PLASTIC DUAL-IN-LINE

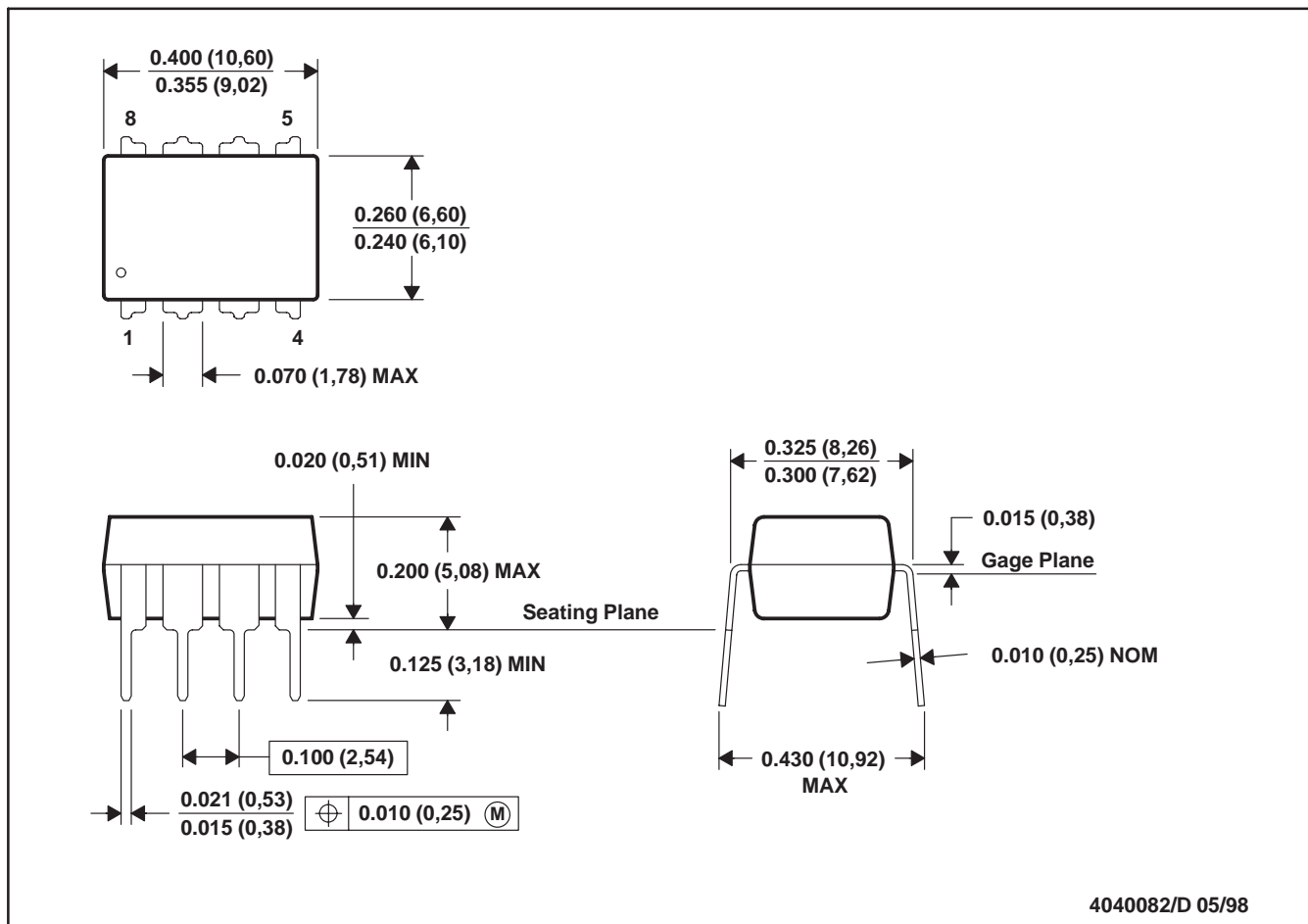

- NOTES: A. All linear dimensions are in inches (millimeters).  
 B. This drawing is subject to change without notice.  
 C. Falls within JEDEC MS-001

For the latest package information, go to [http://www.ti.com/sc/docs/package/pkg\\_info.htm](http://www.ti.com/sc/docs/package/pkg_info.htm)



D (R-PDSO-G8)

PLASTIC SMALL-OUTLINE PACKAGE

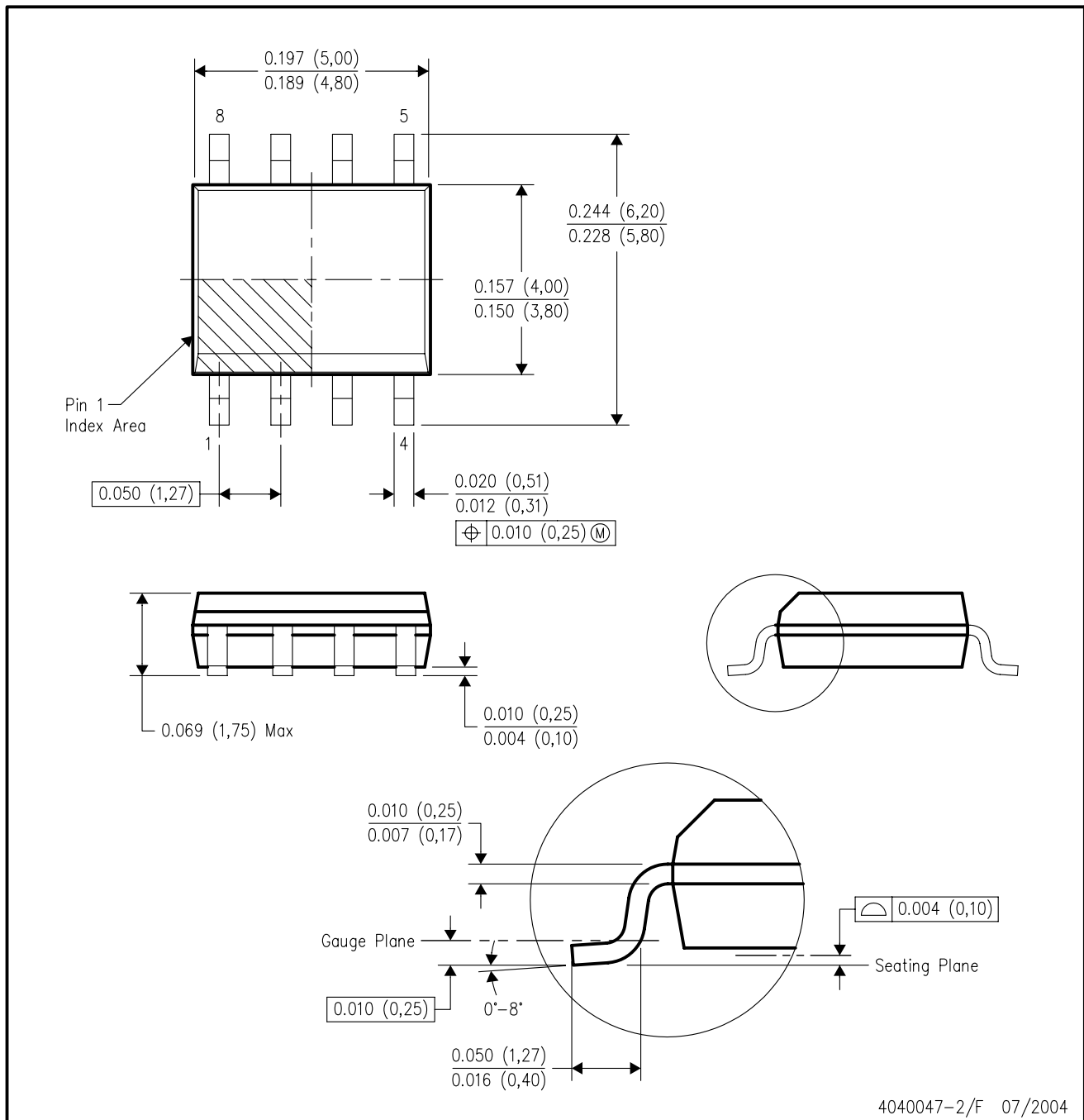

- NOTES:
- A. All linear dimensions are in inches (millimeters).
  - B. This drawing is subject to change without notice.
  - C. Body dimensions do not include mold flash or protrusion not to exceed 0.006 (0,15).
  - D. Falls within JEDEC MS-012 variation AA.

## IMPORTANT NOTICE

Texas Instruments Incorporated and its subsidiaries (TI) reserve the right to make corrections, modifications, enhancements, improvements, and other changes to its products and services at any time and to discontinue any product or service without notice. Customers should obtain the latest relevant information before placing orders and should verify that such information is current and complete. All products are sold subject to TI's terms and conditions of sale supplied at the time of order acknowledgment.

TI warrants performance of its hardware products to the specifications applicable at the time of sale in accordance with TI's standard warranty. Testing and other quality control techniques are used to the extent TI deems necessary to support this warranty. Except where mandated by government requirements, testing of all parameters of each product is not necessarily performed.

TI assumes no liability for applications assistance or customer product design. Customers are responsible for their products and applications using TI components. To minimize the risks associated with customer products and applications, customers should provide adequate design and operating safeguards.

TI does not warrant or represent that any license, either express or implied, is granted under any TI patent right, copyright, mask work right, or other TI intellectual property right relating to any combination, machine, or process in which TI products or services are used. Information published by TI regarding third-party products or services does not constitute a license from TI to use such products or services or a warranty or endorsement thereof. Use of such information may require a license from a third party under the patents or other intellectual property of the third party, or a license from TI under the patents or other intellectual property of TI.

Reproduction of information in TI data books or data sheets is permissible only if reproduction is without alteration and is accompanied by all associated warranties, conditions, limitations, and notices. Reproduction of this information with alteration is an unfair and deceptive business practice. TI is not responsible or liable for such altered documentation.

Resale of TI products or services with statements different from or beyond the parameters stated by TI for that product or service voids all express and any implied warranties for the associated TI product or service and is an unfair and deceptive business practice. TI is not responsible or liable for any such statements.

Following are URLs where you can obtain information on other Texas Instruments products and application solutions:

<b>Products</b>		<b>Applications</b>	
Amplifiers	<a href="http://amplifier.ti.com">amplifier.ti.com</a>	Audio	<a href="http://www.ti.com/audio">www.ti.com/audio</a>
Data Converters	<a href="http://dataconverter.ti.com">dataconverter.ti.com</a>	Automotive	<a href="http://www.ti.com/automotive">www.ti.com/automotive</a>
DSP	<a href="http://dsp.ti.com">dsp.ti.com</a>	Broadband	<a href="http://www.ti.com/broadband">www.ti.com/broadband</a>
Interface	<a href="http://interface.ti.com">interface.ti.com</a>	Digital Control	<a href="http://www.ti.com/digitalcontrol">www.ti.com/digitalcontrol</a>
Logic	<a href="http://logic.ti.com">logic.ti.com</a>	Military	<a href="http://www.ti.com/military">www.ti.com/military</a>
Power Mgmt	<a href="http://power.ti.com">power.ti.com</a>	Optical Networking	<a href="http://www.ti.com/opticalnetwork">www.ti.com/opticalnetwork</a>
Microcontrollers	<a href="http://microcontroller.ti.com">microcontroller.ti.com</a>	Security	<a href="http://www.ti.com/security">www.ti.com/security</a>
		Telephony	<a href="http://www.ti.com/telephony">www.ti.com/telephony</a>
		Video & Imaging	<a href="http://www.ti.com/video">www.ti.com/video</a>
		Wireless	<a href="http://www.ti.com/wireless">www.ti.com/wireless</a>

Mailing Address: Texas Instruments  
Post Office Box 655303 Dallas, Texas 75265