

SN65C3223, SN75C3223

3-V TO 5.5-V MULTICHANNEL RS-232 COMPATIBLE LINE DRIVER/RECEIVER

SLLS538 – JUNE 2002

- Operate With 3-V to 5.5-V V_{CC} Supply
- Operate up to 1 Mbit/s
- Low Standby Current . . . 1 μ A Typical
- External Capacitors . . . $4 \times 0.1 \mu$ F
- Accept 5-V Logic Input With 3.3-V Supply
- Latch-Up Performance Exceeds 100 mA Per JESD 78, Class II
- RS-232 Bus-Pin ESD Protection Exceeds ± 15 kV Using Human-Body Model (HBM)
- Applications
 - Battery-Powered Systems, PDAs, Notebooks, Laptops, Palmtop PCs, and Hand-Held Equipment

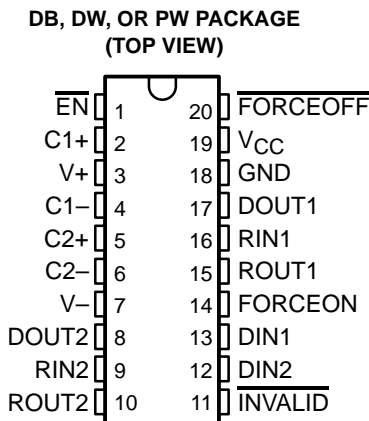

description/ordering information

The SN65C3223 and SN75C3223 consist of two line drivers, two line receivers, and a dual charge-pump circuit with ± 15 -kV ESD protection pin to pin (serial-port connection pins, including GND). The devices provide the electrical interface between an asynchronous communication controller and the serial-port connector. The charge pump and four small external capacitors allow operation from a single 3-V to 5.5-V supply. The devices operate at data signaling rates up to 1 Mbit/s and a driver output slew rate of 24 V/ μ s to 150 V/ μ s

Flexible control options for power management are available when the serial port is inactive. The auto-powerdown feature functions when FORCEON is low and $\overline{\text{FORCEOFF}}$ is high. During this mode of operation, if the device does not sense a valid RS-232 signal, the driver outputs are disabled. If $\overline{\text{FORCEOFF}}$ is set low and $\overline{\text{EN}}$ is high, both drivers and receivers are shut off, and the supply current is reduced to 1 μ A. Disconnecting the serial port or turning off the peripheral drivers causes auto-powerdown to occur. Auto-powerdown can be disabled when FORCEON and $\overline{\text{FORCEOFF}}$ are high. With auto-powerdown enabled, the device is activated automatically when a valid signal is applied to any receiver input. The $\overline{\text{INVALID}}$ output is used to notify the user if an RS-232 signal is present at any receiver input. $\overline{\text{INVALID}}$ is high (valid data) if any receiver input voltage is greater than 2.7 V or less than -2.7 V or has been between -0.3 V and 0.3 V for less than 30 μ s. $\overline{\text{INVALID}}$ is low (invalid data) if the receiver input voltage is between -0.3 V and 0.3 V for more than 30 μ s. Refer to Figure 4 for receiver input levels.

ORDERING INFORMATION

T _A	PACKAGE†	ORDERABLE PART NUMBER	TOP-SIDE MARKING	
–40°C to 85°C	SOIC – DW	Tube	SN65C3223DW	
		Tape and reel	SN65C3223DWR	
	SSOP – DB	Tape and reel	SN65C3223DBR	CB3223
	TSSOP – PW	Tape and reel	SN65C3223PWR	CB3223
0°C to 70°C	SOIC – DW	Tube	SN75C3223DW	
		Tape and reel	SN75C3223DWR	
	SSOP – DB	Tape and reel	SN75C3223DBR	CA3223
	TSSOP – PW	Tape and reel	SN75C3223PWR	CA3223

† Package drawings, standard packing quantities, thermal data, symbolization, and PCB design guidelines are available at www.ti.com/sc/package.



Please be aware that an important notice concerning availability, standard warranty, and use in critical applications of Texas Instruments semiconductor products and disclaimers thereto appears at the end of this data sheet.

PRODUCTION DATA information is current as of publication date. Products conform to specifications per the terms of Texas Instruments standard warranty. Production processing does not necessarily include testing of all parameters.

**TEXAS
INSTRUMENTS**

POST OFFICE BOX 655303 • DALLAS, TEXAS 75265

Copyright © 2002, Texas Instruments Incorporated

SN65C3223, SN75C3223 3-V TO 5.5-V MULTICHANNEL RS-232 COMPATIBLE LINE DRIVER/RECEIVER

SLLS538 – JUNE 2002

Function Tables

EACH DRIVER

INPUTS				OUTPUT DOUT	DRIVER STATUS
DIN	FORCEON	FORCEOFF	VALID RIN RS-232 LEVEL		
X	X	L	X	Z	Powered off
L	H	H	X	H	Normal operation with auto-powerdown disabled
H	H	H	X	L	
L	L	H	Yes	H	Normal operation with auto-powerdown enabled
H	L	H	Yes	L	
L	L	H	No	Z	Powered off by auto-powerdown feature
H	L	H	No	Z	

H = high level, L = low level, X = irrelevant, Z = high impedance

EACH RECEIVER

INPUTS			OUTPUT ROUT
RIN	EN	VALID RIN RS-232 LEVEL	
L	L	X	H
H	L	X	L
X	H	X	Z
Open	L	No	H

H = high level, L = low level, X = irrelevant, Z = high impedance (off), Open = input disconnected or connected driver off

logic diagram (positive logic)

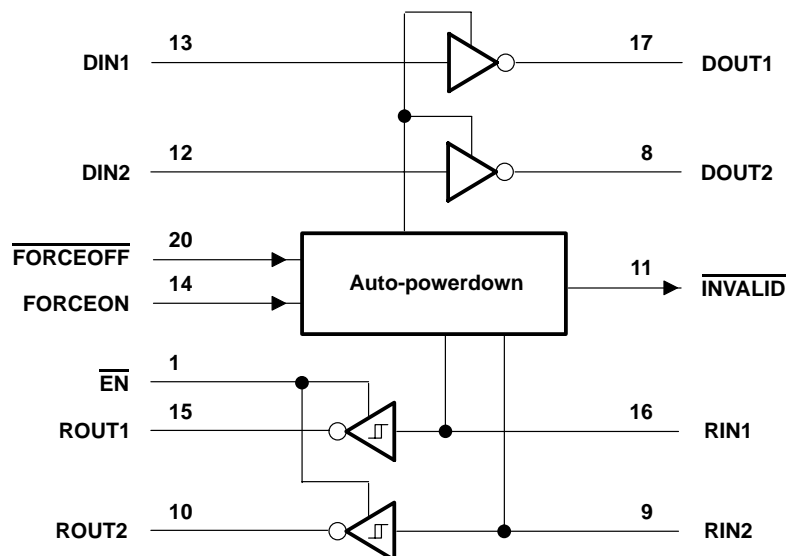

SN65C3223, SN75C3223

3-V TO 5.5-V MULTICHANNEL RS-232 COMPATIBLE LINE DRIVER/RECEIVER

SLLS538 – JUNE 2002

absolute maximum ratings over operating free-air temperature range (unless otherwise noted)†

Supply voltage range, V_{CC} (see Note 1)	–0.3 V to 6 V
Positive output supply voltage range, $V+$ (see Note 1)	–0.3 V to 7 V
Negative output supply voltage range, $V-$ (see Note 1)	0.3 V to –7 V
Supply voltage difference, $V+ - V-$ (see Note 1)	13 V
Input voltage range, V_I : Driver, $\overline{FORCEOFF}$, $FORCEON$, \overline{EN}	–0.3 V to 6 V
Receiver	–25 V to 25 V
Output voltage range, V_O : Driver	–13.2 V to 13.2 V
Receiver, $\overline{INVALID}$	–0.3 V to $V_{CC} + 0.3$ V
Package thermal impedance, θ_{JA} (see Note 2): DB package	70°C/W
DW package	58°C/W
PW package	83°C/W
Lead temperature 1,6 mm (1/16 inch) from case for 10 seconds	260°C
Storage temperature range, T_{stg}	–65°C to 150°C

† Stresses beyond those listed under “absolute maximum ratings” may cause permanent damage to the device. These are stress ratings only, and functional operation of the device at these or any other conditions beyond those indicated under “recommended operating conditions” is not implied. Exposure to absolute-maximum-rated conditions for extended periods may affect device reliability.

- NOTES: 1. All voltages are with respect to network GND.
 2. The package thermal impedance is calculated in accordance with JESD 51-7.

recommended operating conditions (see Note 3 and Figure 6)

			MIN	NOM	MAX	UNIT
V_{CC}	Supply voltage	$V_{CC} = 3.3$ V	3	3.3	3.6	V
		$V_{CC} = 5$ V	4.5	5	5.5	
V_{IH}	Driver and control high-level input voltage	DIN, \overline{EN} , $\overline{FORCEOFF}$, $FORCEON$	$V_{CC} = 3.3$ V	2		V
			$V_{CC} = 5$ V	2.4		
V_{IL}	Driver and control low-level input voltage	DIN, \overline{EN} , $\overline{FORCEOFF}$, $FORCEON$			0.8	V
V_I	Driver and control input voltage	DIN, \overline{EN} , $\overline{FORCEOFF}$, $FORCEON$	0		5.5	V
	Receiver input voltage		–25		25	
T_A	Operating free-air temperature	SN65C3223	–40		85	°C
		SN65C3223	0		70	

NOTE 3: Test conditions are C1–C4 = 0.1 μ F at $V_{CC} = 3.3$ V \pm 0.3 V; C1 = 0.047 μ F, C2–C4 = 0.33 μ F at $V_{CC} = 5$ V \pm 0.5 V.

electrical characteristics over recommended ranges of supply voltage and operating free-air temperature (unless otherwise noted) (see Note 3 and Figure 6)

PARAMETER		TEST CONDITIONS	MIN	TYP‡	MAX	UNIT
I_I	Input leakage current	\overline{EN} , $\overline{FORCEOFF}$, $FORCEON$		± 0.01	± 1	μ A
I_{CC}	Supply current	Auto-powerdown disabled	No load, $\overline{FORCEOFF}$, $FORCEON$ at V_{CC}	0.3	1	mA
		Powered off	No load, $\overline{FORCEOFF}$ at GND	1	10	
		Auto-powerdown enabled	No load, $\overline{FORCEOFF}$ at V_{CC} , $FORCEON$ at GND, All RIN are open or grounded	1	10	μ A

‡ All typical values are at $V_{CC} = 3.3$ V or $V_{CC} = 5$ V, and $T_A = 25^\circ$ C.

NOTE 3: Test conditions are C1–C4 = 0.1 μ F at $V_{CC} = 3.3$ V \pm 0.3 V; C1 = 0.047 μ F, C2–C4 = 0.33 μ F at $V_{CC} = 5$ V \pm 0.5 V.



SN65C3223, SN75C3223
3-V TO 5.5-V MULTICHANNEL RS-232 COMPATIBLE LINE DRIVER/RECEIVER

SLLS538 – JUNE 2002

DRIVER SECTION

electrical characteristics over recommended ranges of supply voltage and operating free-air temperature (unless otherwise noted) (see Note 3 and Figure 6)

PARAMETER	TEST CONDITIONS	MIN	TYP†	MAX	UNIT
V _{OH} High-level output voltage	DOUT at R _L = 3 kΩ to GND	5	5.4		V
V _{OL} Low-level output voltage	DOUT at R _L = 3 kΩ to GND	-5	-5.4		V
I _{IH} High-level input current	V _I = V _{CC}		±0.01	±1	μA
I _{IL} Low-level input current	V _I at GND		±0.01	±1	μA
I _{OS} Short-circuit output current‡	V _{CC} = 3.6 V, V _O = 0 V		±35	±60	mA
	V _{CC} = 5.5 V, V _O = 0 V		±35	±90	
r _o Output resistance	V _{CC} , V+, and V- = 0 V, V _O = ±2 V	300	10M		Ω
I _{off} Output leakage current	FORCEOFF = GND, V _O = ±12 V, V _{CC} = 0 to 5.5 V			±25	μA

† All typical values are at V_{CC} = 3.3 V or V_{CC} = 5 V, and T_A = 25°C.

‡ Short-circuit durations should be controlled to prevent exceeding the device absolute power-dissipation ratings, and not more than one output should be shorted at a time.

NOTE 3: Test conditions are C1–C4 = 0.1 μF at V_{CC} = 3.3 V ± 0.3 V; C1 = 0.047 μF, C2–C4 = 0.33 μF at V_{CC} = 5 V ± 0.5 V.

switching characteristics over recommended ranges of supply voltage and operating free-air temperature (unless otherwise noted) (see Note 3 and Figure 6)

PARAMETER	TEST CONDITIONS	MIN	TYP†	MAX	UNIT
Maximum data rate (see Figure 1)	R _L = 3 kΩ, One DOUT switching	C _L = 1000 pF	250		kbit/s
		C _L = 250 pF, V _{CC} = 3 V to 4.5 V	1000		
		C _L = 1000 pF, V _{CC} = 4.5 V to 5.5 V	1000		
t _{sk(p)} Pulse skew§	C _L = 150 pF to 2500 pF, R _L = 3 kΩ to 7 kΩ, See Figure 2		300		ns
SR(tr) Slew rate, transition region (see Figure 1)	V _{CC} = 3.3 V, R _L = 3 kΩ to 7 kΩ		24	150	V/μs

† All typical values are at V_{CC} = 3.3 V or V_{CC} = 5 V, and T_A = 25°C.

§ Pulse skew is defined as |t_{PLH} - t_{PHL}| of each channel of the same device.

NOTE 3: Test conditions are C1–C4 = 0.1 μF at V_{CC} = 3.3 V ± 0.3 V; C1 = 0.047 μF, C2–C4 = 0.33 μF at V_{CC} = 5 V ± 0.5 V.



RECEIVER SECTION

electrical characteristics over recommended ranges of supply voltage and operating free-air temperature (unless otherwise noted) (see Note 3 and Figure 6)

PARAMETER		TEST CONDITIONS	MIN	TYP†	MAX	UNIT
V _{OH}	High-level output voltage	I _{OH} = -1 mA	V _{CC} -0.6	V _{CC} -0.1		V
V _{OL}	Low-level output voltage	I _{OL} = 1.6 mA			0.4	V
V _{IT+}	Positive-going input threshold voltage	V _{CC} = 3.3 V		1.6	2.4	V
		V _{CC} = 5 V		1.9	2.4	
V _{IT-}	Negative-going input threshold voltage	V _{CC} = 3.3 V	0.6	1.1		V
		V _{CC} = 5 V	0.8	1.4		
V _{hys}	Input hysteresis (V _{IT+} - V _{IT-})			0.5		V
I _{off}	Output leakage current	$\overline{\text{EN}} = V_{\text{CC}}$		±0.05	±10	µA
r _i	Input resistance	V _I = ±3 V to ±25 V	3	5	7	kΩ

† All typical values are at V_{CC} = 3.3 V or V_{CC} = 5 V, and T_A = 25°C.

NOTE 3: Test conditions are C1-C4 = 0.1 µF at V_{CC} = 3.3 V ± 0.3 V; C1 = 0.047 µF, C2-C4 = 0.33 µF at V_{CC} = 5 V ± 0.5 V.

switching characteristics over recommended ranges of supply voltage and operating free-air temperature (unless otherwise noted) (see Note 3)

PARAMETER		TEST CONDITIONS		MIN	TYP†	MAX	UNIT
t _{PLH}	Propagation delay time, low- to high-level output	C _L = 150 pF,	See Figure 3		150		ns
t _{PHL}	Propagation delay time, high- to low-level output	C _L = 150 pF,	See Figure 3		150		ns
t _{en}	Output enable time	C _L = 150 pF, See Figure 4	R _L = 3 kΩ,		200		ns
t _{dis}	Output disable time	C _L = 150 pF, See Figure 4	R _L = 3 kΩ,		200		ns
t _{sk(p)}	Pulse skew‡	See Figure 3			50		ns

† All typical values are at V_{CC} = 3.3 V or V_{CC} = 5 V, and T_A = 25°C.

‡ Pulse skew is defined as |t_{PLH} - t_{PHL}| of each channel of the same device.

NOTE 3: Test conditions are C1-C4 = 0.1 µF at V_{CC} = 3.3 V ± 0.3 V; C1 = 0.047 µF, C2-C4 = 0.33 µF at V_{CC} = 5 V ± 0.5 V.

SN65C3223, SN75C3223 3-V TO 5.5-V MULTICHANNEL RS-232 COMPATIBLE LINE DRIVER/RECEIVER

SLLS538 – JUNE 2002

AUTO-POWERDOWN SECTION

electrical characteristics over recommended ranges of supply voltage and operating free-air temperature (unless otherwise noted) (see Figure 5)

PARAMETER		TEST CONDITIONS	MIN	MAX	UNIT
V _{T+(valid)}	Receiver input threshold for INVALID high-level output voltage	FORCEON = GND, $\overline{\text{FORCEOFF}} = V_{CC}$		2.7	V
V _{T-(valid)}	Receiver input threshold for INVALID high-level output voltage	FORCEON = GND, $\overline{\text{FORCEOFF}} = V_{CC}$	-2.7		V
V _{T(invalid)}	Receiver input threshold for INVALID low-level output voltage	FORCEON = GND, $\overline{\text{FORCEOFF}} = V_{CC}$	-0.3	0.3	V
V _{OH}	$\overline{\text{INVALID}}$ high-level output voltage	I _{OH} = -1 mA, $\overline{\text{FORCEOFF}} = V_{CC}$ FORCEON = GND,	V _{CC} -0.6		V
V _{OL}	$\overline{\text{INVALID}}$ low-level output voltage	I _{OL} = 1.6 mA, $\overline{\text{FORCEOFF}} = V_{CC}$ FORCEON = GND,		0.4	V

switching characteristics over recommended ranges of supply voltage and operating free-air temperature (unless otherwise noted) (see Figure 5)

PARAMETER		TYPT†	UNIT
t _{valid}	Propagation delay time, low- to high-level output	1	μs
t _{invalid}	Propagation delay time, high- to low-level output	30	μs
t _{en}	Supply enable time	100	μs

† All typical values are at V_{CC} = 3.3 V or V_{CC} = 5 V, and T_A = 25°C.

PARAMETER MEASUREMENT INFORMATION

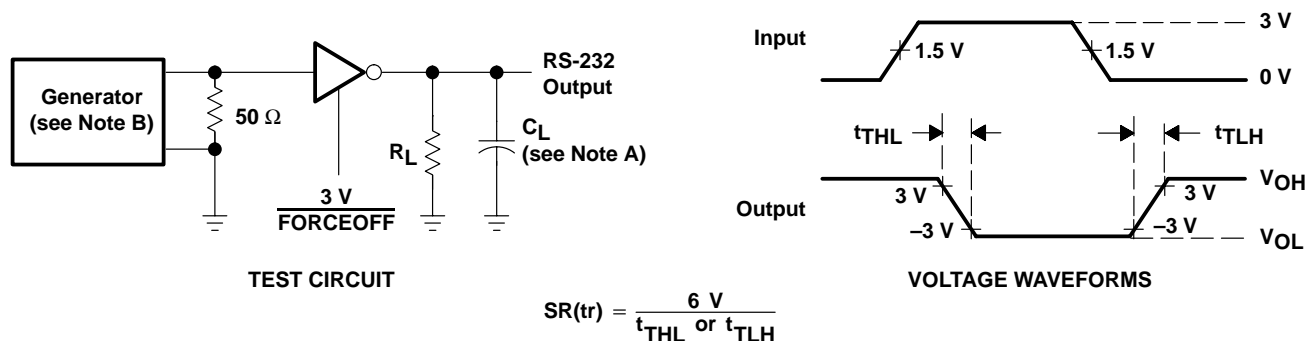

NOTES: A. C_L includes probe and jig capacitance.

B. The pulse generator has the following characteristics: PRR = 250 kbit/s, Z_O = 50 Ω, 50% duty cycle, t_r ≤ 10 ns, t_f ≤ 10 ns.

Figure 1. Driver Slew Rate

PARAMETER MEASUREMENT INFORMATION

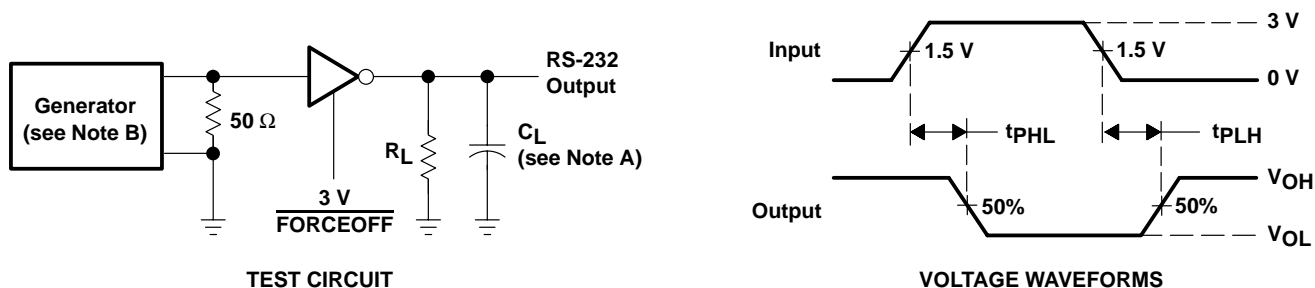

NOTES: A. C_L includes probe and jig capacitance.
B. The pulse generator has the following characteristics: PRR = 250 kbit/s, $Z_O = 50 \Omega$, 50% duty cycle, $t_r \leq 10$ ns, $t_f \leq 10$ ns.

Figure 2. Driver Pulse Skew

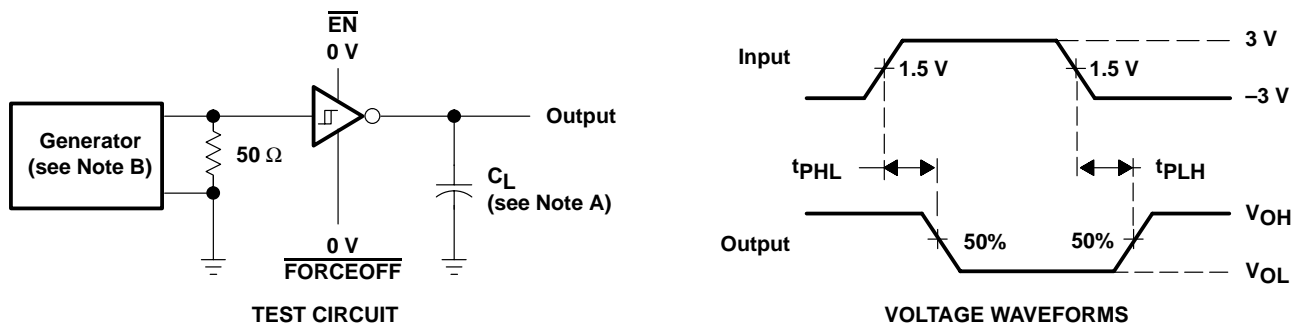

NOTES: A. C_L includes probe and jig capacitance.
B. The pulse generator has the following characteristics: $Z_O = 50 \Omega$, 50% duty cycle, $t_r \leq 10$ ns, $t_f \leq 10$ ns.

Figure 3. Receiver Propagation Delay Times

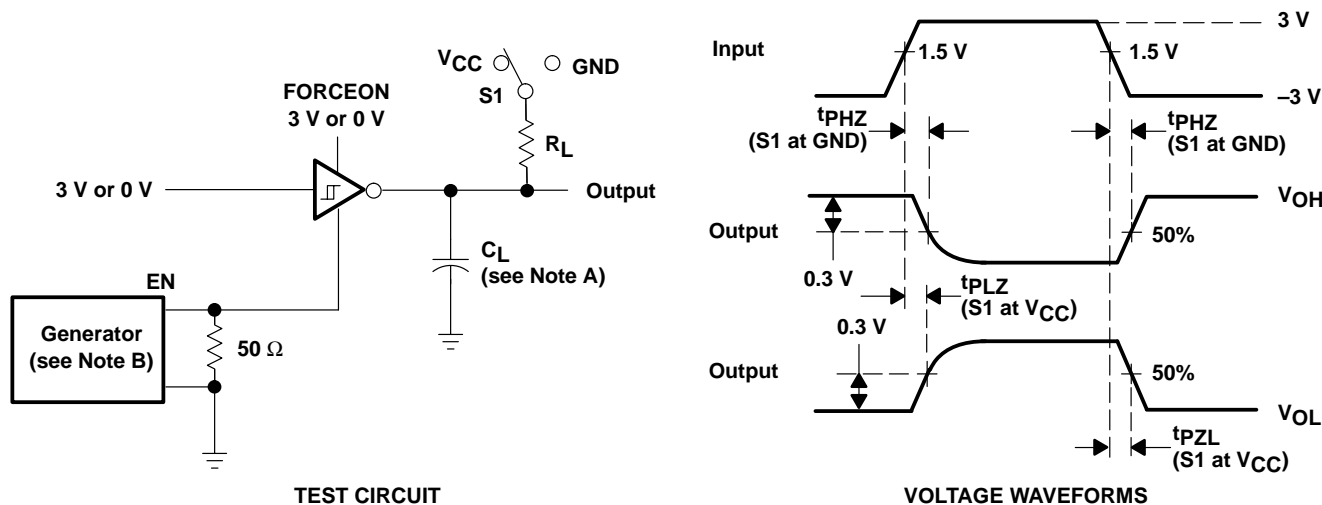

NOTES: A. C_L includes probe and jig capacitance.
B. The pulse generator has the following characteristics: $Z_O = 50 \Omega$, 50% duty cycle, $t_r \leq 10$ ns, $t_f \leq 10$ ns.

Figure 4. Receiver Enable and Disable Times

SN65C3223, SN75C3223
3-V TO 5.5-V MULTICHANNEL RS-232 COMPATIBLE LINE DRIVER/RECEIVER

SLLS538 – JUNE 2002

PARAMETER MEASUREMENT INFORMATION

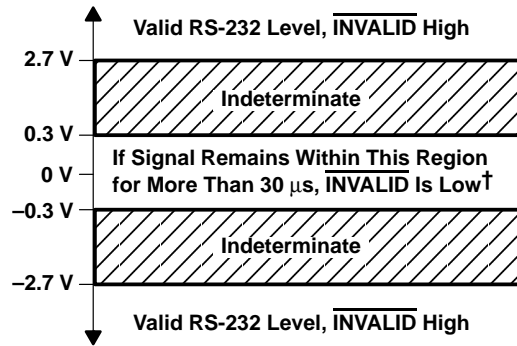
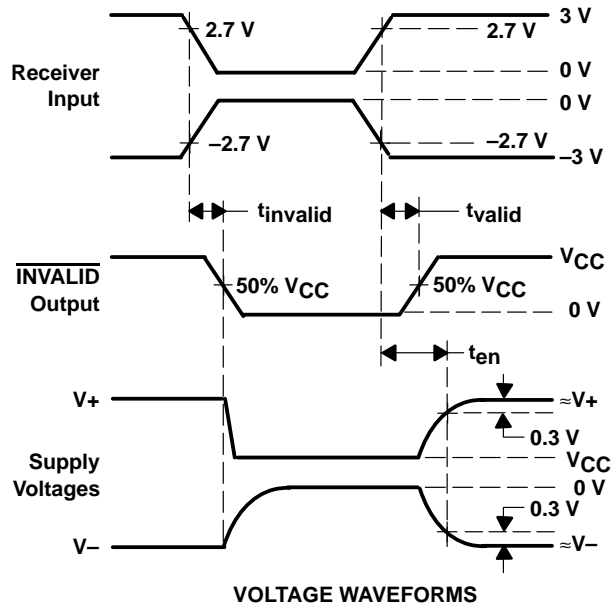
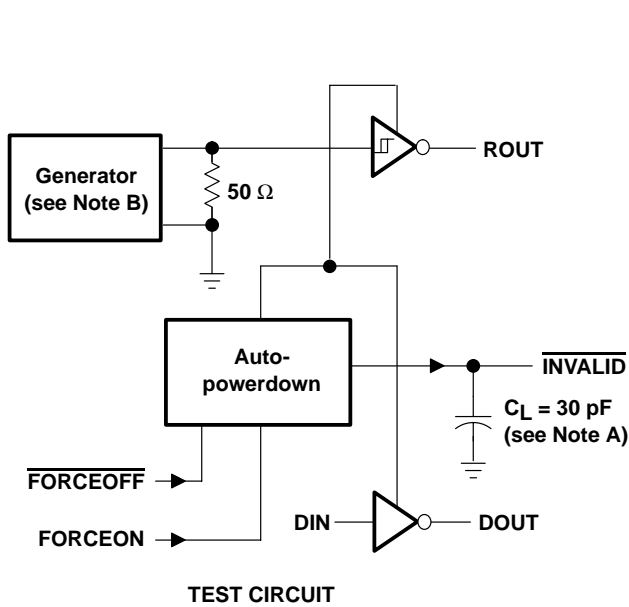

[†] Auto-powerdown disables drivers and reduces supply current to 1 μA .

- NOTES: A. C_L includes probe and jig capacitance.
 B. The pulse generator has the following characteristics: PRR = 5 kbit/s, $Z_0 = 50 \Omega$, 50% duty cycle, $t_r \leq 10 \text{ ns}$, $t_f \leq 10 \text{ ns}$.

Figure 5. $\overline{\text{INVALID}}$ Propagation Delay Times and Supply Enabling Time

APPLICATION INFORMATION

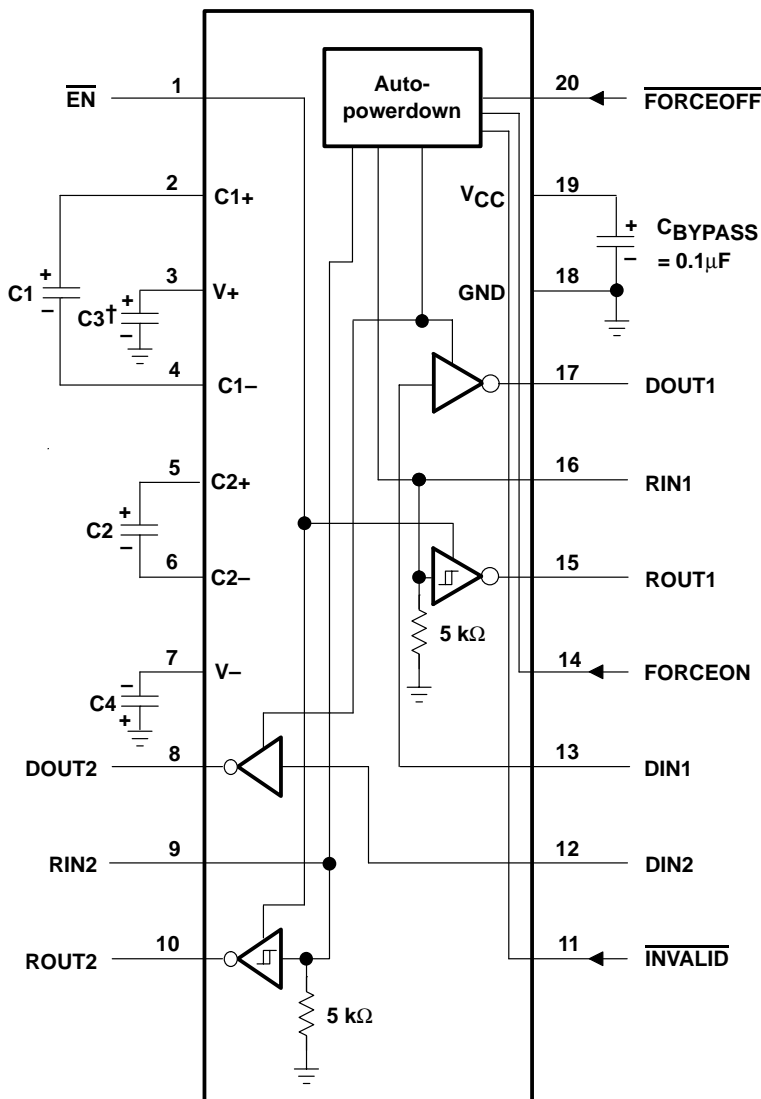

† C3 can be connected to V_{CC} or GND.
NOTE A: Resistor values shown are nominal.

V_{CC} vs CAPACITOR VALUES

V _{CC}	C1	C2, C3, C4
3.3 V ± 0.3 V	0.1 μF	0.1 μF
5 V ± 0.5 V	0.047 μF	0.33 μF
3 V to 5.5 V	0.1 μF	0.47 μF

Figure 6. Typical Operating Circuit and Capacitor Values

IMPORTANT NOTICE

Texas Instruments Incorporated and its subsidiaries (TI) reserve the right to make corrections, modifications, enhancements, improvements, and other changes to its products and services at any time and to discontinue any product or service without notice. Customers should obtain the latest relevant information before placing orders and should verify that such information is current and complete. All products are sold subject to TI's terms and conditions of sale supplied at the time of order acknowledgment.

TI warrants performance of its hardware products to the specifications applicable at the time of sale in accordance with TI's standard warranty. Testing and other quality control techniques are used to the extent TI deems necessary to support this warranty. Except where mandated by government requirements, testing of all parameters of each product is not necessarily performed.

TI assumes no liability for applications assistance or customer product design. Customers are responsible for their products and applications using TI components. To minimize the risks associated with customer products and applications, customers should provide adequate design and operating safeguards.

TI does not warrant or represent that any license, either express or implied, is granted under any TI patent right, copyright, mask work right, or other TI intellectual property right relating to any combination, machine, or process in which TI products or services are used. Information published by TI regarding third-party products or services does not constitute a license from TI to use such products or services or a warranty or endorsement thereof. Use of such information may require a license from a third party under the patents or other intellectual property of the third party, or a license from TI under the patents or other intellectual property of TI.

Reproduction of information in TI data books or data sheets is permissible only if reproduction is without alteration and is accompanied by all associated warranties, conditions, limitations, and notices. Reproduction of this information with alteration is an unfair and deceptive business practice. TI is not responsible or liable for such altered documentation.

Resale of TI products or services with statements different from or beyond the parameters stated by TI for that product or service voids all express and any implied warranties for the associated TI product or service and is an unfair and deceptive business practice. TI is not responsible or liable for any such statements.

Mailing Address:

Texas Instruments
Post Office Box 655303
Dallas, Texas 75265