

## FEATURES

- Operate With 3-V to 5.5-V  $V_{CC}$  Supply
- Operate up to 1 Mbit/s
- Low Supply Current . . . 300  $\mu$ A Typ
- External Capacitors . . .  $4 \times 0.1 \mu$ F
- Accept 5-V Logic Input With 3.3-V Supply
- Latch-Up Performance Exceeds 100 mA Per JESD 78, Class II
- ESD Protection for RS-232 Pins
  - ±15-kV Human-Body Model (HBM)
  - ±15-kV IEC 61000-4-2 Air-Gap Discharge
  - ±8-kV IEC 61000-4-2 Contact Discharge

D, DB, DW, OR PW PACKAGE  
(TOP VIEW)

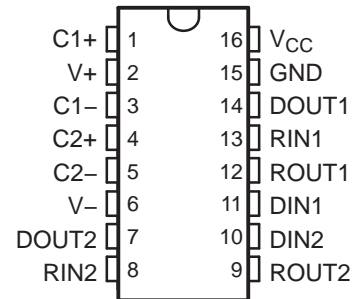

## APPLICATIONS

- Battery-Powered Systems
- PDAs
- Notebooks
- Laptops
- Palmtop PCs
- Hand-Held Equipment

## DESCRIPTION/ORDERING INFORMATION

The SN65C3232E and SN75C3232E consist of two line drivers, two line receivers, and a dual charge-pump circuit with ±15-kV ESD protection pin to pin (serial-port connection pins, including GND). These devices provide the electrical interface between an asynchronous communication controller and the serial-port connector. The charge pump and four small external capacitors allow operation from a single 3-V to 5.5-V supply. The devices operate at data signaling rates up to 1 Mbit/s and a driver output slew rate of 14 V/ $\mu$ s to 150 V/ $\mu$ s.

### ORDERING INFORMATION

$T_A$	PACKAGE <sup>(1)(2)</sup>		ORDERABLE PART NUMBER	TOP-SIDE MARKING
–40°C to 85°C	SOIC – D	Tube of 40	SN65C3232ED	65C3232E
		Reel of 2500	SN65C3232EDR	
	SOIC – DW	Tube of 40	SN65C3232EDW	65C3232E
		Reel of 2000	SN65C3232EDWR	
	SSOP – DB	Reel of 2000	SN65C3232EDBR	MU232E
	TSSOP – PW	Tube of 90	SN65C3232EPW	MU232E
Reel of 2000		SN65C3232EPWR		
0°C to 70°C	SOIC – D	Tube of 40	SN75C3232ED	75C3232E
		Reel of 2500	SN75C3232EDR	
	SOIC – DW	Tube of 40	SN75C3232EDW	75C3232E
		Reel of 2000	SN75C3232EDWR	
	SSOP – DB	Reel of 2000	SN75C3232EDBR	MY232E
	TSSOP – PW	Tube of 90	SN75C3232EPW	MY232E
Reel of 2000		SN75C3232EPWR		

(1) Package drawings, thermal data, and symbolization are available at [www.ti.com/packaging](http://www.ti.com/packaging).

(2) For the most current package and ordering information, see the Package Option Addendum at the end of this document, or see the TI website at [www.ti.com](http://www.ti.com).



Please be aware that an important notice concerning availability, standard warranty, and use in critical applications of Texas Instruments semiconductor products and disclaimers thereto appears at the end of this data sheet.

**SN65C3232E, SN75C3232E**  
**3-V TO 5.5-V TWO-CHANNEL RS-232 1-MBIT/S LINE DRIVERS/RECEIVERS**  
**WITH ±15-kV IEC ESD PROTECTION**

SLLS697A–DECEMBER 2005–REVISED DECEMBER 2007

**Table 1. 1-Mbit/s RS-232 Parts**

TEMPERATURE RANGE	PART NO.	NO. OF DRIVERS	NO. OF RECEIVERS	ESD	SUPPLY V <sub>CC</sub> (V)	FEATURE	PIN/PACKAGE
–40°C to 85°C	SN65C3221E	1	1	±15-kV Air-Gap, ±8-kV Contact, ±15-kV HBM	3.3 or 5	Auto powerdown	16-pin SOIC, SSOP, TSSOP
	SN65C3232E	2	2	±15-kV Air-Gap, ±8-kV Contact, ±15-kV HBM	3.3 or 5	Low pin count	16-pin SOIC, SSOP, TSSOP
	MAX3227I	1	1	±8-kV Air-Gap, ±8-kV Contact, ±15-kV HBM	3.3 or 5	Auto powerdown plus, ready signal	16-pin SSOP
	SN65C3221	1	1	±15-kV HBM	3.3 or 5	Auto powerdown	16-pin SOIC, SSOP, TSSOP
	SN65C3223	2	2	±15-kV HBM	3.3 or 5	Auto powerdown, enable signal	20-pin SOIC, SSOP, TSSOP
	SN65C3222	2	2	±15-kV HBM	3.3 or 5	Enable, powerdown signal	20-pin SOIC, SSOP, TSSOP
	SN65C3232	2	2	±15-kV HBM	3.3 or 5	Low pin count	16-pin SOIC, SSOP, TSSOP
	SN65C3238	5	3	±15-kV HBM	3.3 or 5	Auto powerdown plus	28-pin SOIC, SSOP, TSSOP
	SN65C3243	3	5	±15-kV HBM	3.3 or 5	Auto powerdown	28-pin SOIC, SSOP, TSSOP
0°C to 70°C	SN75C3221E	1	1	±15-kV Air-Gap, ±8-kV Contact, ±15-kV HBM	3.3 or 5	Auto powerdown	16-pin SOIC, SSOP, TSSOP
	SN75C3232E	2	2	±15-kV Air-Gap, ±8-kV Contact, ±15-kV HBM	3.3 or 5	Low pin count	16-pin SOIC, SSOP, TSSOP
	MAX3227C	1	1	±8-kV Air-Gap, ±8-kV Contact, ±15-kV HBM	3.3 or 5	Auto powerdown plus, ready signal	16-pin SSOP
	SN75C3221	1	1	±15-kV HBM	3.3 or 5	Auto powerdown	16-pin SOIC, SSOP, TSSOP
	SN75C3223	2	2	±15-kV HBM	3.5 or 5	Auto powerdown, enable signal	20-pin SOIC, SSOP, TSSOP
	SN75C3222	2	2	±15-kV HBM	3.3 or 5	Enable, powerdown signal	20-pin SOIC, SSOP, TSSOP
	SN75C3232	2	2	±15-kV HBM	3.3 or 5	Low pin count	16-pin SOIC, SSOP, TSSOP
	SN75C3238	5	3	±15-kV HBM	3.3 or 5	Auto powerdown plus	28-pin SOIC, SSOP, TSSOP
	SN75C3243	3	5	±15-kV HBM	3.3 or 5	Auto powerdown	28-pin SOIC, SSOP, TSSOP

**FUNCTION TABLES**

**EACH DRIVER<sup>(1)</sup>**

INPUT DIN	OUTPUT DOUT
L	H
H	L

(1) H = high level, L = low level

**EACH RECEIVER<sup>(1)</sup>**

INPUT RIN	OUTPUT ROUT
L	H
H	L
Open	H

(1) H = high level, L = low level,  
Open = input disconnected or  
connected driver off

**LOGIC DIAGRAM (POSITIVE LOGIC)**

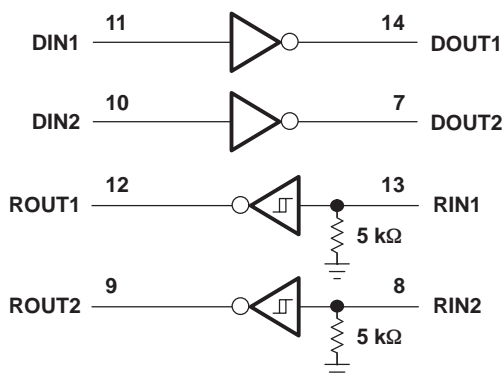

# SN65C3232E, SN75C3232E

## 3-V TO 5.5-V TWO-CHANNEL RS-232 1-MBIT/S LINE DRIVERS/RECEIVERS

### WITH ±15-kV IEC ESD PROTECTION

SLLS697A–DECEMBER 2005–REVISED DECEMBER 2007

### Absolute Maximum Ratings<sup>(1)</sup>

over operating free-air temperature range (unless otherwise noted)

		MIN	MAX	UNIT	
V <sub>CC</sub>	Supply voltage range <sup>(2)</sup>	−0.3	6	V	
V+	Positive output supply voltage range <sup>(2)</sup>	−0.3	7	V	
V−	Negative output supply voltage range <sup>(2)</sup>	0.3	−7	V	
V+ − V−	Supply voltage difference <sup>(2)</sup>		13	V	
V <sub>I</sub>	Input voltage range	Drivers	−0.3	6	V
		Receivers	−25	25	
V <sub>O</sub>	Output voltage range	Drivers	−13.2	13.2	V
		Receivers	−0.3	V <sub>CC</sub> + 0.3	
θ <sub>JA</sub>	Package thermal impedance <sup>(3)(4)</sup>	D package		82	°C/W
		DB package		46	
		DW package		57	
		PW package		108	
T <sub>J</sub>	Operating virtual junction temperature		150	°C	
T <sub>stg</sub>	Storage temperature range	−65	150	°C	

- Stresses beyond those listed under "absolute maximum ratings" may cause permanent damage to the device. These are stress ratings only, and functional operation of the device at these or any other conditions beyond those indicated under "recommended operating conditions" is not implied. Exposure to absolute-maximum-rated conditions for extended periods may affect device reliability.
- All voltages are with respect to network GND.
- Maximum power dissipation is a function of T<sub>J</sub>(max), θ<sub>JA</sub>, and T<sub>A</sub>. The maximum allowable power dissipation at any allowable ambient temperature is P<sub>D</sub> = (T<sub>J</sub>(max) − T<sub>A</sub>)/θ<sub>JA</sub>. Operating at the absolute maximum T<sub>J</sub> of 150°C can affect reliability.
- The package thermal impedance is calculated in accordance with JESD 51-7.

### Recommended Operating Conditions<sup>(1)</sup>

		MIN	NOM	MAX	UNIT	
Supply voltage		V <sub>CC</sub> = 3.3 V	3	3.3	3.6	V
		V <sub>CC</sub> = 5 V	4.5	5	5.5	
V <sub>IH</sub>	Driver high-level input voltage	DIN	V <sub>CC</sub> = 3.3 V	2		V
			V <sub>CC</sub> = 5 V	2.4		
V <sub>IL</sub>	Driver low-level input voltage	DIN		0.8	V	
V <sub>I</sub>	Driver input voltage	DIN	0	5.5	V	
	Receiver input voltage		−25	25		
T <sub>A</sub>	Operating free-air temperature	SN65C3232E	−40	85	°C	
		SN75C3232E	0	70		

- Test conditions are C1–C4 = 0.1 μF at V<sub>CC</sub> = 3.3 V ± 0.3 V; C1 = 0.047 μF, C2–C4 = 0.33 μF at V<sub>CC</sub> = 5 V ± 0.5 V (see [Figure 4](#)).

### Electrical Characteristics<sup>(1)</sup>

over recommended ranges of supply voltage and operating free-air temperature (unless otherwise noted)

PARAMETER	TEST CONDITIONS	MIN	TYP <sup>(2)</sup>	MAX	UNIT
I <sub>CC</sub>	Supply current	No load, V <sub>CC</sub> = 3.3 V or 5 V	0.3	1	mA

- Test conditions are C1–C4 = 0.1 μF at V<sub>CC</sub> = 3.3 V ± 0.3 V; C1 = 0.047 μF, C2–C4 = 0.33 μF at V<sub>CC</sub> = 5 V ± 0.5 V (see [Figure 4](#)).
- All typical values are at V<sub>CC</sub> = 3.3 V or V<sub>CC</sub> = 5 V, and T<sub>A</sub> = 25°C.

## DRIVER SECTION

### Electrical Characteristics<sup>(1)</sup>

over recommended ranges of supply voltage and operating free-air temperature (unless otherwise noted)

PARAMETER	TEST CONDITIONS	MIN	TYP <sup>(2)</sup>	MAX	UNIT
V <sub>OH</sub> High-level output voltage	DOUT at R <sub>L</sub> = 3 kΩ to GND, DIN = GND	5	5.5		V
V <sub>OL</sub> Low-level output voltage	DOUT at R <sub>L</sub> = 3 kΩ to GND, DIN = V <sub>CC</sub>	–5	–5.4		V
I <sub>IH</sub> High-level input current	V <sub>I</sub> = V <sub>CC</sub>		±0.01	±1	μA
I <sub>IL</sub> Low-level input current	V <sub>I</sub> at GND		±0.01	±1	μA
I <sub>OS</sub> <sup>(3)</sup> Short-circuit output current	V <sub>CC</sub> = 3.6 V, V <sub>O</sub> = 0 V		±35	±60	mA
	V <sub>CC</sub> = 5.5 V, V <sub>O</sub> = 0 V		±35	±90	
r <sub>o</sub> Output resistance	V <sub>CC</sub> , V+, and V– = 0 V, V <sub>O</sub> = ±2 V	300	10M		Ω

(1) Test conditions are C1–C4 = 0.1 μF at V<sub>CC</sub> = 3.3 V ± 0.3 V; C1 = 0.047 μF, C2–C4 = 0.33 μF at V<sub>CC</sub> = 5 V ± 0.5 V (see Figure 4).

(2) All typical values are at V<sub>CC</sub> = 3.3 V or V<sub>CC</sub> = 5 V, and T<sub>A</sub> = 25°C.

(3) Short-circuit durations should be controlled to prevent exceeding the device absolute power dissipation ratings, and not more than one output should be shorted at a time.

### Switching Characteristics<sup>(1)</sup>

over recommended ranges of supply voltage and operating free-air temperature (unless otherwise noted)

PARAMETER	TEST CONDITIONS	MIN	TYP <sup>(2)</sup>	MAX	UNIT
Maximum data rate (see Figure 1)	R <sub>L</sub> = 3 kΩ, One DOUT switching, C <sub>L</sub> = 250 pF, V <sub>CC</sub> = 3 V to 4.5 V		1000		kbit/s
	C <sub>L</sub> = 1000 pF, V <sub>CC</sub> = 3.5 V to 5.5 V		1000		
t <sub>sk(p)</sub> Pulse skew <sup>(3)</sup>	C <sub>L</sub> = 150 pF to 2500 pF, R <sub>L</sub> = 3 kΩ to 7 kΩ, See Figure 2		300		ns
SR(tr) Slew rate, transition region (see Figure 1)	R <sub>L</sub> = 3 kΩ to 7 kΩ, C <sub>L</sub> = 150 pF to 1000 pF, V <sub>CC</sub> = 3.3 V		14	150	V/μs

(1) Test conditions are C1–C4 = 0.1 μF at V<sub>CC</sub> = 3.3 V ± 0.3 V; C1 = 0.047 μF, C2–C4 = 0.33 μF at V<sub>CC</sub> = 5 V ± 0.5 V (see Figure 4).

(2) All typical values are at V<sub>CC</sub> = 3.3 V or V<sub>CC</sub> = 5 V, and T<sub>A</sub> = 25°C.

(3) Pulse skew is defined as |t<sub>PLH</sub> – t<sub>PHL</sub>| of each channel of the same device.

## ESD Protection

TERMINAL		TEST CONDITIONS	TYP	UNIT
NAME	NO.			
DOUT	7, 14	HBM	±15	kV
		IEC 61000-4-2 Air-Gap Discharge	±15	
		IEC 61000-4-2 Contact Discharge	±8	

# SN65C3232E, SN75C3232E 3-V TO 5.5-V TWO-CHANNEL RS-232 1-MBIT/S LINE DRIVERS/RECEIVERS WITH $\pm 15$ -kV IEC ESD PROTECTION

SLLS697A–DECEMBER 2005–REVISED DECEMBER 2007

## RECEIVER SECTION

### Electrical Characteristics<sup>(1)</sup>

over recommended ranges of supply voltage and operating free-air temperature (unless otherwise noted)

PARAMETER	TEST CONDITIONS	MIN	TYP <sup>(2)</sup>	MAX	UNIT
$V_{OH}$ High-level output voltage	$I_{OH} = -1$ mA	$V_{CC} - 0.6$	$V_{CC} - 0.1$		V
$V_{OL}$ Low-level output voltage	$I_{OL} = 1.6$ mA			0.4	V
$V_{IT+}$ Positive-going input threshold voltage	$V_{CC} = 3.3$ V		1.5	2.4	V
	$V_{CC} = 5$ V		1.8	2.4	
$V_{IT-}$ Negative-going input threshold voltage	$V_{CC} = 3.3$ V	0.6	1.2		V
	$V_{CC} = 5$ V	0.8	1.5		
$V_{hys}$ Input hysteresis ( $V_{IT+} - V_{IT-}$ )			0.3		V
$r_i$ Input resistance	$V_I = \pm 3$ V to $\pm 25$ V	3	5	7	k $\Omega$

(1) Test conditions are  $C1-C4 = 0.1$   $\mu$ F at  $V_{CC} = 3.3$  V  $\pm 0.3$  V;  $C1 = 0.047$   $\mu$ F,  $C2-C4 = 0.33$   $\mu$ F at  $V_{CC} = 5$  V  $\pm 0.5$  V (see Figure 4).

(2) All typical values are at  $V_{CC} = 3.3$  V or  $V_{CC} = 5$  V, and  $T_A = 25^\circ$ C.

### Switching Characteristics<sup>(1)</sup>

over recommended ranges of supply voltage and operating free-air temperature (unless otherwise noted)

PARAMETER	TEST CONDITIONS	TYP <sup>(2)</sup>	UNIT
$t_{PLH}$ Propagation delay time, low- to high-level output	$C_L = 150$ pF	300	ns
$t_{PHL}$ Propagation delay time, high- to low-level output		300	ns
$t_{sk(p)}$ Pulse skew <sup>(3)</sup>		300	ns

(1) Test conditions are  $C1-C4 = 0.1$   $\mu$ F at  $V_{CC} = 3.3$  V  $\pm 0.3$  V;  $C1 = 0.047$   $\mu$ F,  $C2-C4 = 0.33$   $\mu$ F at  $V_{CC} = 5$  V  $\pm 0.5$  V (see Figure 4).

(2) All typical values are at  $V_{CC} = 3.3$  V or  $V_{CC} = 5$  V, and  $T_A = 25^\circ$ C.

(3) Pulse skew is defined as  $|t_{PLH} - t_{PHL}|$  of each channel of the same device.

## ESD Protection

TERMINAL		TEST CONDITIONS	TYP	UNIT
NAME	NO.			
RIN	8, 13	HBM	$\pm 15$	kV
		IEC 61000-4-2 Air-Gap Discharge	$\pm 15$	
		IEC 61000-4-2 Contact Discharge	$\pm 8$	

PARAMETER MEASUREMENT INFORMATION

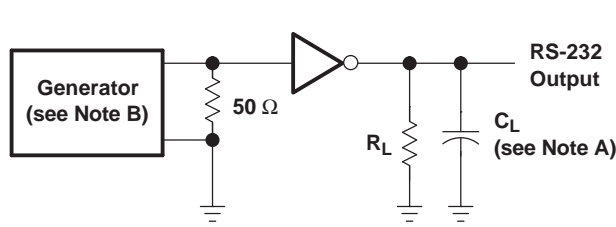

TEST CIRCUIT

$$SR(tr) = \frac{6\text{ V}}{t_{THL} \text{ or } t_{TLH}}$$

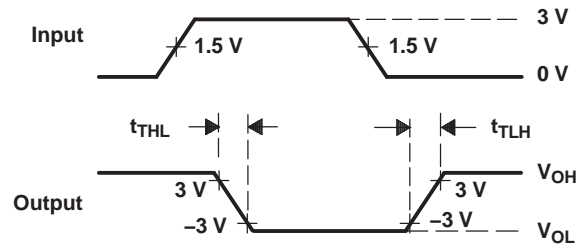

VOLTAGE WAVEFORMS

- NOTES: A. C<sub>L</sub> includes probe and jig capacitance.  
B. The pulse generator has the following characteristics: PRR = 250 kbit/s, Z<sub>O</sub> = 50 Ω, 50% duty cycle, t<sub>r</sub> ≤ 10 ns, t<sub>f</sub> ≤ 10 ns.

Figure 1. Driver Slew Rate

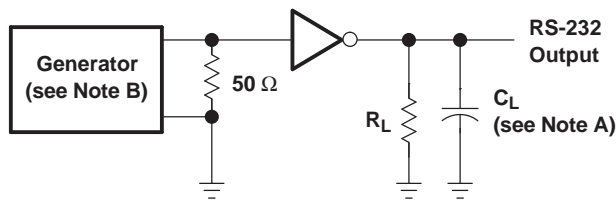

TEST CIRCUIT

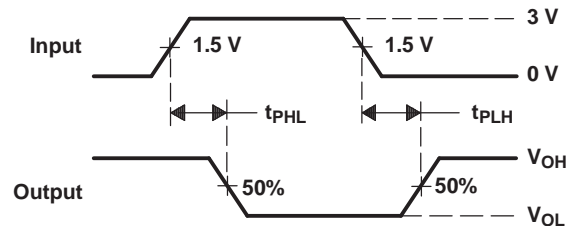

VOLTAGE WAVEFORMS

- NOTES: A. C<sub>L</sub> includes probe and jig capacitance.  
B. The pulse generator has the following characteristics: PRR = 250 kbit/s, Z<sub>O</sub> = 50 Ω, 50% duty cycle, t<sub>r</sub> ≤ 10 ns, t<sub>f</sub> ≤ 10 ns.

Figure 2. Driver Pulse Skew

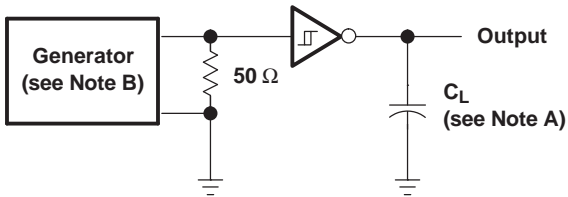

TEST CIRCUIT

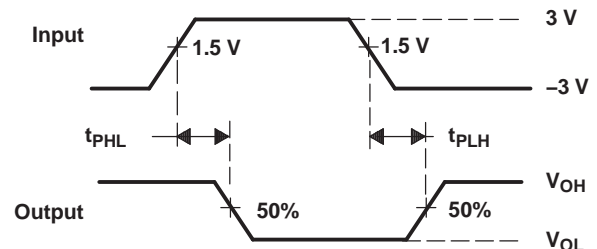

VOLTAGE WAVEFORMS

- NOTES: A. C<sub>L</sub> includes probe and jig capacitance.  
B. The pulse generator has the following characteristics: Z<sub>O</sub> = 50 Ω, 50% duty cycle, t<sub>r</sub> ≤ 10 ns, t<sub>f</sub> ≤ 10 ns.

Figure 3. Receiver Propagation Delay Times

**APPLICATION INFORMATION**

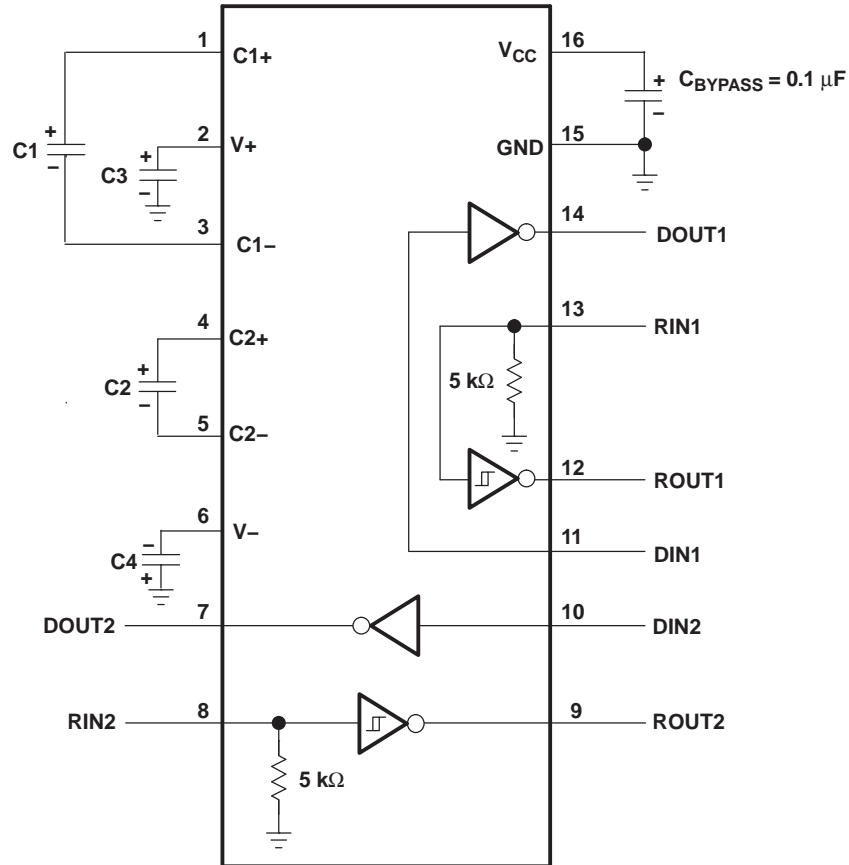

**V<sub>CC</sub> vs CAPACITOR VALUES**

V <sub>CC</sub>	C1	C2, C3, C4
3.3 V ± 0.3 V	0.1 μF	0.1 μF
5 V ± 0.5 V	0.047 μF	0.33 μF
3 V to 5.5 V	0.1 μF	0.47 μF

A. C3 can be connected to V<sub>CC</sub> or GND.

**Figure 4. Typical Operating Circuit and Capacitor Values**

**PACKAGING INFORMATION**

Orderable Device	Status <sup>(1)</sup>	Package Type	Package Drawing	Pins	Package Qty	Eco Plan <sup>(2)</sup>	Lead/Ball Finish	MSL Peak Temp <sup>(3)</sup>
SN65C3232ED	ACTIVE	SOIC	D	16	40	Green (RoHS & no Sb/Br)	CU NIPDAU	Level-1-260C-UNLIM
SN65C3232EDB	ACTIVE	SSOP	DB	16	80	Green (RoHS & no Sb/Br)	CU NIPDAU	Level-1-260C-UNLIM
SN65C3232EDBG4	ACTIVE	SSOP	DB	16	80	Green (RoHS & no Sb/Br)	CU NIPDAU	Level-1-260C-UNLIM
SN65C3232EDBR	ACTIVE	SSOP	DB	16	2000	Green (RoHS & no Sb/Br)	CU NIPDAU	Level-1-260C-UNLIM
SN65C3232EDBRG4	ACTIVE	SSOP	DB	16	2000	Green (RoHS & no Sb/Br)	CU NIPDAU	Level-1-260C-UNLIM
SN65C3232EDE4	ACTIVE	SOIC	D	16	40	Green (RoHS & no Sb/Br)	CU NIPDAU	Level-1-260C-UNLIM
SN65C3232EDG4	ACTIVE	SOIC	D	16	40	Green (RoHS & no Sb/Br)	CU NIPDAU	Level-1-260C-UNLIM
SN65C3232EDR	ACTIVE	SOIC	D	16	2500	Green (RoHS & no Sb/Br)	CU NIPDAU	Level-1-260C-UNLIM
SN65C3232EDRE4	ACTIVE	SOIC	D	16	2500	Green (RoHS & no Sb/Br)	CU NIPDAU	Level-1-260C-UNLIM
SN65C3232EDRG4	ACTIVE	SOIC	D	16	2500	Green (RoHS & no Sb/Br)	CU NIPDAU	Level-1-260C-UNLIM
SN65C3232EDW	ACTIVE	SOIC	DW	16	40	Green (RoHS & no Sb/Br)	CU NIPDAU	Level-1-260C-UNLIM
SN65C3232EDWG4	ACTIVE	SOIC	DW	16	40	Green (RoHS & no Sb/Br)	CU NIPDAU	Level-1-260C-UNLIM
SN65C3232EDWR	ACTIVE	SOIC	DW	16	2000	Green (RoHS & no Sb/Br)	CU NIPDAU	Level-1-260C-UNLIM
SN65C3232EDWRG4	ACTIVE	SOIC	DW	16	2000	Green (RoHS & no Sb/Br)	CU NIPDAU	Level-1-260C-UNLIM
SN65C3232EPW	ACTIVE	TSSOP	PW	16	90	Green (RoHS & no Sb/Br)	CU NIPDAU	Level-1-260C-UNLIM
SN65C3232EPWE4	ACTIVE	TSSOP	PW	16	90	Green (RoHS & no Sb/Br)	CU NIPDAU	Level-1-260C-UNLIM
SN65C3232EPWG4	ACTIVE	TSSOP	PW	16	90	Green (RoHS & no Sb/Br)	CU NIPDAU	Level-1-260C-UNLIM
SN65C3232EPWR	ACTIVE	TSSOP	PW	16	2000	Green (RoHS & no Sb/Br)	CU NIPDAU	Level-1-260C-UNLIM
SN65C3232EPWRE4	ACTIVE	TSSOP	PW	16	2000	Green (RoHS & no Sb/Br)	CU NIPDAU	Level-1-260C-UNLIM
SN65C3232EPWRG4	ACTIVE	TSSOP	PW	16	2000	Green (RoHS & no Sb/Br)	CU NIPDAU	Level-1-260C-UNLIM
SN75C3232ED	ACTIVE	SOIC	D	16	40	Green (RoHS & no Sb/Br)	CU NIPDAU	Level-1-260C-UNLIM
SN75C3232EDB	ACTIVE	SSOP	DB	16	80	Green (RoHS & no Sb/Br)	CU NIPDAU	Level-1-260C-UNLIM
SN75C3232EDBG4	ACTIVE	SSOP	DB	16	80	Green (RoHS & no Sb/Br)	CU NIPDAU	Level-1-260C-UNLIM
SN75C3232EDBR	ACTIVE	SSOP	DB	16	2000	Green (RoHS & no Sb/Br)	CU NIPDAU	Level-1-260C-UNLIM
SN75C3232EDBRG4	ACTIVE	SSOP	DB	16	2000	Green (RoHS & no Sb/Br)	CU NIPDAU	Level-1-260C-UNLIM

Orderable Device	Status <sup>(1)</sup>	Package Type	Package Drawing	Pins	Package Qty	Eco Plan <sup>(2)</sup>	Lead/Ball Finish	MSL Peak Temp <sup>(3)</sup>
SN75C3232EDE4	ACTIVE	SOIC	D	16	40	Green (RoHS & no Sb/Br)	CU NIPDAU	Level-1-260C-UNLIM
SN75C3232EDG4	ACTIVE	SOIC	D	16	40	Green (RoHS & no Sb/Br)	CU NIPDAU	Level-1-260C-UNLIM
SN75C3232EDR	ACTIVE	SOIC	D	16	2500	Green (RoHS & no Sb/Br)	CU NIPDAU	Level-1-260C-UNLIM
SN75C3232EDRE4	ACTIVE	SOIC	D	16	2500	Green (RoHS & no Sb/Br)	CU NIPDAU	Level-1-260C-UNLIM
SN75C3232EDRG4	ACTIVE	SOIC	D	16	2500	Green (RoHS & no Sb/Br)	CU NIPDAU	Level-1-260C-UNLIM
SN75C3232EDW	ACTIVE	SOIC	DW	16	40	Green (RoHS & no Sb/Br)	CU NIPDAU	Level-1-260C-UNLIM
SN75C3232EDWG4	ACTIVE	SOIC	DW	16	40	Green (RoHS & no Sb/Br)	CU NIPDAU	Level-1-260C-UNLIM
SN75C3232EDWR	ACTIVE	SOIC	DW	16	2000	Green (RoHS & no Sb/Br)	CU NIPDAU	Level-1-260C-UNLIM
SN75C3232EDWRG4	ACTIVE	SOIC	DW	16	2000	Green (RoHS & no Sb/Br)	CU NIPDAU	Level-1-260C-UNLIM
SN75C3232EPW	ACTIVE	TSSOP	PW	16	90	Green (RoHS & no Sb/Br)	CU NIPDAU	Level-1-260C-UNLIM
SN75C3232EPWE4	ACTIVE	TSSOP	PW	16	90	Green (RoHS & no Sb/Br)	CU NIPDAU	Level-1-260C-UNLIM
SN75C3232EPWG4	ACTIVE	TSSOP	PW	16	90	Green (RoHS & no Sb/Br)	CU NIPDAU	Level-1-260C-UNLIM
SN75C3232EPWR	ACTIVE	TSSOP	PW	16	2000	Green (RoHS & no Sb/Br)	CU NIPDAU	Level-1-260C-UNLIM
SN75C3232EPWRE4	ACTIVE	TSSOP	PW	16	2000	Green (RoHS & no Sb/Br)	CU NIPDAU	Level-1-260C-UNLIM
SN75C3232EPWRG4	ACTIVE	TSSOP	PW	16	2000	Green (RoHS & no Sb/Br)	CU NIPDAU	Level-1-260C-UNLIM

<sup>(1)</sup> The marketing status values are defined as follows:

**ACTIVE:** Product device recommended for new designs.

**LIFEBUY:** TI has announced that the device will be discontinued, and a lifetime-buy period is in effect.

**NRND:** Not recommended for new designs. Device is in production to support existing customers, but TI does not recommend using this part in a new design.

**PREVIEW:** Device has been announced but is not in production. Samples may or may not be available.

**OBSOLETE:** TI has discontinued the production of the device.

<sup>(2)</sup> Eco Plan - The planned eco-friendly classification: Pb-Free (RoHS), Pb-Free (RoHS Exempt), or Green (RoHS & no Sb/Br) - please check <http://www.ti.com/productcontent> for the latest availability information and additional product content details.

**TBD:** The Pb-Free/Green conversion plan has not been defined.

**Pb-Free (RoHS):** TI's terms "Lead-Free" or "Pb-Free" mean semiconductor products that are compatible with the current RoHS requirements for all 6 substances, including the requirement that lead not exceed 0.1% by weight in homogeneous materials. Where designed to be soldered at high temperatures, TI Pb-Free products are suitable for use in specified lead-free processes.

**Pb-Free (RoHS Exempt):** This component has a RoHS exemption for either 1) lead-based flip-chip solder bumps used between the die and package, or 2) lead-based die adhesive used between the die and leadframe. The component is otherwise considered Pb-Free (RoHS compatible) as defined above.

**Green (RoHS & no Sb/Br):** TI defines "Green" to mean Pb-Free (RoHS compatible), and free of Bromine (Br) and Antimony (Sb) based flame retardants (Br or Sb do not exceed 0.1% by weight in homogeneous material)

<sup>(3)</sup> MSL, Peak Temp. -- The Moisture Sensitivity Level rating according to the JEDEC industry standard classifications, and peak solder temperature.

**Important Information and Disclaimer:**The information provided on this page represents TI's knowledge and belief as of the date that it is

provided. TI bases its knowledge and belief on information provided by third parties, and makes no representation or warranty as to the accuracy of such information. Efforts are underway to better integrate information from third parties. TI has taken and continues to take reasonable steps to provide representative and accurate information but may not have conducted destructive testing or chemical analysis on incoming materials and chemicals. TI and TI suppliers consider certain information to be proprietary, and thus CAS numbers and other limited information may not be available for release.

In no event shall TI's liability arising out of such information exceed the total purchase price of the TI part(s) at issue in this document sold by TI to Customer on an annual basis.

**TAPE AND REEL INFORMATION**
**REEL DIMENSIONS**

**TAPE DIMENSIONS**

A0	Dimension designed to accommodate the component width
B0	Dimension designed to accommodate the component length
K0	Dimension designed to accommodate the component thickness
W	Overall width of the carrier tape
P1	Pitch between successive cavity centers

**TAPE AND REEL INFORMATION**

\*All dimensions are nominal

Device	Package Type	Package Drawing	Pins	SPQ	Reel Diameter (mm)	Reel Width W1 (mm)	A0 (mm)	B0 (mm)	K0 (mm)	P1 (mm)	W (mm)	Pin1 Quadrant
SN65C3232EDBR	SSOP	DB	16	2000	330.0	16.4	8.2	6.6	2.5	12.0	16.0	Q1
SN65C3232EDR	SOIC	D	16	2500	330.0	16.4	6.5	10.3	2.1	8.0	16.0	Q1
SN65C3232EDWR	SOIC	DW	16	2000	330.0	16.4	10.75	10.7	2.7	12.0	16.0	Q1
SN65C3232EPWR	TSSOP	PW	16	2000	330.0	12.4	6.9	5.6	1.6	8.0	12.0	Q1
SN75C3232EDBR	SSOP	DB	16	2000	330.0	16.4	8.2	6.6	2.5	12.0	16.0	Q1
SN75C3232EDR	SOIC	D	16	2500	330.0	16.4	6.5	10.3	2.1	8.0	16.0	Q1
SN75C3232EDWR	SOIC	DW	16	2000	330.0	16.4	10.75	10.7	2.7	12.0	16.0	Q1
SN75C3232EPWR	TSSOP	PW	16	2000	330.0	12.4	6.9	5.6	1.6	8.0	12.0	Q1

**TAPE AND REEL BOX DIMENSIONS**

\*All dimensions are nominal

Device	Package Type	Package Drawing	Pins	SPQ	Length (mm)	Width (mm)	Height (mm)
SN65C3232EDBR	SSOP	DB	16	2000	367.0	367.0	38.0
SN65C3232EDR	SOIC	D	16	2500	367.0	367.0	38.0
SN65C3232EDWR	SOIC	DW	16	2000	367.0	367.0	38.0
SN65C3232EPWR	TSSOP	PW	16	2000	367.0	367.0	35.0
SN75C3232EDBR	SSOP	DB	16	2000	367.0	367.0	38.0
SN75C3232EDR	SOIC	D	16	2500	367.0	367.0	38.0
SN75C3232EDWR	SOIC	DW	16	2000	367.0	367.0	38.0
SN75C3232EPWR	TSSOP	PW	16	2000	367.0	367.0	35.0

D (R-PDSO-G16)

PLASTIC SMALL OUTLINE

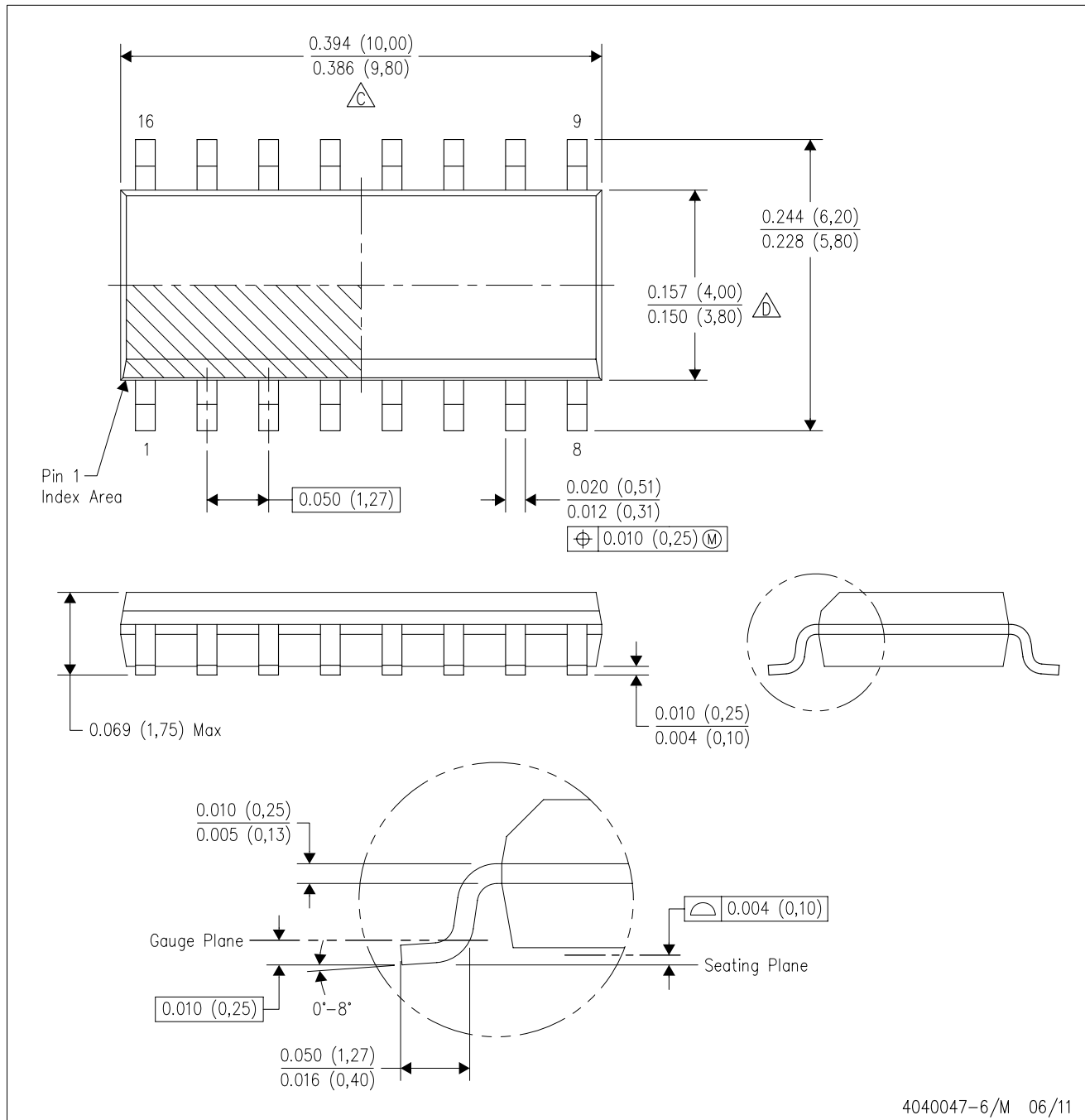

- NOTES:
- A. All linear dimensions are in inches (millimeters).
  - B. This drawing is subject to change without notice.
  - C. Body length does not include mold flash, protrusions, or gate burrs. Mold flash, protrusions, or gate burrs shall not exceed 0.006 (0,15) each side.
  - D. Body width does not include interlead flash. Interlead flash shall not exceed 0.017 (0,43) each side.
  - E. Reference JEDEC MS-012 variation AC.

D (R-PDSO-G16)

PLASTIC SMALL OUTLINE



- NOTES:
- All linear dimensions are in millimeters.
  - This drawing is subject to change without notice.
  - Publication IPC-7351 is recommended for alternate designs.
  - Laser cutting apertures with trapezoidal walls and also rounding corners will offer better paste release. Customers should contact their board assembly site for stencil design recommendations. Refer to IPC-7525 for other stencil recommendations.
  - Customers should contact their board fabrication site for solder mask tolerances between and around signal pads.

PW (R-PDSO-G16)

PLASTIC SMALL OUTLINE

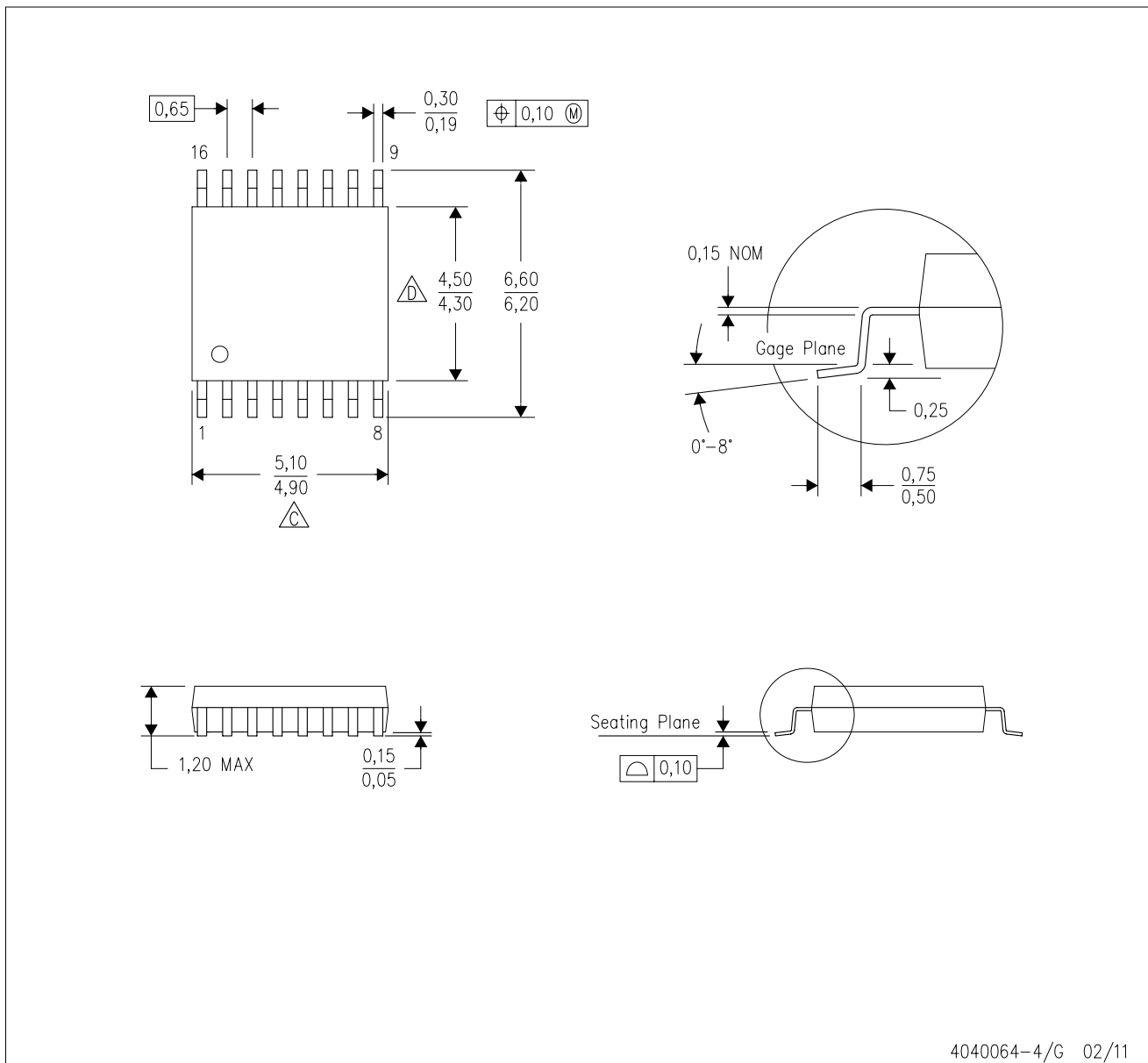

4040064-4/G 02/11

- NOTES:
- A. All linear dimensions are in millimeters. Dimensioning and tolerancing per ASME Y14.5M-1994.
  - B. This drawing is subject to change without notice.
  - C. Body length does not include mold flash, protrusions, or gate burrs. Mold flash, protrusions, or gate burrs shall not exceed 0,15 each side.
  - D. Body width does not include interlead flash. Interlead flash shall not exceed 0,25 each side.
  - E. Falls within JEDEC MO-153

PW (R-PDSO-G16)

PLASTIC SMALL OUTLINE

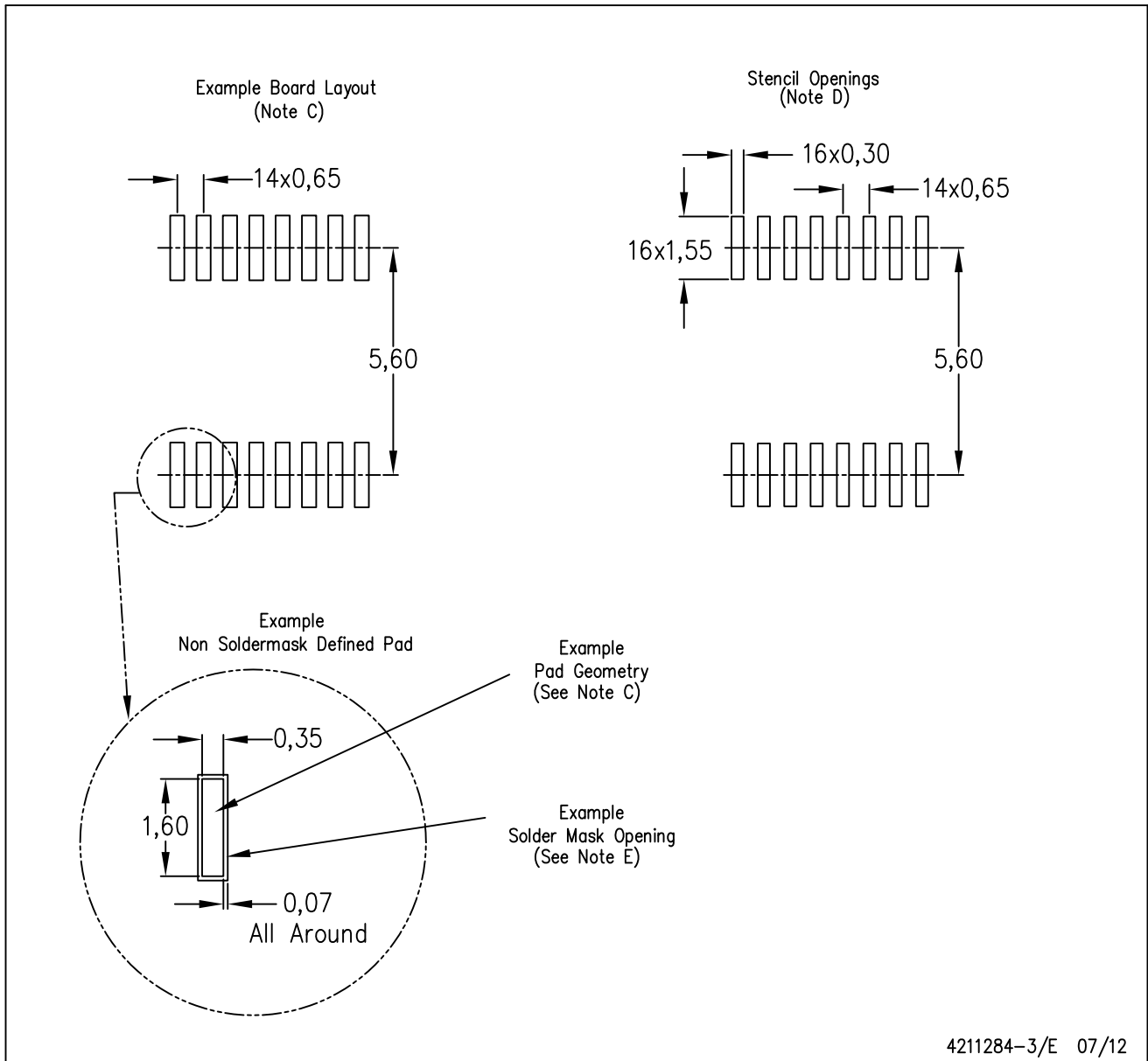

- NOTES:
- All linear dimensions are in millimeters.
  - This drawing is subject to change without notice.
  - Publication IPC-7351 is recommended for alternate designs.
  - Laser cutting apertures with trapezoidal walls and also rounding corners will offer better paste release. Customers should contact their board assembly site for stencil design recommendations. Refer to IPC-7525 for other stencil recommendations.
  - Customers should contact their board fabrication site for solder mask tolerances between and around signal pads.

DW (R-PDSO-G16)

PLASTIC SMALL OUTLINE



- NOTES:
- A. All linear dimensions are in inches (millimeters). Dimensioning and tolerancing per ASME Y14.5M-1994.
  - B. This drawing is subject to change without notice.
  - C. Body dimensions do not include mold flash or protrusion not to exceed 0.006 (0,15).
  - D. Falls within JEDEC MS-013 variation AA.

DB (R-PDSO-G\*\*)

PLASTIC SMALL-OUTLINE

28 PINS SHOWN



- NOTES: A. All linear dimensions are in millimeters.  
 B. This drawing is subject to change without notice.  
 C. Body dimensions do not include mold flash or protrusion not to exceed 0,15.  
 D. Falls within JEDEC MO-150

## IMPORTANT NOTICE

Texas Instruments Incorporated and its subsidiaries (TI) reserve the right to make corrections, enhancements, improvements and other changes to its semiconductor products and services per JESD46, latest issue, and to discontinue any product or service per JESD48, latest issue. Buyers should obtain the latest relevant information before placing orders and should verify that such information is current and complete. All semiconductor products (also referred to herein as "components") are sold subject to TI's terms and conditions of sale supplied at the time of order acknowledgment.

TI warrants performance of its components to the specifications applicable at the time of sale, in accordance with the warranty in TI's terms and conditions of sale of semiconductor products. Testing and other quality control techniques are used to the extent TI deems necessary to support this warranty. Except where mandated by applicable law, testing of all parameters of each component is not necessarily performed.

TI assumes no liability for applications assistance or the design of Buyers' products. Buyers are responsible for their products and applications using TI components. To minimize the risks associated with Buyers' products and applications, Buyers should provide adequate design and operating safeguards.

TI does not warrant or represent that any license, either express or implied, is granted under any patent right, copyright, mask work right, or other intellectual property right relating to any combination, machine, or process in which TI components or services are used. Information published by TI regarding third-party products or services does not constitute a license to use such products or services or a warranty or endorsement thereof. Use of such information may require a license from a third party under the patents or other intellectual property of the third party, or a license from TI under the patents or other intellectual property of TI.

Reproduction of significant portions of TI information in TI data books or data sheets is permissible only if reproduction is without alteration and is accompanied by all associated warranties, conditions, limitations, and notices. TI is not responsible or liable for such altered documentation. Information of third parties may be subject to additional restrictions.

Resale of TI components or services with statements different from or beyond the parameters stated by TI for that component or service voids all express and any implied warranties for the associated TI component or service and is an unfair and deceptive business practice. TI is not responsible or liable for any such statements.

Buyer acknowledges and agrees that it is solely responsible for compliance with all legal, regulatory and safety-related requirements concerning its products, and any use of TI components in its applications, notwithstanding any applications-related information or support that may be provided by TI. Buyer represents and agrees that it has all the necessary expertise to create and implement safeguards which anticipate dangerous consequences of failures, monitor failures and their consequences, lessen the likelihood of failures that might cause harm and take appropriate remedial actions. Buyer will fully indemnify TI and its representatives against any damages arising out of the use of any TI components in safety-critical applications.

In some cases, TI components may be promoted specifically to facilitate safety-related applications. With such components, TI's goal is to help enable customers to design and create their own end-product solutions that meet applicable functional safety standards and requirements. Nonetheless, such components are subject to these terms.

No TI components are authorized for use in FDA Class III (or similar life-critical medical equipment) unless authorized officers of the parties have executed a special agreement specifically governing such use.

Only those TI components which TI has specifically designated as military grade or "enhanced plastic" are designed and intended for use in military/aerospace applications or environments. Buyer acknowledges and agrees that any military or aerospace use of TI components which have *not* been so designated is solely at the Buyer's risk, and that Buyer is solely responsible for compliance with all legal and regulatory requirements in connection with such use.

TI has specifically designated certain components as meeting ISO/TS16949 requirements, mainly for automotive use. In any case of use of non-designated products, TI will not be responsible for any failure to meet ISO/TS16949.

### Products

Audio	<a href="http://www.ti.com/audio">www.ti.com/audio</a>
Amplifiers	<a href="http://amplifier.ti.com">amplifier.ti.com</a>
Data Converters	<a href="http://dataconverter.ti.com">dataconverter.ti.com</a>
DLP® Products	<a href="http://www.dlp.com">www.dlp.com</a>
DSP	<a href="http://dsp.ti.com">dsp.ti.com</a>
Clocks and Timers	<a href="http://www.ti.com/clocks">www.ti.com/clocks</a>
Interface	<a href="http://interface.ti.com">interface.ti.com</a>
Logic	<a href="http://logic.ti.com">logic.ti.com</a>
Power Mgmt	<a href="http://power.ti.com">power.ti.com</a>
Microcontrollers	<a href="http://microcontroller.ti.com">microcontroller.ti.com</a>
RFID	<a href="http://www.ti-rfid.com">www.ti-rfid.com</a>
OMAP Applications Processors	<a href="http://www.ti.com/omap">www.ti.com/omap</a>
Wireless Connectivity	<a href="http://www.ti.com/wirelessconnectivity">www.ti.com/wirelessconnectivity</a>

### Applications

Automotive and Transportation	<a href="http://www.ti.com/automotive">www.ti.com/automotive</a>
Communications and Telecom	<a href="http://www.ti.com/communications">www.ti.com/communications</a>
Computers and Peripherals	<a href="http://www.ti.com/computers">www.ti.com/computers</a>
Consumer Electronics	<a href="http://www.ti.com/consumer-apps">www.ti.com/consumer-apps</a>
Energy and Lighting	<a href="http://www.ti.com/energy">www.ti.com/energy</a>
Industrial	<a href="http://www.ti.com/industrial">www.ti.com/industrial</a>
Medical	<a href="http://www.ti.com/medical">www.ti.com/medical</a>
Security	<a href="http://www.ti.com/security">www.ti.com/security</a>
Space, Avionics and Defense	<a href="http://www.ti.com/space-avionics-defense">www.ti.com/space-avionics-defense</a>
Video and Imaging	<a href="http://www.ti.com/video">www.ti.com/video</a>

### TI E2E Community

[e2e.ti.com](http://e2e.ti.com)