

- Optimized for Off-Line and dc-to-dc Converters
- Low Start-Up Current (<1 mA)
- Automatic Feed-Forward Compensation
- Pulse-by-Pulse Current Limiting
- Enhanced Load-Response Characteristics
- Undervoltage Lockout With Hysteresis
- Double-Pulse Suppression
- High-Current Totem-Pole Output
- Internally Trimmed Bandgap Reference
- 500-kHz Operation
- Error Amplifier With Low Output Resistance
- Designed to Be Interchangeable With UC2842 and UC3842 Series

description/ordering information

The TL284x and TL384x series of control integrated circuits provide the features that are necessary to implement off-line or dc-to-dc fixed-frequency current-mode control schemes, with a minimum number of external components. Some of the internally implemented circuits are an undervoltage lockout (UVLO), featuring a start-up current of less than 1 mA, and a precision reference trimmed for accuracy at the error amplifier input. Other internal circuits include logic to ensure latched operation, a pulse-width modulation (PWM) comparator (that also provides current-limit control), and a totem-pole output stage designed to source or sink high-peak current. The output stage, suitable for driving N-channel MOSFETs, is low when it is in the off state.

Major differences between members of these series are the UVLO thresholds and maximum duty-cycle ranges. Typical UVLO thresholds of 16 V (on) and 10 V (off) on the TLx842 and TLx844 devices make them ideally suited to off-line applications. The corresponding typical thresholds for the TLx843 and TLx845 devices are 8.4 V (on) and 7.6 V (off). The TLx842 and TLx843 devices can operate to duty cycles approaching 100%. A duty-cycle range of 0 to 50% is obtained by the TLx844 and TLx845 by the addition of an internal toggle flip-flop, which blanks the output off every other clock cycle.

The TL284x-series devices are characterized for operation from -40°C to 85°C . The TL384x-series devices are characterized for operation from 0°C to 70°C .

**D PACKAGE
(TOP VIEW)**

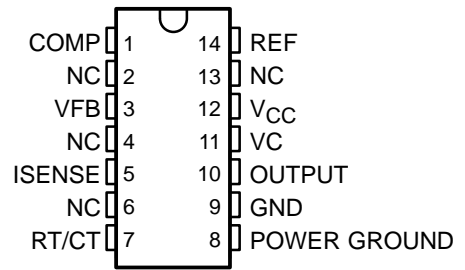

NC – No internal connection

**D-8 OR P PACKAGE
(TOP VIEW)**

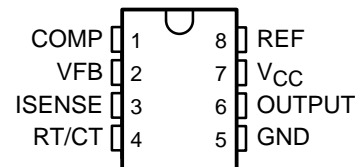

Please be aware that an important notice concerning availability, standard warranty, and use in critical applications of Texas Instruments semiconductor products and disclaimers thereto appears at the end of this data sheet.

PRODUCTION DATA information is current as of publication date. Products conform to specifications per the terms of Texas Instruments standard warranty. Production processing does not necessarily include testing of all parameters.

 **TEXAS
INSTRUMENTS**

POST OFFICE BOX 655303 • DALLAS, TEXAS 75265

Copyright © 2003, Texas Instruments Incorporated

TL284x, TL384x CURRENT-MODE PWM CONTROLLERS

SLVS038F – JANUARY 1989 – REVISED FEBRUARY 2003

ORDERING INFORMATION

T _A	PACKAGE†		ORDERABLE PART NUMBER	TOP-SIDE MARKING
0°C to 70°C	PDIP (P) (8 pin)	Tube of 50	TL3842P	TL3842P
			TL3843P	TL3843P
			TL3844P	TL3844P
			TL3845P	TL3845P
	SOIC (D) (8 pin)	Tube of 75	TL3842D-8	TL3842
		Reel of 2500	TL3842DR-8	
		Tube of 75	TL3843D-8	TL3843
		Reel of 2500	TL3843DR-8	
		Tube of 75	TL3844D-8	TL3844
		Reel of 2500	TL3844DR-8	
		Tube of 75	TL3845D-8	TL3845
		Reel of 2500	TL3845DR-8	
	SOIC (D) (14 pin)	Tube of 50	TL3842D	TL3842
		Reel of 2500	TL3842DR	
		Tube of 50	TL3843D	TL3843
		Reel of 2500	TL3843DR	
		Tube of 50	TL3844D	TL3844
		Reel of 2500	TL3844DR	
		Tube of 50	TL3845D	TL3845
		Reel of 2500	TL3845DR	
	-40°C to 85°C	PDIP (P) (8 pin)	Tube of 50	TL2842P
TL2843P				TL2843P
TL2844P				TL2844P
TL2845P				TL2845P
SOIC (D) (8 pin)		Tube of 75	TL2842D-8	TL2842
		Reel of 2500	TL2842DR-8	
		Tube of 75	TL2843D-8	TL2843
		Reel of 2500	TL2843DR-8	
		Tube of 75	TL2844D-8	TL2844
		Reel of 2500	TL2844DR-8	
		Tube of 75	TL2845D-8	TL2845
		Reel of 2500	TL2845DR-8	
SOIC (D) (14 pin)		Tube of 50	TL2842D	TL2842
		Reel of 2500	TL2842DR	
		Tube of 50	TL2843D	TL2843
		Reel of 2500	TL2843DR	
		Tube of 50	TL2844D	TL2844
		Reel of 2500	TL2844DR	
		Tube of 50	TL2845D	TL2845
		Reel of 2500	TL2845DR	

† Package drawings, standard packing quantities, thermal data, symbolization, and PCB design guidelines are available at www.ti.com/sc/package.



POST OFFICE BOX 655303 • DALLAS, TEXAS 75265

TL284x, TL384x CURRENT-MODE PWM CONTROLLERS

SLVS038F – JANUARY 1989 – REVISED FEBRUARY 2003

absolute maximum ratings over operating free-air temperature range (unless otherwise noted)†

Supply voltage (see Note 1) ($I_{CC} < 30 \text{ mA}$)	Self limiting
Analog input voltage range, V_I (VFB and ISENSE)	-0.3 V to 6.3 V
Output voltage, V_O (OUTPUT)	35 V
Input voltage, V_I , (VC, D package only)	35 V
Supply current, I_{CC}	30 mA
Output current, I_O	$\pm 1 \text{ A}$
Error amplifier output sink current	10 mA
Package thermal impedance, θ_{JA} (see Notes 2 and 3): D package	86°C/W
D-8 package	97°C/W
P package	85°C/W
Virtual junction temperature, T_J	150°C
Output energy (capacitive load)	5 μJ
Lead temperature, 1,6 mm (1/16 inch) from case for 10 seconds	260°C
Storage temperature range, T_{stg}	-65°C to 150°C

† Stresses beyond those listed under “absolute maximum ratings” may cause permanent damage to the device. These are stress ratings only, and functional operation of the device at these or any other conditions beyond those indicated under “recommended operating conditions” is not implied. Exposure to absolute-maximum-rated conditions for extended periods may affect device reliability.

- NOTES:
1. All voltages are with respect to the device GND terminal.
 2. Maximum power dissipation is a function of $T_J(\text{max})$, θ_{JA} , and T_A . The maximum allowable power dissipation at any allowable ambient temperature is $P_D = (T_J(\text{max}) - T_A)/\theta_{JA}$. Operating at the absolute maximum T_J of 150°C can impact reliability.
 3. The package thermal impedance is calculated in accordance with JESD 51-7.

recommended operating conditions

		MIN	NOM	MAX	UNIT
V_{CC} and $V_{C\ddagger}$	Supply voltage			30	V
V_I , RT/CT	Input voltage	0		5.5	V
V_I , VFB and ISENSE	Input voltage	0		5.5	V
V_O , OUTPUT	Output voltage	0		30	V
V_O , POWER GROUND \ddagger	Output voltage	-0.1		1	V
I_{CC}	Supply current, externally limited			25	mA
I_O	Average output current			200	mA
$I_{O(\text{ref})}$	Reference output current			-20	mA
f_{osc}	Oscillator frequency		100	500	kHz
T_A	Operating free-air temperature	TL284x	-40	85	°C
		TL384x	0	70	

\ddagger These recommended voltages for VC and POWER GROUND apply only to the D package.



TL284x, TL384x CURRENT-MODE PWM CONTROLLERS

SLVS038F – JANUARY 1989 – REVISED FEBRUARY 2003

electrical characteristics over recommended operating free-air temperature range, $V_{CC} = 15\text{ V}$ (see Note 4), $R_T = 10\text{ k}\Omega$, $C_T = 3.3\text{ nF}$ (unless otherwise specified)

reference section

PARAMETER	TEST CONDITIONS	TL284x			TL384x			UNIT
		MIN	TYP†	MAX	MIN	TYP†	MAX	
Output voltage	$I_O = 1\text{ mA}$, $T_A = 25^\circ\text{C}$	4.95	5	5.05	4.9	5	5.1	V
Line regulation	$V_{CC} = 12\text{ V to }25\text{ V}$		6	20		6	20	mV
Load regulation	$I_O = 1\text{ mA to }20\text{ mA}$		6	25		6	25	mV
Temperature coefficient of output voltage			0.2	0.4		0.2	0.4	mV/°C
Output voltage with worst-case variation	$V_{CC} = 12\text{ V to }25\text{ V}$, $I_O = 1\text{ mA to }20\text{ mA}$	4.9		5.1	4.82		5.18	V
Output noise voltage	$f = 10\text{ Hz to }10\text{ kHz}$, $T_A = 25^\circ\text{C}$		50			50		μV
Output-voltage long-term drift	After 1000 h at $T_A = 25^\circ\text{C}$		5	25		5	25	mV
Short-circuit output current		-30	-100	-180	-30	-100	-180	mA

† All typical values are at $T_A = 25^\circ\text{C}$.

NOTE 4: Adjust V_{CC} above the start threshold before setting it to 15 V.

oscillator section

PARAMETER	TEST CONDITIONS	TL284x			TL384x			UNIT
		MIN	TYP†	MAX	MIN	TYP†	MAX	
Oscillator frequency (see Note 5)	$T_A = 25^\circ\text{C}$	47	52	57	47	52	57	kHz
Frequency change with supply voltage	$V_{CC} = 12\text{ V to }25\text{ V}$		2	10		2	10	Hz/kHz
Frequency change with temperature			50			50		Hz/kHz
Peak-to-peak amplitude at RT/CT			1.7			1.7		V

† All typical values are at $T_A = 25^\circ\text{C}$.

NOTES: 4. Adjust V_{CC} above the start threshold before setting it to 15 V.

5. Output frequency equals oscillator frequency for the TLx842 and TLx843. Output frequency is one-half the oscillator frequency for the TLx844 and TLx845.

error-amplifier section

PARAMETER	TEST CONDITIONS	TL284x			TL384x			UNIT
		MIN	TYP†	MAX	MIN	TYP†	MAX	
Feedback input voltage	COMP at 2.5 V	2.45	2.50	2.55	2.42	2.50	2.58	V
Input bias current			-0.3	-1		-0.3	-2	μA
Open-loop voltage amplification	$V_O = 2\text{ V to }4\text{ V}$	65	90		65	90		dB
Gain-bandwidth product		0.7	1		0.7	1		MHz
Supply-voltage rejection ratio	$V_{CC} = 12\text{ V to }25\text{ V}$	60	70		60	70		dB
Output sink current	VFB at 2.7 V, COMP at 1.1 V	2	6		2	6		mA
Output source current	VFB at 2.3 V, COMP at 5 V	-0.5	-0.8		-0.5	-0.8		mA
High-level output voltage	VFB at 2.3 V, $R_L = 15\text{ k}\Omega$ to GND	5	6		5	6		V
Low-level output voltage	VFB at 2.7 V, $R_L = 15\text{ k}\Omega$ to GND		0.7	1.1		0.7	1.1	V

† All typical values are at $T_A = 25^\circ\text{C}$.

NOTE 4: Adjust V_{CC} above the start threshold before setting it to 15 V.



TL284x, TL384x CURRENT-MODE PWM CONTROLLERS

SLVS038F – JANUARY 1989 – REVISED FEBRUARY 2003

electrical characteristics over recommended operating free-air temperature range, $V_{CC} = 15\text{ V}$ (see Note 4), $R_T = 10\text{ k}\Omega$, $C_T = 3.3\text{ nF}$ (unless otherwise specified) (continued)

current-sense section

PARAMETER	TEST CONDITIONS	TL284x			TL384x			UNIT
		MIN	TYP†	MAX	MIN	TYP†	MAX	
Voltage amplification	See Notes 6 and 7	2.85	3	3.13	2.85	3	3.15	V/V
Current-sense comparator threshold	COMP at 5 V, See Note 6	0.9	1	1.1	0.9	1	1.1	V
Supply-voltage rejection ratio	$V_{CC} = 12\text{ V}$ to 25 V , See Note 6	70			70			dB
Input bias current		-2 -10			-2 -10			μA
Delay time to output		150 300			150 300			ns

† All typical values are at $T_A = 25^\circ\text{C}$.

NOTES: 4. Adjust V_{CC} above the start threshold before setting it to 15 V.

6. These parameters are measured at the trip point of the latch, with VFB at 0 V.

7. Voltage amplification is measured between ISENSE and COMP, with the input changing from 0 V to 0.8 V.

output section

PARAMETER	TEST CONDITIONS	TL284x			TL384x			UNIT
		MIN	TYP†	MAX	MIN	TYP†	MAX	
High-level output voltage	$I_{OH} = -20\text{ mA}$	13	13.5		13	13.5		V
	$I_{OH} = -200\text{ mA}$	12	13.5		12	13.5		
Low-level output voltage	$I_{OL} = 20\text{ mA}$		0.1	0.4		0.1	0.4	V
	$I_{OL} = 200\text{ mA}$		1.5	2.2		1.5	2.2	
Rise time	$C_L = 1\text{ nF}$, $T_A = 25^\circ\text{C}$		50	150		50	150	ns
Fall time	$C_L = 1\text{ nF}$, $T_A = 25^\circ\text{C}$		50	150		50	150	ns

† All typical values are at $T_A = 25^\circ\text{C}$.

NOTE 4: Adjust V_{CC} above the start threshold before setting it to 15 V.

undervoltage-lockout section

PARAMETER		TL284x			TL384x			UNIT
		MIN	TYP†	MAX	MIN	TYP†	MAX	
Start threshold voltage	TLx842, TLx844	15	16	17	14.5	16	17.5	V
	TLx843, TLx845	7.8	8.4	9	7.8	8.4	9	
Minimum operating voltage after startup	TLx842, TLx844	9	10	11	8.5	10	11.5	V
	TLx843, TLx845	7	7.6	8.2	7	7.6	8.2	

† All typical values are at $T_A = 25^\circ\text{C}$.

NOTE 4: Adjust V_{CC} above the start threshold before setting it to 15 V.

pulse-width-modulator section

PARAMETER		TL284x			TL384x			UNIT
		MIN	TYP†	MAX	MIN	TYP†	MAX	
Maximum duty cycle	TLx842, TLx843	95	97	100	95	97	100	%
	TLx844, TLx845	46	48	50	46	48	50	
Minimum duty cycle		0			0			

† All typical values are at $T_A = 25^\circ\text{C}$.

NOTE 4: Adjust V_{CC} above the start threshold before setting it to 15 V.



TL284x, TL384x CURRENT-MODE PWM CONTROLLERS

SLVS038F – JANUARY 1989 – REVISED FEBRUARY 2003

electrical characteristics over recommended operating free-air temperature range, $V_{CC} = 15\text{ V}$ (see Note 4), $R_T = 10\text{ k}\Omega$, $C_T = 3.3\text{ nF}$ (unless otherwise specified) (continued)

supply voltage

PARAMETER	TEST CONDITIONS	TL284x			TL384x			UNIT
		MIN	TYP†	MAX	MIN	TYP†	MAX	
Start-up current			0.5	1		0.5	1	mA
Operating supply current	VFB and ISENSE at 0 V		11	17		11	17	mA
Limiting voltage	$I_{CC} = 25\text{ mA}$		34			34		V

† All typical values are at $T_A = 25^\circ\text{C}$.

NOTE 4: Adjust V_{CC} above the start threshold before setting it to 15 V.

APPLICATION INFORMATION

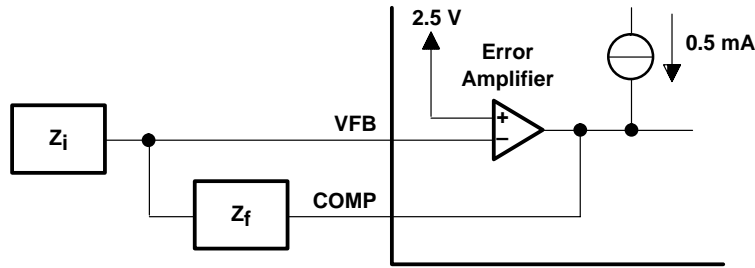

NOTE A: Error amplifier can source or sink up to 0.5 mA.

Figure 1. Error-Amplifier Configuration

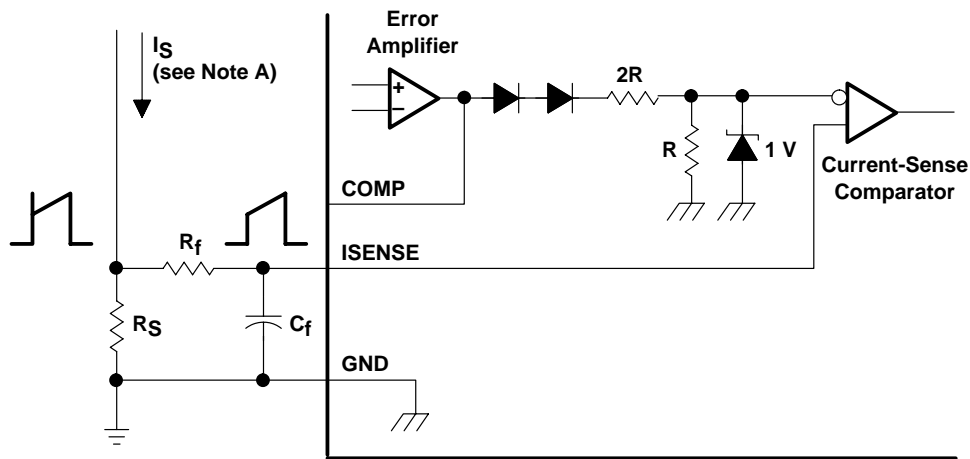

NOTE A: Peak current (I_S) is determined by the formula:

$$I_{S(max)} = \frac{1V}{R_S}$$

A small RC filter formed by resistor R_f and capacitor C_f may be required to suppress switch transients.

Figure 2. Current-Sense Circuit

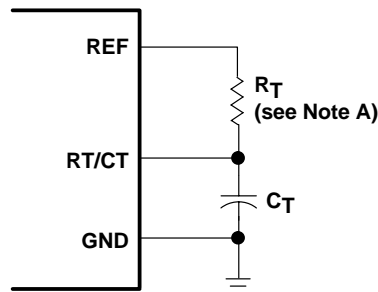

NOTE A: For $R_T > 5\text{ k}\Omega$: $f \approx \frac{1.72}{R_T C_T}$

Figure 3. Oscillator Section

APPLICATION INFORMATION

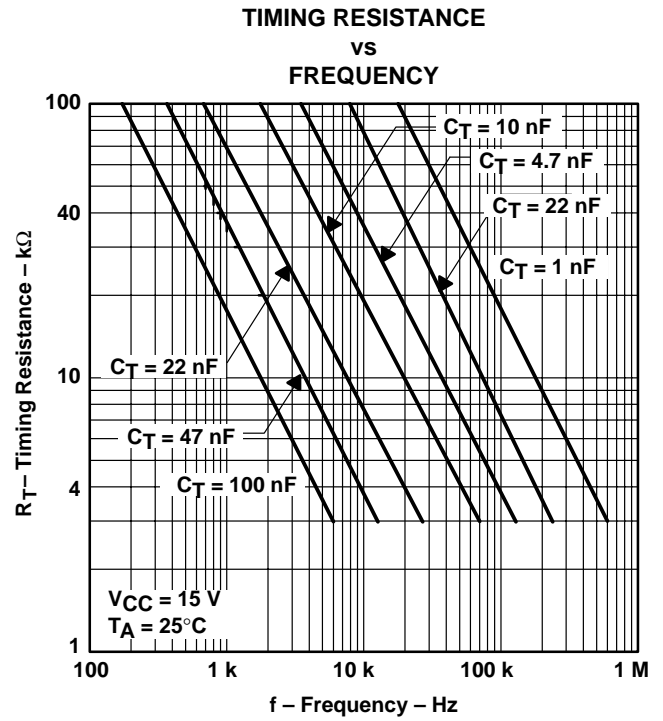
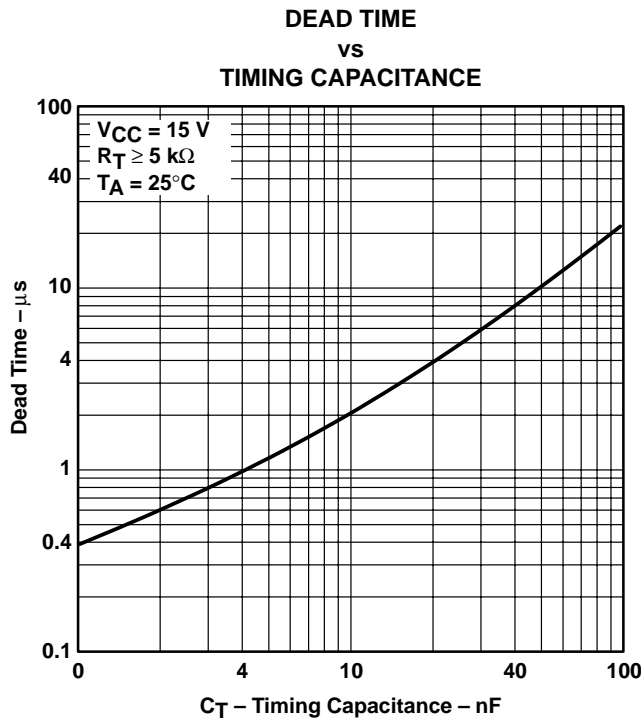

open-loop laboratory test fixture

In the open-loop laboratory test fixture (see Figure 6), high peak currents associated with loads necessitate careful grounding techniques. Timing and bypass capacitors should be connected close to the GND terminal in a single-point ground. The transistor and 5-kΩ potentiometer sample the oscillator waveform and apply an adjustable ramp to the ISENSE terminal.

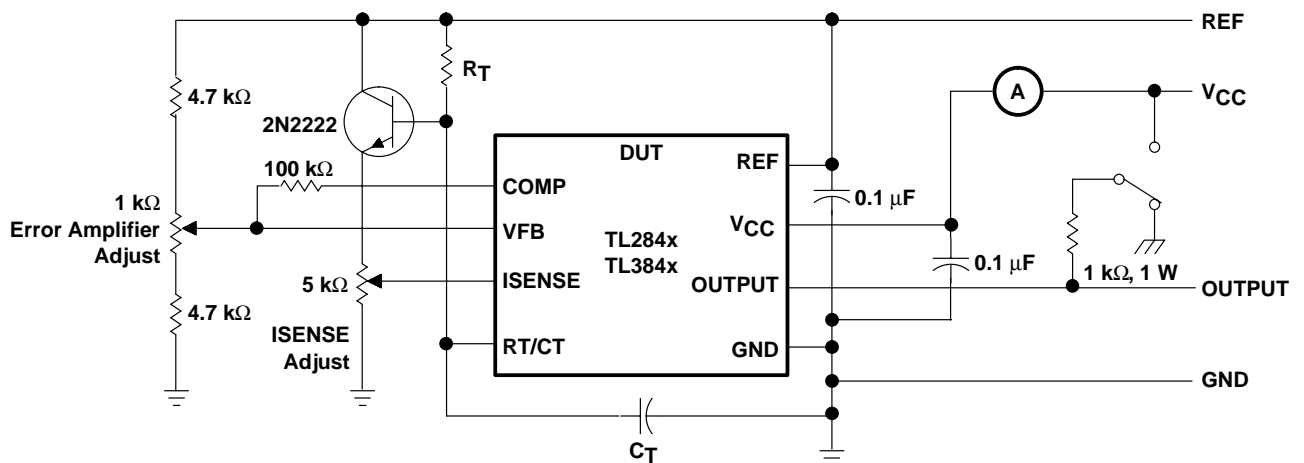

Figure 6. Open-Loop Laboratory Test Fixture

APPLICATION INFORMATION

shutdown technique

The PWM controller (see Figure 7) can be shut down by two methods: either raise the voltage at ISENSE above 1 V or pull the COMP terminal below a voltage two diode drops above ground. Either method causes the output of the PWM comparator to be high (refer to block diagram). The PWM latch is reset dominant so that the output remains low until the next clock cycle after the shutdown condition at the COMP or ISENSE terminal is removed. In one example, an externally latched shutdown can be accomplished by adding an SCR that resets by cycling V_{CC} below the lower UVLO threshold. At this point, the reference turns off, allowing the SCR to reset.

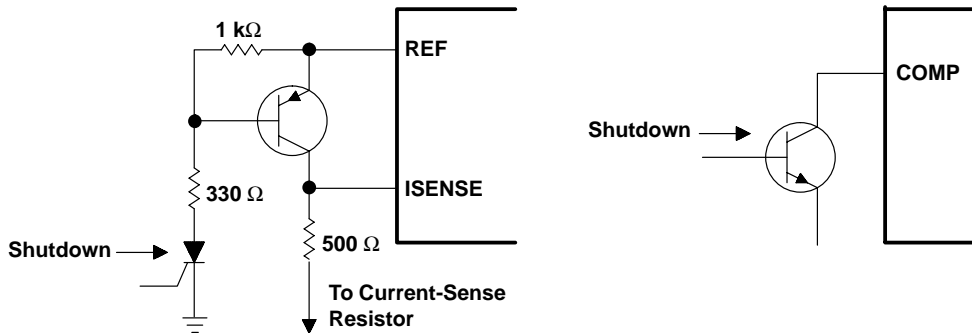

Figure 7. Shutdown Techniques

A fraction of the oscillator ramp can be summed resistively with the current-sense signal to provide slope compensation for converters requiring duty cycles over 50% (see Figure 8). Note that capacitor C forms a filter with R2 to suppress the leading-edge switch spikes.

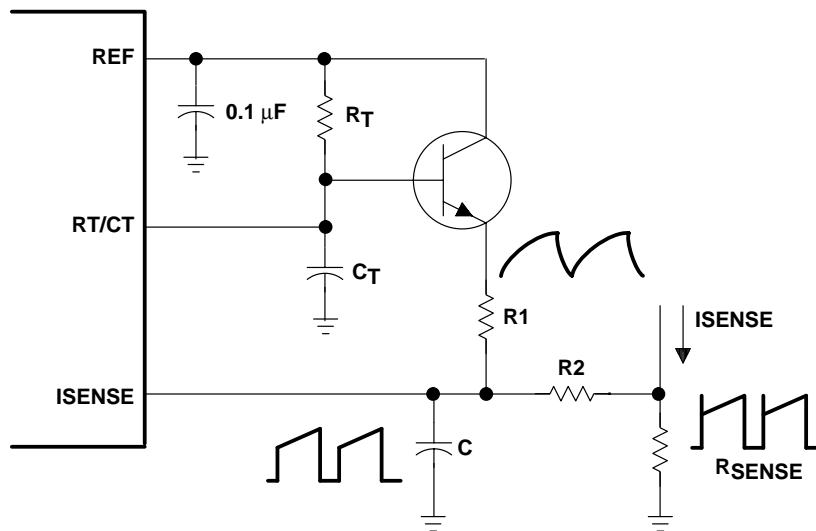

Figure 8. Slope Compensation

PACKAGING INFORMATION

Orderable Device	Status ⁽¹⁾	Package Type	Package Drawing	Pins	Package Qty	Eco Plan ⁽²⁾	Lead/Ball Finish	MSL Peak Temp ⁽³⁾
TL2842D	ACTIVE	SOIC	D	14	50	Pb-Free (RoHS)	CU NIPDAU	Level-2-250C-1 YEAR
TL2842D-8	ACTIVE	SOIC	D	8	75	Pb-Free (RoHS)	CU NIPDAU	Level-2-250C-1 YEAR
TL2842DR	ACTIVE	SOIC	D	14	2500	Pb-Free (RoHS)	CU NIPDAU	Level-2-250C-1 YEAR
TL2842DR-8	ACTIVE	SOIC	D	8	2500	Pb-Free (RoHS)	CU NIPDAU	Level-2-250C-1 YEAR
TL2842P	ACTIVE	PDIP	P	8	50	Pb-Free (RoHS)	CU NIPDAU	Level-NC-NC-NC
TL2843D	ACTIVE	SOIC	D	14	50	Pb-Free (RoHS)	CU NIPDAU	Level-2-250C-1 YEAR
TL2843D-8	ACTIVE	SOIC	D	8	75	Pb-Free (RoHS)	CU NIPDAU	Level-2-250C-1 YEAR
TL2843DR	ACTIVE	SOIC	D	14	2500	Pb-Free (RoHS)	CU NIPDAU	Level-2-250C-1 YEAR
TL2843DR-8	ACTIVE	SOIC	D	8	2500	Pb-Free (RoHS)	CU NIPDAU	Level-2-250C-1 YEAR
TL2843P	ACTIVE	PDIP	P	8	50	Pb-Free (RoHS)	CU NIPDAU	Level-NC-NC-NC
TL2844D	ACTIVE	SOIC	D	14	50	Pb-Free (RoHS)	CU NIPDAU	Level-2-250C-1 YEAR
TL2844D-8	ACTIVE	SOIC	D	8	75	Pb-Free (RoHS)	CU NIPDAU	Level-2-250C-1 YEAR
TL2844DR	ACTIVE	SOIC	D	14	2500	Pb-Free (RoHS)	CU NIPDAU	Level-2-250C-1 YEAR
TL2844DR-8	ACTIVE	SOIC	D	8	2500	Pb-Free (RoHS)	CU NIPDAU	Level-2-250C-1 YEAR
TL2844P	ACTIVE	PDIP	P	8	50	Pb-Free (RoHS)	CU NIPDAU	Level-NC-NC-NC
TL2845D	ACTIVE	SOIC	D	14	50	Pb-Free (RoHS)	CU NIPDAU	Level-2-250C-1 YEAR
TL2845D-8	ACTIVE	SOIC	D	8	75	Pb-Free (RoHS)	CU NIPDAU	Level-2-250C-1 YEAR
TL2845DR	ACTIVE	SOIC	D	14	2500	Pb-Free (RoHS)	CU NIPDAU	Level-2-250C-1 YEAR
TL2845DR-8	ACTIVE	SOIC	D	8	2500	Pb-Free (RoHS)	CU NIPDAU	Level-2-250C-1 YEAR
TL2845P	ACTIVE	PDIP	P	8	50	Pb-Free (RoHS)	CU NIPDAU	Level-NC-NC-NC
TL3842D	ACTIVE	SOIC	D	14	50	Pb-Free (RoHS)	CU NIPDAU	Level-2-250C-1 YEAR
TL3842D-8	ACTIVE	SOIC	D	8	75	Pb-Free (RoHS)	CU NIPDAU	Level-2-250C-1 YEAR
TL3842DR	ACTIVE	SOIC	D	14	2500	Pb-Free (RoHS)	CU NIPDAU	Level-2-250C-1 YEAR
TL3842DR-8	ACTIVE	SOIC	D	8	2500	Pb-Free (RoHS)	CU NIPDAU	Level-2-250C-1 YEAR
TL3842P	ACTIVE	PDIP	P	8	50	Pb-Free (RoHS)	CU NIPDAU	Level-NC-NC-NC

Orderable Device	Status ⁽¹⁾	Package Type	Package Drawing	Pins	Package Qty	Eco Plan ⁽²⁾	Lead/Ball Finish	MSL Peak Temp ⁽³⁾
TL3843D	ACTIVE	SOIC	D	14	50	Pb-Free (RoHS)	CU NIPDAU	Level-2-250C-1 YEAR
TL3843D-8	ACTIVE	SOIC	D	8	75	Pb-Free (RoHS)	CU NIPDAU	Level-2-250C-1 YEAR
TL3843DR	ACTIVE	SOIC	D	14	2500	Pb-Free (RoHS)	CU NIPDAU	Level-2-250C-1 YEAR
TL3843DR-8	ACTIVE	SOIC	D	8	2500	Pb-Free (RoHS)	CU NIPDAU	Level-2-250C-1 YEAR
TL3843P	ACTIVE	PDIP	P	8	50	Pb-Free (RoHS)	CU NIPDAU	Level-NC-NC-NC
TL3844D	ACTIVE	SOIC	D	14	50	Pb-Free (RoHS)	CU NIPDAU	Level-2-250C-1 YEAR
TL3844D-8	ACTIVE	SOIC	D	8	75	Pb-Free (RoHS)	CU NIPDAU	Level-2-250C-1 YEAR
TL3844DR	ACTIVE	SOIC	D	14	2500	Pb-Free (RoHS)	CU NIPDAU	Level-2-250C-1 YEAR
TL3844DR-8	ACTIVE	SOIC	D	8	2500	Pb-Free (RoHS)	CU NIPDAU	Level-2-250C-1 YEAR
TL3844P	ACTIVE	PDIP	P	8	50	Pb-Free (RoHS)	CU NIPDAU	Level-NC-NC-NC
TL3845D	ACTIVE	SOIC	D	14	50	Pb-Free (RoHS)	CU NIPDAU	Level-2-250C-1 YEAR
TL3845D-8	ACTIVE	SOIC	D	8	75	Pb-Free (RoHS)	CU NIPDAU	Level-2-250C-1 YEAR
TL3845DR	ACTIVE	SOIC	D	14	2500	Pb-Free (RoHS)	CU NIPDAU	Level-2-250C-1 YEAR
TL3845DR-8	ACTIVE	SOIC	D	8	2500	Pb-Free (RoHS)	CU NIPDAU	Level-2-250C-1 YEAR
TL3845P	ACTIVE	PDIP	P	8	50	Pb-Free (RoHS)	CU NIPDAU	Level-NC-NC-NC

⁽¹⁾ The marketing status values are defined as follows:

ACTIVE: Product device recommended for new designs.

LIFEBUY: TI has announced that the device will be discontinued, and a lifetime-buy period is in effect.

NRND: Not recommended for new designs. Device is in production to support existing customers, but TI does not recommend using this part in a new design.

PREVIEW: Device has been announced but is not in production. Samples may or may not be available.

OBSOLETE: TI has discontinued the production of the device.

⁽²⁾ Eco Plan - May not be currently available - please check <http://www.ti.com/productcontent> for the latest availability information and additional product content details.

None: Not yet available Lead (Pb-Free).

Pb-Free (RoHS): TI's terms "Lead-Free" or "Pb-Free" mean semiconductor products that are compatible with the current RoHS requirements for all 6 substances, including the requirement that lead not exceed 0.1% by weight in homogeneous materials. Where designed to be soldered at high temperatures, TI Pb-Free products are suitable for use in specified lead-free processes.

Green (RoHS & no Sb/Br): TI defines "Green" to mean "Pb-Free" and in addition, uses package materials that do not contain halogens, including bromine (Br) or antimony (Sb) above 0.1% of total product weight.

⁽³⁾ MSL, Peak Temp. -- The Moisture Sensitivity Level rating according to the JEDEC industry standard classifications, and peak solder temperature.

Important Information and Disclaimer: The information provided on this page represents TI's knowledge and belief as of the date that it is provided. TI bases its knowledge and belief on information provided by third parties, and makes no representation or warranty as to the accuracy of such information. Efforts are underway to better integrate information from third parties. TI has taken and continues to take reasonable steps to provide representative and accurate information but may not have conducted destructive testing or chemical analysis on

incoming materials and chemicals. TI and TI suppliers consider certain information to be proprietary, and thus CAS numbers and other limited information may not be available for release.

In no event shall TI's liability arising out of such information exceed the total purchase price of the TI part(s) at issue in this document sold by TI to Customer on an annual basis.

P (R-PDIP-T8)

PLASTIC DUAL-IN-LINE



- NOTES: A. All linear dimensions are in inches (millimeters).
 B. This drawing is subject to change without notice.
 C. Falls within JEDEC MS-001

For the latest package information, go to http://www.ti.com/sc/docs/package/pkg_info.htm



D (R-PDSO-G14)

PLASTIC SMALL-OUTLINE PACKAGE

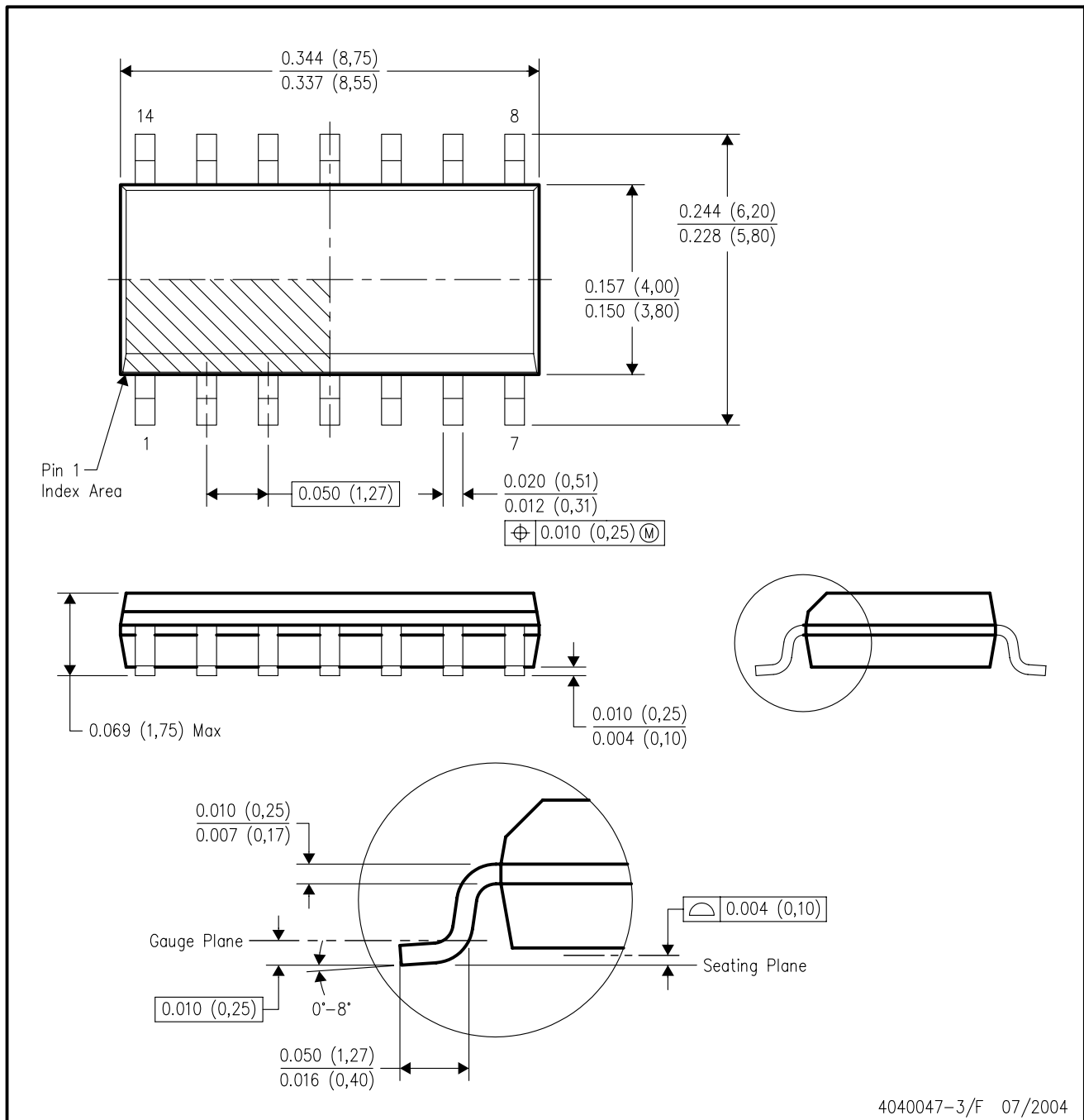

- NOTES:
- A. All linear dimensions are in inches (millimeters).
 - B. This drawing is subject to change without notice.
 - C. Body dimensions do not include mold flash or protrusion not to exceed 0.006 (0,15).
 - D. Falls within JEDEC MS-012 variation AB.

IMPORTANT NOTICE

Texas Instruments Incorporated and its subsidiaries (TI) reserve the right to make corrections, modifications, enhancements, improvements, and other changes to its products and services at any time and to discontinue any product or service without notice. Customers should obtain the latest relevant information before placing orders and should verify that such information is current and complete. All products are sold subject to TI's terms and conditions of sale supplied at the time of order acknowledgment.

TI warrants performance of its hardware products to the specifications applicable at the time of sale in accordance with TI's standard warranty. Testing and other quality control techniques are used to the extent TI deems necessary to support this warranty. Except where mandated by government requirements, testing of all parameters of each product is not necessarily performed.

TI assumes no liability for applications assistance or customer product design. Customers are responsible for their products and applications using TI components. To minimize the risks associated with customer products and applications, customers should provide adequate design and operating safeguards.

TI does not warrant or represent that any license, either express or implied, is granted under any TI patent right, copyright, mask work right, or other TI intellectual property right relating to any combination, machine, or process in which TI products or services are used. Information published by TI regarding third-party products or services does not constitute a license from TI to use such products or services or a warranty or endorsement thereof. Use of such information may require a license from a third party under the patents or other intellectual property of the third party, or a license from TI under the patents or other intellectual property of TI.

Reproduction of information in TI data books or data sheets is permissible only if reproduction is without alteration and is accompanied by all associated warranties, conditions, limitations, and notices. Reproduction of this information with alteration is an unfair and deceptive business practice. TI is not responsible or liable for such altered documentation.

Resale of TI products or services with statements different from or beyond the parameters stated by TI for that product or service voids all express and any implied warranties for the associated TI product or service and is an unfair and deceptive business practice. TI is not responsible or liable for any such statements.

Following are URLs where you can obtain information on other Texas Instruments products and application solutions:

Products		Applications	
Amplifiers	amplifier.ti.com	Audio	www.ti.com/audio
Data Converters	dataconverter.ti.com	Automotive	www.ti.com/automotive
DSP	dsp.ti.com	Broadband	www.ti.com/broadband
Interface	interface.ti.com	Digital Control	www.ti.com/digitalcontrol
Logic	logic.ti.com	Military	www.ti.com/military
Power Mgmt	power.ti.com	Optical Networking	www.ti.com/opticalnetwork
Microcontrollers	microcontroller.ti.com	Security	www.ti.com/security
		Telephony	www.ti.com/telephony
		Video & Imaging	www.ti.com/video
		Wireless	www.ti.com/wireless

Mailing Address: Texas Instruments
Post Office Box 655303 Dallas, Texas 75265