

TL441AM LOGARITHMIC AMPLIFIER

SLFS038 – JUNE 1976 – REVISED FEBRUARY 1989

- Excellent Dynamic Range
- Wide Bandwidth
- Built-In Temperature Compensation
- Log Linearity (30 dB Sections) . . . 1 dB Typ
- Wide Input Voltage Range

description

This monolithic amplifier circuit contains four 30-dB logarithmic stages. Gain in each stage is such that the output of each stage is proportional to the logarithm of the input voltage over the 30-dB input voltage range. Each half of the circuit contains two of these 30-dB stages summed together in one differential output that is proportional to the sum of the logarithms of the input voltages of the two stages. The four stages may be interconnected to obtain a theoretical input voltage range of 120-dB. In practice, this permits the input voltage range to be typically greater than 80-dB with log linearity of ± 0.5 -dB (see application data). Bandwidth is from dc to 40 MHz.

This circuit is useful in military weapons systems, broadband radar, and infrared reconnaissance systems. It serves for data compression and analog compensation. This logarithmic amplifier is used in log IF circuitry as well as video and log amplifiers. The TL441AM is characterized for operation over the full military temperature range of -55°C to 125°C .

J PACKAGE
(TOP VIEW)

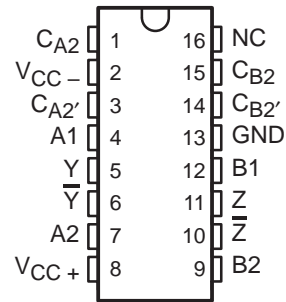

FK PACKAGE
(TOP VIEW)

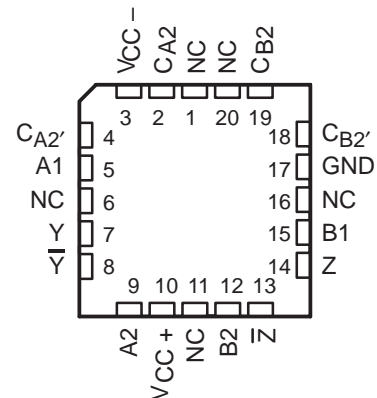

NC — No internal connection

functional block diagram (one half)

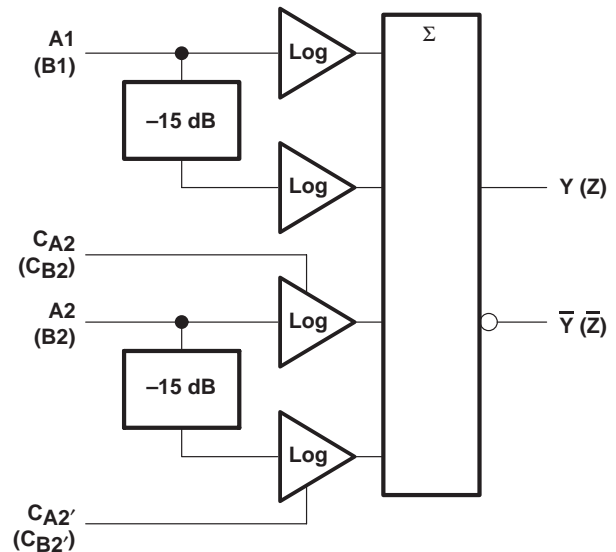

$$Y \propto \log A1 + \log A2; Z \propto \log B1 + \log B2$$

where: A1, A2, B1, and B2 are in dBV, 0 dBV = 1 V.
CA2, CA2', CB2, and CB2' are detector compensation inputs.

TL441AM LOGARITHMIC AMPLIFIER

SLFS038 – JUNE 1976 – REVISED FEBRUARY 1989

schematic

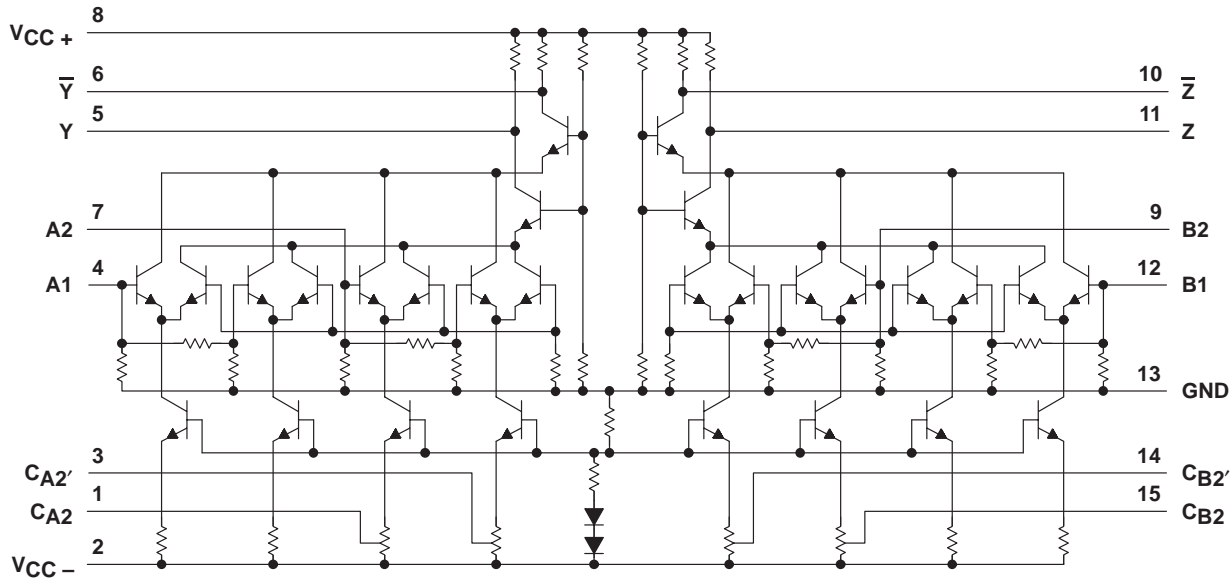

Pin numbers shown are for the J package.

absolute maximum ratings over operating free-air temperature range (unless otherwise noted)†

Supply voltages (see Note 1): V_{CC+}	8 V
V_{CC-}	-8 V
Input voltage (see Note 1)	6 V
Output sink current (any one output)	30 mA
Continuous total dissipation	See Dissipation Rating Table
Operating free-air temperature range	-55°C to 125°C
Storage temperature range	-65°C to 150°C
Case temperature for 60 seconds: FK package	260°C
Lead temperature 1,6 mm (1/16 inch) from case for 60 seconds: J package	300°C

† Stresses beyond those listed under absolute maximum ratings may cause permanent damage to the device. This is a stress rating only, and functional operation of the device at these or any other conditions beyond those indicated in the recommended operating conditions section of this specification is not implied. Exposure to absolute-maximum-rated conditions for extended periods may affect device reliability.

NOTE 1: All voltages, except differential output voltages, are with respect to network ground terminal.

DISSIPATION RATING TABLE

PACKAGE	$T_A \leq 25^\circ\text{C}$ POWER RATING	DERATING FACTOR	DERATE ABOVE T_A	$T_A = 70^\circ\text{C}$ POWER RATING	$T_A = 125^\circ\text{C}$ POWER RATING
FK	500 mW	11.0 mW/°C	104°C	500 mW	275 mW
J	500 mW	11.0 mW/°C	104°C	500 mW	275 mW

recommended operating conditions

	MIN	MAX	UNIT
Peak-to-peak input voltage for each 30-dB stage	0.01	1	V
Operating free-air temperature, T_A	-55	125	°C



POST OFFICE BOX 655303 • DALLAS, TEXAS 75265

electrical characteristics, $V_{CC\pm} = \pm 6\text{ V}$, $T_A = 25^\circ\text{C}$

PARAMETER	TEST FIGURE	MIN	TYP	MAX	UNIT
Differential output offset voltage	1		± 25	± 70	mV
Quiescent output voltage	2	5.45	5.6	5.85	V
DC scale factor (differential output), each 3-dB stage, -35 dBV to -5 dBV	3	7	8	11	mV/dB
AC scale factor (differential output)			8		mV/dB
DC error at -20 dBV (midpoint of -35 dBV to -5 dBV range)	3		1	2.6	dB
Input impedance			500		Ω
Output impedance			200		Ω
Rise time, 10% to 90% points, $C_L = 24\text{ pF}$	4		20	35	ns
Supply current from V_{CC+}	2	14.5	18.5	23	mA
Supply current from V_{CC-}	2	-6	-8.5	-10.5	mA
Power dissipation	2	123	162	201	mW

electrical characteristics over operating free-air temperature range, $V_{CC\pm} = \pm 6\text{ V}$ (unless otherwise noted)

PARAMETER	TEST FIGURE	MIN	MAX	UNIT
Differential output offset voltage	1		± 100	mV
Quiescent output voltage	2	5.3	5.85	V
DC scale factor (differential output) each 30-dB stage, -35 dBV to -5 dBV	3	7	11	mV/dB
DC error at -20 dBV (midpoint of -35 dBV to -5 dBV range)	3		4	dB
		$T_A = -55^\circ\text{C}$	3	
Supply current from V_{CC+}	2	10	31	mA
Supply current from V_{CC-}	2	-4.5	-15	mA
Power dissipation	2	87	276	mW

PARAMETER MEASUREMENT INFORMATION

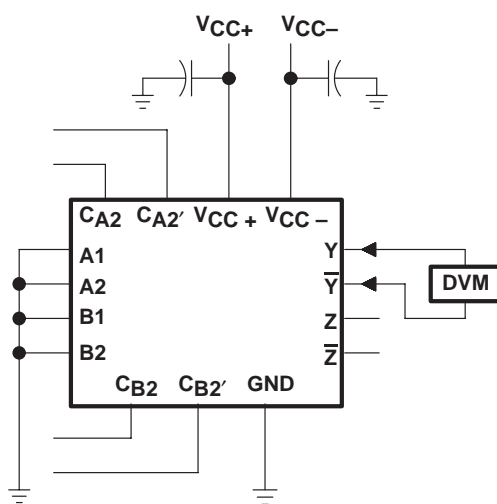

Figure 1

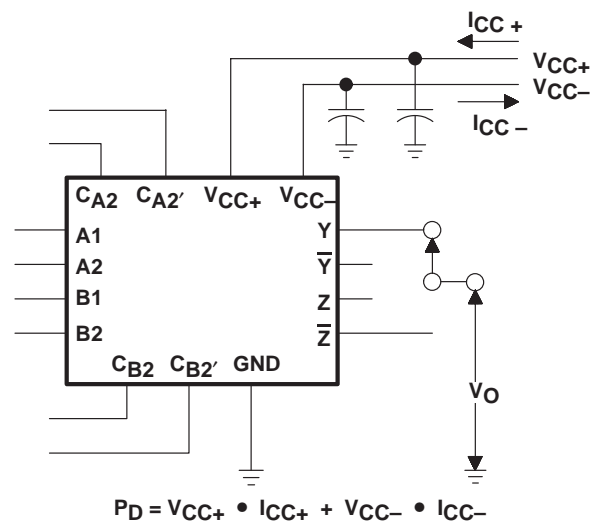

Figure 2

TL441AM LOGARITHMIC AMPLIFIER

SLFS038 – JUNE 1976 – REVISED FEBRUARY 1989

PARAMETER MEASUREMENT INFORMATION

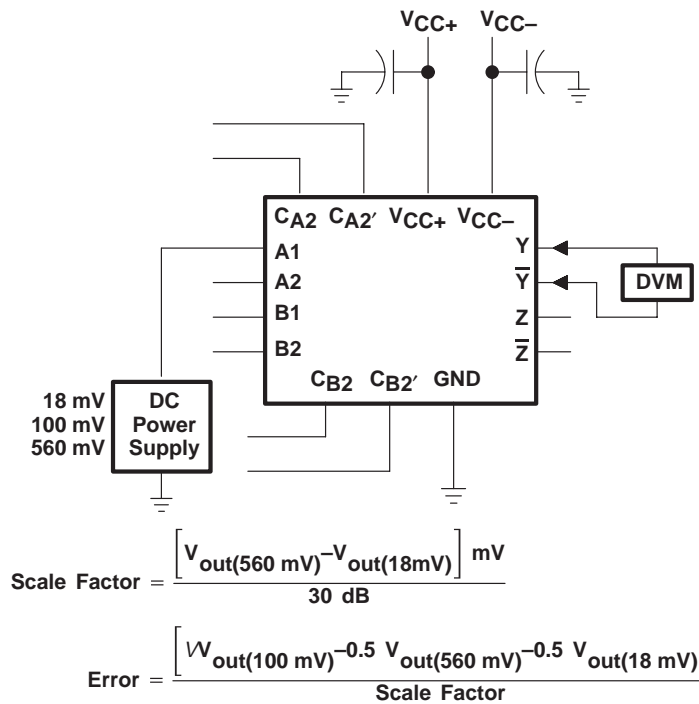
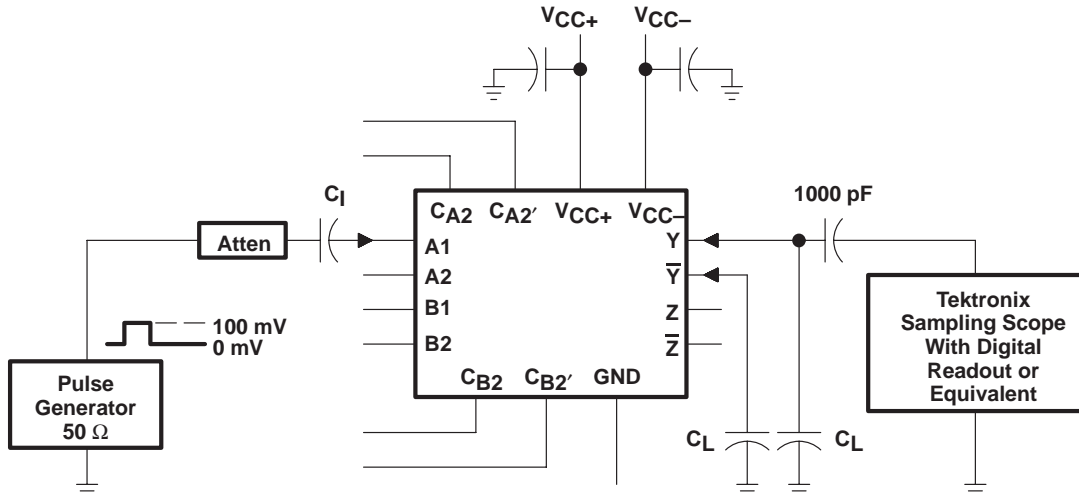

Figure 3



- NOTES: A. The input pulse has the following characteristics: $t_w = 200 \text{ ns}$, $t_r \leq 2 \text{ ns}$, $t_f \leq 2 \text{ ns}$, $\text{PRR} \leq 10 \text{ MHz}$.
 B. Capacitor C_1 consists of three capacitors in parallel: $1 \mu\text{F}$, $0.1 \mu\text{F}$, and $0.01 \mu\text{F}$.
 C. C_L includes probe and jig capacitance.

Figure 4

TYPICAL CHARACTERISTICS

DIFFERENTIAL OUTPUT OFFSET VOLTAGE
vs
FREE-AIR TEMPERATURE

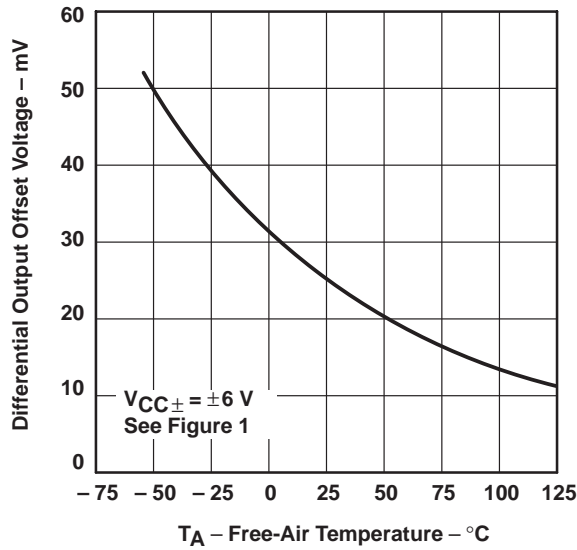

Figure 5

QUIESCENT OUTPUT VOLTAGE
vs
FREE-AIR TEMPERATURE

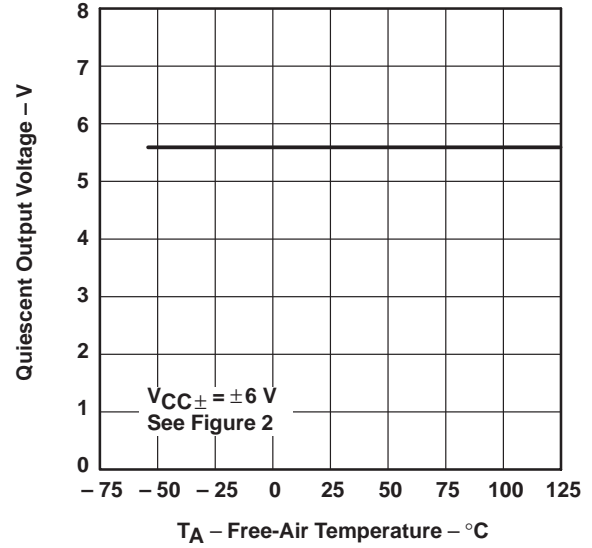

Figure 6

DC SCALE FACTOR
vs
FREE-AIR TEMPERATURE

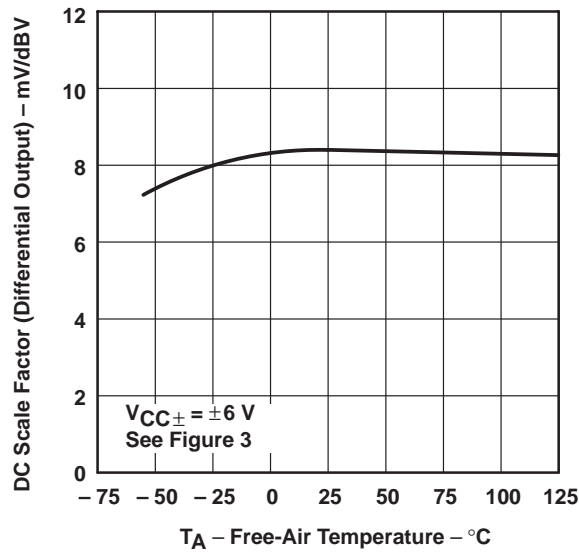

Figure 7

DC ERROR
vs
FREE-AIR TEMPERATURE

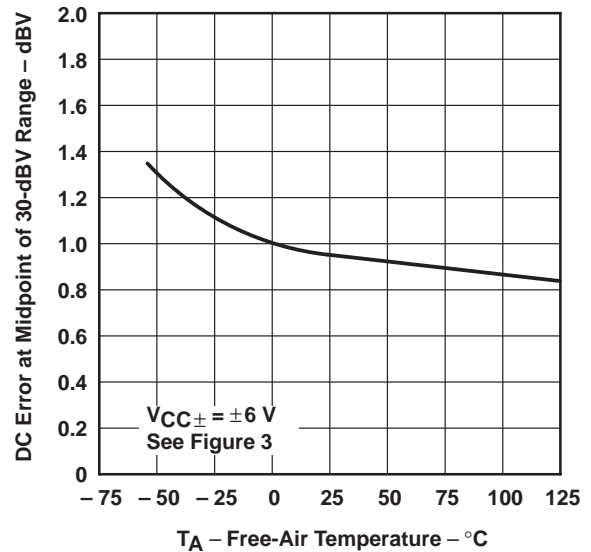

Figure 8

TL441AM LOGARITHMIC AMPLIFIER

SLFS038 – JUNE 1976 – REVISED FEBRUARY 1989

TYPICAL CHARACTERISTICS

OUTPUT RISE TIME VS LOAD CAPACITANCE

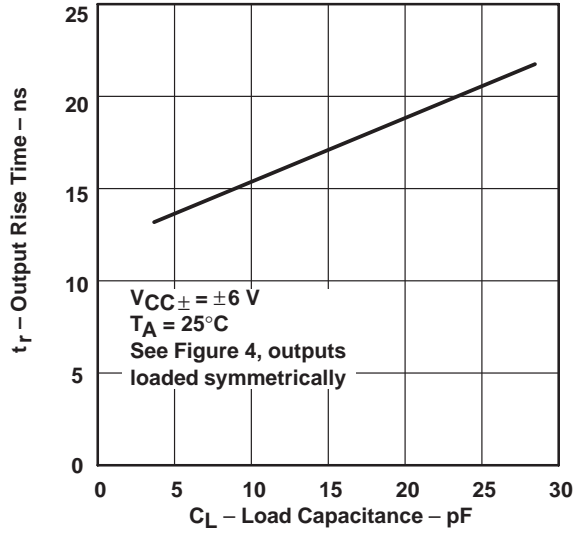

Figure 9

POWER DISSIPATION VS FREE-AIR TEMPERATURE

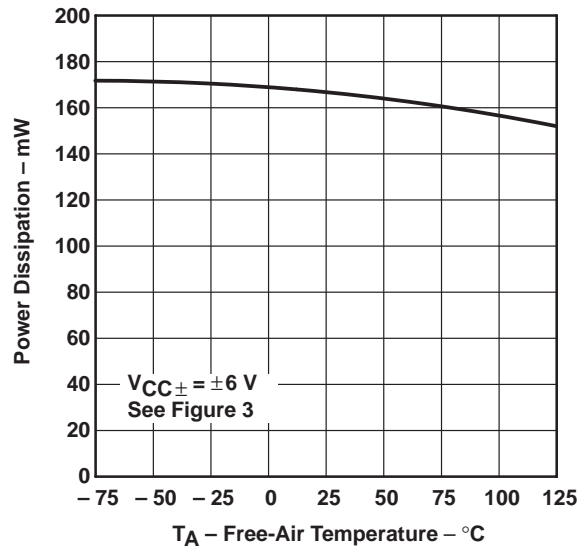

Figure 10

APPLICATION INFORMATION

Although designed for high-performance applications such as broadband radar, infrared detection and weapons systems, this device has a wide range of applications in data compression and analog computation.

basic logarithmic function

The basic logarithmic response is derived from the exponential current-voltage relationship of collector current and base-emitter voltage. This relationship is given in the equation:

$$m \cdot V_{BE} = \ln [(I_C + I_{CES})/I_{CES}]$$

where:

I_C = collector current

I_{CES} = collector current at $V_{BE} = 0$

$m = q/kT$ (in V^{-1})

V_{BE} = base-emitter voltage

The differential input amplifier allows dual-polarity inputs, is self-compensating for temperature variations, and is relatively insensitive to common-mode noise.

functional block diagram

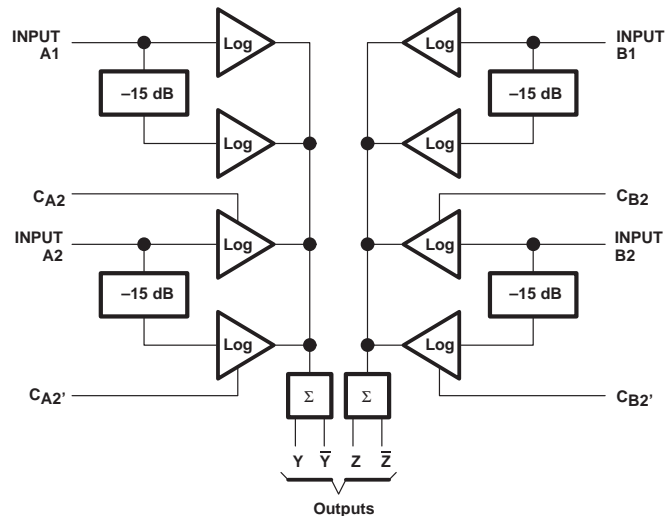

Figure 11

logarithmic sections

As can be seen from the schematic, there are eight differential pairs. Each pair is a 15-dB log subsection, and each input feeds two pairs for a range of 30-dB per stage.

Four compensation points are made available to allow slight variations in the gain (slope) of the two individual 15-dB stages of input A2 and B2. By slightly changing the voltage on any of the compensation pins from its quiescent value, the gain of that particular 15-dB stage can be adjusted to match the other 15-dB stage in the pair. The compensation pins may also be used to match the transfer characteristics of input A2 to A1 or B2 to B1.

The log stages in each half of the circuit are summed by directly connecting their collectors together and summing through a common-base output stage. The two sets of output collectors are used to give two log outputs, Y and \bar{Y} (or Z and \bar{Z}) which are equal in amplitude but opposite in polarity. This increases the versatility of the device.

By proper choice of external connections, linear amplification, and linear attenuation, and many different applications requiring logarithmic signal processing are possible.

input levels

The recommended input voltage range of any one stage is given as 0.01 V to 1 V. Input levels in excess of 1 V may result in a distorted output. When several log sections are summed together, the distorted area of one section overlaps with the next section and the resulting distortion is insignificant. However, there is a limit to the amount of overdrive that may be applied. As the input drive reaches ± 3.5 V, saturation occurs, clamping the collector-summing line and severely distorting the output. Therefore, the signal to any input must be limited to approximately ± 3 V to ensure a clean output.

TL441AM LOGARITHMIC AMPLIFIER

SLFS038 – JUNE 1976 – REVISED FEBRUARY 1989

APPLICATION INFORMATION

output levels

Differential-output-voltage levels are low, generally less than 0.6 V. As demonstrated in Figure 12, the output swing and the slope of the output response can be adjusted by varying the gain by means of the slope control. The coordinate origin may also be adjusted by positioning the offset of the output buffer.

circuits

Figures 12 through 19 show typical circuits using this logarithmic amplifier. Operational amplifiers not otherwise designated are TLC271. For operation at higher frequencies, the TL592 is recommended instead of the TLC271.

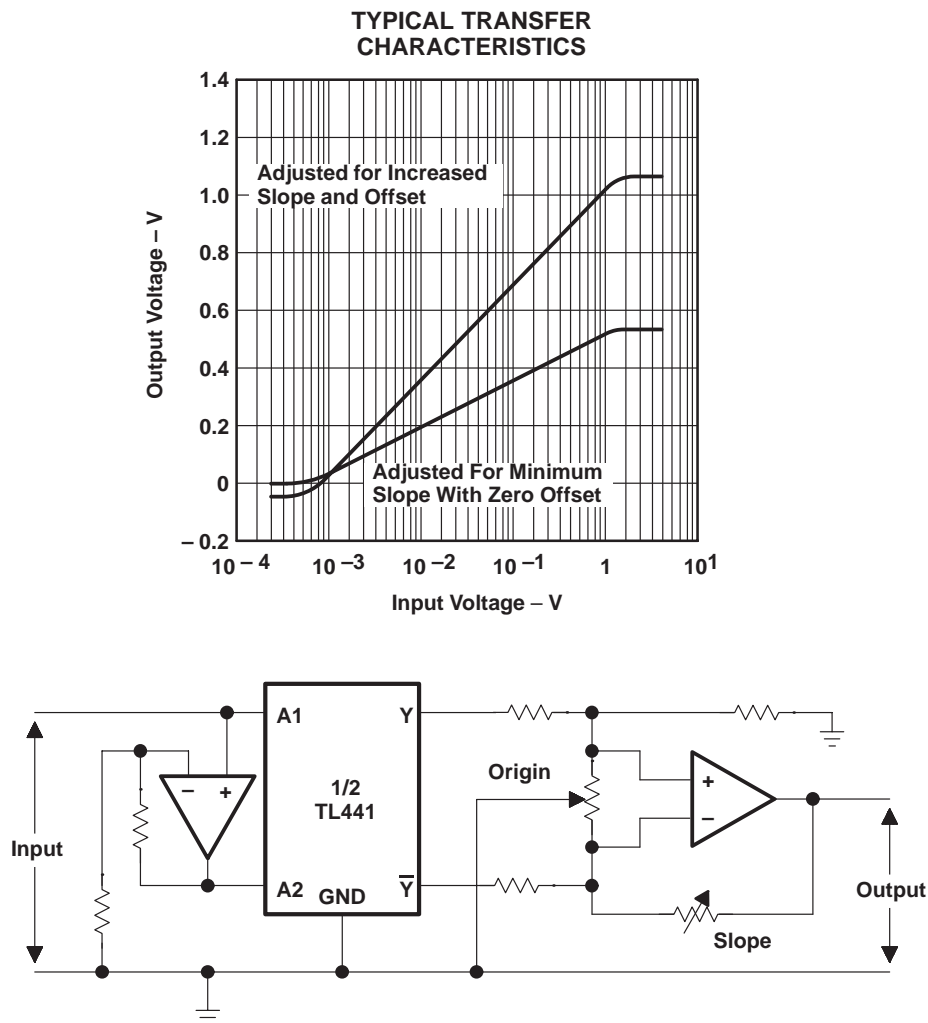

Figure 12. Output Slope and Origin Adjustment

APPLICATION INFORMATION

TRANSFER CHARACTERISTICS
OF TWO TYPICAL INPUT STAGES

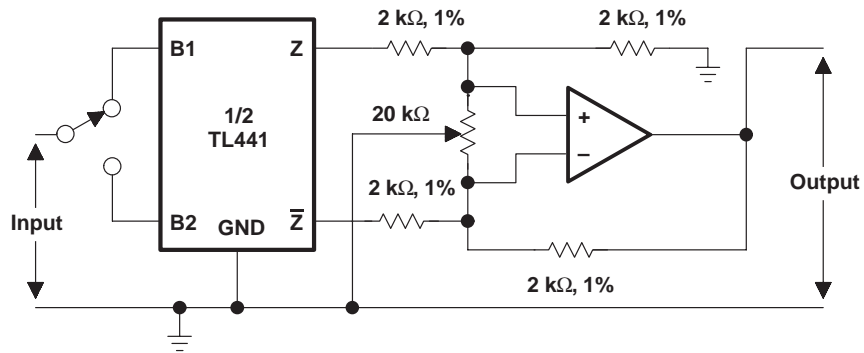
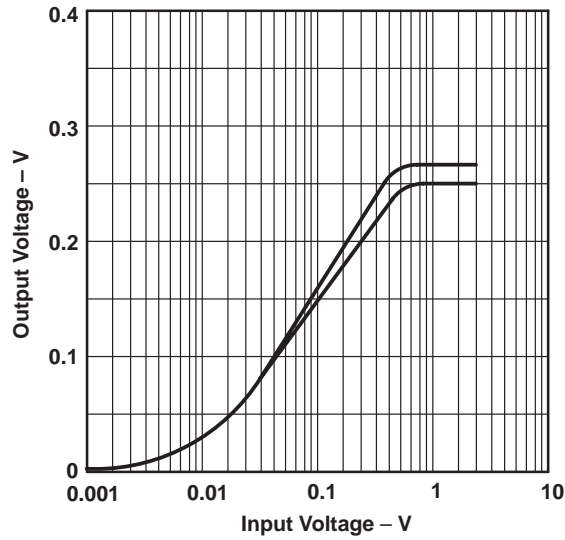

Figure 13. Utilization of Separate Stages

TL441AM LOGARITHMIC AMPLIFIER

SLFS038 – JUNE 1976 – REVISED FEBRUARY 1989

APPLICATION INFORMATION

TRANSFER CHARACTERISTICS WITH BOTH SIDES PARALLELED

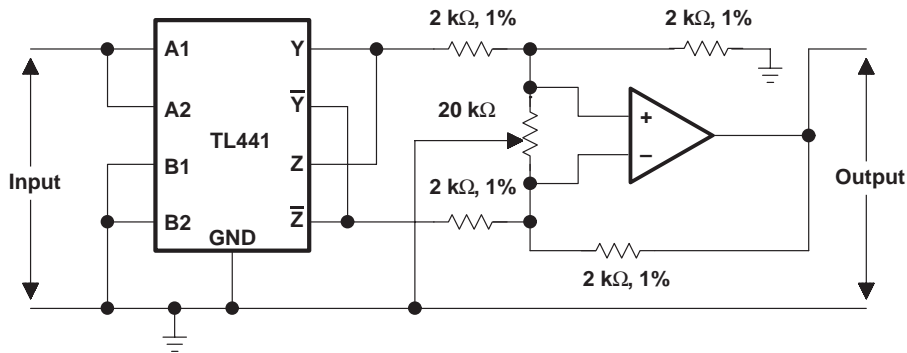
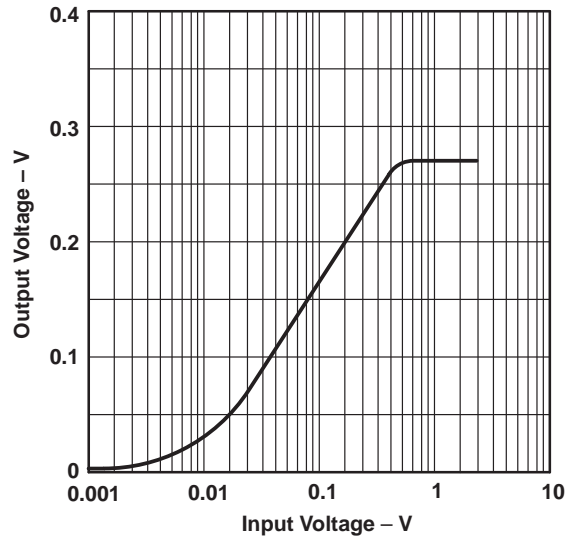
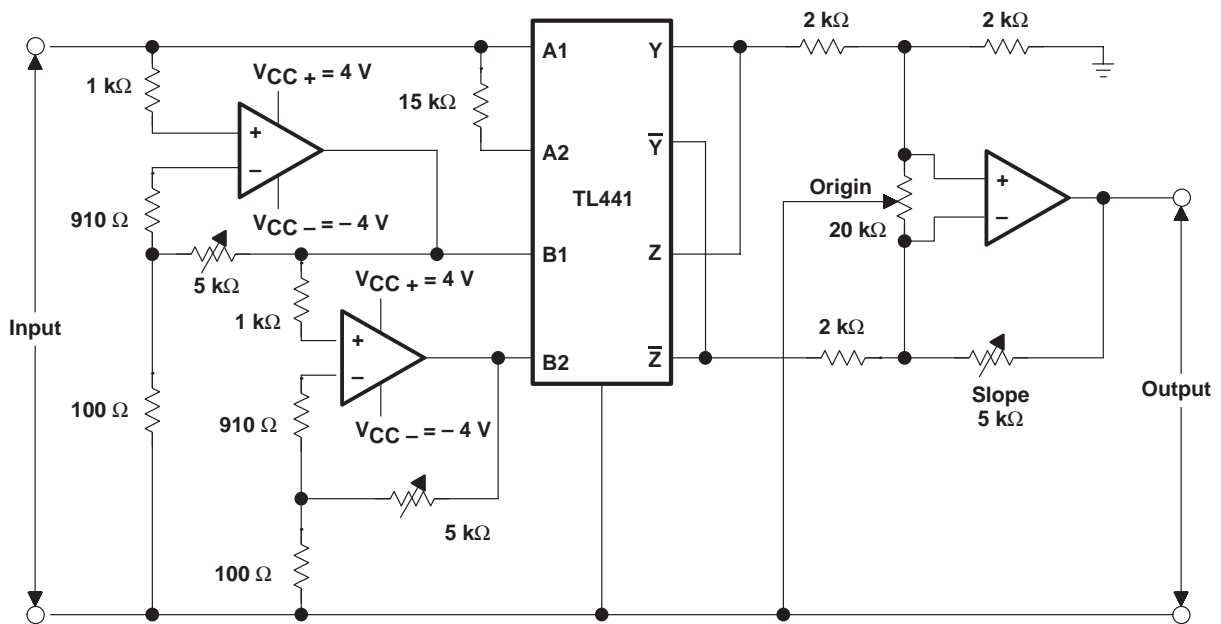
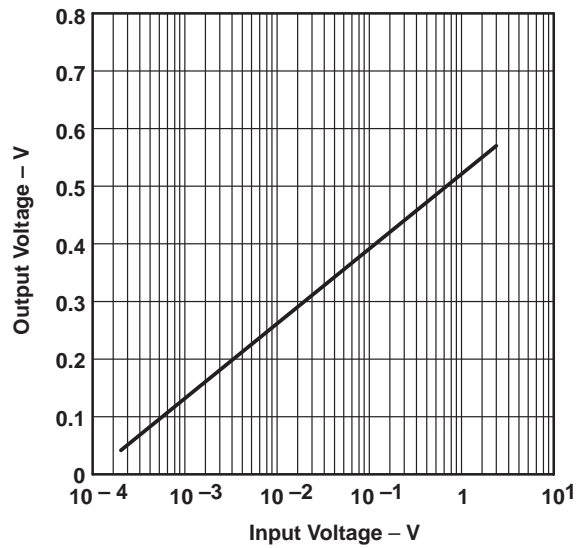

Figure 14. Utilization of Paralleled Inputs

APPLICATION INFORMATION

TRANSFER CHARACTERISTICS



- NOTES: A. Inputs are limited by reducing the supply voltages for the input amplifiers to ± 4 V.
B. The gains of the input amplifiers are adjusted to achieve smooth transitions.

Figure 15. Logarithmic Amplifier With Input Voltage Range Greater Than 80 dB

TL441AM LOGARITHMIC AMPLIFIER

SLFS038 – JUNE 1976 – REVISED FEBRUARY 1989

APPLICATION INFORMATION

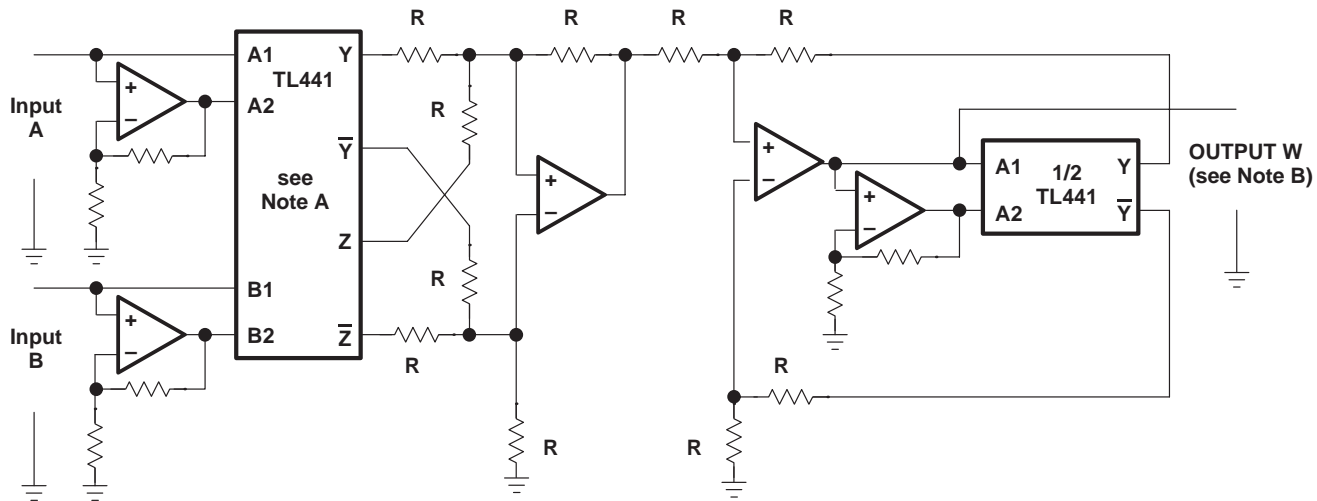

- NOTES: A. Connections shown are for multiplication. For division, Z and \bar{Z} connections are reversed.
 B. Output W may need to be amplified to give actual product or quotient of A and B.
 C. R designates resistors of equal value, typically 2 k Ω to 10 k Ω .

Multiplication: $W = A \cdot B \Rightarrow \log W = \log A + \log B$, or $W = a^{(\log_a A + \log_a B)}$

Division: $W = A/B \Rightarrow \log W = \log A - \log B$, or $W = a^{(\log_a A - \log_a B)}$

Figure 16. Multiplication or Division

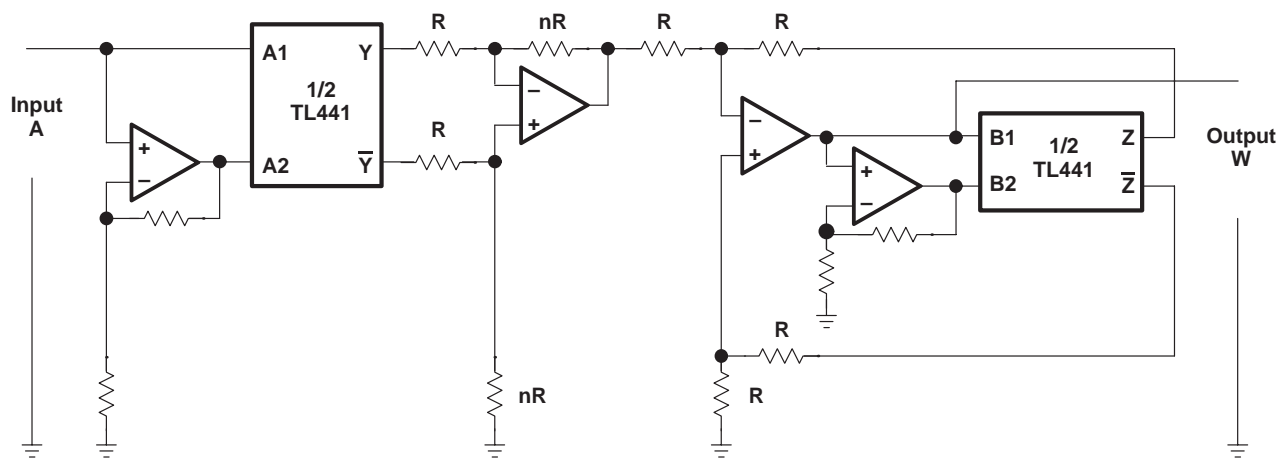

NOTE: R designates resistors of equal value, typically 2 k Ω to 10 k Ω . The power to which the input variable is raised is fixed by setting nR. Output W may need to be amplified to give the correct value.

Exponential: $W = A^n \Rightarrow \log W = n \log A$, or $W = a^{(n \log_a A)}$

Figure 17. Raising a Variable to a Fixed Power

APPLICATION INFORMATION

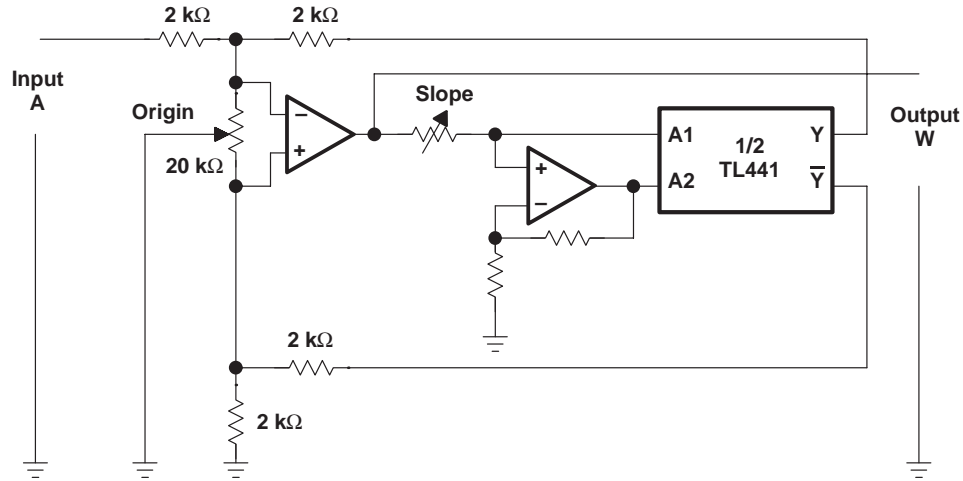

NOTE: Adjust the slope to correspond to the base "a".
Exponential to any base: $W = a$.

Figure 18. Raising a Fixed Number to a Variable Power

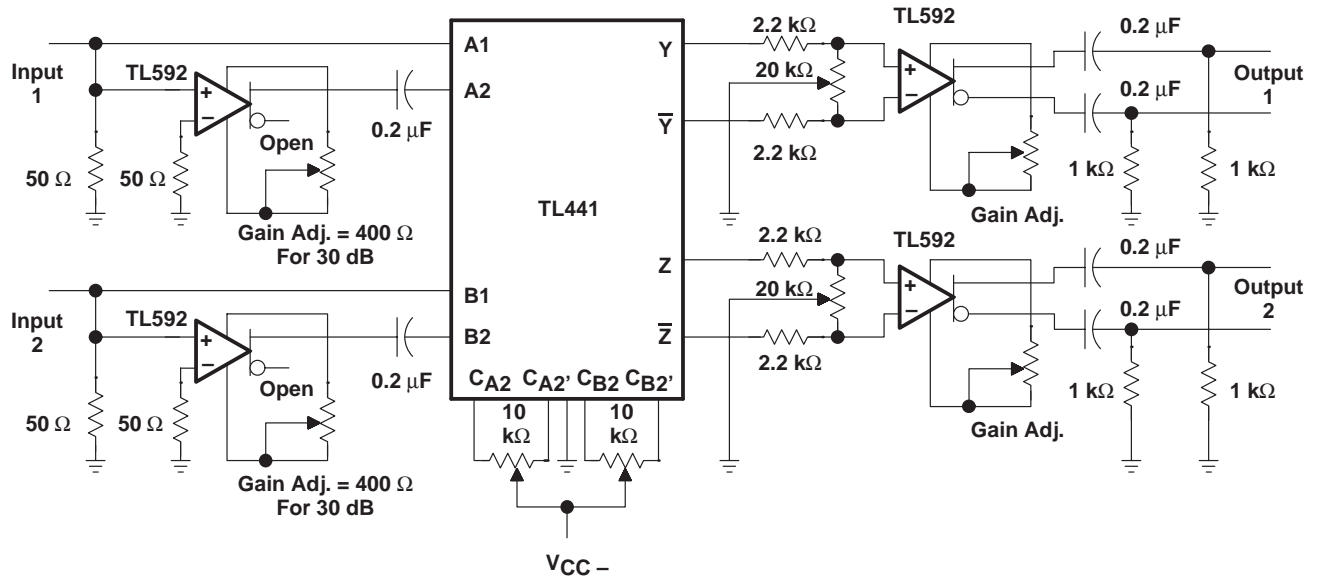

Figure 19. Dual-Channel RF Logarithmic Amplifier With 50-dB Input Range Per Channel at 10 MHz

IMPORTANT NOTICE

Texas Instruments and its subsidiaries (TI) reserve the right to make changes to their products or to discontinue any product or service without notice, and advise customers to obtain the latest version of relevant information to verify, before placing orders, that information being relied on is current and complete. All products are sold subject to the terms and conditions of sale supplied at the time of order acknowledgement, including those pertaining to warranty, patent infringement, and limitation of liability.

TI warrants performance of its semiconductor products to the specifications applicable at the time of sale in accordance with TI's standard warranty. Testing and other quality control techniques are utilized to the extent TI deems necessary to support this warranty. Specific testing of all parameters of each device is not necessarily performed, except those mandated by government requirements.

CERTAIN APPLICATIONS USING SEMICONDUCTOR PRODUCTS MAY INVOLVE POTENTIAL RISKS OF DEATH, PERSONAL INJURY, OR SEVERE PROPERTY OR ENVIRONMENTAL DAMAGE ("CRITICAL APPLICATIONS"). TI SEMICONDUCTOR PRODUCTS ARE NOT DESIGNED, AUTHORIZED, OR WARRANTED TO BE SUITABLE FOR USE IN LIFE-SUPPORT DEVICES OR SYSTEMS OR OTHER CRITICAL APPLICATIONS. INCLUSION OF TI PRODUCTS IN SUCH APPLICATIONS IS UNDERSTOOD TO BE FULLY AT THE CUSTOMER'S RISK.

In order to minimize risks associated with the customer's applications, adequate design and operating safeguards must be provided by the customer to minimize inherent or procedural hazards.

TI assumes no liability for applications assistance or customer product design. TI does not warrant or represent that any license, either express or implied, is granted under any patent right, copyright, mask work right, or other intellectual property right of TI covering or relating to any combination, machine, or process in which such semiconductor products or services might be or are used. TI's publication of information regarding any third party's products or services does not constitute TI's approval, warranty or endorsement thereof.