

- **Controlled Baseline**
 - One Assembly/Test Site, One Fabrication Site
- **Extended Temperature Performance of –55°C to 125°C**
- **Enhanced Diminishing Manufacturing Sources (DMS) Support**
- **Enhanced Product-Change Notification**
- **Qualification Pedigree†**
- **Excellent Dynamic Range**
- **Wide Bandwidth**
- **Built-In Temperature Compensation**
- **Log Linearity (30-dB Sections) . . . 1 dB Typ**
- **Wide Input Voltage Range**

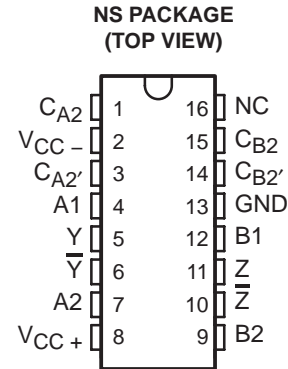

NC — No internal connection

† Component qualification in accordance with JEDEC and industry standards to ensure reliable operation over an extended temperature range. This includes, but is not limited to, Highly Accelerated Stress Test (HAST) or biased 85/85, temperature cycle, autoclave or unbiased HAST, electromigration, bond intermetallic life, and mold compound life. Such qualification testing should not be viewed as justifying use of this component beyond specified performance and environmental limits.

DESCRIPTION

This amplifier circuit contains four 30-dB logarithmic stages. Gain in each stage is such that the output of each stage is proportional to the logarithm of the input voltage over the 30-dB input voltage range. Each half of the circuit contains two of these 30-dB stages summed together in one differential output that is proportional to the sum of the logarithms of the input voltages of the two stages. The four stages may be interconnected to obtain a theoretical input voltage range of 120-dB. In practice, this permits the input voltage range typically to be greater than 80-dB with log linearity of ± 0.5 -dB (see application data). Bandwidth is from dc to 40 MHz.

This circuit is useful in data compression and analog compensation. This logarithmic amplifier is used in log IF circuitry as well as video and log amplifiers.

The TL441M is characterized for operation over the full military temperature range of -55°C to 125°C .

ORDERING INFORMATION

T _A	PACKAGE†	ORDERABLE PART NUMBER	TOP-SIDE MARKING
-55°C to 125°C	SOP (NS) Tape and reel	TL441MNSREP	TL441MEP

† Package drawings, standard packing quantities, thermal data, symbolization, and PCB design guidelines are available at www.ti.com/sc/package.



Please be aware that an important notice concerning availability, standard warranty, and use in critical applications of Texas Instruments semiconductor products and disclaimers thereto appears at the end of this data sheet.

PRODUCTION DATA information is current as of publication date. Products conform to specifications per the terms of Texas Instruments standard warranty. Production processing does not necessarily include testing of all parameters.

**TEXAS
INSTRUMENTS**

POST OFFICE BOX 655303 • DALLAS, TEXAS 75265

Copyright © 2004, Texas Instruments Incorporated

TL441-EP LOGARITHMIC AMPLIFIER

SGLS268 – OCTOBER 2004

FUNCTIONAL LOGIC DIAGRAM (one half)

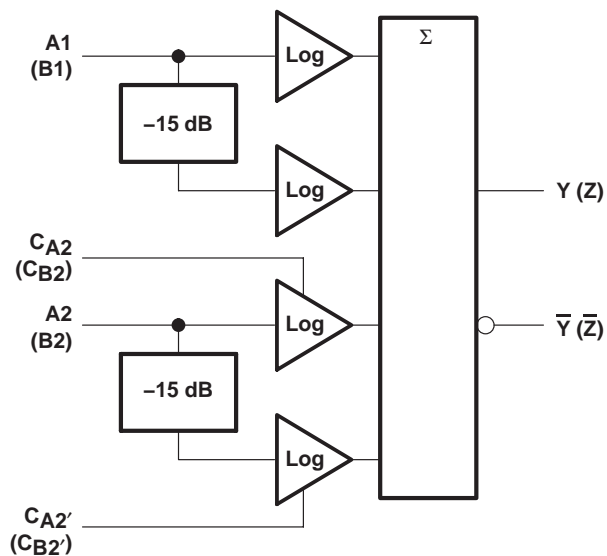

$Y \propto \log A1 + \log A2$; $Z \propto \log B1 + \log B2$ where: A1, A2, B1, and B2 are in dBV, 0 dBV = 1 V.
CA2, CA2', CB2, and CB2' are detector compensation inputs.

SCHEMATIC

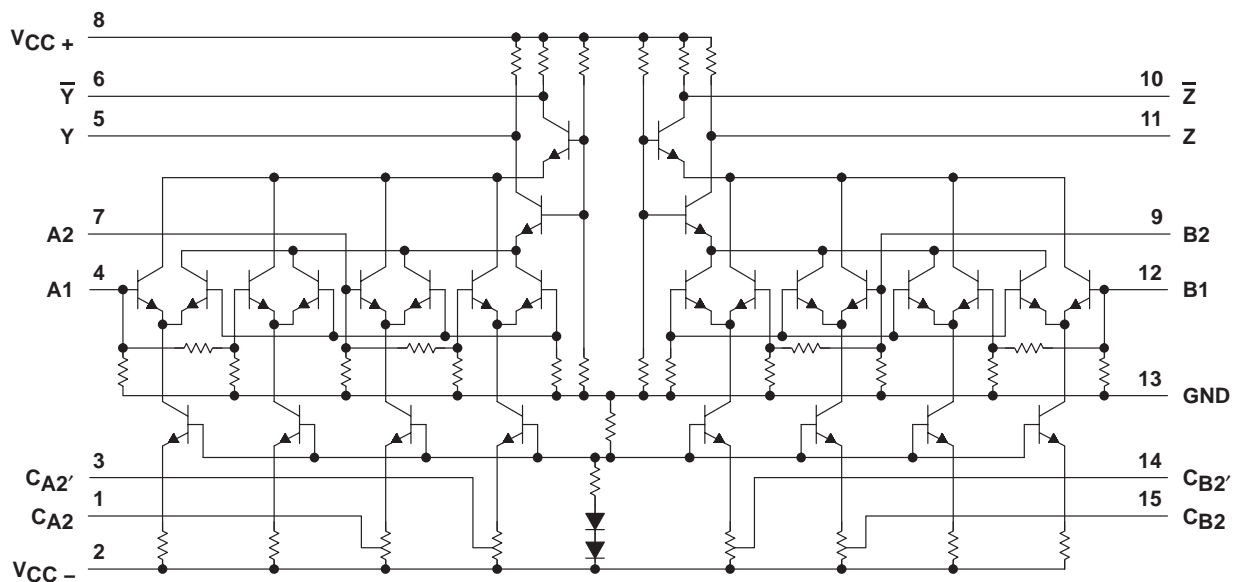

ABSOLUTE MAXIMUM RATINGS OVER OPERATING FREE-AIR TEMPERATURE RANGE (unless otherwise noted)†

		TL441-EP
V_{CC+}	Supply voltages (see Note 1)	8 V
V_{CC-}		-8 V
Input voltage (see Note 1)		6 V
Output sink current (any one output)		30 mA
θ_{JA}	Package thermal impedance (see Notes 2 and 3)	83°C/W
Lead temperature 1,6 mm (1/16 inch) from case for 10 seconds		260°C
T_{stg}	Storage temperature range (see Note 4)	-65°C to 150°C

† Stresses beyond those listed under “absolute maximum ratings” may cause permanent damage to the device. These are stress ratings only, and functional operation of the device at these or any other conditions beyond those indicated under “recommended operating conditions” is not implied. Exposure to absolute-maximum-rated conditions for extended periods may affect device reliability.

- NOTES:
1. All voltages, except differential out voltages, are with respect to network ground terminal.
 2. Maximum power dissipation is a function of $T_J(\text{max})$, θ_{JA} , and T_A . The maximum allowable power dissipation at any allowable ambient temperature is $P_D = (T_J(\text{max}) - T_A)/\theta_{JA}$. Operating at the absolute maximum T_J of 150°C can affect reliability.
 3. The package thermal impedance is calculated in accordance with JESD 51-7.
 4. Long-term high-temperature storage and/or extended use at maximum recommended operating conditions may result in a reduction of overall device life. See http://www.ti.com/ep_quality for additional information on enhanced plastic packaging.

RECOMMENDED OPERATING CONDITIONS

	MIN	MAX	UNIT
Peak-to-peak input voltage for each 30-dB stage	0.01	1	V
Operating free-air temperature, T_A	-55	125	°C

ELECTRICAL CHARACTERISTICS, $V_{CC\pm} = \pm 6\text{ V}$, $T_A = 25^\circ\text{C}$

PARAMETER	TEST FIGURE	MIN	TYP	MAX	UNIT
Differential output offset voltage	1		± 25	± 70	mV
Quiescent output voltage	2	5.45	5.6	5.85	V
DC scale factor (differential output), each 3-dB stage, -35 dBV to -5 dBV	3	7	8	11	mV/dB
AC scale factor (differential output)			8		mV/dB
DC error at -20 dBV (midpoint of -35 dBV to -5 dBV range)	3		1	2.6	dB
Input impedance			500		Ω
Output impedance			200		Ω
Rise time, 10% to 90% points, $C_L = 24\text{ pF}$	4		20	35	ns
Supply current from V_{CC+}	2	14.5	18.5	23	mA
Supply current from V_{CC-}	2	-6	-8.5	-10.5	mA
Power dissipation	2	123	162	201	mW

TL441-EP LOGARITHMIC AMPLIFIER

SGLS268 – OCTOBER 2004

ELECTRICAL CHARACTERISTICS OVER OPERATING FREE-AIR TEMPERATURE RANGE, $V_{CC\pm} = \pm 6\text{ V}$ (unless otherwise noted)

PARAMETER	TEST FIGURE	MIN	MAX	UNIT
Differential output offset voltage	1	± 125		mV
Quiescent output voltage	2	5.3	5.85	V
DC scale factor (differential output) each 30-dB stage, -35 dBV to -5 dBV	3	6	11	mV/dB
DC error at -20 dBV (midpoint of -35 dBV to -5 dBV range)	3	$T_A = -55^\circ\text{C}$		4
		$T_A = 125^\circ\text{C}$		3
Supply current from V_{CC+}	2	10	31	mA
Supply current from V_{CC-}	2	-4.5	-15	mA
Power dissipation	2	87	276	mW

PARAMETER MEASUREMENT INFORMATION

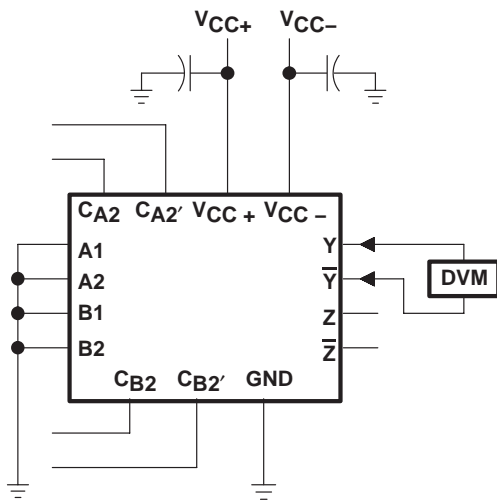

Figure 1

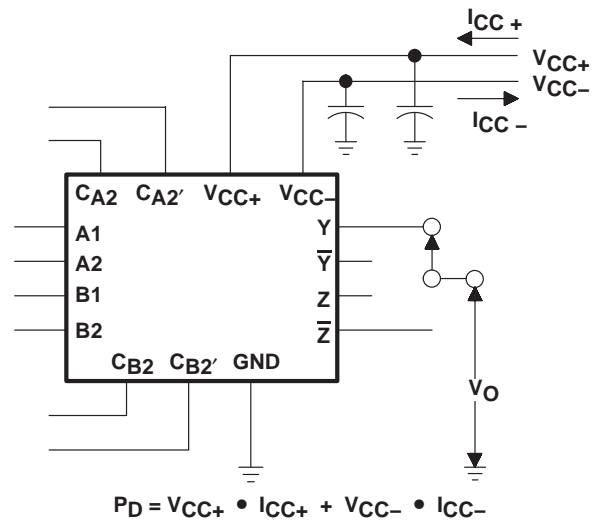

Figure 2

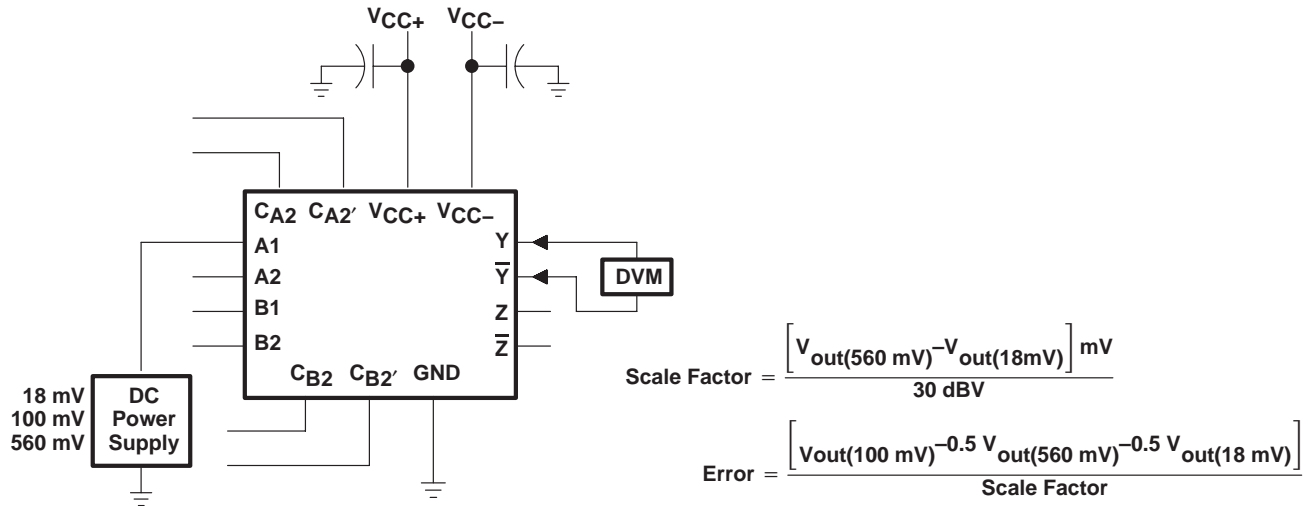
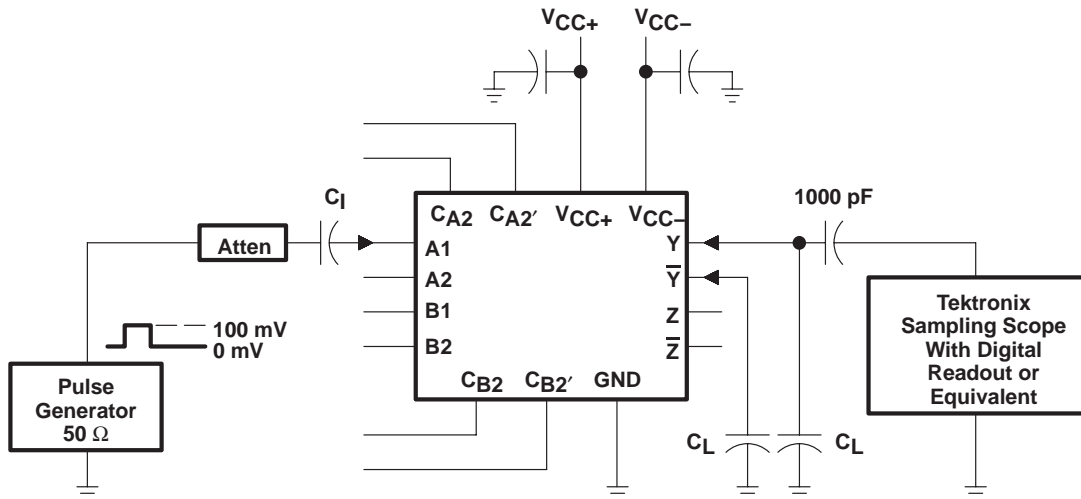

Figure 3



- NOTES: A. The input pulse has the following characteristics: $t_w = 200 \text{ ns}$, $t_r \leq 2 \text{ ns}$, $t_f \leq 2 \text{ ns}$, $\text{PRR} \leq 10 \text{ MHz}$.
 B. Capacitor C_1 consists of three capacitors in parallel: $1 \mu\text{F}$, $0.1 \mu\text{F}$, and $0.01 \mu\text{F}$.
 C. C_L includes probe and jig capacitance.

Figure 4

TYPICAL CHARACTERISTICS

DIFFERENTIAL OUTPUT OFFSET VOLTAGE
vs
FREE-AIR TEMPERATURE

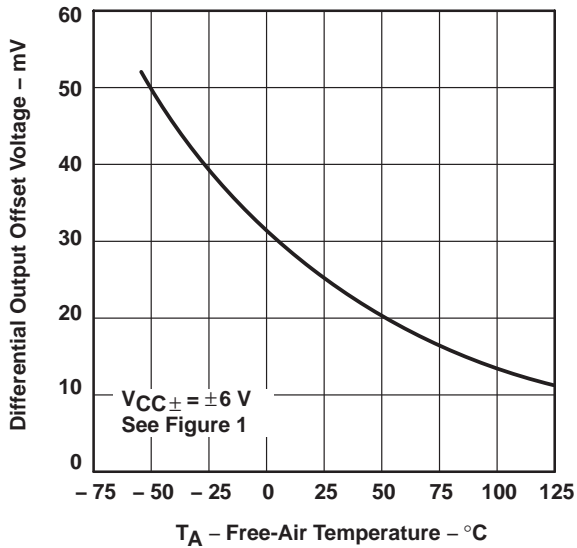

Figure 5

QUIESCENT OUTPUT VOLTAGE
vs
FREE-AIR TEMPERATURE

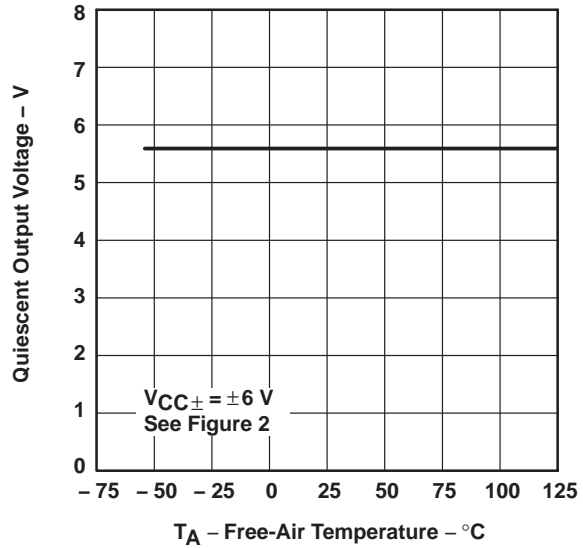

Figure 6

DC SCALE FACTOR
vs
FREE-AIR TEMPERATURE

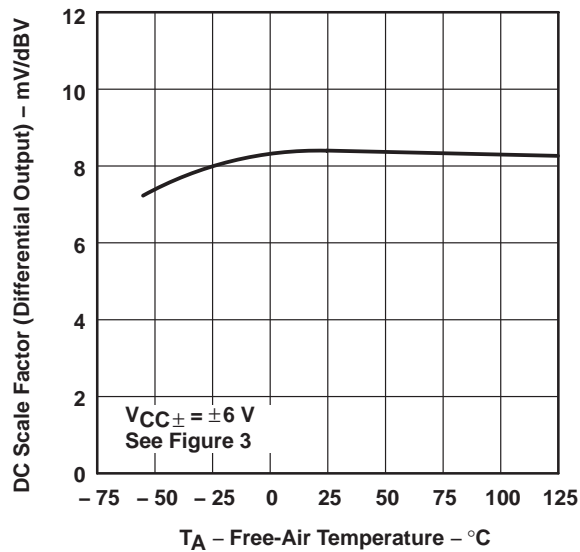

Figure 7

DC ERROR
vs
FREE-AIR TEMPERATURE

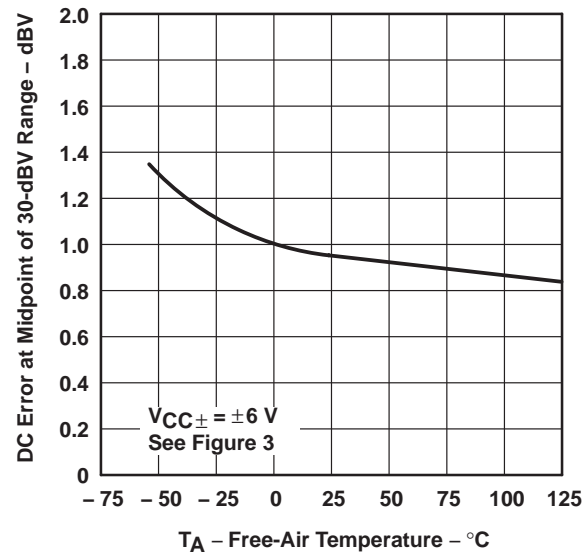

Figure 8

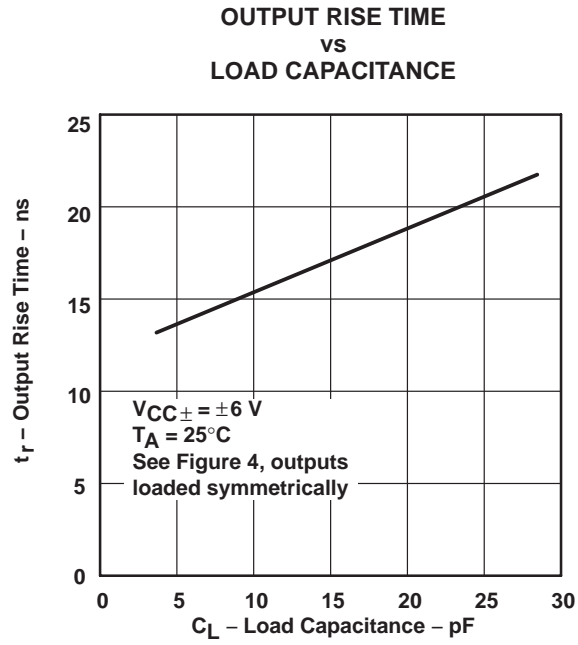

Figure 9

TL441-EP LOGARITHMIC AMPLIFIER

SGLS268 – OCTOBER 2004

APPLICATION INFORMATION

Although designed for high-performance applications such as infrared detection, this device has a wide range of applications in data compression and analog computation.

Basic Logarithmic Function

The basic logarithmic response is derived from the exponential current-voltage relationship of collector current and base-emitter voltage. This relationship is given in the equation:

$$m \cdot V_{BE} = \ln [(I_C + I_{CES})/I_{CES}]$$

where:

I_C = collector current

I_{CES} = collector current at $V_{BE} = 0$

m = q/kT (in V^{-1})

V_{BE} = base-emitter voltage

The differential input amplifier allows dual-polarity inputs, is self-compensating for temperature variations, and is relatively insensitive to common-mode noise.

Functional Block Diagram

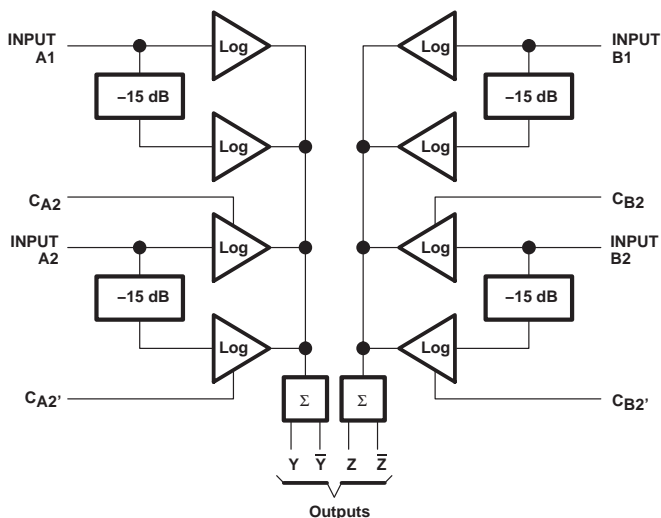

Figure 10

Logarithmic Sections

As can be seen from the schematic, there are eight differential pairs. Each pair is a 15-dB log subsection, and each input feeds two pairs, for a range of 30-dB per stage.

Four compensation points are available to allow slight variations in the gain (slope) of the two individual 15-dB stages of input A2 and B2. By slightly changing the voltage on any of the compensation pins from their quiescent values, the gain of that particular 15-dB stage can be adjusted to match the other 15-dB stage in the pair. The compensation pins also can be used to match the transfer characteristics of input A2 to A1 or B2 to B1.

The log stages in each half of the circuit are summed by directly connecting their collectors together and summing through a common-base output stage. The two sets of output collectors are used to give two log outputs, Y and \bar{Y} (or Z and \bar{Z}), which are equal in amplitude, but opposite in polarity. This increases the versatility of the device.

By proper choice of external connections, linear amplification, and linear attenuation many different applications requiring logarithmic signal processing are possible.

Input Levels

The recommended input voltage range of any one stage is given as 0.01 V to 1 V. Input levels in excess of 1 V may result in a distorted output. When several log sections are summed together, the distorted area of one section overlaps with the next section and the resulting distortion is insignificant. However, there is a limit to the amount of overdrive that can be applied. As the input drive reaches ± 3.5 V, saturation occurs, clamping the collector-summing line and severely distorting the output. Therefore, the signal to any input must be limited to approximately ± 3 V to ensure a clean output.

Output Levels

Differential-output-voltage levels are low, generally less than 0.6 V. As demonstrated in Figure 11, the output swing and the slope of the output response can be adjusted by varying the gain by means of the slope control. The coordinate origin also can be adjusted by positioning the offset of the output buffer.

Circuits

Figure 11 through Figure 18 show typical circuits using this logarithmic amplifier. Operational amplifiers not otherwise designated are TLC271. For operation at higher frequencies, the TL592 is recommended instead of the TLC271.

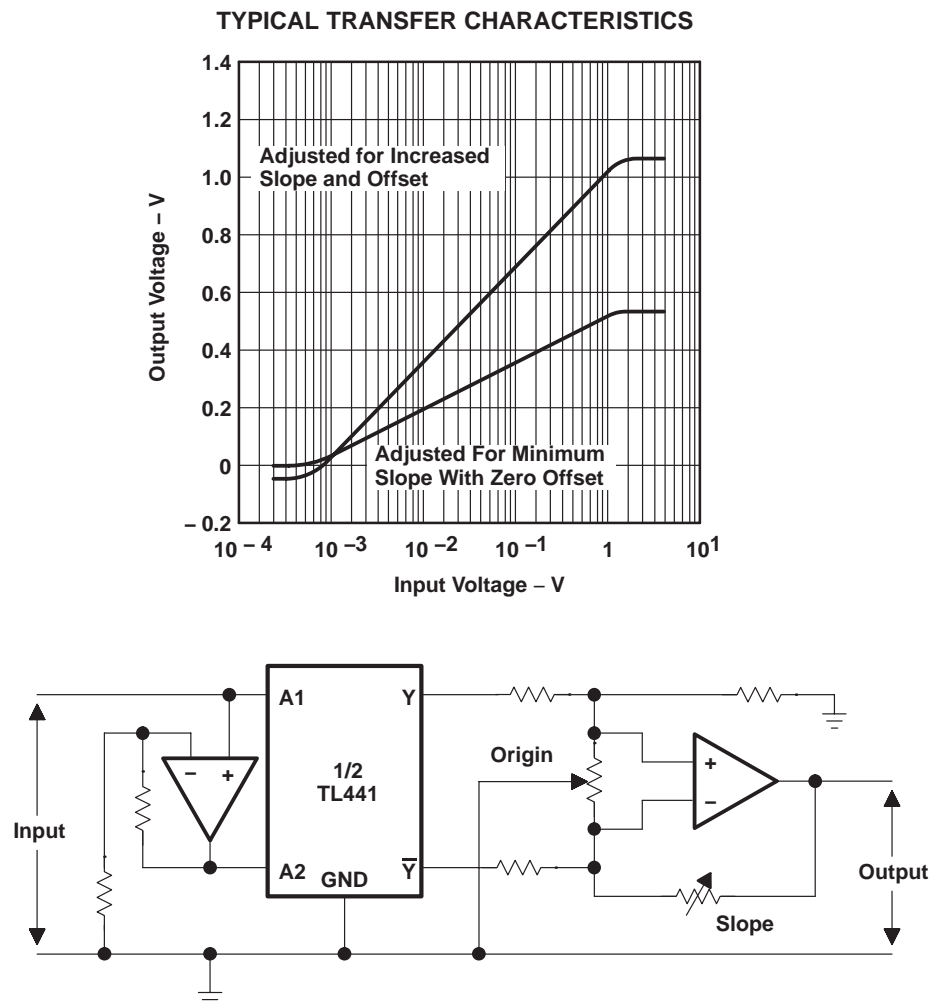

Figure 11. Output Slope and Origin Adjustment

TL441-EP LOGARITHMIC AMPLIFIER

SGLS268 – OCTOBER 2004

TRANSFER CHARACTERISTICS of TWO
TYPICAL INPUT STAGES

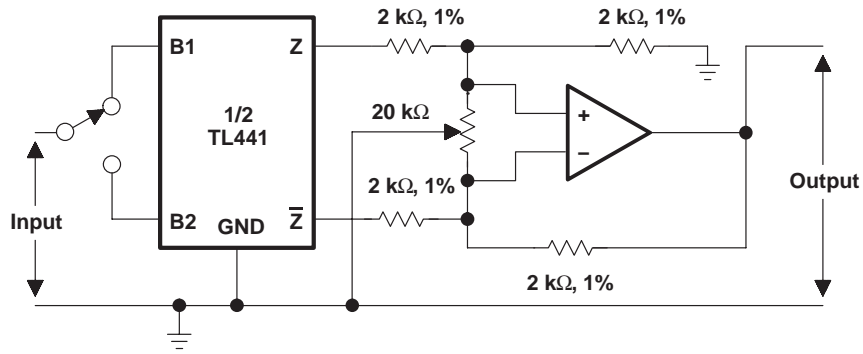
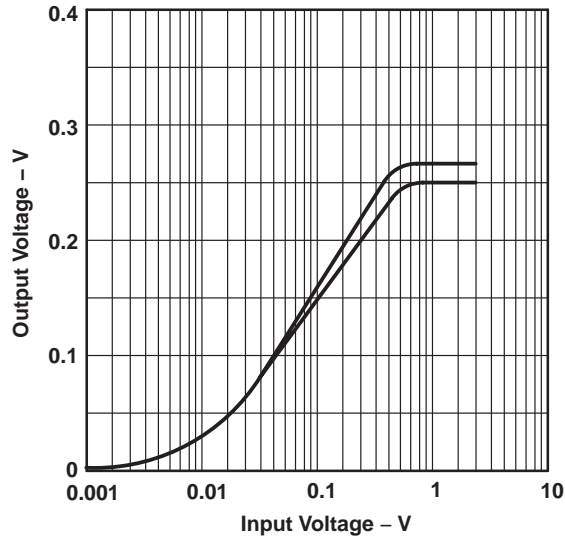

Figure 12. Utilization of Separate Stages

TRANSFER CHARACTERISTICS
WITH BOTH SIDES PARALLELED

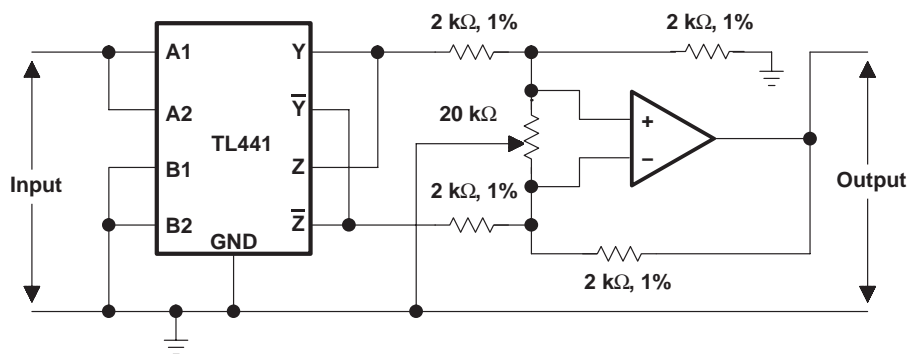
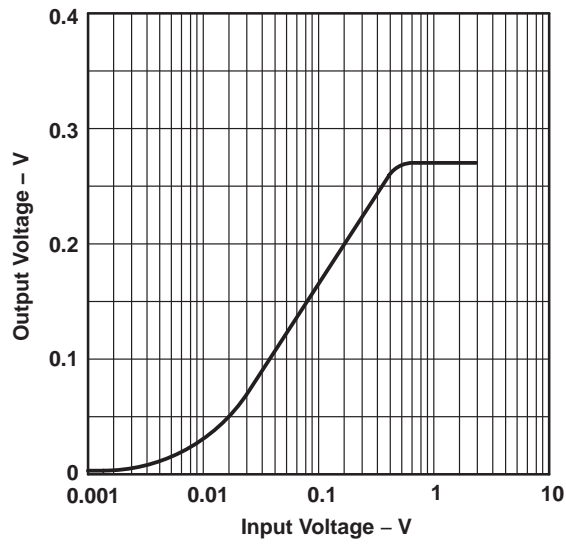
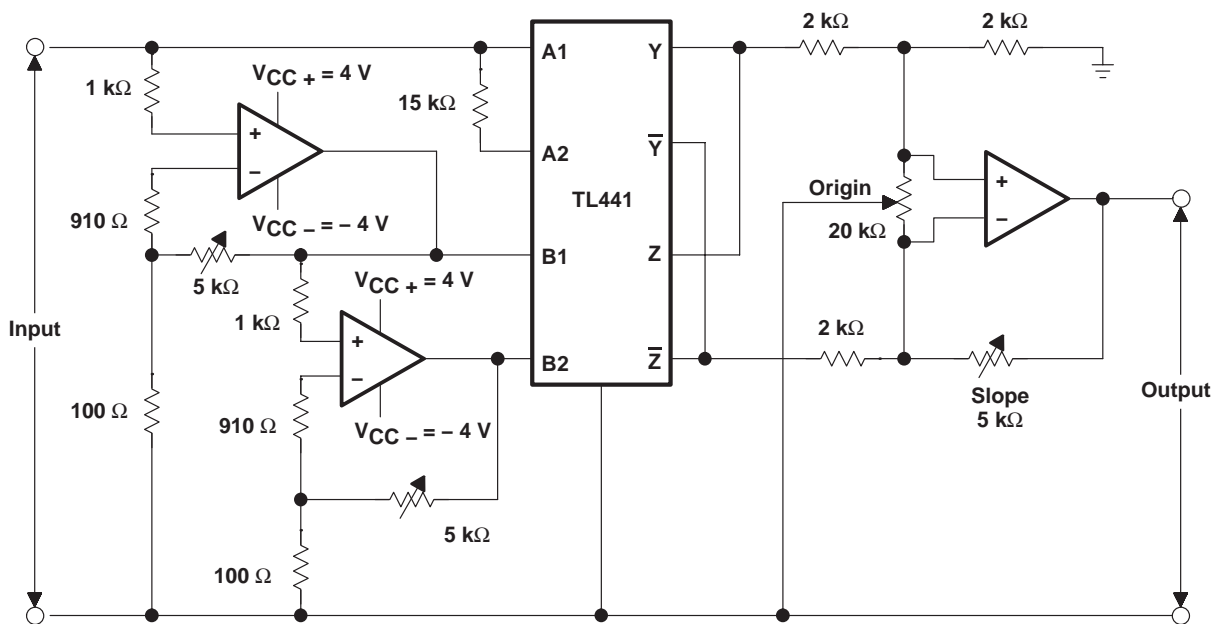
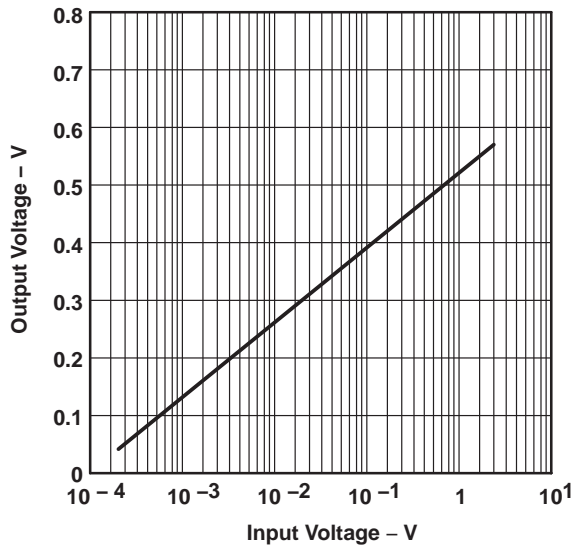

Figure 13. Utilization of Paralleled Inputs

TL441-EP LOGARITHMIC AMPLIFIER

SGLS268 – OCTOBER 2004

TRANSFER CHARACTERISTICS



NOTES: A. Inputs are limited by reducing the supply voltages for the input amplifiers to ± 4 V.
 B. The gains of the input amplifiers are adjusted to achieve smooth transitions.

Figure 14. Logarithmic Amplifier With Input Voltage Range Greater Than 80 dB

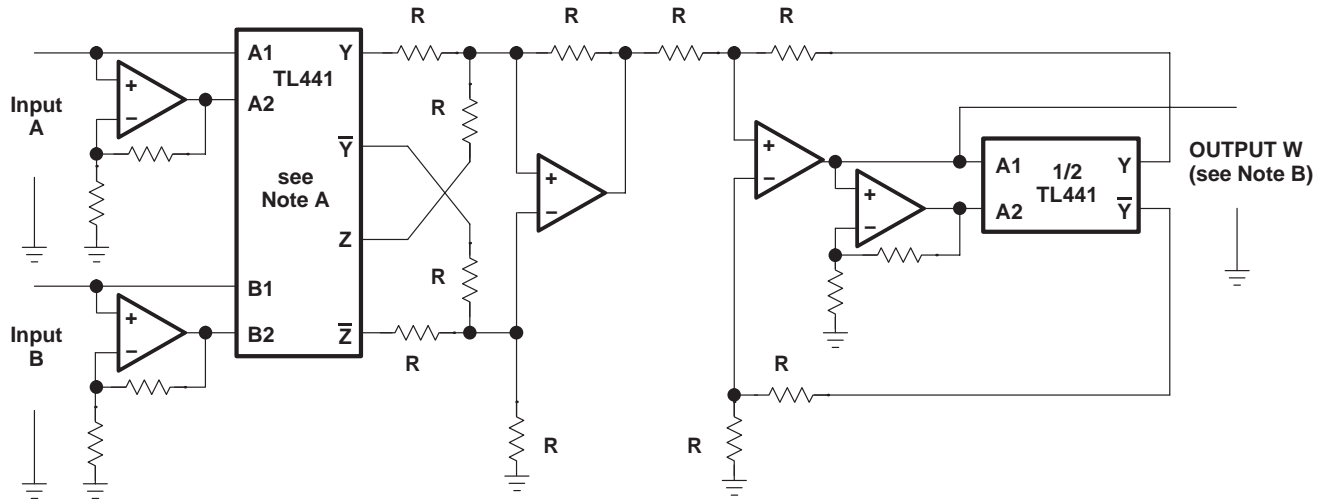

- NOTES: A. Connections shown are for multiplication. For division, Z and \bar{Z} connections are reversed.
 B. Output W may need to be amplified to give actual product or quotient of A and B.
 C. R designates resistors of equal value, typically 2 k Ω to 10 k Ω .

Multiplication: $W = A \cdot B \Rightarrow \log W = \log A + \log B$, or $W = a(\log_a A + \log_a B)$

Division: $W = A/B \Rightarrow \log W = \log A - \log B$, or $W = a(\log_a A - \log_a B)$

Figure 15. Multiplication or Division

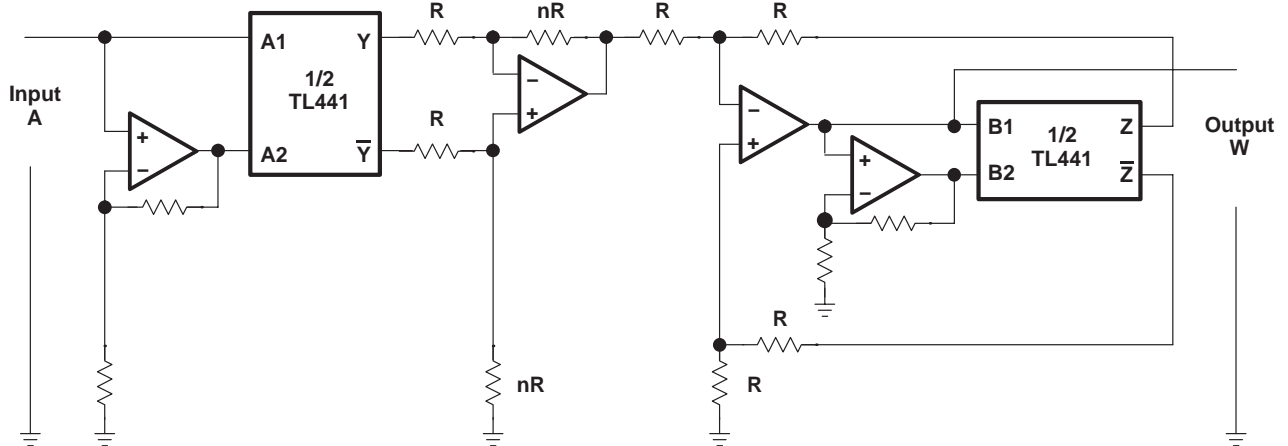

NOTE: R designates resistors of equal value, typically 2 k Ω to 10 k Ω . The power to which the input variable is raised is fixed by setting nR.
 Output W may need to be amplified to give the correct value.

Exponential: $W = A^n \Rightarrow \log W = n \log A$, or $W = a(n \log_a A)$

Figure 16. Raising a Variable to a Fixed Power

TL441-EP LOGARITHMIC AMPLIFIER

SGLS268 – OCTOBER 2004

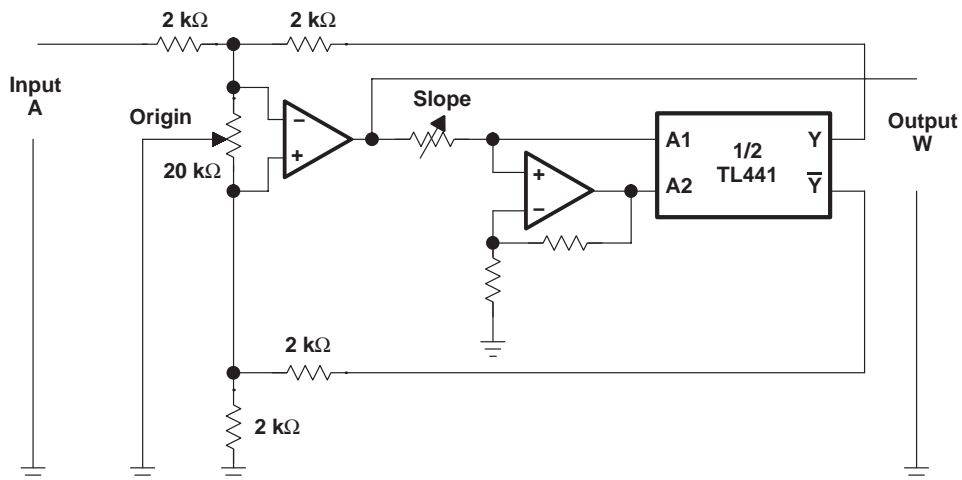

NOTE: Adjust the slope to correspond to the base "a". Exponential to any base: $W = a$.

Figure 17. Raising a Fixed Number to a Variable Power

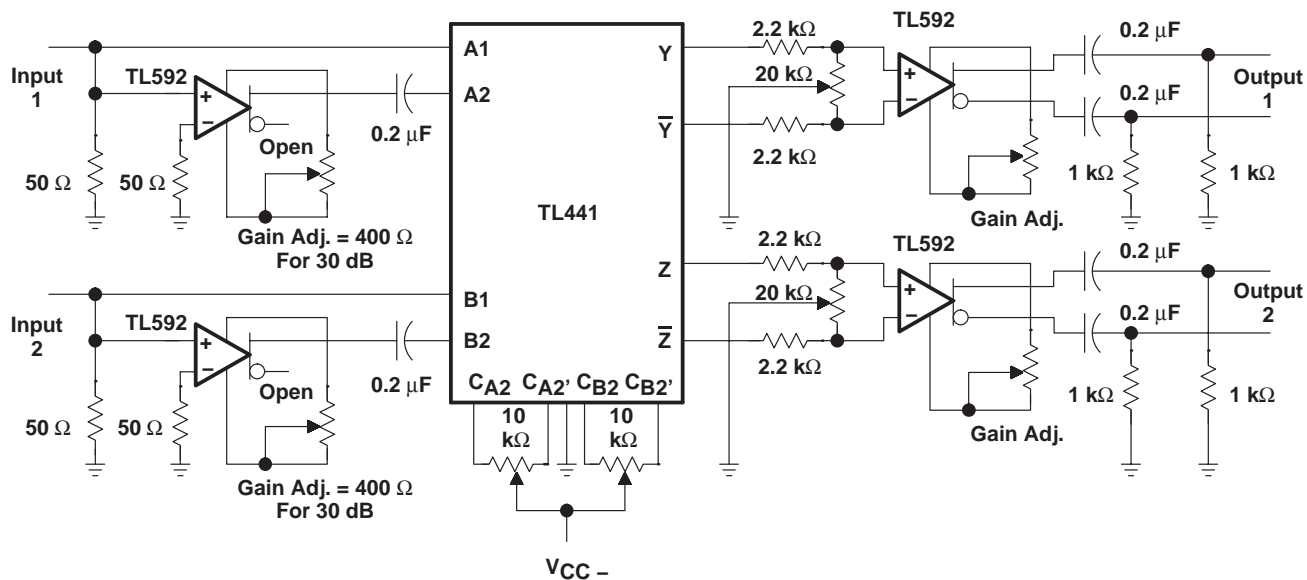

Figure 18. Dual-Channel RF Logarithmic Amplifier With 50-dB Input Range Per Channel at 10 MHz

MECHANICAL DATA

NS (R-PDSO-G**)

PLASTIC SMALL-OUTLINE PACKAGE

14-PINS SHOWN



- NOTES:
- A. All linear dimensions are in millimeters.
 - B. This drawing is subject to change without notice.
 - C. Body dimensions do not include mold flash or protrusion, not to exceed 0,15.

IMPORTANT NOTICE

Texas Instruments Incorporated and its subsidiaries (TI) reserve the right to make corrections, modifications, enhancements, improvements, and other changes to its products and services at any time and to discontinue any product or service without notice. Customers should obtain the latest relevant information before placing orders and should verify that such information is current and complete. All products are sold subject to TI's terms and conditions of sale supplied at the time of order acknowledgment.

TI warrants performance of its hardware products to the specifications applicable at the time of sale in accordance with TI's standard warranty. Testing and other quality control techniques are used to the extent TI deems necessary to support this warranty. Except where mandated by government requirements, testing of all parameters of each product is not necessarily performed.

TI assumes no liability for applications assistance or customer product design. Customers are responsible for their products and applications using TI components. To minimize the risks associated with customer products and applications, customers should provide adequate design and operating safeguards.

TI does not warrant or represent that any license, either express or implied, is granted under any TI patent right, copyright, mask work right, or other TI intellectual property right relating to any combination, machine, or process in which TI products or services are used. Information published by TI regarding third-party products or services does not constitute a license from TI to use such products or services or a warranty or endorsement thereof. Use of such information may require a license from a third party under the patents or other intellectual property of the third party, or a license from TI under the patents or other intellectual property of TI.

Reproduction of information in TI data books or data sheets is permissible only if reproduction is without alteration and is accompanied by all associated warranties, conditions, limitations, and notices. Reproduction of this information with alteration is an unfair and deceptive business practice. TI is not responsible or liable for such altered documentation.

Resale of TI products or services with statements different from or beyond the parameters stated by TI for that product or service voids all express and any implied warranties for the associated TI product or service and is an unfair and deceptive business practice. TI is not responsible or liable for any such statements.

Following are URLs where you can obtain information on other Texas Instruments products and application solutions:

Products		Applications	
Amplifiers	amplifier.ti.com	Audio	www.ti.com/audio
Data Converters	dataconverter.ti.com	Automotive	www.ti.com/automotive
DSP	dsp.ti.com	Broadband	www.ti.com/broadband
Interface	interface.ti.com	Digital Control	www.ti.com/digitalcontrol
Logic	logic.ti.com	Military	www.ti.com/military
Power Mgmt	power.ti.com	Optical Networking	www.ti.com/opticalnetwork
Microcontrollers	microcontroller.ti.com	Security	www.ti.com/security
		Telephony	www.ti.com/telephony
		Video & Imaging	www.ti.com/video
		Wireless	www.ti.com/wireless

Mailing Address: Texas Instruments
Post Office Box 655303 Dallas, Texas 75265