

FEATURES

- Complete PWM Power-Control Circuitry
- Uncommitted Outputs for 200-mA Sink or Source Current
- Output Control Selects Single-Ended or Push-Pull Operation
- Internal Circuitry Prohibits Double Pulse at Either Output
- Variable Dead Time Provides Control Over Total Range
- Internal Regulator Provides a Stable 5-V Reference Supply With 5% Tolerance
- Circuit Architecture Allows Easy Synchronization

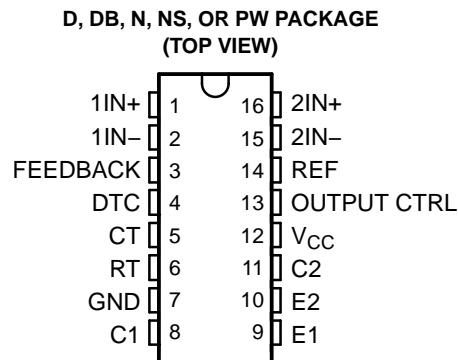

DESCRIPTION

The TL494 incorporates all the functions required in the construction of a pulse-width-modulation (PWM) control circuit on a single chip. Designed primarily for power-supply control, this device offers the flexibility to tailor the power-supply control circuitry to a specific application.

The TL494 contains two error amplifiers, an on-chip adjustable oscillator, a dead-time control (DTC) comparator, a pulse-steering control flip-flop, a 5-V, 5%-precision regulator, and output-control circuits.

The error amplifiers exhibit a common-mode voltage range from -0.3 V to $V_{CC} - 2\text{ V}$. The dead-time control comparator has a fixed offset that provides approximately 5% dead time. The on-chip oscillator can be bypassed by terminating RT to the reference output and providing a sawtooth input to CT, or it can drive the common circuits in synchronous multiple-rail power supplies.

The uncommitted output transistors provide either common-emitter or emitter-follower output capability. The TL494 provides for push-pull or single-ended output operation, which can be selected through the output-control function. The architecture of this device prohibits the possibility of either output being pulsed twice during push-pull operation.

The TL494C is characterized for operation from 0°C to 70°C . The TL494I is characterized for operation from -40°C to 85°C .

AVAILABLE OPTIONS

| T_A | PACKAGED DEVICES ⁽¹⁾ | | | | |
|---|---------------------------------|-----------------|--------------------|---------------------------|--------------------------------|
| | SMALL OUTLINE (D) | PLASTIC DIP (N) | SMALL OUTLINE (NS) | SHRINK SMALL OUTLINE (DB) | THIN SHRINK SMALL OUTLINE (PW) |
| 0°C to 70°C | TL494CD | TL494CN | TL494CNS | TL494CDB | TL494CPW |
| -40°C to 85°C | TL494ID | TL494IN | — | — | — |

(1) The D, DB, NS, and PW packages are available taped and reeled. Add the suffix R to device type (e.g., TL494CDR).



Please be aware that an important notice concerning availability, standard warranty, and use in critical applications of Texas Instruments semiconductor products and disclaimers thereto appears at the end of this data sheet.

FUNCTION TABLE

| INPUT TO OUTPUT CTRL | OUTPUT FUNCTION |
|------------------------|---------------------------------|
| $V_I = \text{GND}$ | Single-ended or parallel output |
| $V_I = V_{\text{ref}}$ | Normal push-pull operation |

FUNCTIONAL BLOCK DIAGRAM

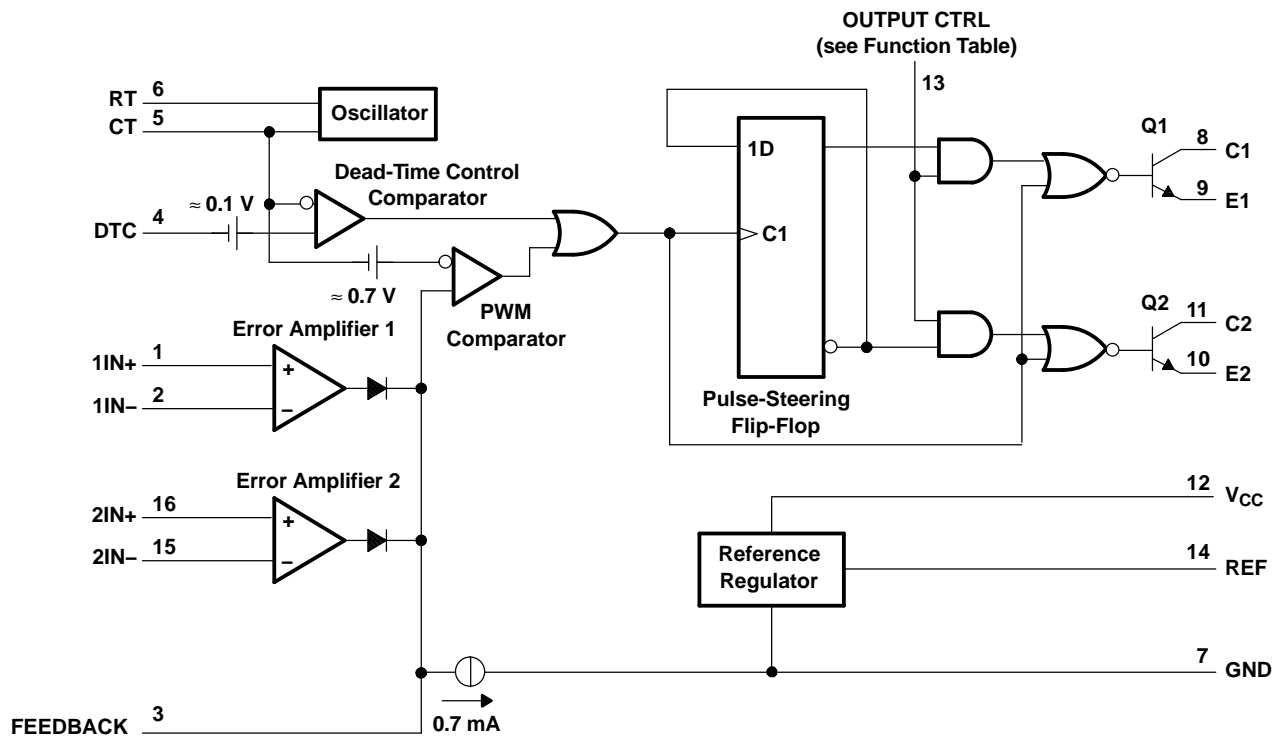

Absolute Maximum Ratings⁽¹⁾

over operating free-air temperature range (unless otherwise noted)

| | | MIN | MAX | UNIT |
|--|---|------------|----------------|------|
| V_{CC} | Supply voltage ⁽²⁾ | | 41 | V |
| V_I | Amplifier input voltage | | $V_{CC} + 0.3$ | V |
| V_O | Collector output voltage | | 41 | V |
| I_O | Collector output current | | 250 | mA |
| θ_{JA} | Package thermal impedance ⁽³⁾⁽⁴⁾ | D package | 73 | °C/W |
| | | DB package | 82 | |
| | | N package | 67 | |
| | | NS package | 64 | |
| | | PW package | 108 | |
| Lead temperature 1,6 mm (1/16 inch) from case for 10 seconds | | | 260 | °C |
| T_{stg} | Storage temperature range | –65 | 150 | °C |

- (1) Stresses beyond those listed under "absolute maximum ratings" may cause permanent damage to the device. These are stress ratings only, and functional operation of the device at these or any other conditions beyond those indicated under "recommended operating conditions" is not implied. Exposure to absolute-maximum-rated conditions for extended periods may affect device reliability.
- (2) All voltages are with respect to the network ground terminal.
- (3) Maximum power dissipation is a function of $T_J(\text{max})$, θ_{JA} , and T_A . The maximum allowable power dissipation at any allowable ambient temperature is $P_D = (T_J(\text{max}) - T_A)/\theta_{JA}$. Operating at the absolute maximum T_J of 150°C can affect reliability.
- (4) The package thermal impedance is calculated in accordance with JEDEC 51-7.

Recommended Operating Conditions

| | | MIN | MAX | UNIT | |
|-----------|--|--------|--------------|------------|----|
| V_{CC} | Supply voltage | 7 | 40 | V | |
| V_I | Amplifier input voltage | –0.3 | $V_{CC} - 2$ | V | |
| V_O | Collector output voltage | | 40 | V | |
| | Collector output current (each transistor) | | 200 | mA | |
| | Current into feedback terminal | | 0.3 | mA | |
| f_{OSC} | Oscillator frequency | 1 | 300 | kHz | |
| C_T | Timing capacitor | 0.47 | 10000 | nF | |
| R_T | Timing resistor | 1.8 | 500 | k Ω | |
| T_A | Operating free-air temperature | TL494C | 0 | 70 | °C |
| | | TL494I | –40 | 85 | |

Electrical Characteristics

over recommended operating free-air temperature range, $V_{CC} = 15\text{ V}$, $f = 10\text{ kHz}$ (unless otherwise noted)

Reference Section

| PARAMETER | TEST CONDITIONS ⁽¹⁾ | TL494C, TL494I | | | UNIT |
|---|--------------------------------------|----------------|--------------------|------|------|
| | | MIN | TYP ⁽²⁾ | MAX | |
| Output voltage (REF) | $I_O = 1\text{ mA}$ | 4.75 | 5 | 5.25 | V |
| Input regulation | $V_{CC} = 7\text{ V to }40\text{ V}$ | | 2 | 25 | mV |
| Output regulation | $I_O = 1\text{ mA to }10\text{ mA}$ | | 1 | 15 | mV |
| Output voltage change with temperature | $\Delta T_A = \text{MIN to MAX}$ | | 2 | 10 | mV/V |
| Short-circuit output current ⁽³⁾ | REF = 0 V | | 25 | | mA |

- (1) For conditions shown as MIN or MAX, use the appropriate value specified under recommended operating conditions.
(2) All typical values, except for parameter changes with temperature, are at $T_A = 25^\circ\text{C}$.
(3) Duration of short circuit should not exceed one second.

Oscillator Section

$C_T = 0.01\text{ }\mu\text{F}$, $R_T = 12\text{ k}\Omega$ (see Figure 1)

| PARAMETER | TEST CONDITIONS ⁽¹⁾ | TL494C, TL494I | | | UNIT |
|--|---|----------------|--------------------|-----|--------|
| | | MIN | TYP ⁽²⁾ | MAX | |
| Frequency | | | 10 | | kHz |
| Standard deviation of frequency ⁽³⁾ | All values of V_{CC} , C_T , R_T , and T_A constant | | 100 | | Hz/kHz |
| Frequency change with voltage | $V_{CC} = 7\text{ V to }40\text{ V}$, $T_A = 25^\circ\text{C}$ | | 1 | | Hz/kHz |
| Frequency change with temperature ⁽⁴⁾ | $\Delta T_A = \text{MIN to MAX}$ | | | 10 | Hz/kHz |

- (1) For conditions shown as MIN or MAX, use the appropriate value specified under recommended operating conditions.
(2) All typical values, except for parameter changes with temperature, are at $T_A = 25^\circ\text{C}$.
(3) Standard deviation is a measure of the statistical distribution about the mean as derived from the formula:

$$\sigma = \sqrt{\frac{\sum_{n=1}^N (x_n - \bar{X})^2}{N - 1}}$$

- (4) Temperature coefficient of timing capacitor and timing resistor are not taken into account.

Error-Amplifier Section

See Figure 2

| PARAMETER | TEST CONDITIONS | TL494C, TL494I | | | UNIT |
|----------------------------------|---|----------------|----------------------|-----|---------------|
| | | MIN | TYP ⁽¹⁾ | MAX | |
| Input offset voltage | $V_O (\text{FEEDBACK}) = 2.5\text{ V}$ | | 2 | 10 | mV |
| Input offset current | $V_O (\text{FEEDBACK}) = 2.5\text{ V}$ | | 25 | 250 | nA |
| Input bias current | $V_O (\text{FEEDBACK}) = 2.5\text{ V}$ | | 0.2 | 1 | μA |
| Common-mode input voltage range | $V_{CC} = 7\text{ V to }40\text{ V}$ | | -0.3 to $V_{CC} - 2$ | | V |
| Open-loop voltage amplification | $\Delta V_O = 3\text{ V}$, $V_O = 0.5\text{ V to }3.5\text{ V}$, $R_L = 2\text{ k}\Omega$ | | 70 | 95 | dB |
| Unity-gain bandwidth | $V_O = 0.5\text{ V to }3.5\text{ V}$, $R_L = 2\text{ k}\Omega$ | | 800 | | kHz |
| Common-mode rejection ratio | $\Delta V_O = 40\text{ V}$, $T_A = 25^\circ\text{C}$ | | 65 | 80 | dB |
| Output sink current (FEEDBACK) | $V_{ID} = -15\text{ mV to }-5\text{ V}$, $V (\text{FEEDBACK}) = 0.7\text{ V}$ | | 0.3 | 0.7 | mA |
| Output source current (FEEDBACK) | $V_{ID} = 15\text{ mV to }5\text{ V}$, $V (\text{FEEDBACK}) = 3.5\text{ V}$ | | -2 | | mA |

- (1) All typical values, except for parameter changes with temperature, are at $T_A = 25^\circ\text{C}$.

Electrical Characteristics

over recommended operating free-air temperature range, $V_{CC} = 15\text{ V}$, $f = 10\text{ kHz}$ (unless otherwise noted)

Output Section

| PARAMETER | | TEST CONDITIONS | MIN | TYP ⁽¹⁾ | MAX | UNIT |
|--------------------------------------|------------------|---|-----|--------------------|------|---------------|
| Collector off-state current | | $V_{CE} = 40\text{ V}$, $V_{CC} = 40\text{ V}$ | | 2 | 100 | μA |
| Emitter off-state current | | $V_{CC} = V_C = 40\text{ V}$, $V_E = 0$ | | | -100 | μA |
| Collector-emitter saturation voltage | Common emitter | $V_E = 0$, $I_C = 200\text{ mA}$ | | 1.1 | 1.3 | V |
| | Emitter follower | $V_{O(C1\text{ or }C2)} = 15\text{ V}$, $I_E = -200\text{ mA}$ | | 1.5 | 2.5 | |
| Output control input current | | $V_I = V_{ref}$ | | | 3.5 | mA |

(1) All typical values, except for temperature coefficient, are at $T_A = 25^\circ\text{C}$.

Dead-Time Control Section

See Figure 1

| PARAMETER | | TEST CONDITIONS | MIN | TYP ⁽¹⁾ | MAX | UNIT |
|--|--------------------|--|-----|--------------------|-----|---------------|
| Input bias current (DEAD-TIME CTRL) | | $V_I = 0$ to 5.25 V | | -2 | -10 | μA |
| Maximum duty cycle, each output | | V_I (DEAD-TIME CTRL) = 0, $C_T = 0.01\ \mu\text{F}$, $R_T = 12\text{ k}\Omega$ | | 45 | | % |
| Input threshold voltage (DEAD-TIME CTRL) | Zero duty cycle | | | 3 | 3.3 | V |
| | Maximum duty cycle | | 0 | | | |

(1) All typical values, except for temperature coefficient, are at $T_A = 25^\circ\text{C}$.

PWM Comparator Section

See Figure 1

| PARAMETER | | TEST CONDITIONS | MIN | TYP ⁽¹⁾ | MAX | UNIT |
|------------------------------------|--|---------------------------------|-----|--------------------|-----|------|
| Input threshold voltage (FEEDBACK) | | Zero duty cycle | | 4 | 4.5 | V |
| Input sink current (FEEDBACK) | | V (FEEDBACK) = 0.7 V | 0.3 | 0.7 | | mA |

(1) All typical values, except for temperature coefficient, are at $T_A = 25^\circ\text{C}$.

Total Device

| PARAMETER | | TEST CONDITIONS | MIN | TYP ⁽¹⁾ | MAX | UNIT |
|------------------------|--|--|-----|--------------------|-----|------|
| Standby supply current | $R_T = V_{ref}$, All other inputs and outputs open | $V_{CC} = 15\text{ V}$ | | 6 | 10 | mA |
| | | $V_{CC} = 40\text{ V}$ | | 9 | 15 | |
| Average supply current | | V_I (DEAD-TIME CTRL) = 2 V , See Figure 1 | | 7.5 | | mA |

(1) All typical values, except for temperature coefficient, are at $T_A = 25^\circ\text{C}$.

Switching Characteristics

$T_A = 25^\circ\text{C}$

| PARAMETER | | TEST CONDITIONS | MIN | TYP ⁽¹⁾ | MAX | UNIT |
|-----------|--|-----------------|-----|--------------------|-----|------|
| Rise time | Common-emitter configuration, See Figure 3 | | | 100 | 200 | ns |
| Fall time | | | | 25 | 100 | ns |
| Rise time | Emitter-follower configuration, See Figure 4 | | | 100 | 200 | ns |
| Fall time | | | | 40 | 100 | ns |

(1) All typical values, except for temperature coefficient, are at $T_A = 25^\circ\text{C}$.

PARAMETER MEASUREMENT INFORMATION

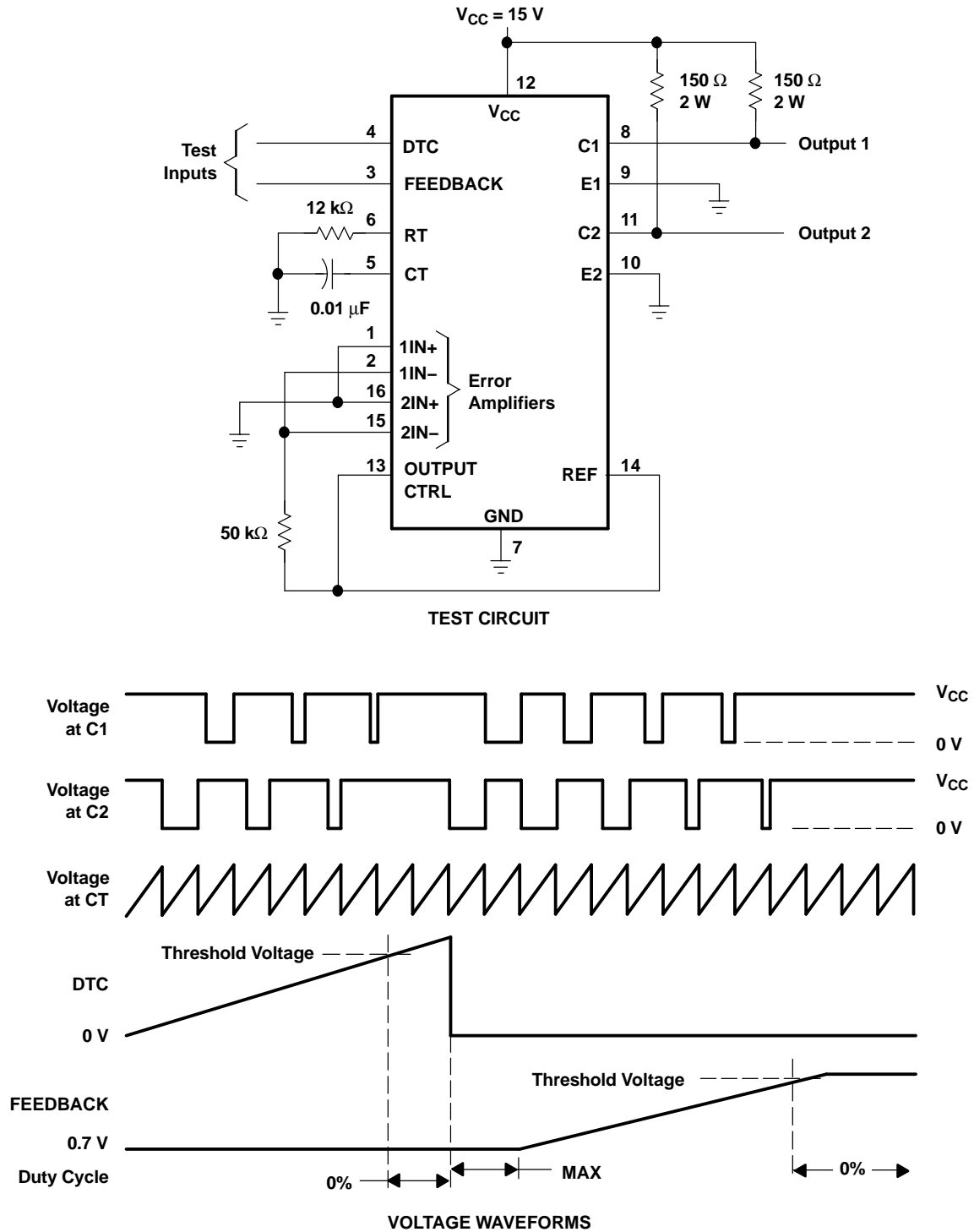

Figure 1. Operational Test Circuit and Waveforms

PARAMETER MEASUREMENT INFORMATION

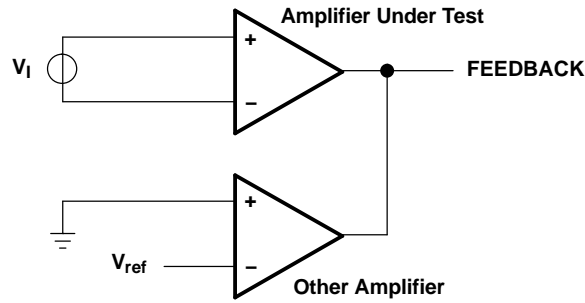
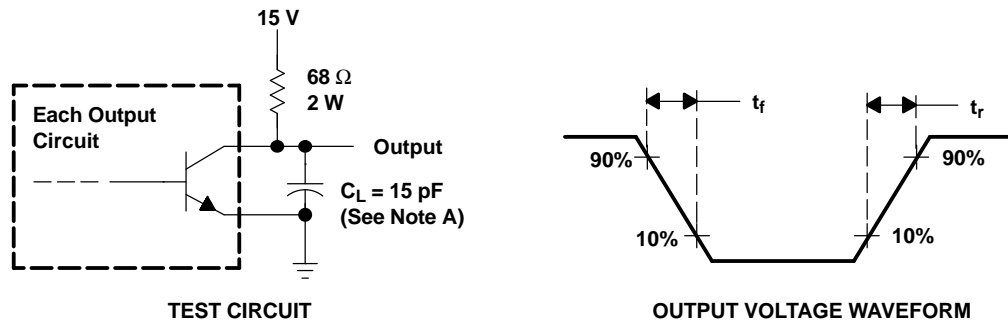
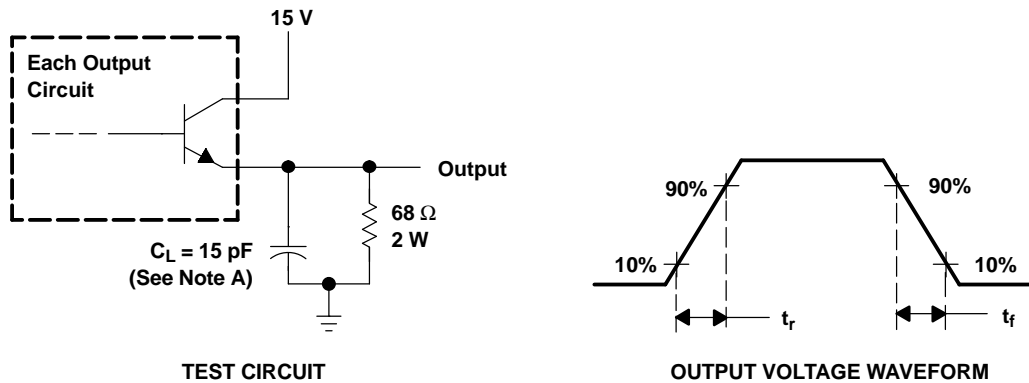

Figure 2. Amplifier Characteristics



NOTE A: C_L includes probe and jig capacitance.

Figure 3. Common-Emitter Configuration



NOTE A: C_L includes probe and jig capacitance.

Figure 4. Emitter-Follower Configuration

TYPICAL CHARACTERISTICS

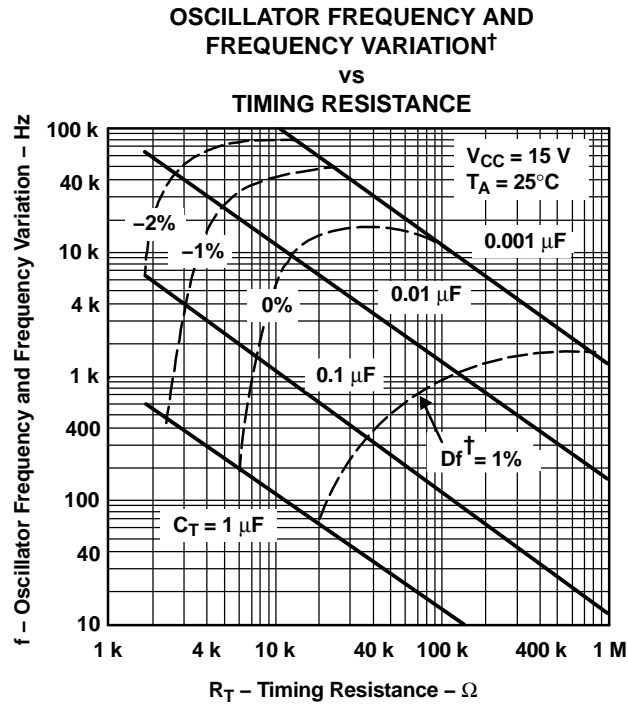

† Frequency variation (Δf) is the change in oscillator frequency that occurs over the full temperature range.

Figure 5.

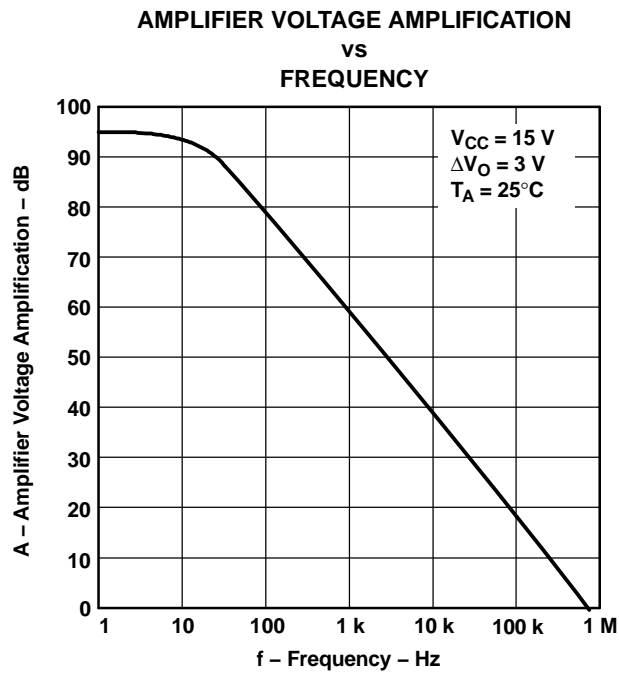

Figure 6.

PACKAGING INFORMATION

| Orderable Device | Status ⁽¹⁾ | Package Type | Package Drawing | Pins | Package Qty | Eco Plan ⁽²⁾ | Lead/Ball Finish | MSL Peak Temp ⁽³⁾ |
|------------------|-----------------------|--------------|-----------------|------|-------------|-------------------------|------------------|--|
| TL494CD | ACTIVE | SOIC | D | 16 | 40 | Pb-Free (RoHS) | CU NIPDAU | Level-2-260C-1 YEAR/ Level-1-235C-UNLIM |
| TL494CDBR | ACTIVE | SSOP | DB | 16 | 2000 | Pb-Free (RoHS) | CU NIPDAU | Level-2-260C-1 YEAR/ Level-1-235C-UNLIM |
| TL494CDR | ACTIVE | SOIC | D | 16 | 2500 | Pb-Free (RoHS) | CU NIPDAU | Level-2-260C-1 YEAR/ Level-1-235C-UNLIM |
| TL494CJ | OBSOLETE | CDIP | J | 16 | | None | Call TI | Call TI |
| TL494CN | ACTIVE | PDIP | N | 16 | 25 | Pb-Free (RoHS) | CU NIPDAU | Level-NC-NC-NC |
| TL494CNSR | ACTIVE | SO | NS | 16 | 2000 | Pb-Free (RoHS) | CU NIPDAU | Level-2-260C-1 YEAR/ Level-1-235C-UNLIM |
| TL494CPW | ACTIVE | TSSOP | PW | 16 | 90 | Pb-Free (RoHS) | CU NIPDAU | Level-1-250C-UNLIM |
| TL494CPWLE | OBSOLETE | TSSOP | PW | 16 | | None | Call TI | Call TI |
| TL494CPWR | ACTIVE | TSSOP | PW | 16 | 2000 | Pb-Free (RoHS) | CU NIPDAU | Level-1-250C-UNLIM |
| TL494ID | ACTIVE | SOIC | D | 16 | 40 | Pb-Free (RoHS) | CU NIPDAU | Level-2-260C-1 YEAR/ Level-1-235C-UNLIM |
| TL494IDR | ACTIVE | SOIC | D | 16 | 2500 | Pb-Free (RoHS) | CU NIPDAU | Level-2-260C-1 YEAR/ Level-1-235C-UNLIM |
| TL494IN | ACTIVE | PDIP | N | 16 | 25 | Pb-Free (RoHS) | CU NIPDAU | Level-NC-NC-NC |
| TL494MJ | OBSOLETE | CDIP | J | 16 | | None | Call TI | Call TI |
| TL494MJB | OBSOLETE | CDIP | J | 16 | | None | Call TI | Call TI |

⁽¹⁾ The marketing status values are defined as follows:

ACTIVE: Product device recommended for new designs.

LIFEBUY: TI has announced that the device will be discontinued, and a lifetime-buy period is in effect.

NRND: Not recommended for new designs. Device is in production to support existing customers, but TI does not recommend using this part in a new design.

PREVIEW: Device has been announced but is not in production. Samples may or may not be available.

OBSOLETE: TI has discontinued the production of the device.

⁽²⁾ Eco Plan - May not be currently available - please check <http://www.ti.com/productcontent> for the latest availability information and additional product content details.

None: Not yet available Lead (Pb-Free).

Pb-Free (RoHS): TI's terms "Lead-Free" or "Pb-Free" mean semiconductor products that are compatible with the current RoHS requirements for all 6 substances, including the requirement that lead not exceed 0.1% by weight in homogeneous materials. Where designed to be soldered at high temperatures, TI Pb-Free products are suitable for use in specified lead-free processes.

Green (RoHS & no Sb/Br): TI defines "Green" to mean "Pb-Free" and in addition, uses package materials that do not contain halogens, including bromine (Br) or antimony (Sb) above 0.1% of total product weight.

⁽³⁾ MSL, Peak Temp. -- The Moisture Sensitivity Level rating according to the JEDEC industry standard classifications, and peak solder temperature.

Important Information and Disclaimer: The information provided on this page represents TI's knowledge and belief as of the date that it is provided. TI bases its knowledge and belief on information provided by third parties, and makes no representation or warranty as to the accuracy of such information. Efforts are underway to better integrate information from third parties. TI has taken and continues to take reasonable steps to provide representative and accurate information but may not have conducted destructive testing or chemical analysis on incoming materials and chemicals. TI and TI suppliers consider certain information to be proprietary, and thus CAS numbers and other limited information may not be available for release.

In no event shall TI's liability arising out of such information exceed the total purchase price of the TI part(s) at issue in this document sold by TI

to Customer on an annual basis.

J (R-GDIP-T**)

14 LEADS SHOWN

CERAMIC DUAL IN-LINE PACKAGE



| DIM \ PINS ** | 14 | 16 | 18 | 20 |
|---------------|------------------------|------------------------|------------------------|------------------------|
| A | 0.300 (7,62) BSC | 0.300 (7,62) BSC | 0.300 (7,62) BSC | 0.300 (7,62) BSC |
| B MAX | 0.785 (19,94) | .840 (21,34) | 0.960 (24,38) | 1.060 (26,92) |
| B MIN | — | — | — | — |
| C MAX | 0.300 (7,62) | 0.300 (7,62) | 0.310 (7,87) | 0.300 (7,62) |
| C MIN | 0.245 (6,22) | 0.245 (6,22) | 0.220 (5,59) | 0.245 (6,22) |



4040083/F 03/03

- NOTES:
- All linear dimensions are in inches (millimeters).
 - This drawing is subject to change without notice.
 - This package is hermetically sealed with a ceramic lid using glass frit.
 - Index point is provided on cap for terminal identification only on press ceramic glass frit seal only.
 - Falls within MIL STD 1835 GDIP1-T14, GDIP1-T16, GDIP1-T18 and GDIP1-T20.

N (R-PDIP-T**)

PLASTIC DUAL-IN-LINE PACKAGE

16 PINS SHOWN



- NOTES:
- A. All linear dimensions are in inches (millimeters).
 - B. This drawing is subject to change without notice.
 - Falls within JEDEC MS-001, except 18 and 20 pin minimum body length (Dim A).
 - The 20 pin end lead shoulder width is a vendor option, either half or full width.

D (R-PDSO-G16)

PLASTIC SMALL-OUTLINE PACKAGE



- NOTES:
- A. All linear dimensions are in inches (millimeters).
 - B. This drawing is subject to change without notice.
 - C. Body dimensions do not include mold flash or protrusion not to exceed 0.006 (0,15).
 - D. Falls within JEDEC MS-012 variation AC.

MECHANICAL DATA

NS (R-PDSO-G**)

PLASTIC SMALL-OUTLINE PACKAGE

14-PINS SHOWN



- NOTES:
- A. All linear dimensions are in millimeters.
 - B. This drawing is subject to change without notice.
 - C. Body dimensions do not include mold flash or protrusion, not to exceed 0,15.

DB (R-PDSO-G**)

PLASTIC SMALL-OUTLINE

28 PINS SHOWN



- NOTES: A. All linear dimensions are in millimeters.
 B. This drawing is subject to change without notice.
 C. Body dimensions do not include mold flash or protrusion not to exceed 0,15.
 D. Falls within JEDEC MO-150

PW (R-PDSO-G**)

PLASTIC SMALL-OUTLINE PACKAGE

14 PINS SHOWN



4040064/F 01/97

- NOTES: A. All linear dimensions are in millimeters.
 B. This drawing is subject to change without notice.
 C. Body dimensions do not include mold flash or protrusion not to exceed 0,15.
 D. Falls within JEDEC MO-153

IMPORTANT NOTICE

Texas Instruments Incorporated and its subsidiaries (TI) reserve the right to make corrections, modifications, enhancements, improvements, and other changes to its products and services at any time and to discontinue any product or service without notice. Customers should obtain the latest relevant information before placing orders and should verify that such information is current and complete. All products are sold subject to TI's terms and conditions of sale supplied at the time of order acknowledgment.

TI warrants performance of its hardware products to the specifications applicable at the time of sale in accordance with TI's standard warranty. Testing and other quality control techniques are used to the extent TI deems necessary to support this warranty. Except where mandated by government requirements, testing of all parameters of each product is not necessarily performed.

TI assumes no liability for applications assistance or customer product design. Customers are responsible for their products and applications using TI components. To minimize the risks associated with customer products and applications, customers should provide adequate design and operating safeguards.

TI does not warrant or represent that any license, either express or implied, is granted under any TI patent right, copyright, mask work right, or other TI intellectual property right relating to any combination, machine, or process in which TI products or services are used. Information published by TI regarding third-party products or services does not constitute a license from TI to use such products or services or a warranty or endorsement thereof. Use of such information may require a license from a third party under the patents or other intellectual property of the third party, or a license from TI under the patents or other intellectual property of TI.

Reproduction of information in TI data books or data sheets is permissible only if reproduction is without alteration and is accompanied by all associated warranties, conditions, limitations, and notices. Reproduction of this information with alteration is an unfair and deceptive business practice. TI is not responsible or liable for such altered documentation.

Resale of TI products or services with statements different from or beyond the parameters stated by TI for that product or service voids all express and any implied warranties for the associated TI product or service and is an unfair and deceptive business practice. TI is not responsible or liable for any such statements.

Following are URLs where you can obtain information on other Texas Instruments products and application solutions:

| Products | | Applications | |
|------------------|--|---------------------|--|
| Amplifiers | amplifier.ti.com | Audio | www.ti.com/audio |
| Data Converters | dataconverter.ti.com | Automotive | www.ti.com/automotive |
| DSP | dsp.ti.com | Broadband | www.ti.com/broadband |
| Interface | interface.ti.com | Digital Control | www.ti.com/digitalcontrol |
| Logic | logic.ti.com | Military | www.ti.com/military |
| Power Mgmt | power.ti.com | Optical Networking | www.ti.com/opticalnetwork |
| Microcontrollers | microcontroller.ti.com | Security | www.ti.com/security |
| | | Telephony | www.ti.com/telephony |
| | | Video & Imaging | www.ti.com/video |
| | | Wireless | www.ti.com/wireless |

Mailing Address: Texas Instruments
Post Office Box 655303 Dallas, Texas 75265