

TLC393-Q1

DUAL MICROPPOWER LinCMOS™ VOLTAGE COMPARATOR

SGLS198 – SEPTEMBER 2004

- **Qualification in Accordance With AEC-Q100†**
- **Qualified for Automotive Applications**
- **Customer-Specific Configuration Control Can Be Supported Along With Major-Change Approval**
- **ESD Protection Exceeds 500 V Per MIL-STD-883, Method 3015; Exceeds 50 V Using Machine Model (C = 200 pF, R = 0)**
- **Low Power . . . 110 μ W Typ at 5 V**
- **Fast Response Time . . . $t_{PLH} = 2.5 \mu$ s Typ With 5-mV Overdrive**
- **Single Supply Operation:
TLC393Q . . . 4 V to 16 V**

† Contact Texas Instruments for details. Q100 qualification data available on request.

D OR PW PACKAGE
(TOP VIEW)

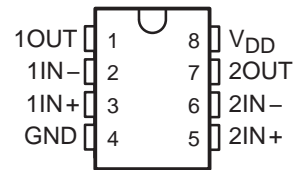

symbol (each comparator)

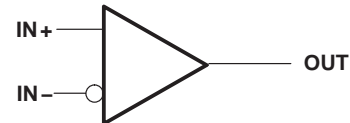

description/ordering information

The TLC393 consists of dual independent micropower voltage comparators designed to operate from a single supply. It is functionally similar to the LM393 but uses one-twentieth the power for similar response times. The open-drain MOS output stage interfaces to a variety of loads and supplies. For a similar device with a push-pull output configuration see the TLC3702 data sheet.

Texas Instruments LinCMOS™ process offers superior analog performance to standard CMOS processes. Along with the standard CMOS advantages of low power without sacrificing speed, high input impedance, and low bias currents, the LinCMOS™ process offers extremely stable input offset voltages, even with differential input stresses of several volts. This characteristic makes it possible to build reliable CMOS comparators.

The TLC393Q is characterized for operation over the full automotive temperature range of $T_A = -40^\circ\text{C}$ to 125°C .

ORDERING INFORMATION

T _A	V _{IO} max AT 25°C	PACKAGE‡		ORDERABLE PART NUMBER	TOP-SIDE MARKING
		SOIC (D)	Tape and reel		
-40°C to 125°C	5 mV	TSSOP (PW)	Tape and reel	TLC393QDRQ1	C393Q1
				TLC393QPWRQ1§	

‡ Package drawings, standard packing quantities, thermal data, symbolization, and PCB design guidelines are available at www.ti.com/sc/package.

§ Product Preview

schematic

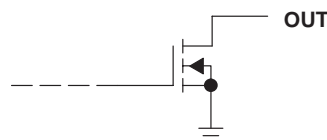

OPEN-DRAIN CMOS OUTPUT



Please be aware that an important notice concerning availability, standard warranty, and use in critical applications of Texas Instruments semiconductor products and disclaimers thereto appears at the end of this data sheet.

LinCMOS is a trademark of Texas Instruments Incorporated.

PRODUCTION DATA information is current as of publication date. Products conform to specifications per the terms of Texas Instruments standard warranty. Production processing does not necessarily include testing of all parameters.



POST OFFICE BOX 655303 • DALLAS, TEXAS 75265

Copyright © 2003, Texas Instruments Incorporated

TLC393-Q1

DUAL MICROPOWER LinCMOS™ VOLTAGE COMPARATOR

SGLS198 – SEPTEMBER 2004

absolute maximum ratings over operating free-air temperature range (unless otherwise noted)†

Supply voltage range, V_{DD} (see Note 1)	-0.3 V to 18 V
Differential input voltage, V_{ID} (see Note 2)	± 18 V
Input voltage range, V_I	-0.3 V to V_{DD}
Output voltage range, V_O	-0.3 V to 16 V
Input current, I_I	± 5 mA
Output current, I_O (each output)	20 mA
Total supply current into V_{DD}	40 mA
Total current out of GND	40 mA
Package thermal impedance, θ_{JA} (see Notes 3 and 4): D package	126°C/W
PW package	149°C/W
Operating free-air temperature range: TLC393Q	-40°C to 125°C
Storage temperature range	-65°C to 150°C
Lead temperature 1,6 mm (1/16 inch) from case for 10 seconds: D package	260°C

† Stresses beyond those listed under “absolute maximum ratings” may cause permanent damage to the device. These are stress ratings only, and functional operation of the device at these or any other conditions beyond those indicated under “recommended operating conditions” is not implied. Exposure to absolute-maximum-rated conditions for extended periods may affect device reliability.

- NOTES:
1. All voltage values, except differential voltages, are with respect to network ground.
 2. Differential voltages are at $IN+$ with respect to $IN-$.
 3. Maximum power dissipation is a function of $T_J(\text{max})$, θ_{JA} , and T_A . The maximum allowable power dissipation at any allowable ambient temperature is $P_D = (T_J(\text{max}) - T_A)/\theta_{JA}$. Operating at the absolute maximum T_J of 150°C can affect reliability.
 4. The package thermal impedance is calculated in accordance with JESD 51-7.

recommended operating conditions

	MIN	NOM	MAX	UNIT
Supply voltage, V_{DD}	4	5	16	V
Common-mode input voltage, V_{IC}	0		$V_{DD} - 1.5$	V
Low-level output current, I_{OL}			20	mA
Operating free-air temperature, T_A	-40		125	°C



TLC393-Q1

DUAL MICROPOWER LinCMOS™ VOLTAGE COMPARATOR

SGLS198 – SEPTEMBER 2004

electrical characteristics at specified operating free-air temperature, $V_{DD} = 5\text{ V}$ (unless otherwise noted)

PARAMETER		TEST CONDITIONS†	T_A	MIN	TYP	MAX	UNIT
V_{IO}	Input offset voltage	$V_{IC} = V_{ICRmin}$, $V_{DD} = 5\text{ V to }10\text{ V}$, See Note 4	25°C		1.4	5	mV
			-40°C to 125°C			10	
I_{IO}	Input offset current	$V_{IC} = 2.5\text{ V}$	25°C		1		pA
			125°C			15	nA
I_{IB}	Input bias current	$V_{IC} = 2.5\text{ V}$	25°C		5		pA
			125°C			30	nA
V_{ICR}	Common-mode input voltage range		25°C	0 to $V_{DD} - 1$			V
			-40°C to 125°C	0 to $V_{DD} - 1.5$			
CMMR	Common-mode rejection ratio	$V_{IC} = V_{ICRmin}$	25°C	84			dB
			125°C	84			
			-40°C	84			
k_{SVR}	Supply-voltage rejection ratio	$V_{DD} = 5\text{ V to }10\text{ V}$	25°C	85			dB
			125°C	84			
			-40°C	84			
V_{OL}	Low-level output voltage	$V_{ID} = -1\text{ V}$, $I_{OL} = 6\text{ mA}$	25°C	300	400		mV
			125°C		800		
I_{OH}	High-level output current	$V_{ID} = 1\text{ V}$, $V_O = 5\text{ V}$	25°C	0.8	40		nA
			125°C		1		μA
I_{DD}	Supply current (both comparators)	Outputs low, No load	25°C	22	40		μA
			-40°C to 125°C			90	

† All characteristics are measured with zero common-mode voltage unless otherwise noted.

NOTE 5: The offset voltage limits given are the maximum values required to drive the output up to 4.5 V or down to 0.3 V (with a 2.5-k Ω load to V_{DD}).

TLC393-Q1

DUAL MICROPOWER LinCMOS™ VOLTAGE COMPARATOR

SGLS198 – SEPTEMBER 2004

switching characteristics, $V_{DD} = 5\text{ V}$, $T_A = 25^\circ\text{C}$ (see Figure 3)

PARAMETER		TEST CONDITIONS	MIN	TYP	MAX	UNIT
t_{PLH}	Propagation delay time, low-to-high level output	$f = 10\text{ kHz}$, $C_L = 15\text{ pF}$	Overdrive = 2 mV	4.5		μs
			Overdrive = 5 mV	2.5		
			Overdrive = 10 mV	1.7		
			Overdrive = 20 mV	1.2		
			Overdrive = 40 mV	1.1		
t_{PHL}	Propagation delay time, high-to-low level output	$f = 10\text{ kHz}$, $C_L = 15\text{ pF}$	$V_I = 1.4\text{-V}$ step at $IN+$	1.1		μs
			Overdrive = 2 mV	3.6		
			Overdrive = 5 mV	2.1		
			Overdrive = 10 mV	1.3		
			Overdrive = 20 mV	0.85		
			Overdrive = 40 mV	0.55		
t_f	Fall time, output	$f = 10\text{ kHz}$, $C_L = 15\text{ pF}$	$V_I = 1.4\text{-V}$ step at $IN+$	0.10		ns
			Overdrive = 50 mV	22		

PARAMETER MEASUREMENT INFORMATION

The TLC393 contains a digital output stage which, if held in the linear region of the transfer curve, can cause damage to the device. Conventional operational amplifier/comparator testing incorporates the use of a servo loop that is designed to force the device output to a level within this linear region. Since the servo-loop method of testing cannot be used, the following alternatives for testing parameters such as input offset voltage, common-mode rejection ratio, etc., are suggested.

To verify that the input offset voltage falls within the limits specified, the limit value is applied to the input as shown in Figure 1(a). With the noninverting input positive with respect to the inverting input, the output should be high. With the input polarity reversed, the output should be low.

A similar test can be made to verify the input offset voltage at the common-mode extremes. The supply voltages can be slewed as shown in Figure 1(b) for the V_{ICR} test, rather than changing the input voltages, to provide greater accuracy.

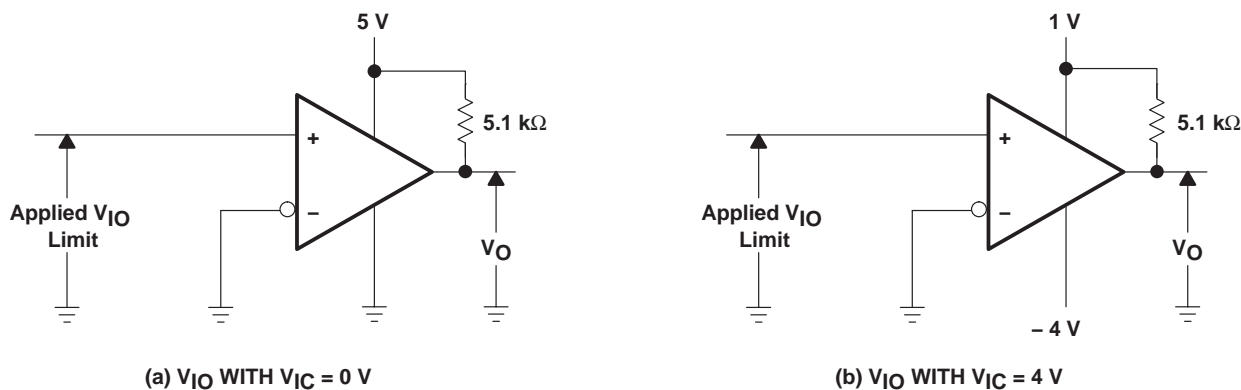

Figure 1. Method for Verifying That Input Offset Voltage Is Within Specified Limits

PARAMETER MEASUREMENT INFORMATION

A close approximation of the input offset voltage can be obtained by using a binary search method to vary the differential input voltage while monitoring the output state. When the applied input voltage differential is equal, but opposite in polarity, to the input offset voltage, the output changes states.

Figure 2 illustrates a practical circuit for direct dc measurement of input offset voltage that does not bias the comparator in the linear region. The circuit consists of a switching-mode servo loop in which U1A generates a triangular waveform of approximately 20-mV amplitude. U1B acts as a buffer, with C2 and R4 removing any residual dc offset. The signal is then applied to the inverting input of the comparator under test, while the noninverting input is driven by the output of the integrator formed by U1C through the voltage divider formed by R9 and R10. The loop reaches a stable operating point when the output of the comparator under test has a duty cycle of exactly 50%, which can only occur when the incoming triangle wave is sliced symmetrically or when the voltage at the noninverting input exactly equals the input offset voltage.

The voltage divider formed by R9 and R10 provides an increase in input offset voltage by a factor of 100 to make measurement easier. The values of R5, R8, R9, and R10 can significantly influence the accuracy of the reading; therefore, it is suggested that their tolerance level be 1% or lower.

Measuring the extremely low values of input current requires isolation from all other sources of leakage current and compensation for the leakage of the test socket and board. With a good picoammeter, the socket and board leakage can be measured with no device in the socket. Subsequently, this open-socket leakage value can be subtracted from the measurement obtained with a device in the socket to obtain the actual input current of the device.

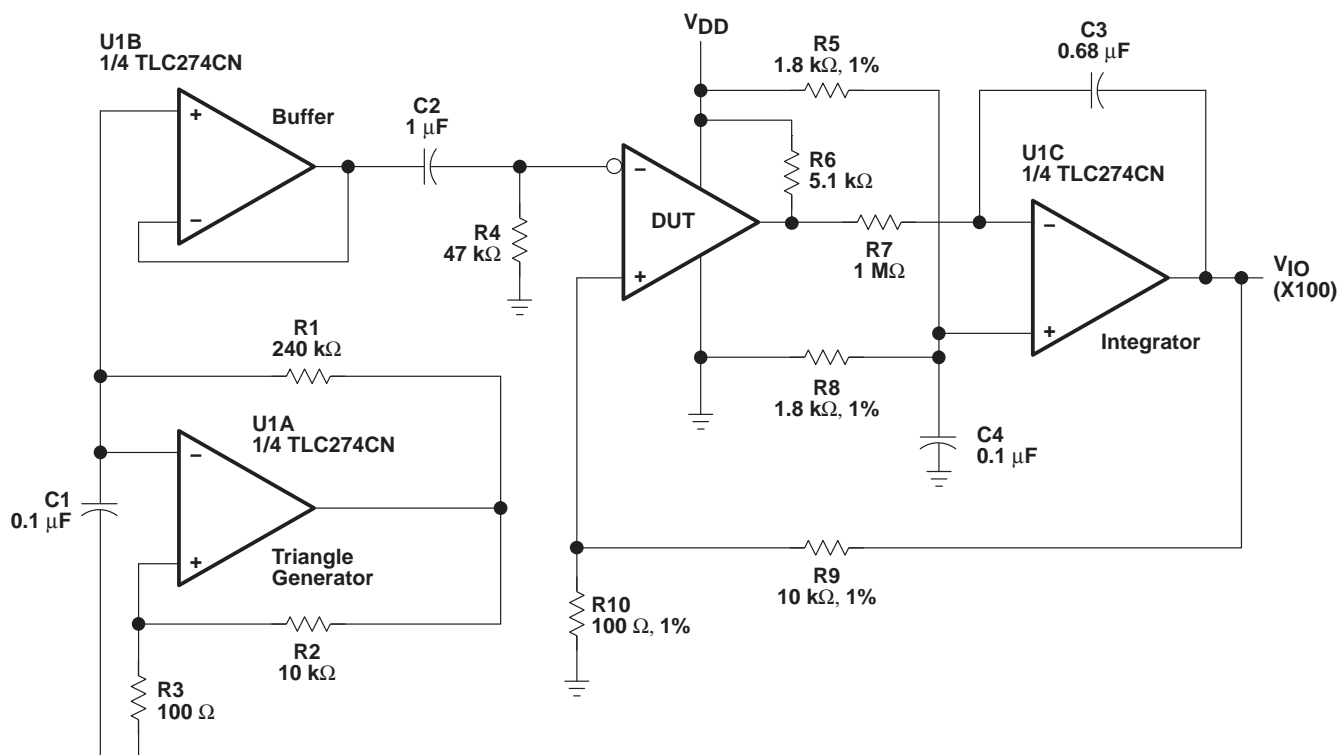

Figure 2. Circuit for Input Offset Voltage Measurement

TLC393-Q1 DUAL MICROPOWER LinCMOS™ VOLTAGE COMPARATOR

SGLS198 – SEPTEMBER 2004

PARAMETER MEASUREMENT INFORMATION

Propagation delay time is defined as the interval between the application of an input step function and the instant when the output reaches 50% of its maximum value. Propagation delay time, low-to-high level output, is measured from the leading edge of the input pulse, while propagation delay time, high-to-low level output, is measured from the trailing edge of the input pulse. Propagation delay time measurement at low input signal levels can be greatly affected by the input offset voltage. The offset voltage should be balanced by the adjustment at the inverting input (as shown in Figure 3) so that the circuit is just at the transition point. Then a low signal, for example, 105 mV or 5 mV overdrive, causes the output to change state.

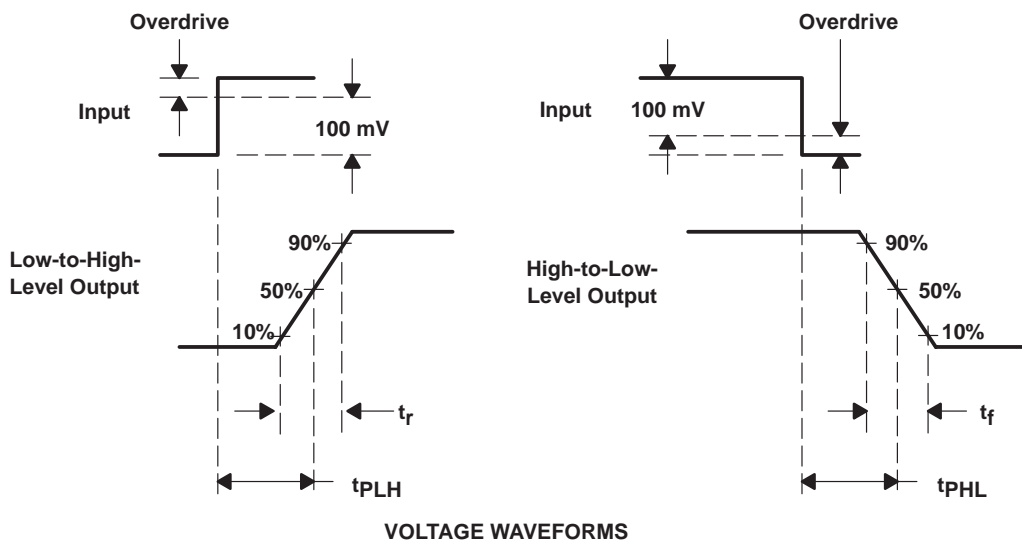
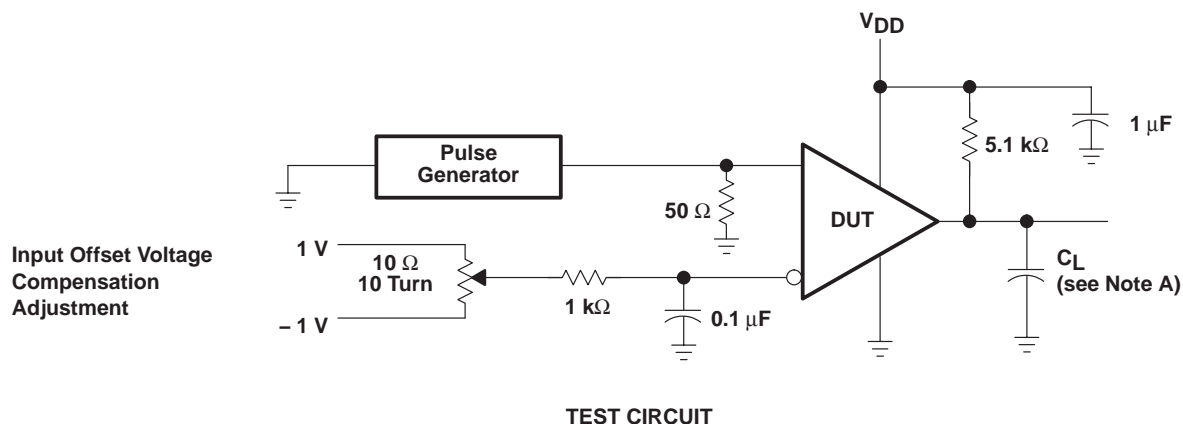

NOTE A: C_L includes probe and jig capacitance.

Figure 3. Propagation Delay, Rise Time, and Fall Time Circuit and Voltage Waveforms

TYPICAL CHARACTERISTICS

Table of Graphs

			FIGURE
V_{IO}	Input offset voltage	Distribution	4
I_{IB}	Input bias current	vs Free-air temperature	5
CMRR	Common-mode rejection ratio	vs Free-air temperature	6
k_{SVR}	Supply-voltage rejection ratio	vs Free-air temperature	7
V_{OL}	Low-level output voltage	vs Low-level output current vs Free-air temperature	8 9
I_{OH}	Low-level output current	vs High-level output voltage vs Free-air temperature	10 11
I_{DD}	Supply current	vs Supply voltage vs Free-air temperature	12 13
t_{PLH}	Low-to-high level output propagation delay time	vs Supply voltage	14
t_{PHL}	High-to-low level output propagation delay time	vs Supply voltage	15
	Low-to-high-level output response	Low-to-high level output propagation delay time	16
	High-to-low level output response	High-to-low level output propagation delay time	17
t_f	Fall time	vs Supply voltage	18

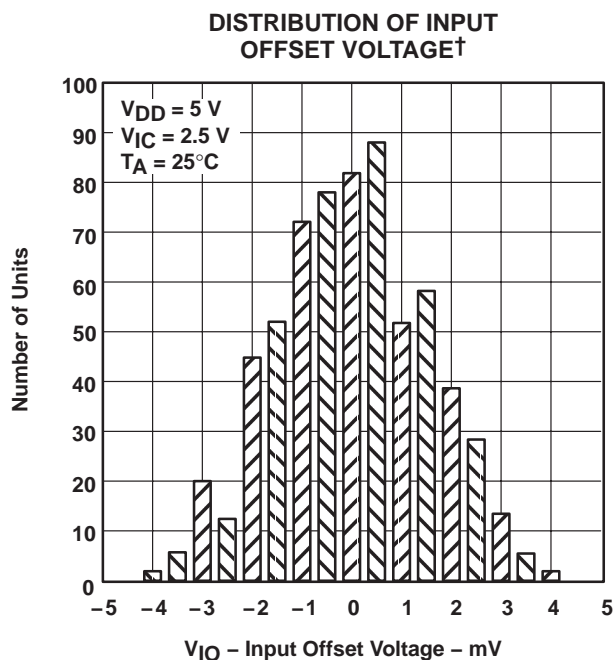

Figure 4

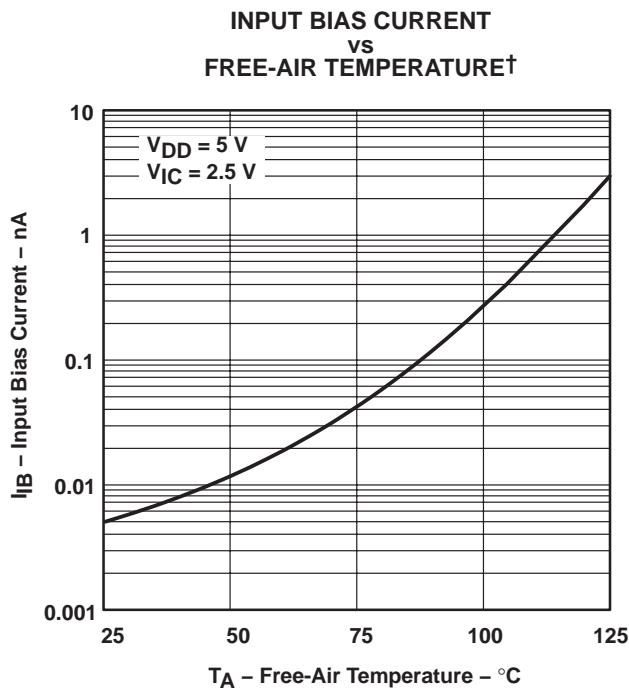

Figure 5

† Data at high and low temperatures are applicable only within the rated operating free-air temperature ranges of the various devices.

TLC393-Q1 DUAL MICROPOWER LinCMOS™ VOLTAGE COMPARATOR

SGLS198 – SEPTEMBER 2004

TYPICAL CHARACTERISTICS†

COMMON-MODE REJECTION RATIO
vs
FREE-AIR TEMPERATURE

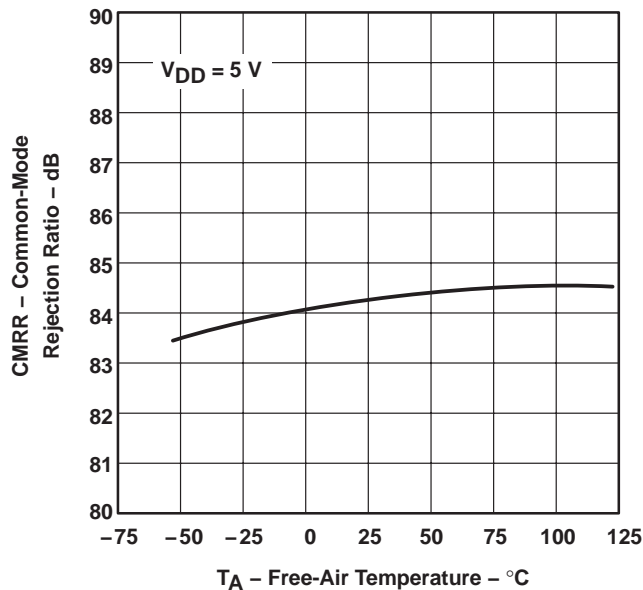

Figure 6

SUPPLY VOLTAGE REJECTION RATIO
vs
FREE-AIR TEMPERATURE

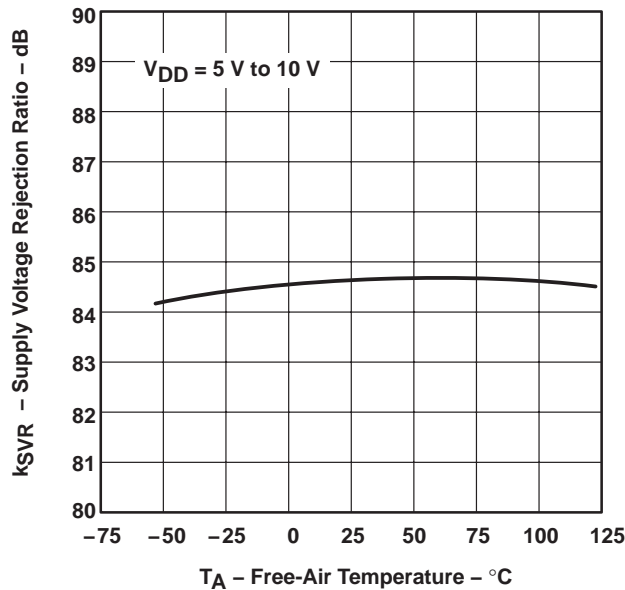

Figure 7

LOW-LEVEL OUTPUT VOLTAGE
vs
LOW-LEVEL OUTPUT CURRENT

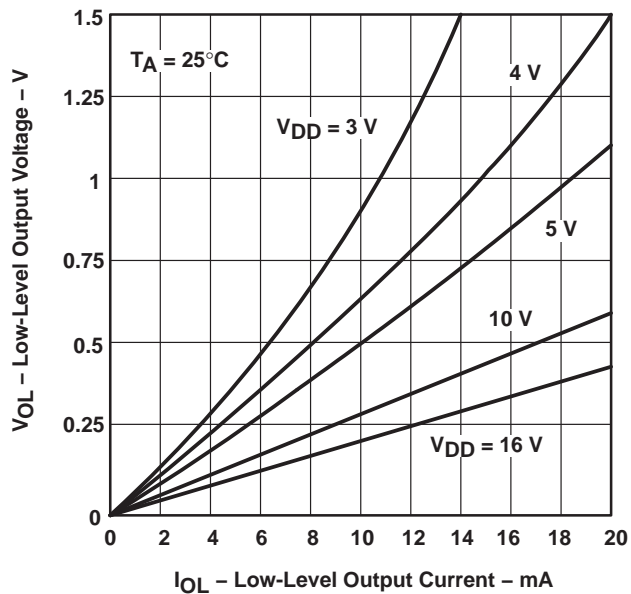

Figure 8

LOW-LEVEL OUTPUT VOLTAGE
vs
FREE-AIR TEMPERATURE

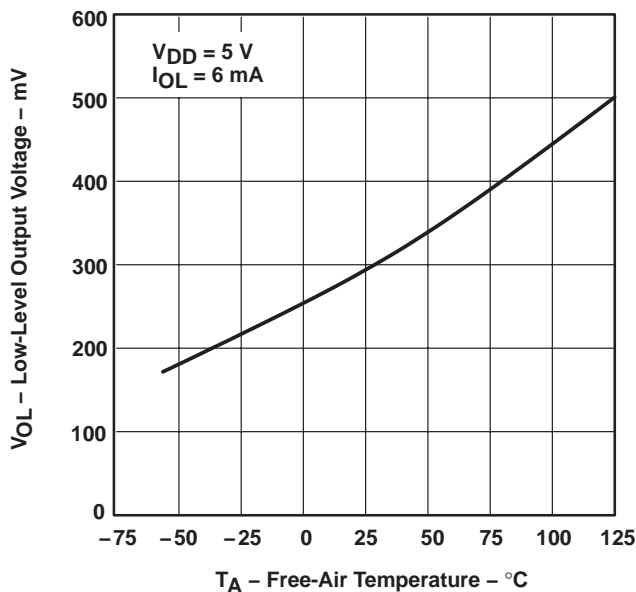

Figure 9

† Data at high and low temperatures are applicable only within the rated operating free-air temperature ranges of the various devices.



TYPICAL CHARACTERISTICS†

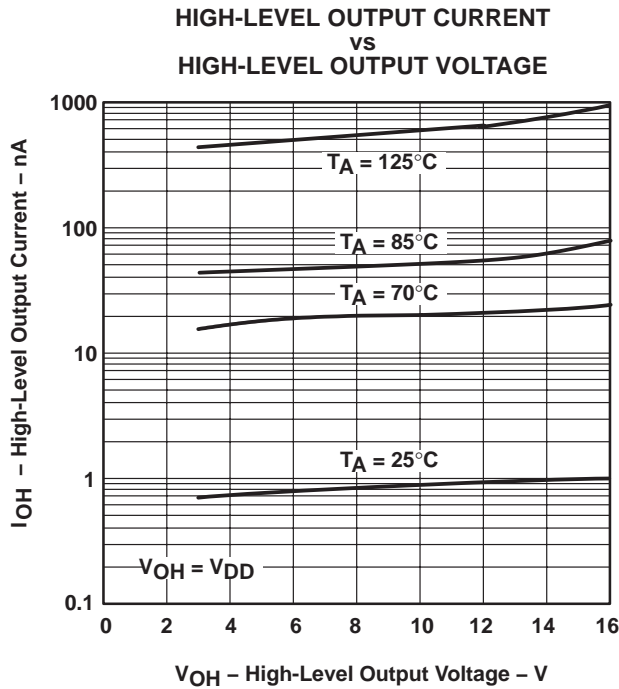

Figure 10

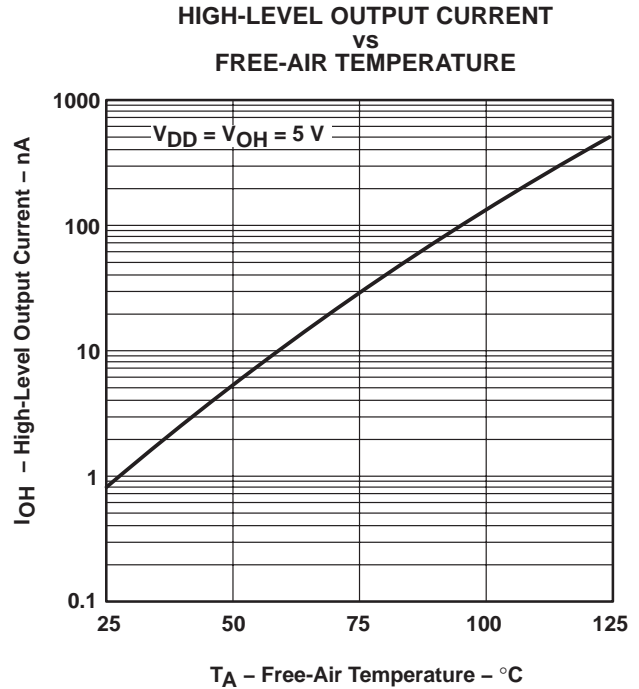

Figure 11

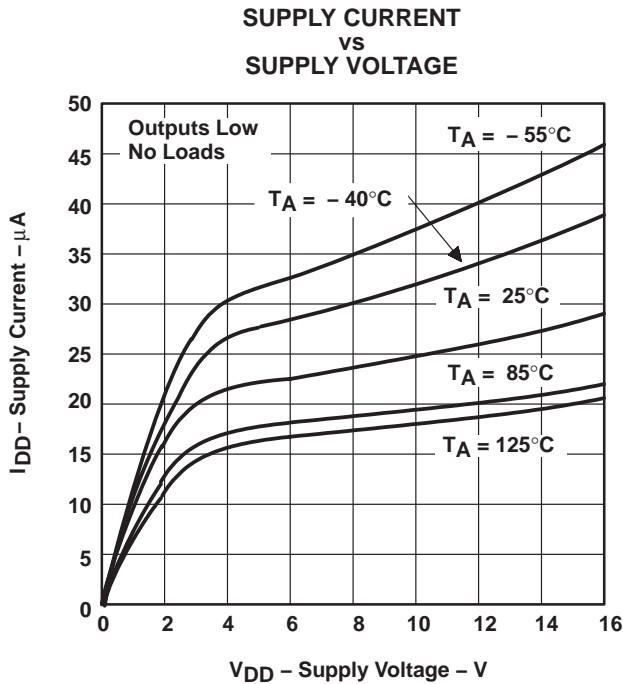

Figure 12

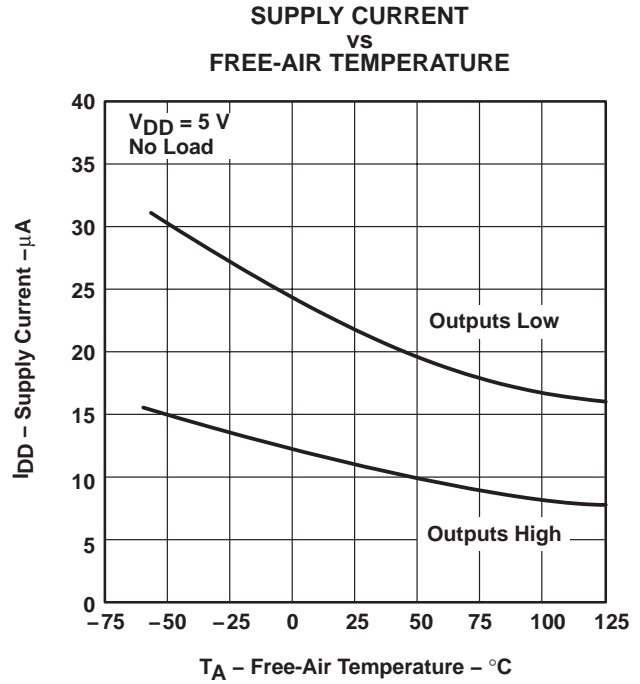

Figure 13

† Data at high and low temperatures are applicable only within the rated operating free-air temperature ranges of the various devices.

TLC393-Q1 DUAL MICROPOWER LinCMOS™ VOLTAGE COMPARATOR

SGLS198 – SEPTEMBER 2004

TYPICAL CHARACTERISTICS

LOW-TO-HIGH-LEVEL
OUTPUT RESPONSE TIME
VS
SUPPLY VOLTAGE

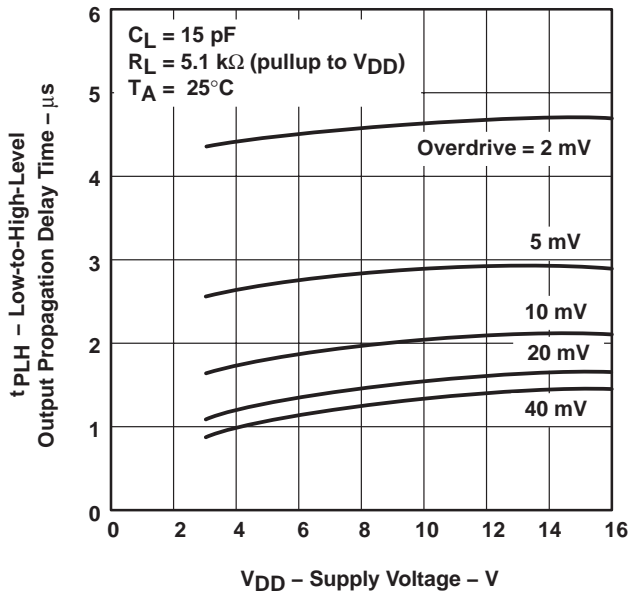

Figure 14

HIGH-TO-LOW-LEVEL
OUTPUT RESPONSE TIME
VS
SUPPLY VOLTAGE

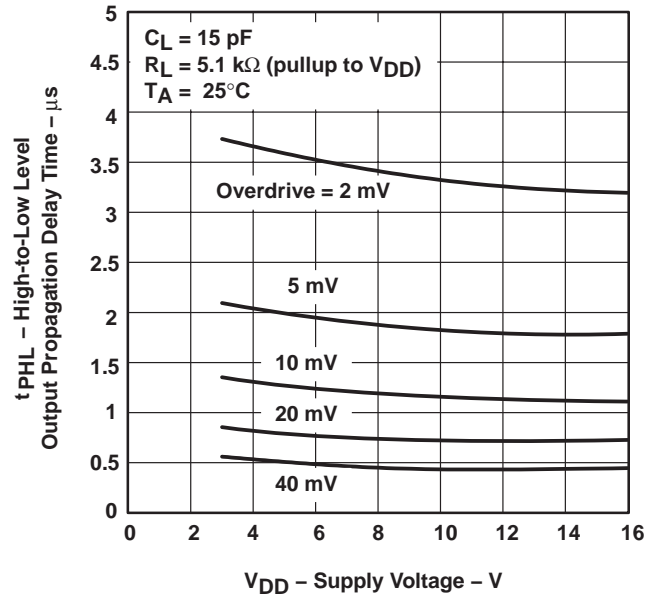

Figure 15

LOW-TO-HIGH-LEVEL OUTPUT
PROPAGATION DELAY
FOR VARIOUS INPUT OVERDRIVES

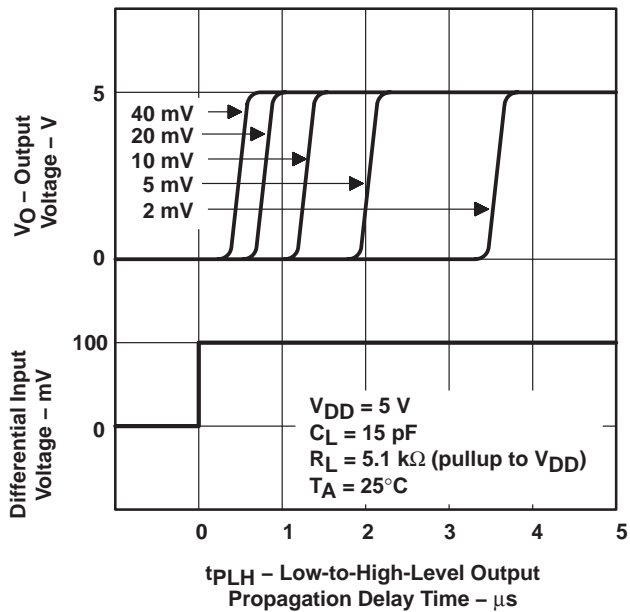

Figure 16

HIGH-TO-LOW-LEVEL OUTPUT
PROPAGATION DELAY
FOR VARIOUS INPUT OVERDRIVES

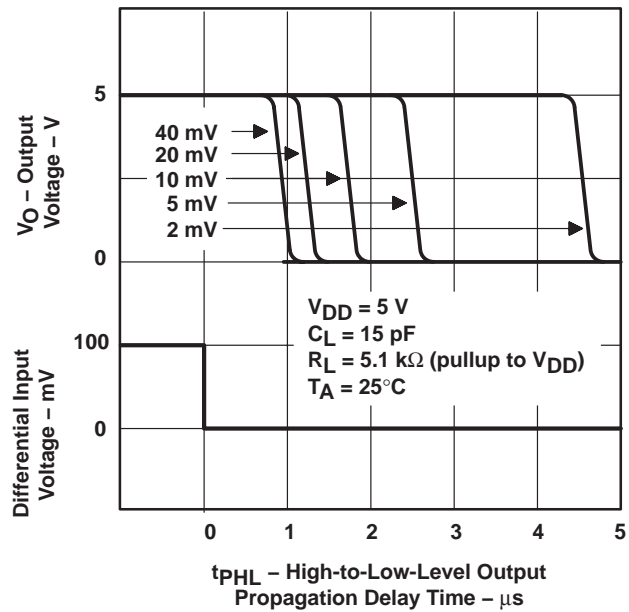

Figure 17



TYPICAL CHARACTERISTICS

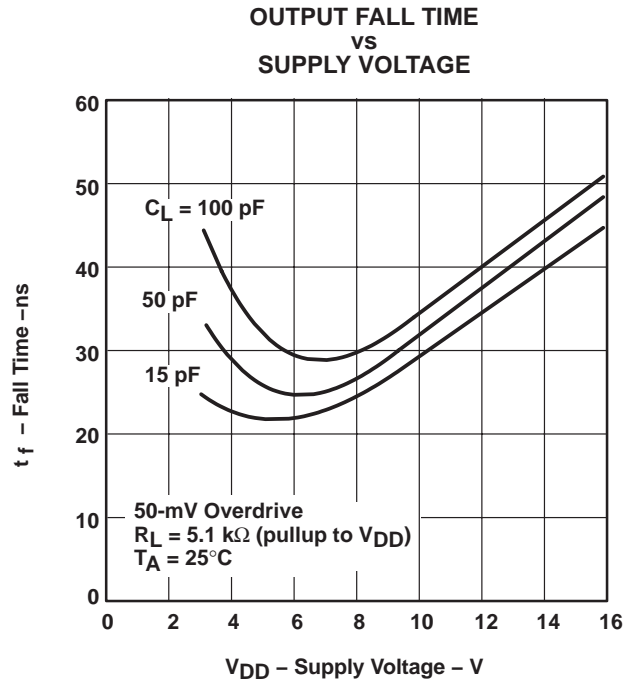

Figure 18

APPLICATION INFORMATION

The input should always remain within the supply rails in order to avoid forward biasing the diodes in the electrostatic discharge (ESD) protection structure. If either input exceeds this range, the device will not be damaged as long as the input current is limited to less than 5 mA. To maintain the expected output state, the inputs must remain within the common-mode range. For example, at 25°C with $V_{DD} = 5\text{ V}$, both inputs must remain between -0.2 V and 4 V to assure proper device operation.

To assure reliable operation, the supply should be decoupled with a capacitor ($0.1\text{-}\mu\text{F}$) positioned as close to the device as possible.

The TLC393 has internal ESD-protection circuits that prevent functional failures at voltages up to 2000 V as tested under MIL-STD-883C, Method 3015.2; however, care should be exercised in handling these devices, as exposure to ESD may result in the degradation of the device parametric performance.

Table of Applications

	FIGURE
Pulse-width-modulated motor speed controller	19
Enhanced supply supervisor	20
Two-phase nonoverlapping clock generator	21
Micropower switching regulator	28

TLC393-Q1 DUAL MICROPPOWER LinCMOS™ VOLTAGE COMPARATOR

SGLS198 – SEPTEMBER 2004

APPLICATION INFORMATION

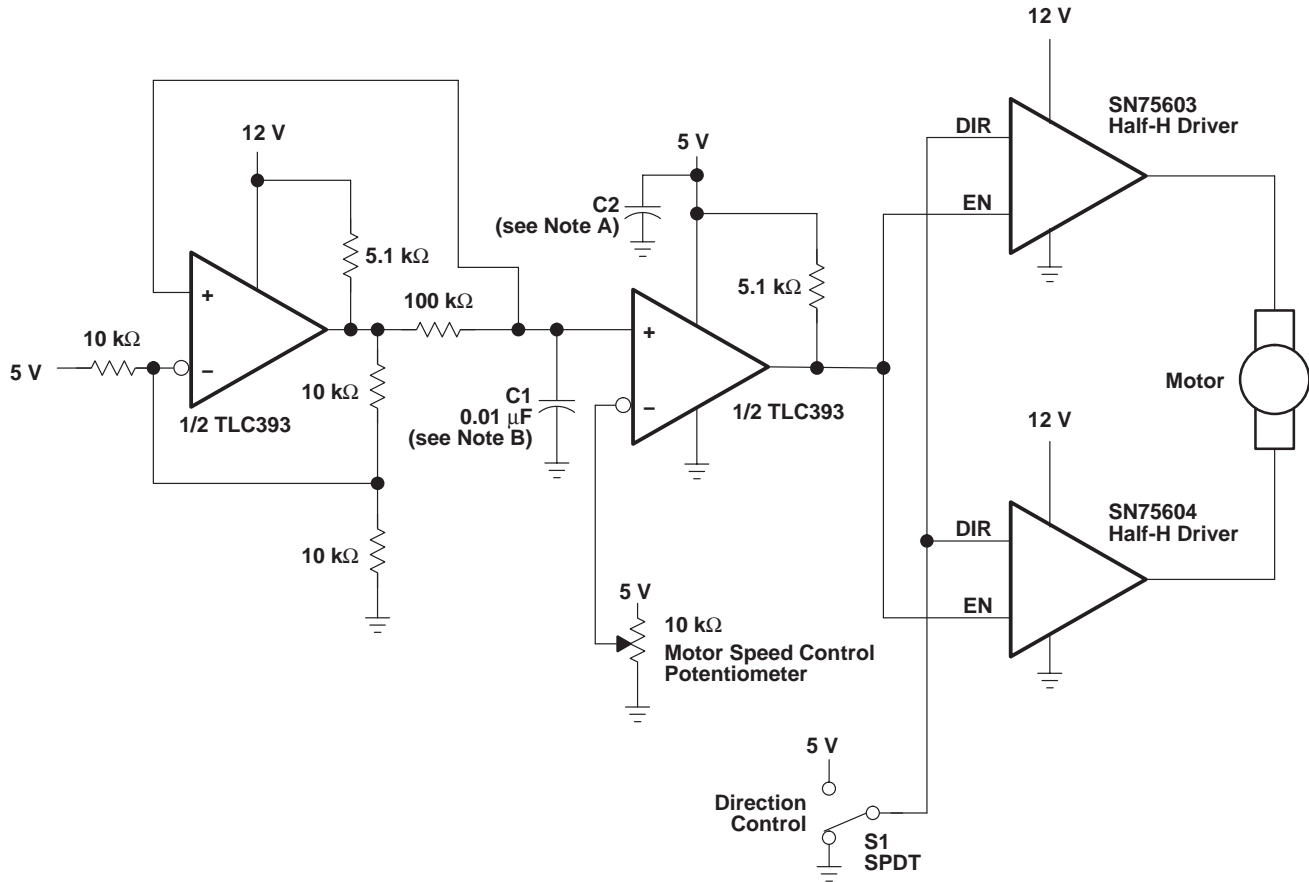

NOTES: A. The recommended minimum capacitance is 10 µF to eliminate common ground switching noise.
B. Adjust C1 for change in oscillator frequency.

Figure 19. Pulse-Width-Modulated Motor Speed Controller

APPLICATION INFORMATION

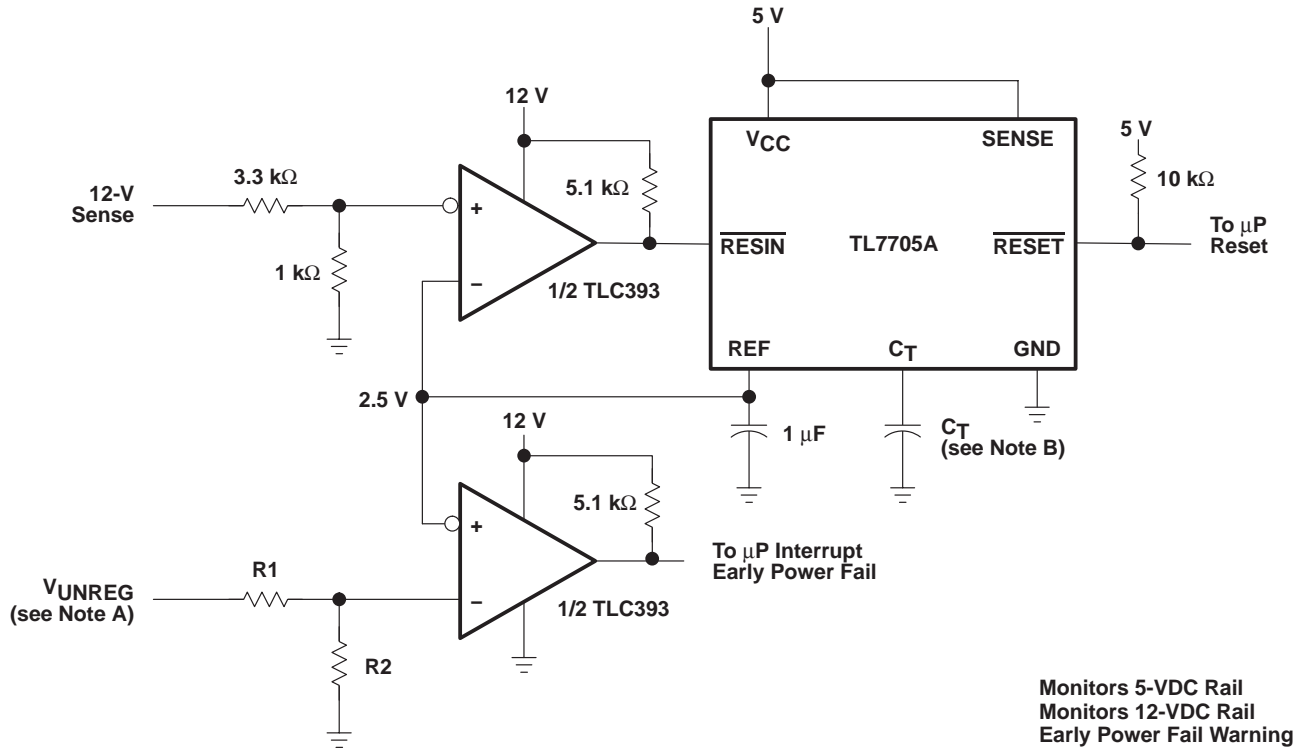

- NOTES: A. $V_{UNREG} = 2.5 \frac{(R1 + R2)}{R2}$
 B. The value of C_T determines the time delay of reset.

Figure 20. Enhanced Supply Supervisor

TLC393-Q1

DUAL MICROPOWER LinCMOS™ VOLTAGE COMPARATOR

SGLS198 – SEPTEMBER 2004

APPLICATION INFORMATION

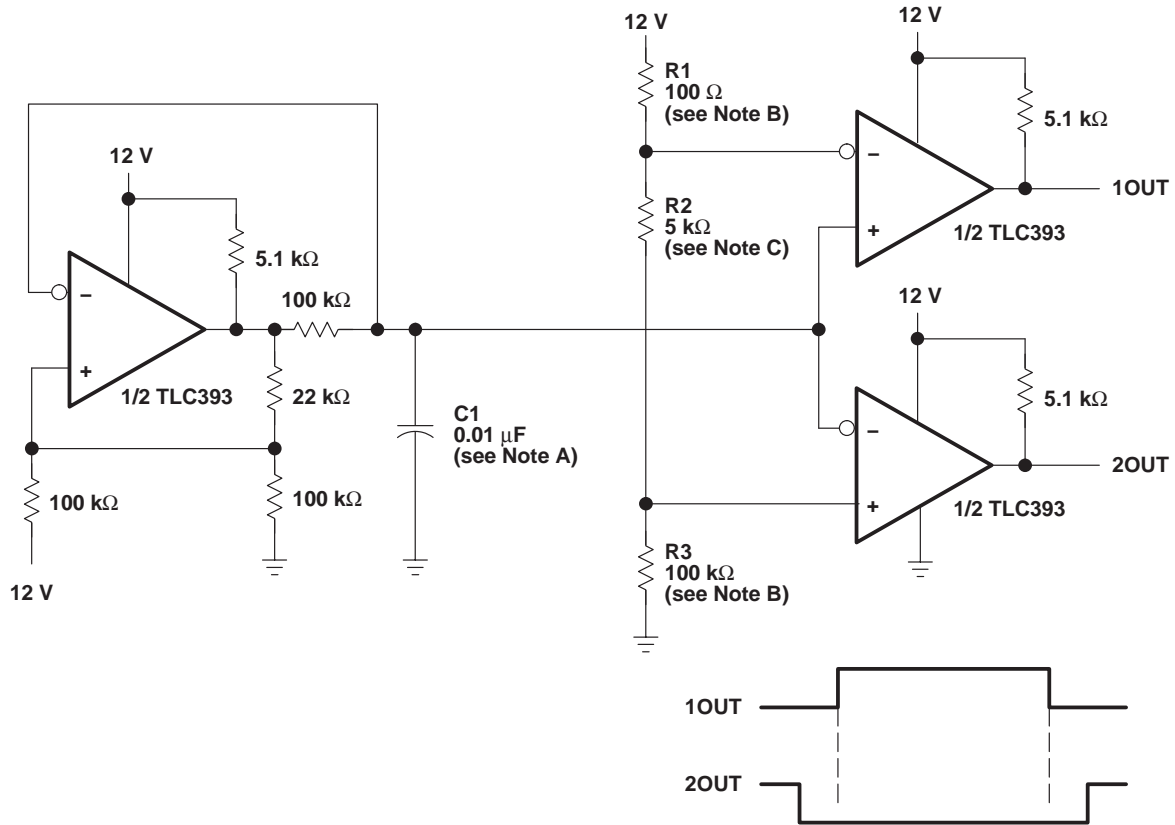

- NOTES: A. Adjust C1 for a change in oscillator frequency where:
 $1/f = 1.85(100 \text{ k}\Omega)C1$
 B. Adjust R1 and R3 to change duty cycle
 C. Adjust R2 to change deadtime

Figure 21. Two-Phase Nonoverlapping Clock Generator

PACKAGING INFORMATION

Orderable Device	Status ⁽¹⁾	Package Type	Package Drawing	Pins	Package Qty	Eco Plan ⁽²⁾	Lead/Ball Finish	MSL Peak Temp ⁽³⁾
TLC393QDRQ1	ACTIVE	SOIC	D	8	2500	Pb-Free (RoHS)	CU NIPDAU	Level-2-250C-1 YEAR/ Level-1-235C-UNLIM

⁽¹⁾ The marketing status values are defined as follows:

ACTIVE: Product device recommended for new designs.

LIFEBUY: TI has announced that the device will be discontinued, and a lifetime-buy period is in effect.

NRND: Not recommended for new designs. Device is in production to support existing customers, but TI does not recommend using this part in a new design.

PREVIEW: Device has been announced but is not in production. Samples may or may not be available.

OBSOLETE: TI has discontinued the production of the device.

⁽²⁾ Eco Plan - May not be currently available - please check <http://www.ti.com/productcontent> for the latest availability information and additional product content details.

None: Not yet available Lead (Pb-Free).

Pb-Free (RoHS): TI's terms "Lead-Free" or "Pb-Free" mean semiconductor products that are compatible with the current RoHS requirements for all 6 substances, including the requirement that lead not exceed 0.1% by weight in homogeneous materials. Where designed to be soldered at high temperatures, TI Pb-Free products are suitable for use in specified lead-free processes.

Green (RoHS & no Sb/Br): TI defines "Green" to mean "Pb-Free" and in addition, uses package materials that do not contain halogens, including bromine (Br) or antimony (Sb) above 0.1% of total product weight.

⁽³⁾ MSL, Peak Temp. -- The Moisture Sensitivity Level rating according to the JEDEC industry standard classifications, and peak solder temperature.

Important Information and Disclaimer: The information provided on this page represents TI's knowledge and belief as of the date that it is provided. TI bases its knowledge and belief on information provided by third parties, and makes no representation or warranty as to the accuracy of such information. Efforts are underway to better integrate information from third parties. TI has taken and continues to take reasonable steps to provide representative and accurate information but may not have conducted destructive testing or chemical analysis on incoming materials and chemicals. TI and TI suppliers consider certain information to be proprietary, and thus CAS numbers and other limited information may not be available for release.

In no event shall TI's liability arising out of such information exceed the total purchase price of the TI part(s) at issue in this document sold by TI to Customer on an annual basis.

D (R-PDSO-G8)

PLASTIC SMALL-OUTLINE PACKAGE

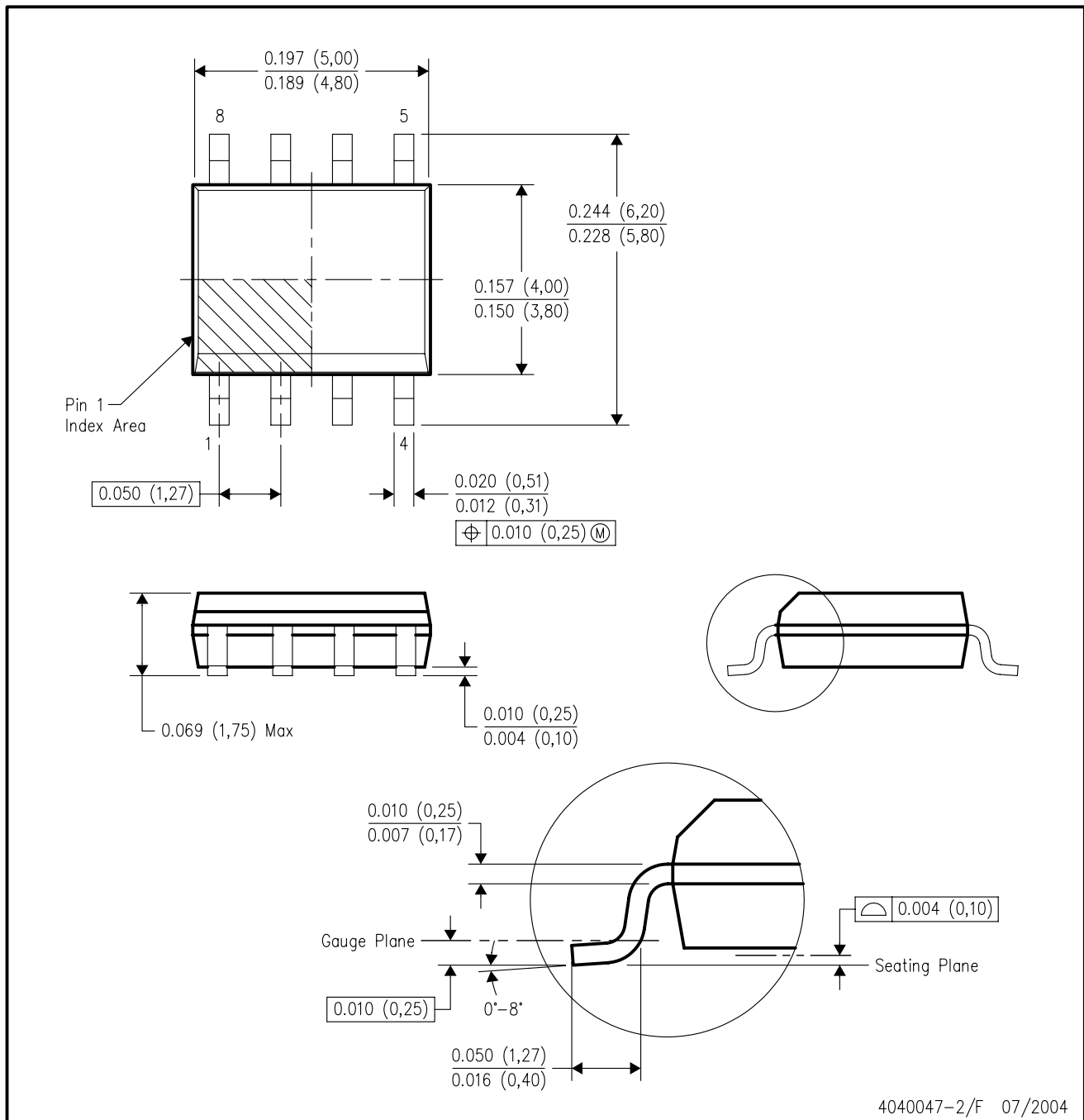

- NOTES:
- A. All linear dimensions are in inches (millimeters).
 - B. This drawing is subject to change without notice.
 - C. Body dimensions do not include mold flash or protrusion not to exceed 0.006 (0,15).
 - D. Falls within JEDEC MS-012 variation AA.

IMPORTANT NOTICE

Texas Instruments Incorporated and its subsidiaries (TI) reserve the right to make corrections, modifications, enhancements, improvements, and other changes to its products and services at any time and to discontinue any product or service without notice. Customers should obtain the latest relevant information before placing orders and should verify that such information is current and complete. All products are sold subject to TI's terms and conditions of sale supplied at the time of order acknowledgment.

TI warrants performance of its hardware products to the specifications applicable at the time of sale in accordance with TI's standard warranty. Testing and other quality control techniques are used to the extent TI deems necessary to support this warranty. Except where mandated by government requirements, testing of all parameters of each product is not necessarily performed.

TI assumes no liability for applications assistance or customer product design. Customers are responsible for their products and applications using TI components. To minimize the risks associated with customer products and applications, customers should provide adequate design and operating safeguards.

TI does not warrant or represent that any license, either express or implied, is granted under any TI patent right, copyright, mask work right, or other TI intellectual property right relating to any combination, machine, or process in which TI products or services are used. Information published by TI regarding third-party products or services does not constitute a license from TI to use such products or services or a warranty or endorsement thereof. Use of such information may require a license from a third party under the patents or other intellectual property of the third party, or a license from TI under the patents or other intellectual property of TI.

Reproduction of information in TI data books or data sheets is permissible only if reproduction is without alteration and is accompanied by all associated warranties, conditions, limitations, and notices. Reproduction of this information with alteration is an unfair and deceptive business practice. TI is not responsible or liable for such altered documentation.

Resale of TI products or services with statements different from or beyond the parameters stated by TI for that product or service voids all express and any implied warranties for the associated TI product or service and is an unfair and deceptive business practice. TI is not responsible or liable for any such statements.

Following are URLs where you can obtain information on other Texas Instruments products and application solutions:

Products		Applications	
Amplifiers	amplifier.ti.com	Audio	www.ti.com/audio
Data Converters	dataconverter.ti.com	Automotive	www.ti.com/automotive
DSP	dsp.ti.com	Broadband	www.ti.com/broadband
Interface	interface.ti.com	Digital Control	www.ti.com/digitalcontrol
Logic	logic.ti.com	Military	www.ti.com/military
Power Mgmt	power.ti.com	Optical Networking	www.ti.com/opticalnetwork
Microcontrollers	microcontroller.ti.com	Security	www.ti.com/security
		Telephony	www.ti.com/telephony
		Video & Imaging	www.ti.com/video
		Wireless	www.ti.com/wireless

Mailing Address: Texas Instruments
Post Office Box 655303 Dallas, Texas 75265