



1.1-W MONO FILTER-FREE CLASS-D AUDIO POWER AMPLIFIER

FEATURES

- **Maximum Battery Life and Minimum Heat**
 - Efficiency With an 8-Ω Speaker:
 - 84% at 400 mW
 - 79% at 100 mW
 - 2.8-mA Quiescent Current
 - 0.5-μA Shutdown Current
- **Only Three External Components**
 - Optimized PWM Output Stage Eliminates LC Output Filter
 - Internally Generated 250-kHz Switching Frequency Eliminates Capacitor and Resistor
 - Improved PSRR (–71 dB at 217 Hz) and Wide Supply Voltage (2.5 V to 5.5 V) Eliminates Need for a Voltage Regulator
 - Fully Differential Design Reduces RF Rectification and Eliminates Bypass Capacitor
 - Improved CMRR Eliminates Two Input Coupling Capacitors

APPLICATIONS

- **Ideal for Wireless or Cellular Handsets and PDAs**

DESCRIPTION

The TPA2005D1 is a 1.1-W high efficiency filter-free class-D audio power amplifier in a MicroStar Junior™ BGA package that requires only three external components.

Features like 84% efficiency, –71-dB PSRR at 217 Hz, improved RF-rectification immunity, and 15 mm² total PCB area make the TPA2005D1 ideal for cellular handsets. A fast start-up time of 9 ms with minimal pop makes the TPA2005D1 ideal for PDA applications.

In cellular handsets, the earpiece, speaker phone, and melody ringer can each be driven by the TPA2005D1. The device allows independent gain control by summing the signals from each function while minimizing noise to only 48 μV_{RMS}.

APPLICATION CIRCUIT

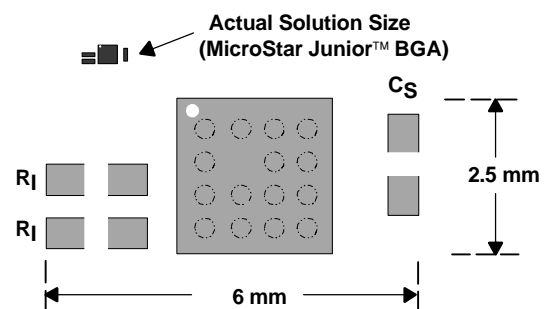
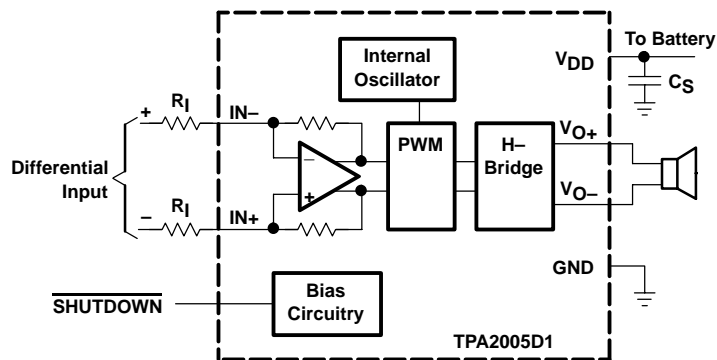

Please be aware that an important notice concerning availability, standard warranty, and use in critical applications of Texas Instruments semiconductor products and disclaimers thereto appears at the end of this data sheet.

MicroStar Junior is a trademark of Texas Instruments.

TPA2005D1

SLOS369B – JULY 2002 – REVISED DECEMBER 2002



This integrated circuit can be damaged by ESD. Texas Instruments recommends that all integrated circuits be handled with appropriate precautions. Failure to observe proper handling and installation procedures can cause damage.

ORDERING INFORMATION

T _A	PACKAGE	PART NUMBER	SYMBOL
-40°C to 85°C	MicroStar Junior™ (GQY)	TPA2005D1GQYR(1)	PB051
	Plastic small outline (DRB)	TPA2005D1DRBR	BIQ

(1) The GQY package is only available taped and reeled.

ABSOLUTE MAXIMUM RATINGS

over operating free-air temperature range unless otherwise noted(1)

		TPA2005D1	UNIT
Supply voltage, V _{DD}	In active mode	-0.3 V to 6 V	V
	In $\overline{\text{SHUTDOWN}}$ mode	-0.3 V to 7 V	V
Input voltage, V _I		-0.3 V to V _{DD} + 0.3 V	V
Continuous total power dissipation		See Dissipation Rating Table	
Operating free-air temperature, T _A		-40 to 85	°C
Operating junction temperature, T _J		-40 to 150	°C
Storage temperature, T _{stg}		-65 to 150	°C
Lead temperature 1,6 mm (1/16 inch) from case for 10 seconds		260	°C

(1) Stresses beyond those listed under "absolute maximum ratings" may cause permanent damage to the device. These are stress ratings only, and functional operation of the device at these or any other conditions beyond those indicated under "recommended operating conditions" is not implied. Exposure to absolute-maximum-rated conditions for extended periods may affect device reliability.

RECOMMENDED OPERATING CONDITIONS

		MIN	NOM	MAX	UNIT
Supply voltage, V _{DD}		2.5		5.5	V
High-level input voltage, V _{IH}	$\overline{\text{SHUTDOWN}}$	2		V _{DD}	V
Low-level input voltage, V _{IL}	$\overline{\text{SHUTDOWN}}$	0		0.8	V
Input resistor, R _I	Gain ≤ 20 V/V (26 dB)	15			kΩ
Common mode input voltage range, V _{IC}	V _{DD} = 2.5 V, 5.5 V, CMRR ≤ -49 dB	0.5		V _{DD} -0.8	V
Operating free-air temperature, T _A		-40		85	°C

PACKAGE DISSIPATION RATINGS

PACKAGE	DERATING FACTOR	T _A ≤ 25°C POWER RATING	T _A = 70°C POWER RATING	T _A = 85°C POWER RATING
GQY	16 mW/°C	2 W	1.28 W	1.04 W
DRB	21.8 mW/°C	2.7 W	1.7 W	1.4 W

ELECTRICAL CHARACTERISTICS
 $T_A = 25^\circ\text{C}$ (unless otherwise noted)

PARAMETER		TEST CONDITIONS	MIN	TYP	MAX	UNIT
$ V_{OS} $	Output offset voltage (measured differentially)	$V_I = 0\text{ V}$, $A_V = 2\text{ V/V}$, $V_{DD} = 2.5\text{ V to }5.5\text{ V}$			25	mV
PSRR	Power supply rejection ratio	$V_{DD} = 2.5\text{ V to }5.5\text{ V}$		-75	-55	dB
CMRR	Common mode rejection ratio	$V_{DD} = 2.5\text{ V to }5.5\text{ V}$, $V_{IC} = V_{DD}/2\text{ to }0.5\text{ V}$ $V_{IC} = V_{DD}/2\text{ to }V_{DD} - 0.8\text{ V}$		-68	-49	dB
$ I_{IH} $	High-level input current	$V_{DD} = 5.5\text{ V}$, $V_I = 5.8\text{ V}$			50	μA
$ I_{IL} $	Low-level input current	$V_{DD} = 5.5\text{ V}$, $V_I = 0.3\text{ V}$			1	μA
$I_{(Q)}$	Quiescent current	$V_{DD} = 5.5\text{ V}$, no load		3.4	4.5	mA
		$V_{DD} = 3.6\text{ V}$, no load		2.8		
		$V_{DD} = 2.5\text{ V}$, no load		2.2	3.2	
$I_{(SD)}$	Shutdown current	$V_{(SHUTDOWN)} = 0.8\text{ V}$, $V_{DD} = 2.5\text{ V to }5.5\text{ V}$		0.5	2	μA
$r_{DS(on)}$	Static drain-source on-state resistance	$V_{DD} = 2.5\text{ V}$		770		m Ω
		$V_{DD} = 3.6\text{ V}$		590		
		$V_{DD} = 5.5\text{ V}$		500		
	Output impedance in SHUTDOWN	$V_{(SHUTDOWN)} = 0.8\text{ V}$		>1		k Ω
$f_{(sw)}$	Switching frequency	$V_{DD} = 2.5\text{ V to }5.5\text{ V}$	200	250	300	kHz
	Gain		$\frac{285\text{ k}\Omega}{R_I}$	$\frac{300\text{ k}\Omega}{R_I}$	$\frac{315\text{ k}\Omega}{R_I}$	$\frac{\text{V}}{\text{V}}$

OPERATING CHARACTERISTICS
 $T_A = 25^\circ\text{C}$, Gain = 2 V/V, $R_L = 8\ \Omega$ (unless otherwise noted)

PARAMETER		TEST CONDITIONS		MIN	TYP	MAX	UNIT
P_O	Output power	THD + N = 1%, $f = 1\text{ kHz}$, $R_L = 8\ \Omega$	$V_{DD} = 5\text{ V}$		1.18		W
			$V_{DD} = 3.6\text{ V}$		0.58		
			$V_{DD} = 2.5\text{ V}$		0.26		
THD+N	Total harmonic distortion plus noise		$V_{DD} = 5\text{ V}$, $P_O = 1\text{ W}$, $R_L = 8\ \Omega$, $f = 1\text{ kHz}$		0.18%		
			$V_{DD} = 3.6\text{ V}$, $P_O = 0.5\text{ W}$, $R_L = 8\ \Omega$, $f = 1\text{ kHz}$		0.19%		
			$V_{DD} = 2.5\text{ V}$, $P_O = 200\text{ mW}$, $R_L = 8\ \Omega$, $f = 1\text{ kHz}$		0.20%		
k_{SVR}	Supply ripple rejection ratio	$V_{DD} = 3.6\text{ V}$, Inputs ac-grounded with $C_i = 2\ \mu\text{F}$	$f = 217\text{ Hz}$, $V_{(RIPPLE)} = 200\text{ mV}_{pp}$		-71		dB
SNR	Signal-to-noise ratio	$V_{DD} = 5\text{ V}$, $P_O = 1\text{ W}$, $R_L = 8\ \Omega$			97		dB
V_n	Output voltage noise	$V_{DD} = 3.6\text{ V}$, $f = 20\text{ Hz to }20\text{ kHz}$, Inputs ac-grounded with $C_i = 2\ \mu\text{F}$	No weighting		48		μV_{RMS}
			A weighting		36		
CMRR	Common mode rejection ratio	$V_{DD} = 3.6\text{ V}$ $V_{IC} = 1\text{ V}_{pp}$	$f = 217\text{ Hz}$		-63		dB
Z_I	Input impedance			142	150	158	k Ω
	Start-up time from shutdown	$V_{DD} = 3.6\text{ V}$			9		ms

TPA2005D1

SLOS369B – JULY 2002 – REVISED DECEMBER 2002

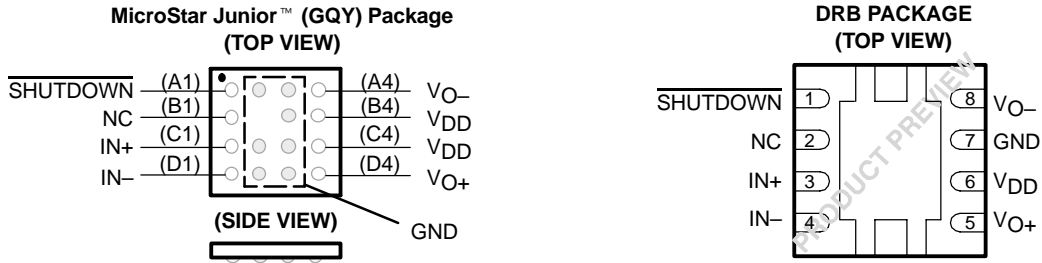

NC – No internal connection

NOTES:A. The shaded terminals are used for electrical and thermal connections to the ground plane. All the shaded terminals need to be electrical connected to ground. No connect (NC) terminals still need a pad and trace.

B. The thermal pad of the DRB package should be electrically and thermally connected to a ground plane.

TERMINAL FUNCTIONS

TERMINAL			I/O	DESCRIPTION
NAME	GQY	DRB		
IN-	D1	4	I	Negative differential input
IN+	C1	3	I	Positive differential input
VDD	B4, C4	6	I	Power supply
VO+	D4	5	O	Positive BTL output
GND	A2, A3, B3, C2, C3, D2, D3	7	I	High-current ground
VO-	A4	8	O	Negative BTL output
SHUTDOWN	A1	1	I	Shutdown terminal (active low logic)
NC	B1	2		No connect

FUNCTIONAL BLOCK DIAGRAM

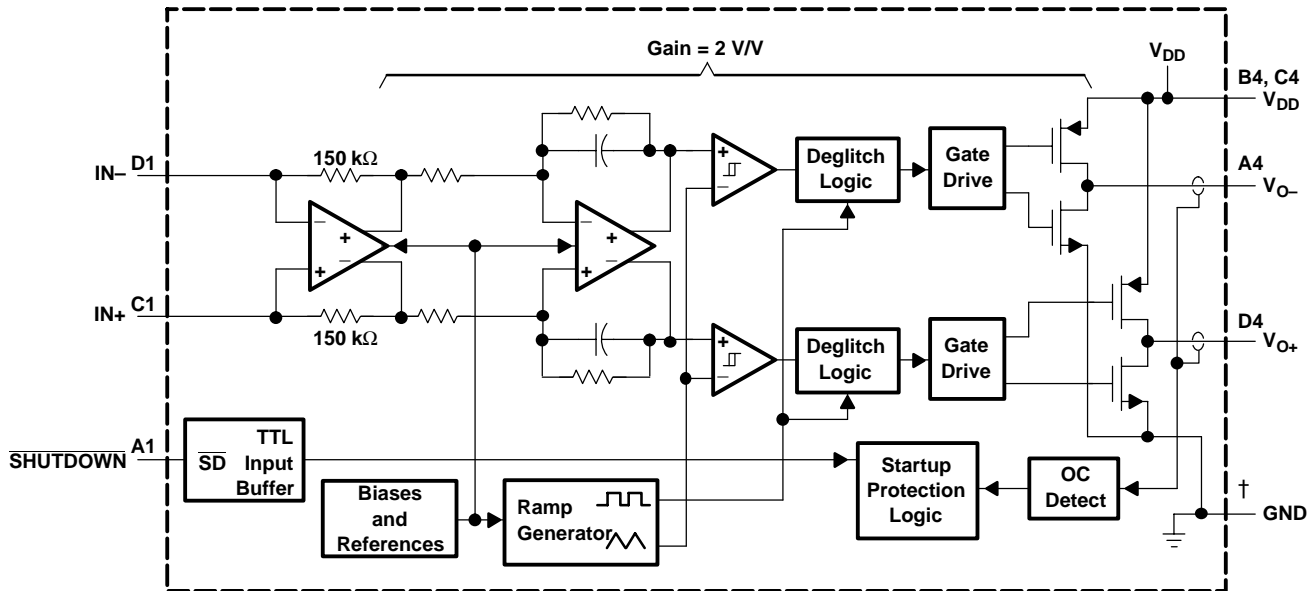

† A2, A3, B3, C2, C3, D2, D3

TYPICAL CHARACTERISTICS

TABLE OF GRAPHS

		FIGURE	
Efficiency		vs Output power	1, 2
P_D	Power dissipation	vs Output power	3
	Supply current	vs Output power	4, 5
$I_{(Q)}$	Quiescent current	vs Supply voltage	6
$I_{(SD)}$	Shutdown current	vs Shutdown voltage	7
P_O	Output power	vs Supply voltage	8
		vs Load resistance	9, 10
THD+N	Total harmonic distortion plus noise	vs Output power	11, 12
		vs Frequency	13, 14, 15, 16
		vs Common-mode input voltage	17
K_{SVR}	Supply voltage rejection ratio	vs Frequency	18, 19, 20
		vs Common-mode input voltage	21
	GSM power supply rejection	vs Time	22
		vs Frequency	23
CMRR	Common-mode rejection ratio	vs Frequency	24
		vs Common-mode input voltage	25

TEST SET-UP FOR GRAPHS

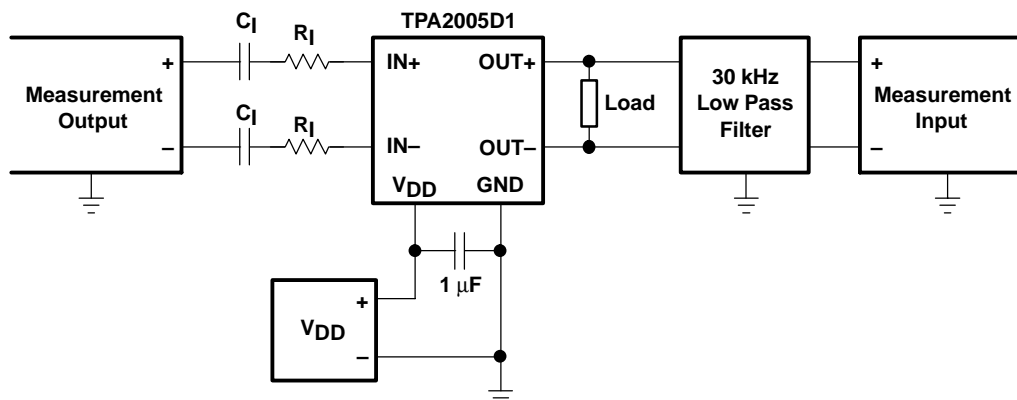

Notes:

- (1) C_1 was Shorted for any Common-Mode input voltage measurement
- (2) A 33- μ H inductor was placed in series with the load resistor to emulate a small speaker for efficiency measurements.
- (3) The 30-kHz low-pass filter is required even if the analyzer has a low-pass filter. An RC filter (100 Ω , 47 nF) is used on each output for the data sheet graphs.

TYPICAL CHARACTERISTICS

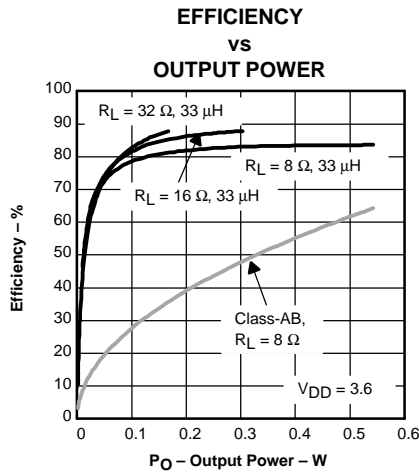

Figure 1

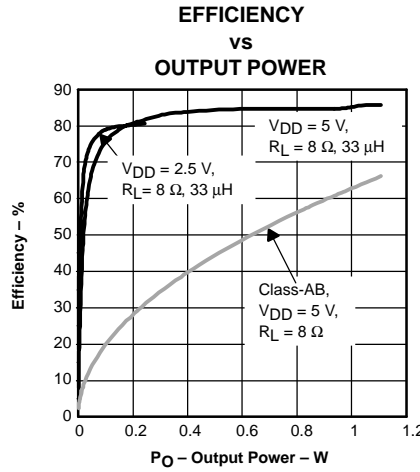

Figure 2

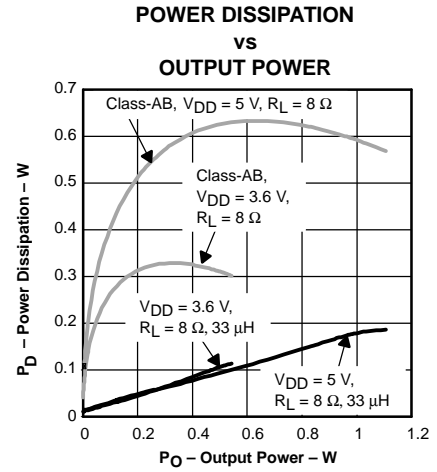

Figure 3

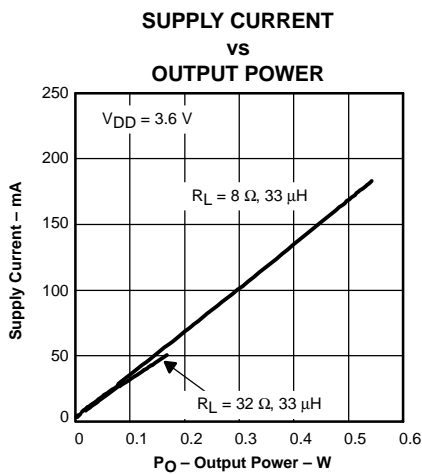

Figure 4

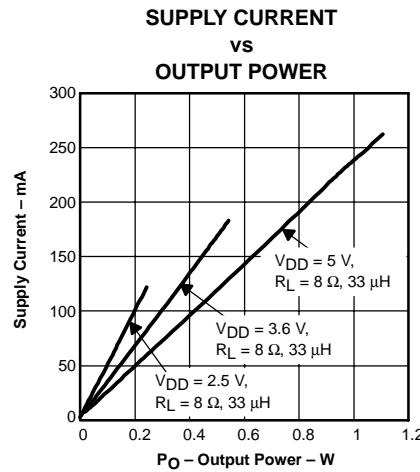

Figure 5

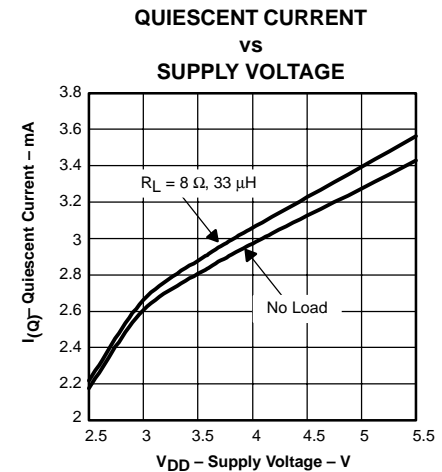

Figure 6

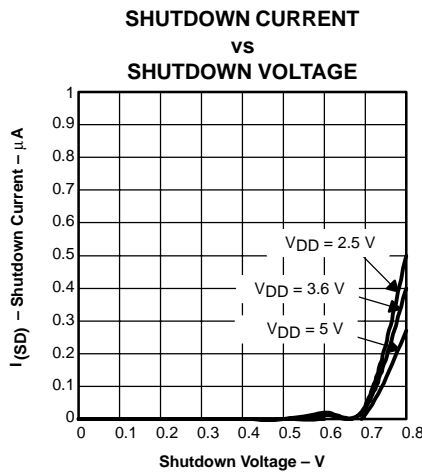

Figure 7

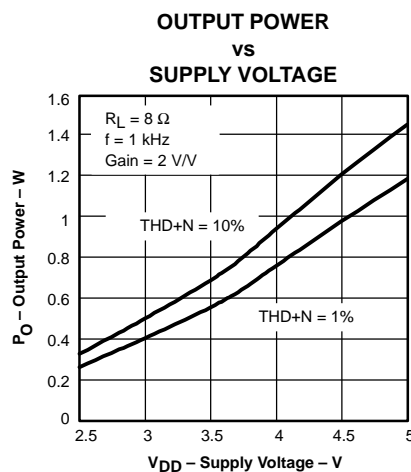

Figure 8

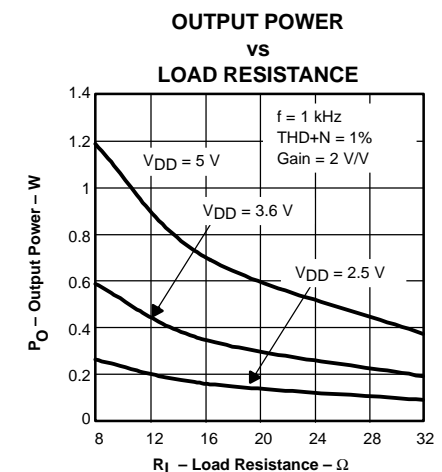

Figure 9

TYPICAL CHARACTERISTICS

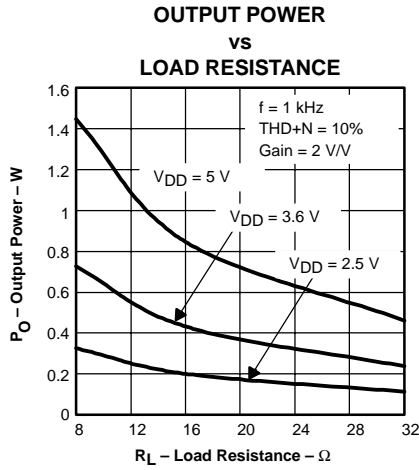

Figure 10

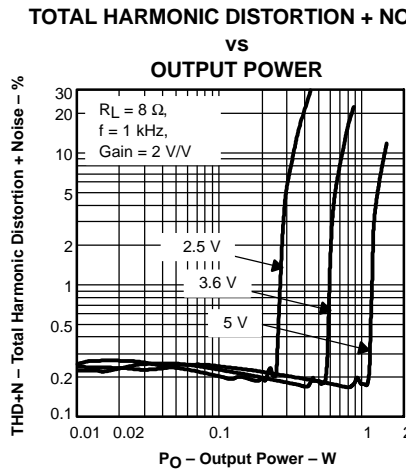

Figure 11

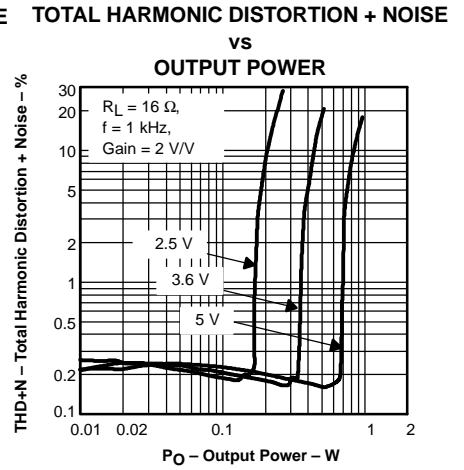

Figure 12

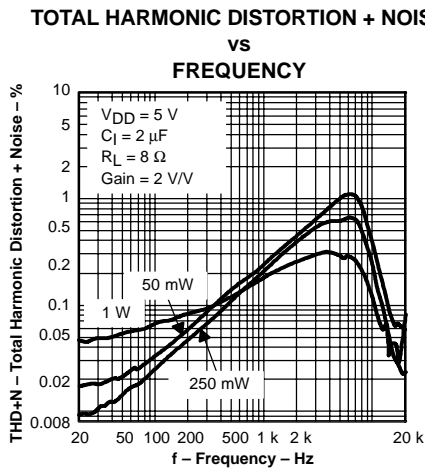

Figure 13

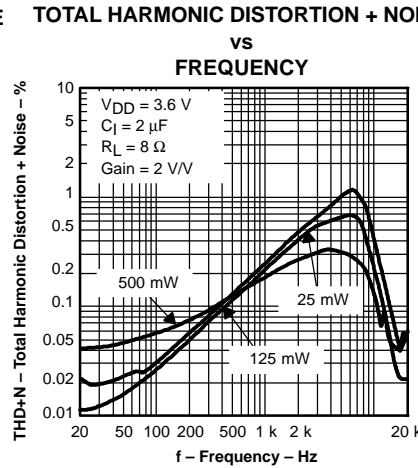

Figure 14

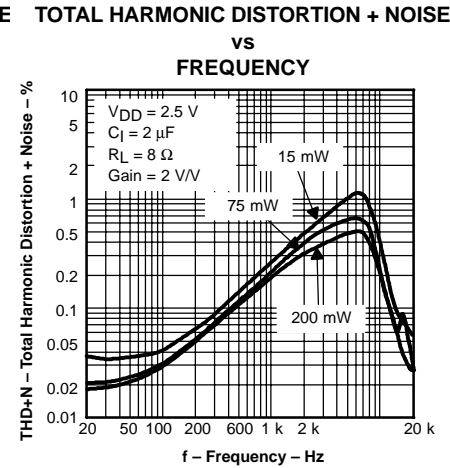

Figure 15

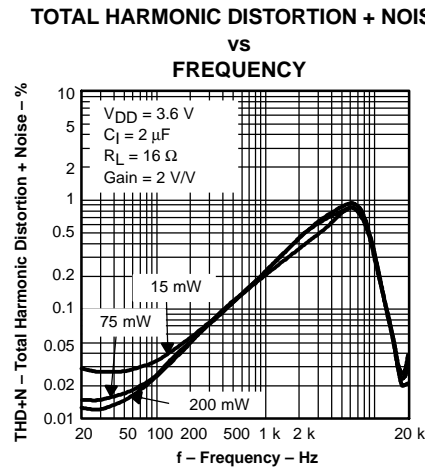

Figure 16

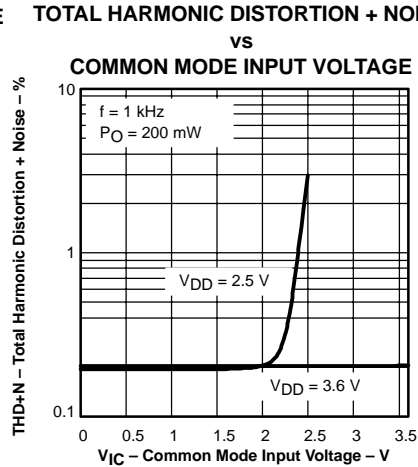

Figure 17

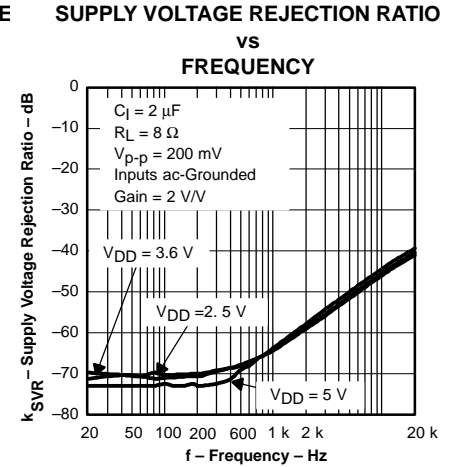

Figure 18

TYPICAL CHARACTERISTICS

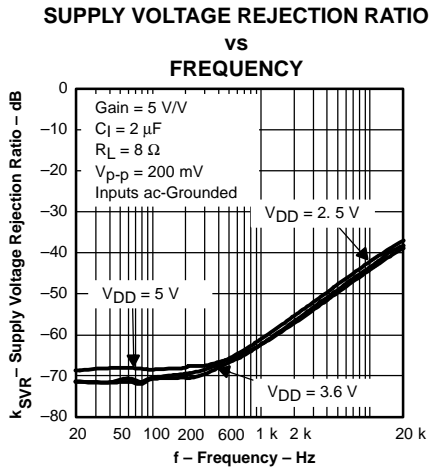

Figure 19

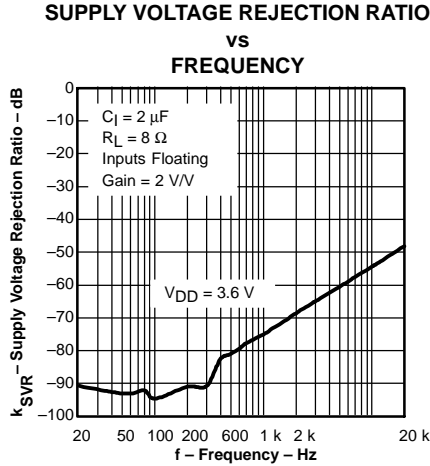

Figure 20

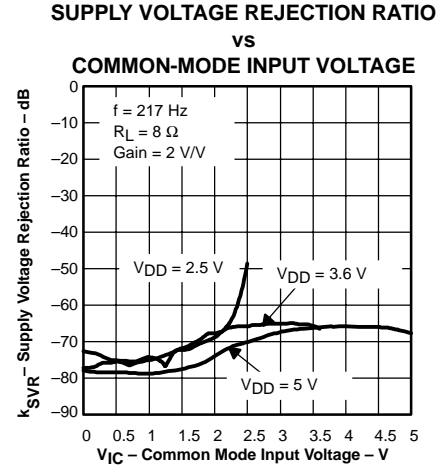

Figure 21

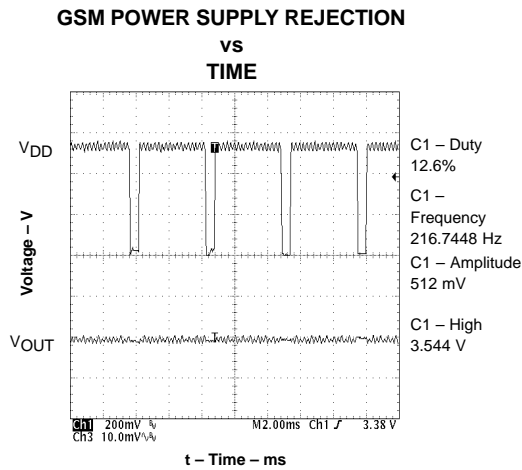

Figure 22

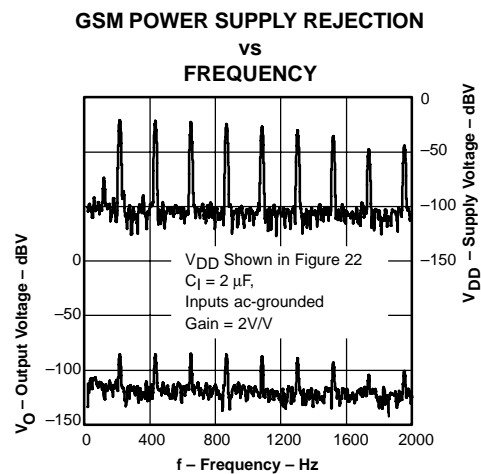

Figure 23

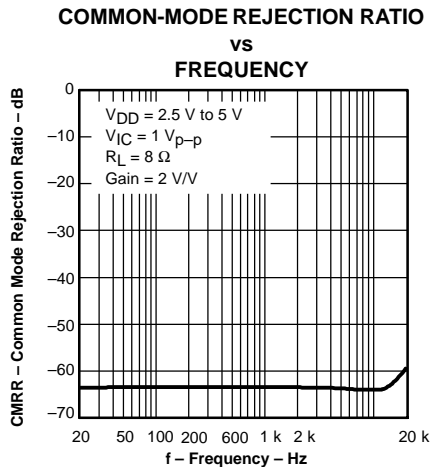

Figure 24

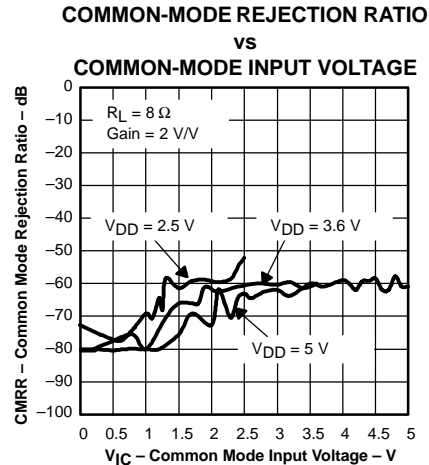

Figure 25

APPLICATION INFORMATION

FULLY DIFFERENTIAL AMPLIFIER

The TPA2005D1 is a fully differential amplifier with differential inputs and outputs. The fully differential amplifier consists of a differential amplifier and a common-mode amplifier. The differential amplifier ensures that the amplifier outputs a differential voltage on the output that is equal to the differential input times the gain. The common-mode feedback ensures that the common-mode voltage at the output is biased around $V_{DD}/2$ regardless of the common-mode voltage at the input. The fully differential TPA2005D1 can still be used with a single-ended input; however, the TPA2005D1 should be used with differential inputs when in a noisy environment, like a wireless handset, to ensure maximum noise rejection.

Advantages of Fully Differential Amplifiers

- Input-coupling capacitors not required:
 - The fully differential amplifier allows the inputs to be biased at voltage other than mid-supply. For example, if a codec has a midsupply lower than the midsupply of the TPA2005D1, the common-mode feedback circuit will adjust, and the TPA2005D1 outputs will still be biased at midsupply of the TPA2005D1. The inputs of the TPA2005D1 can be biased from 0.5V to $V_{DD} - 0.8$ V. If the inputs are biased outside of that range, input-coupling capacitors are required.
- Midsupply bypass capacitor, $C_{(BYPASS)}$, not required:
 - The fully differential amplifier does not require a bypass capacitor. This is because any shift in the midsupply affects both positive and negative channels equally and cancels at the differential output.
- Better RF-immunity:
 - GSM handsets save power by turning on and shutting off the RF transmitter at a rate of 217 Hz. The transmitted signal is picked-up on input and output traces. The fully differential amplifier cancels the signal much better than the typical audio amplifier.

COMPONENT SELECTION

Figure 26 shows the TPA2005D1 typical schematic with differential inputs and Figure 27 shows the TPA2005D1 with differential inputs and input capacitors, and Figure 28 shows the TPA2005D1 with single-ended inputs. Differential inputs should be used whenever possible because the single-ended inputs are much more susceptible to noise.

Table 1. Typical Component Values

REF DES	VALUE	EIA SIZE	MANUFACTURER	PART NUMBER
R_I	150 k Ω ($\pm 0.5\%$)	0402	Panasonic	ERJ2RHD154V
C_S	1 μ F (+22%, -80%)	0402	Murata	GRP155F50J105Z
$C_I(1)$	3.3 nF ($\pm 10\%$)	0201	Murata	GRP033B10J332K

(1) C_I is only needed for single-ended input or if V_{ICM} is not between 0.5 V and $V_{DD} - 0.8$ V. $C_I = 3.3$ nF (with $R_I = 150$ k Ω) gives a high-pass corner frequency of 321 Hz.

TPA2005D1

SLOS369B – JULY 2002 – REVISED DECEMBER 2002

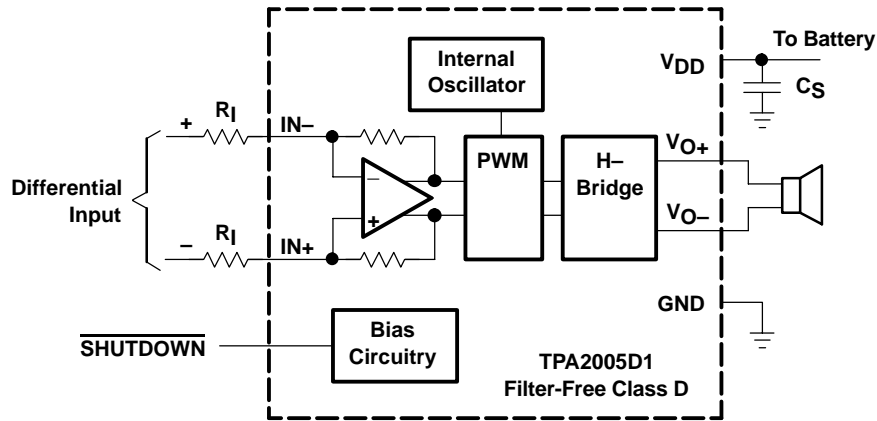

Figure 26. Typical TPA2005D1 Application Schematic With Differential Input for a Wireless Phone

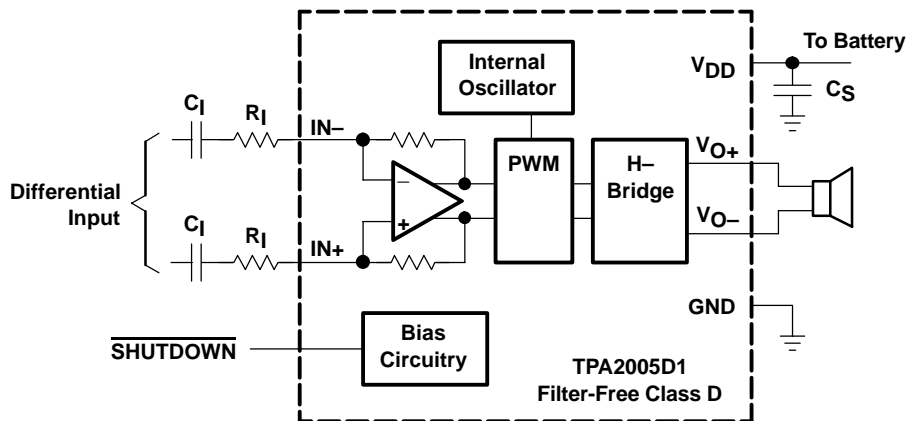

Figure 27. TPA2005D1 Application Schematic With Differential Input and Input Capacitors

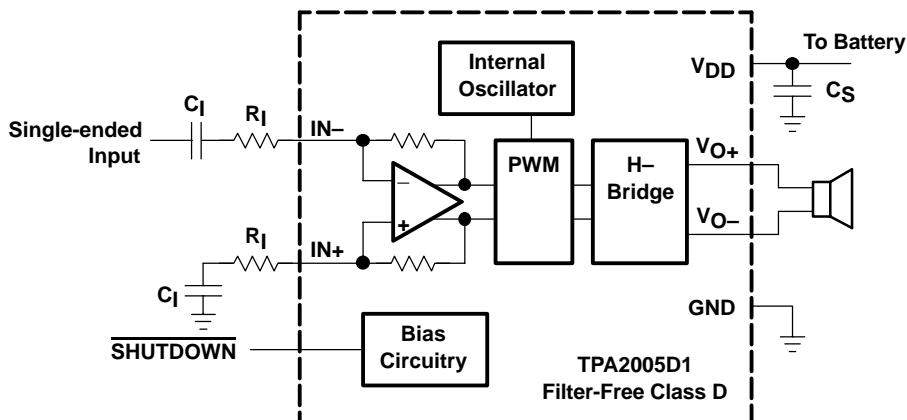

Figure 28. TPA2005D1 Application Schematic With Single-Ended Input

Input Resistors (R_I)

The input resistors (R_I) set the gain of the amplifier according to equation (1).

$$\text{Gain} = \frac{300 \text{ k}\Omega}{R_I} \left(\frac{\text{V}}{\text{V}} \right) \quad (1)$$

Resistor matching is very important in fully differential amplifiers. The balance of the output on the reference voltage depends on matched ratios of the resistors. CMRR, PSRR, and cancellation of the second harmonic distortion diminish if resistor mismatch occurs. Therefore, it is recommended to use 1% tolerance resistors or better to keep the performance optimized. Matching is more important than overall tolerance. Resistor arrays with 1% matching can be used with a tolerance greater than 1%.

Place the input resistors very close to the TPA2005D1 to limit noise injection on the high-impedance nodes.

For optimal performance the gain should be set to 2 V/V or lower. Lower gain allows the TPA2005D1 to operate at its best, and keeps a high voltage at the input making the inputs less susceptible to noise.

Decoupling Capacitor (C_S)

The TPA2005D1 is a high-performance class-D audio amplifier that requires adequate power supply decoupling to ensure the efficiency is high and total harmonic distortion (THD) is low. For higher frequency transients, spikes, or digital hash on the line, a good low equivalent-series-resistance (ESR) ceramic capacitor, typically 1 μF , placed as close as possible to the device V_{DD} lead works best. Placing this decoupling capacitor close to the TPA2005D1 is very important for the efficiency of the class-D amplifier, because any resistance or inductance in the trace between the device and the capacitor can cause a loss in efficiency. For filtering lower-frequency noise signals, a 10 μF or greater capacitor placed near the audio power amplifier would also help, but it is not required in most applications because of the high PSRR of this device.

Input Capacitors (C_I)

The TPA2005D1 does not require input coupling capacitors if the design uses a differential source that is biased from 0.5 V to $V_{DD} - 0.8$ V (shown in Figure 26). If the input signal is not biased within the recommended common-mode input range, if needing to use the input as a high pass filter (shown in Figure 27), or if using a single-ended source (shown in Figure 28), input coupling capacitors are required.

The input capacitors and input resistors form a high-pass filter with the corner frequency, f_c , determined in equation (2).

$$f_c = \frac{1}{(2\pi R_I C_I)} \quad (2)$$

The value of the input capacitor is important to consider as it directly affects the bass (low frequency) performance of the circuit. Speakers in wireless phones cannot usually respond well to low frequencies, so the corner frequency can be set to block low frequencies in this application.

Equation (3) is reconfigured to solve for the input coupling capacitance.

$$C_I = \frac{1}{(2\pi R_I f_c)} \quad (3)$$

If the corner frequency is within the audio band, the capacitors should have a tolerance of $\pm 10\%$ or better, because any mismatch in capacitance causes an impedance mismatch at the corner frequency and below.

For a flat low-frequency response, use large input coupling capacitors (1 μF). However, in a GSM phone the ground signal is fluctuating at 217 Hz, but the signal from the codec does not have the same 217 Hz fluctuation. The difference between the two signals is amplified, sent to the speaker, and heard as a 217 Hz hum.

TPA2005D1

SLOS369B – JULY 2002 – REVISED DECEMBER 2002

SUMMING INPUT SIGNALS WITH THE TPA2005D1

Most wireless phones or PDAs need to sum signals at the audio power amplifier or just have two signal sources that need separate gain. The TPA2005D1 makes it easy to sum signals or use separate signal sources with different gains. Many phones now use the same speaker for the earpiece and ringer, where the wireless phone would require a much lower gain for the phone earpiece than for the ringer. PDAs and phones that have stereo headphones require summing of the right and left channels to output the stereo signal to the mono speaker.

Summing Two Differential Input Signals

Two extra resistors are needed for summing differential signals (a total of 5 components). The gain for each input source can be set independently (see equations (4) and (5), and Figure 29).

$$\text{Gain 1} = \frac{V_O}{V_{I1}} = \frac{300 \text{ k}\Omega}{R_{I1}} \left(\frac{V}{V} \right) \quad (4)$$

$$\text{Gain 2} = \frac{V_O}{V_{I2}} = \frac{300 \text{ k}\Omega}{R_{I2}} \left(\frac{V}{V} \right) \quad (5)$$

If summing left and right inputs with a gain of 1 V/V, use $R_{I1} = R_{I2} = 300 \text{ k}\Omega$.

If summing a ring tone and a phone signal, set the ring-tone gain to Gain 2 = 2 V/V, and the phone gain to gain 1 = 0.1 V/V. The resistor values would be . . .

$R_{I1} = 3 \text{ M}\Omega$, and $R_{I2} = 150 \text{ k}\Omega$.

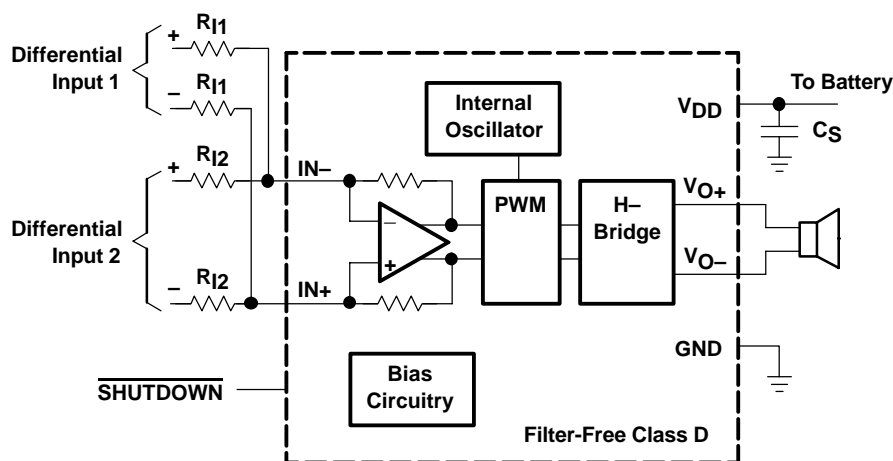

Figure 29. Application Schematic With TPA2005D1 Summing Two Differential Inputs

Summing a Differential Input Signal and a Single-Ended Input Signal

Figure 30 shows how to sum a differential input signal and a single-ended input signal. Ground noise can couple in through IN+ with this method. It is better to use differential inputs. The corner frequency of the single-ended input is set by C_{I2}, shown in equation (8). To assure that each input is balanced, the single-ended input must be driven by a low-impedance source even if the input is not in use

$$\text{Gain 1} = \frac{V_O}{V_{I1}} = \frac{300 \text{ k}\Omega}{R_{I1}} \left(\frac{V}{V} \right) \tag{6}$$

$$\text{Gain 2} = \frac{V_O}{V_{I2}} = \frac{300 \text{ k}\Omega}{R_{I2}} \left(\frac{V}{V} \right) \tag{7}$$

$$C_{I2} = \frac{1}{(2\pi R_{I2} f_{c2})} \tag{8}$$

If summing a ring tone and a phone signal, the phone signal should use a differential input signal while the ring tone might be limited to a single-ended signal. Phone gain is set at gain 1 = 0.1 V/V, and the ring-tone gain is set to gain 2 = 2 V/V, the resistor values would be...

R_{I1} = 3 MΩ, and = R_{I2} = 150 kΩ.

The high paMs corner frequency of the single-ended input is set by C_{I2}. If the desired corner frequency is less than 20 Hz...

$$C_{I2} > \frac{1}{(2\pi 150\text{k}\Omega 20\text{Hz})}$$

$$C_{I2} > 53\text{pF}$$

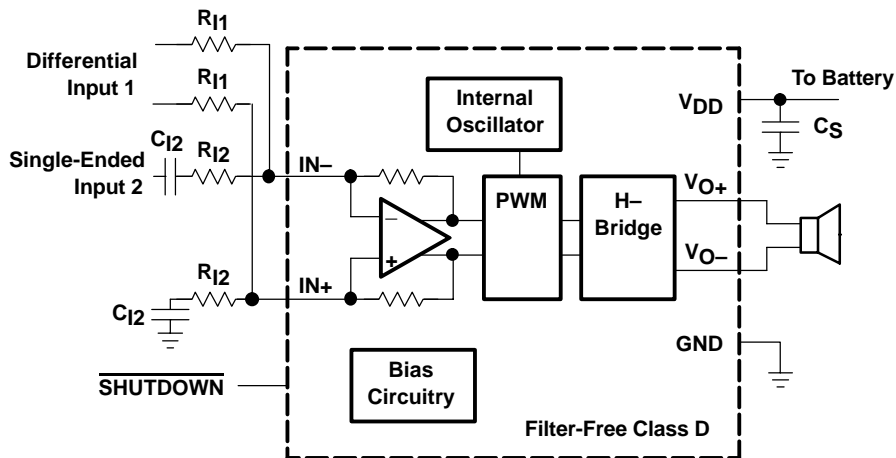

Figure 30. Application Schematic With TPA2005D1 Summing Differential Input and Single-Ended Input Signals

TPA2005D1

SLOS369B – JULY 2002 – REVISED DECEMBER 2002

Summing Two Single-Ended Input Signals

Four resistors and three capacitors are needed for summing single-ended input signals. The gain and corner frequencies (f_{c1} and f_{c2}) for each input source can be set independently (see equations (9) through (12), and Figure 31). Resistor, R_P , and capacitor, C_P , are needed on the IN+ terminal to match the impedance on the IN– terminal. The single-ended inputs must be driven by low impedance sources even if one of the inputs is not outputting an ac signal.

$$\text{Gain 1} = \frac{V_O}{V_{I1}} = \frac{300 \text{ k}\Omega}{R_{I1}} \left(\frac{V}{V} \right) \quad (9)$$

$$\text{Gain 2} = \frac{V_O}{V_{I2}} = \frac{300 \text{ k}\Omega}{R_{I2}} \left(\frac{V}{V} \right) \quad (10)$$

$$C_{I1} = \frac{1}{(2\pi R_{I1} f_{c1})} \quad (11)$$

$$C_{I2} = \frac{1}{(2\pi R_{I2} f_{c2})} \quad (12)$$

$$C_P = C_{I1} + C_{I2} \quad (13)$$

$$R_P = \frac{R_{I1} \times R_{I2}}{(R_{I1} + R_{I2})} \quad (14)$$

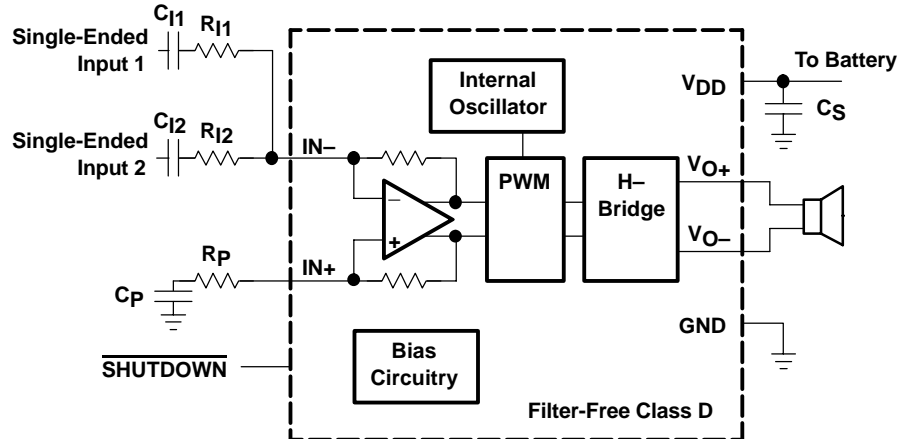

Figure 31. Application Schematic With TPA2005D1 Summing Two Single-Ended Inputs

EFFICIENCY AND THERMAL INFORMATION

The maximum ambient temperature depends on the heat-sinking ability of the PCB system. The derating factor for the 2.5-mm x 2.5-mm MicroStar Junior package is shown in the dissipation rating table. Converting this to θ_{JA} :

$$\theta_{JA} = \frac{1}{\text{Derating Factor}} = \frac{1}{0.016} = 62.5^{\circ}\text{C/W} \quad (15)$$

Given θ_{JA} of 62.5°C/W, the maximum allowable junction temperature of 150°C, and the maximum internal dissipation of 0.2 W (worst case 5-V supply), the maximum ambient temperature can be calculated with the following equation.

$$T_{A\text{Max}} = T_{J\text{Max}} - \theta_{JA} P_{D\text{max}} = 150 - 62.5 (0.2) = 137.5^{\circ}\text{C} \quad (16)$$

Equation (16) shows that the calculated maximum ambient temperature is 137.5°C at maximum power dissipation with a 5-V supply; however, the maximum ambient temperature of the package is limited to 85°C. Because of the efficiency of the TPA2005D1, it can be operated under all conditions to an ambient temperature of 85°C. The TPA2005D1 is designed with thermal protection that turns the device off when the junction temperature surpasses 150°C to prevent damage to the IC. Also, using speakers more resistive than 8-Ω dramatically increases the thermal performance by reducing the output current and increasing the efficiency of the amplifier.

BOARD LAYOUT

Component Location

Place all the external components very close to the TPA2005D1. The input resistors need to be very close to the TPA2005D1 input pins so noise does not couple on the high impedance nodes between the input resistors and the input amplifier of the TPA2005D1. Placing the decoupling capacitor, C_S , close to the TPA2005D1 is important for the efficiency of the class-D amplifier. Any resistance or inductance in the trace between the device and the capacitor can cause a loss in efficiency.

Trace Width

Make the high current traces going to pins VDD, GND, V_{O+} and V_{O-} of the TPA2005D1 have a minimum width of 0.7 mm. If these traces are too thin, the TPA2005D1's performance and output power will decrease. The input traces do not need to be wide, but do need to run side-by-side to enable common-mode noise cancellation.

TPA2005D1

SLOS369B – JULY 2002 – REVISED DECEMBER 2002

MicroStar Junior™ BGA Layout

Use the following MicroStar Junior BGA ball diameters:

- 0.25 mm diameter solder mask
- 0.28 mm diameter solder paste mask/stencil
- 0.38 mm diameter copper trace

Figure 7 shows how to lay out a board for the TPA2005D1 MicroStar Junior BGA.

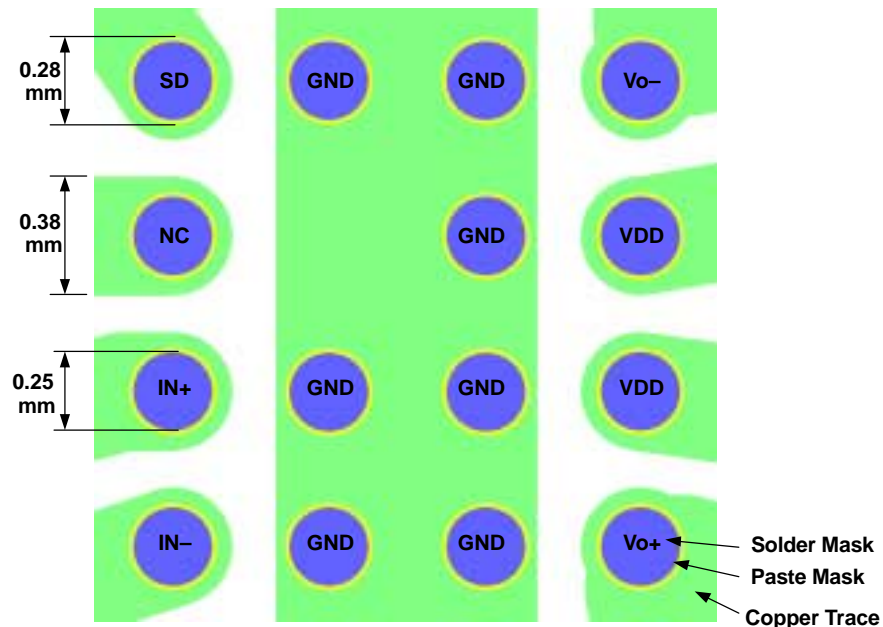

Figure 32. TPA2005D1 MicroStar Junior BGA Board Layout (Top View)

ELIMINATING THE OUTPUT FILTER WITH THE TPA2005D1

This section focuses on why the user can eliminate the output filter with the TPA2005D1.

Effect on Audio

The class-D amplifier outputs a pulse-width modulated (PWM) square wave, which is the sum of the switching waveform and the amplified input audio signal. The human ear acts as a band-pass filter such that only the frequencies between approximately 20 Hz and 20 kHz are passed. The switching frequency components are much greater than 20 kHz, so the only signal heard is the amplified input audio signal.

Traditional Class-D Modulation Scheme

The traditional class-D modulation scheme, which is used in the TPA005Dxx family, has a differential output where each output is 180 degrees out of phase and changes from ground to the supply voltage, V_{DD} . Therefore, the differential pre-filtered output varies between positive and negative V_{DD} , where filtered 50% duty cycle yields 0 volts across the load. The traditional class-D modulation scheme with voltage and current waveforms is shown in Figure 33. Note that even at an average of 0 volts across the load (50% duty cycle), the current to the load is high causing a high loss and thus causing a high supply current.

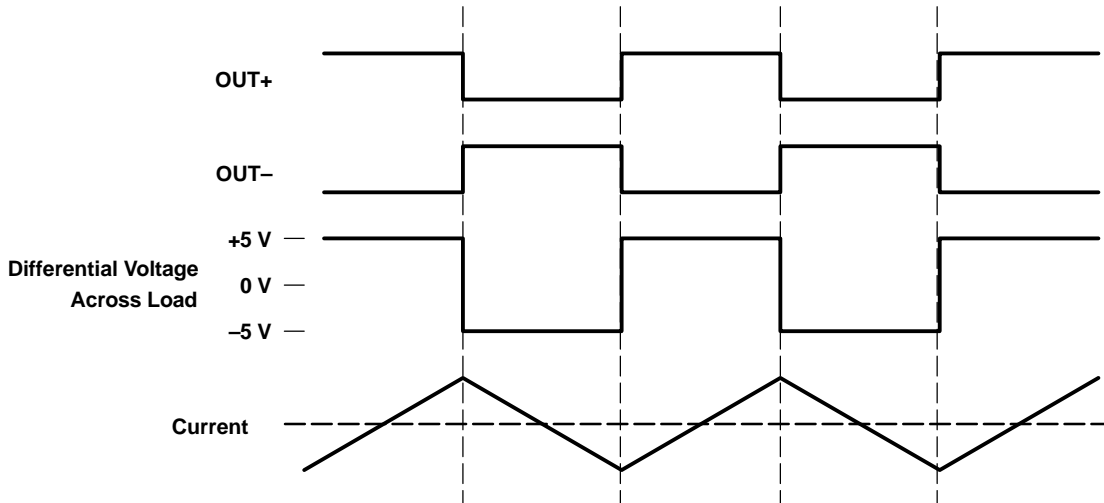

Figure 33. Traditional Class-D Modulation Scheme's Output Voltage and Current Waveforms Into an Inductive Load With no Input

TPA2005D1 Modulation Scheme

The TPA2005D1 uses a modulation scheme that still has each output switching from 0 to the supply voltage. However, OUT+ and OUT- are now in phase with each other with no input. The duty cycle of OUT+ is greater than 50% and OUT- is less than 50% for positive voltages. The duty cycle of OUT+ is less than 50% and OUT- is greater than 50% for negative voltages. The voltage across the load sits at 0 volts throughout most of the switching period greatly reducing the switching current, which reduces any I^2R losses in the load.

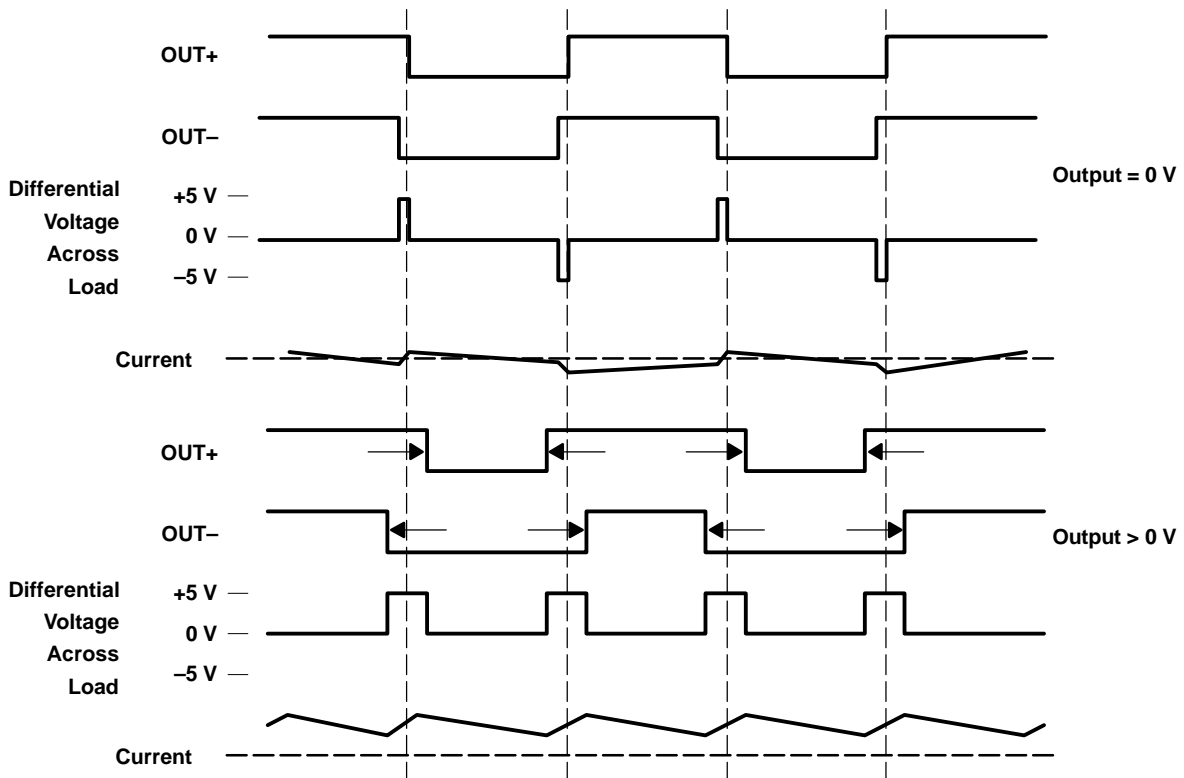

Figure 34. The TPA2005D1 Output Voltage and Current Waveforms Into an Inductive Load

Efficiency: Why You Must Use a Filter With the Traditional Class-D Modulation Scheme

The main reason that the traditional class-D amplifier needs an output filter is that the switching waveform results in maximum current flow. This causes more loss in the load, which causes lower efficiency. The ripple current is large for the traditional modulation scheme because the ripple current is proportional to voltage multiplied by the time at that voltage. The differential voltage swing is $2 \times V_{DD}$ and the time at each voltage is half the period for the traditional modulation scheme. An ideal LC filter is needed to store the ripple current from each half cycle for the next half cycle, while any resistance causes power dissipation. The speaker is both resistive and reactive, whereas an LC filter is almost purely reactive.

The TPA2005D1 modulation scheme has very little loss in the load without a filter because the pulses are very short and the change in voltage is V_{DD} instead of $2 \times V_{DD}$. As the output power increases, the pulses widen making the ripple current larger. Ripple current could be filtered with an LC filter for increased efficiency, but for most applications the filter is not needed.

An LC filter with a cutoff frequency less than the class-D switching frequency allows the switching current to flow through the filter instead of the load. The filter has less resistance than the speaker that results in less power dissipated, which increases efficiency.

Effects of Applying a Square Wave Into a Speaker

If the amplitude of a square wave is high enough and the frequency of the square wave is within the bandwidth of the speaker, a square wave could cause the voice coil to jump out of the air gap and/or scar the voice coil. A 250-kHz switching frequency, however, is not significant because the speaker cone movement is proportional to $1/f^2$ for frequencies beyond the audio band. Therefore, the amount of cone movement at the switching frequency is very small. However, damage could occur to the speaker if the voice coil is not designed to handle the additional power. To size the speaker for added power, the ripple current dissipated in the load needs to be calculated by subtracting the theoretical supplied power, $P_{SUP\ THEORETICAL}$, from the actual supply power, P_{SUP} , at maximum output power, P_{OUT} . The switching power dissipated in the speaker is the inverse of the measured efficiency, $\eta_{MEASURED}$, minus the theoretical efficiency, $\eta_{THEORETICAL}$.

$$P_{SPKR} = P_{SUP} - P_{SUP\ THEORETICAL} \quad (\text{at max output power}) \quad (17)$$

$$P_{SPKR} = \frac{P_{SUP}}{P_{OUT}} - \frac{P_{SUP\ THEORETICAL}}{P_{OUT}} \quad (\text{at max output power}) \quad (18)$$

$$P_{SPKR} = P_{OUT} \left(\frac{1}{\eta_{MEASURED}} - \frac{1}{\eta_{THEORETICAL}} \right) \quad (\text{at max output power}) \quad (19)$$

$$\eta_{THEORETICAL} = \frac{R_L}{R_L + 2r_{DS(on)}} \quad (\text{at max output power}) \quad (20)$$

The maximum efficiency of the TPA2005D1 with a 3.6 V supply and an 8- Ω load is 86% from equation (20). Using equation (19) with the efficiency at maximum power (84%), we see that there is an additional 17 mW dissipated in the speaker. The added power dissipated in the speaker is not an issue as long as it is taken into account when choosing the speaker.

When to Use an Output Filter

Design the TPA2005D1 without an output filter if the traces from amplifier to speaker are short. The TPA2005D1 passed FCC and CE radiated emissions with no shielding with speaker trace wires 100 mm long or less. Wireless handsets and PDAs are great applications for class-D without a filter.

A ferrite bead filter can often be used if the design is failing radiated emissions without an LC filter, and the frequency sensitive circuit is greater than 1 MHz. This is good for circuits that just have to pass FCC and CE because FCC and CE only test radiated emissions greater than 30 MHz. If choosing a ferrite bead, choose one with high impedance at high frequencies, but very low impedance at low frequencies.

Use an LC output filter if there are low frequency (< 1 MHz) EMI sensitive circuits and/or there are long leads from amplifier to speaker.

Figure 35 and Figure 36 show typical ferrite bead and LC output filters.

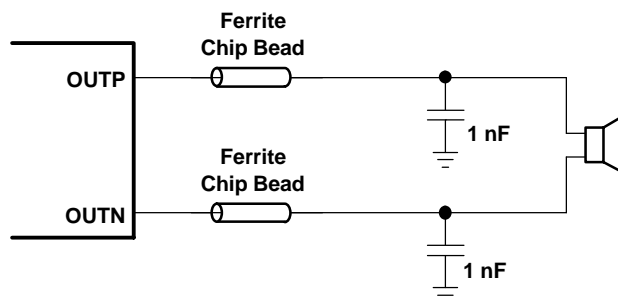

Figure 35. Typical Ferrite Chip Bead Filter (Chip bead example: NEC/Tokin: N2012ZPS121)

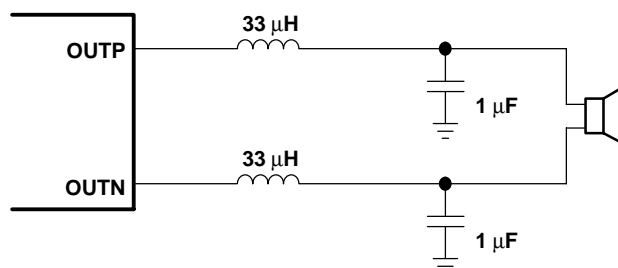

Figure 36. Typical LC Output Filter, Cutoff Frequency of 27 kHz

TPA2005D1

SLOS369B – JULY 2002 – REVISED DECEMBER 2002

MECHANICAL DATA

DRB (S-PDSO-N8)

PLASTIC SMALL OUTLINE

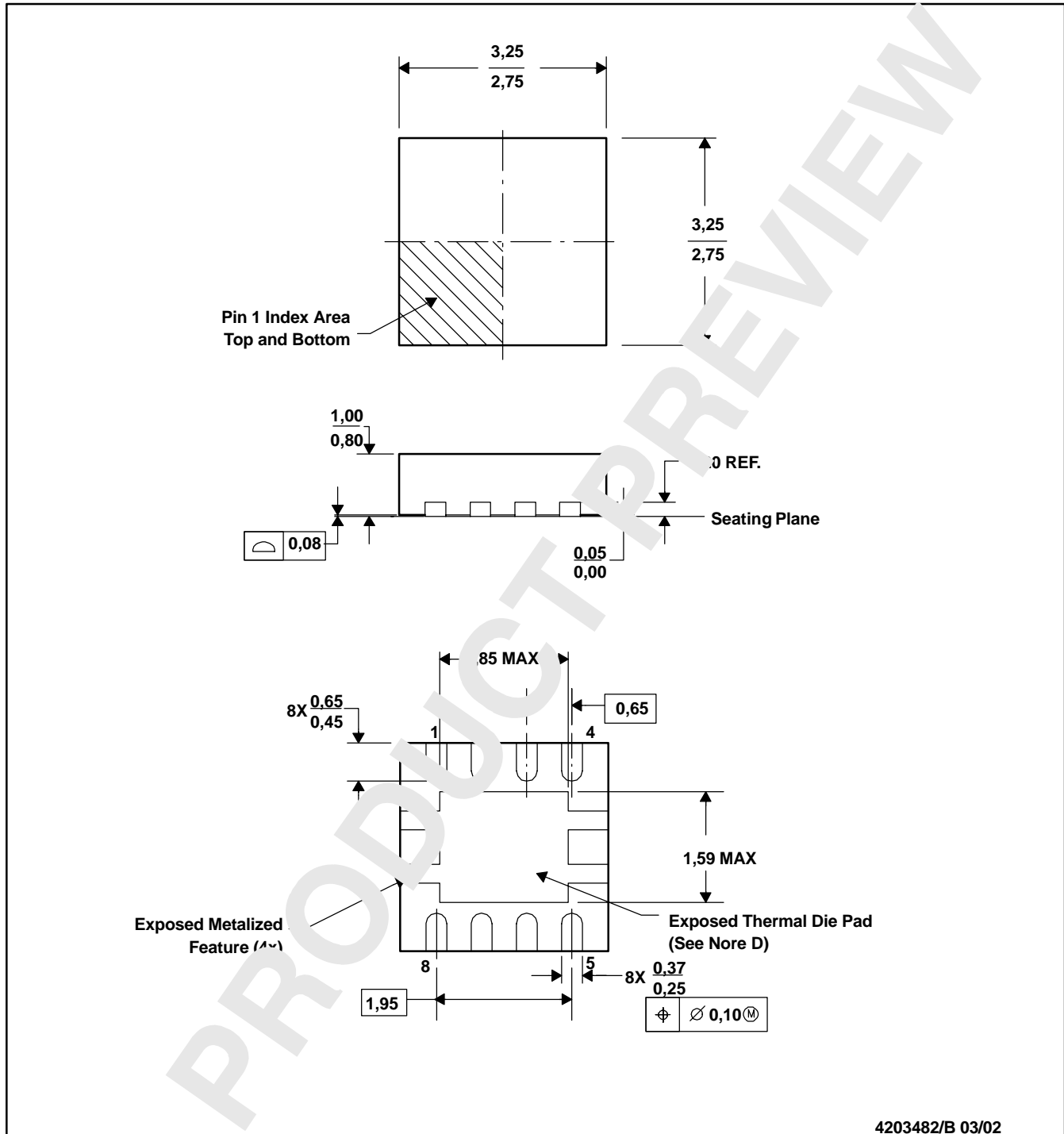

4203482/B 03/02

- NOTES: A. All linear dimensions are in millimeters.
 B. This drawing is subject to change without notice.
 C. Small Outline No-lead (SON) package configuration.
 D. The package thermal performance may be enhanced by bonding the thermal die pad to an external thermal plane.

MECHANICAL DATA

GQY (S-PBGA-N15)

PLASTIC BALL GRID ARRAY

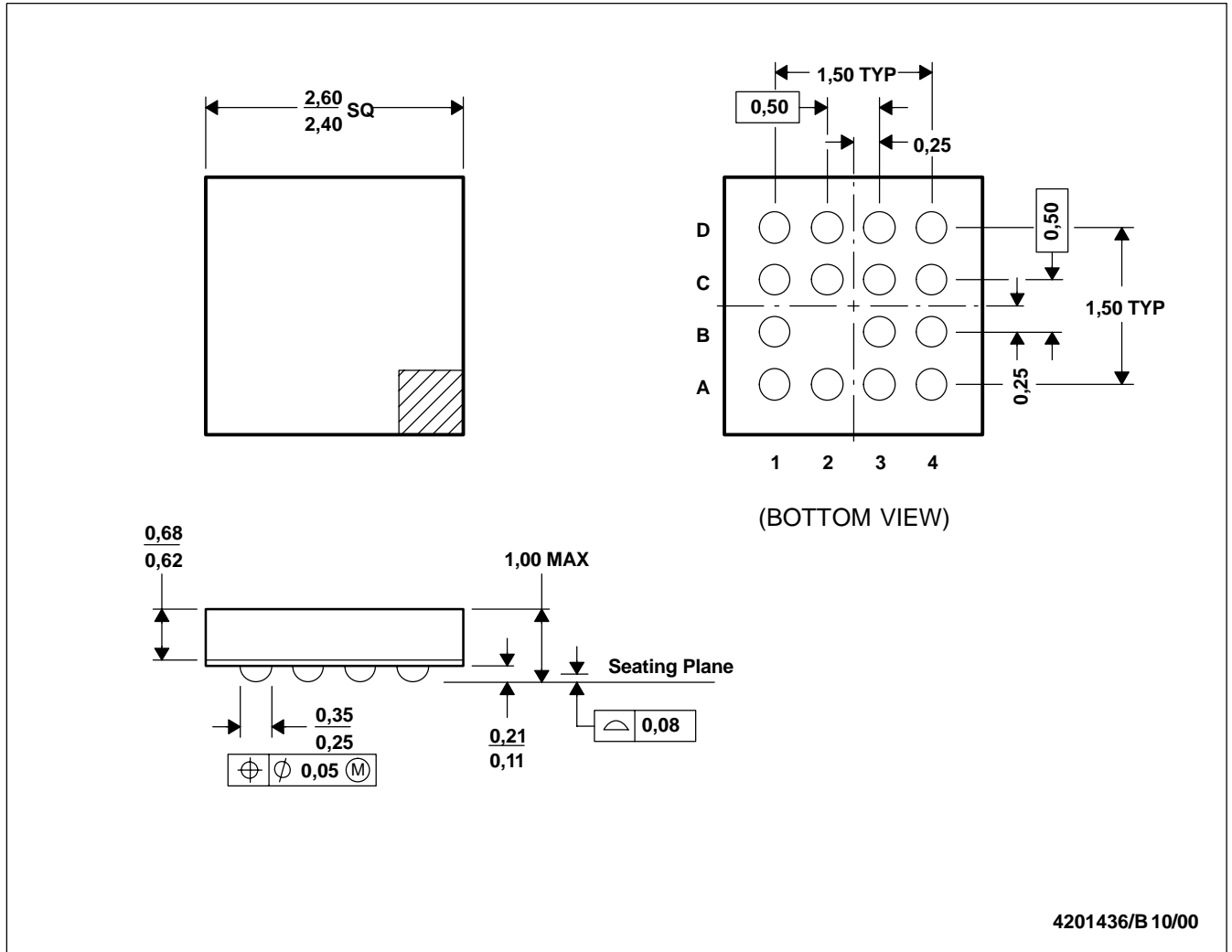

- NOTES:A. All linear dimensions are in millimeters.
 B. This drawing is subject to change without notice.
 C. MicroStar Junior™ configuration
 D. Falls within JEDEC MO-225

IMPORTANT NOTICE

Texas Instruments Incorporated and its subsidiaries (TI) reserve the right to make corrections, modifications, enhancements, improvements, and other changes to its products and services at any time and to discontinue any product or service without notice. Customers should obtain the latest relevant information before placing orders and should verify that such information is current and complete. All products are sold subject to TI's terms and conditions of sale supplied at the time of order acknowledgment.

TI warrants performance of its hardware products to the specifications applicable at the time of sale in accordance with TI's standard warranty. Testing and other quality control techniques are used to the extent TI deems necessary to support this warranty. Except where mandated by government requirements, testing of all parameters of each product is not necessarily performed.

TI assumes no liability for applications assistance or customer product design. Customers are responsible for their products and applications using TI components. To minimize the risks associated with customer products and applications, customers should provide adequate design and operating safeguards.

TI does not warrant or represent that any license, either express or implied, is granted under any TI patent right, copyright, mask work right, or other TI intellectual property right relating to any combination, machine, or process in which TI products or services are used. Information published by TI regarding third-party products or services does not constitute a license from TI to use such products or services or a warranty or endorsement thereof. Use of such information may require a license from a third party under the patents or other intellectual property of the third party, or a license from TI under the patents or other intellectual property of TI.

Reproduction of information in TI data books or data sheets is permissible only if reproduction is without alteration and is accompanied by all associated warranties, conditions, limitations, and notices. Reproduction of this information with alteration is an unfair and deceptive business practice. TI is not responsible or liable for such altered documentation.

Resale of TI products or services with statements different from or beyond the parameters stated by TI for that product or service voids all express and any implied warranties for the associated TI product or service and is an unfair and deceptive business practice. TI is not responsible or liable for any such statements.

Mailing Address:

Texas Instruments
Post Office Box 655303
Dallas, Texas 75265