

2.1 W/CH STEREO FILTER-FREE CLASS-D AUDIO POWER AMPLIFIER

FEATURES

- 2.1 W/Ch Into 4 Ω at 5 V
 - 1.4 W/Ch Into 8 Ω at 5 V
 - 720 mW/Ch Into 8 Ω at 3.6 V
- Only Two External Components Required
- Power Supply Range: 2.5 V to 5.5 V
- Independent Shutdown Control for Each Channel
- Selectable Gain of 6, 12, 18, and 24 dB
- Internal Pulldown Resistor On Shutdown Pins
- High PSRR: 77 dB at 217 Hz
- Fast Startup Time (3.5 ms)
- Low Supply Current
- Low Shutdown Current
- Short-Circuit and Thermal Protection
- Space Saving Packages
 - 2 mm X 2 mm NanoFree™ WCSP (YZH) (Future Product)
 - 4 mm X 4 mm Pb-Free Thin QFN (RTJ) with PowerPAD™

APPLICATIONS

- Wireless or Cellular Handsets and PDAs
- Portable DVD Player
- Notebook PC
- Portable Radio
- Portable Gaming
- Educational Toys
- USB Speakers

DESCRIPTION

The TPA2012D2 is a stereo, filter-free Class-D audio amplifier available in a WCSP or QFN package. The TPA2012D2 only requires two external components for operation.

The TPA2012D2 features independent shutdown controls for each channel. The gain can be selected to 6, 12, 18, or 24 dB utilizing the G0 and G1 gain select pins. High PSRR and differential architecture provide increased immunity to noise and RF rectification. In addition to these features, a fast startup time and small package size make the TPA2012D2 an ideal choice for both cellular handsets and PDAs.

The TPA2012D2 is capable of driving 1.4 W/Ch at 5 V or 720 mW/Ch at 3.6 V into 8 Ω . The TPA2012D2 is also capable of driving 4 Ω . The TPA2012D2 provides thermal and short circuit protection.

APPLICATION CIRCUIT

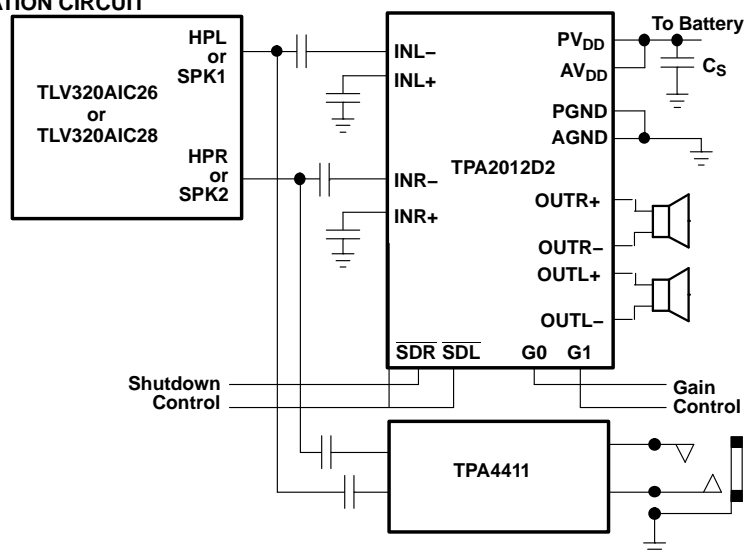

Please be aware that an important notice concerning availability, standard warranty, and use in critical applications of Texas Instruments semiconductor products and disclaimers thereto appears at the end of this data sheet.

NanoFree, PowerPAD are trademarks of Texas Instruments.



These devices have limited built-in ESD protection. The leads should be shorted together or the device placed in conductive foam during storage or handling to prevent electrostatic damage to the MOS gates.

AVAILABLE OPTIONS

T _A	PACKAGE	PART NUMBER	SYMBOL
-40°C to 85°C	2 mm x 2 mm WCSP (YZH)	TPA2012D2YZH	AKR
	4 mm x 4 mm, 20 pin QFN (RTJ)	TPA2012D2RTJ	AKS

ABSOLUTE MAXIMUM RATINGS

over operating free-air temperature (unless otherwise noted)⁽¹⁾

		UNITS
V _{SS}	Supply voltage, AVDD, PVDD	In active mode -0.3 V to 6.0 V
		In shutdown mode -0.3 V to 7.0 V
V _I	Input voltage	-0.3 V to V _{DD} + 0.3 V
	Continuous total power dissipation	See Dissipation Rating Table
T _A	Operating free-air temperature range	- 40°C to 85°C
T _J	Operating junction temperature range	- 40°C to 150°C
T _{stg}	Storage temperature range	-65°C to 85°C

(1) Stresses beyond those listed under "absolute maximum ratings" may cause permanent damage to the device. These are stress ratings only, and functional operation of the device at these or any other conditions beyond those indicated under "recommended operating conditions" is not implied. Exposure to absolute-maximum-rated conditions for extended periods may affect device reliability.

DISSIPATION RATING TABLE

PACKAGE	T _A = 25°C POWER RATING ⁽¹⁾	Derating Factor	T _A = 75°C POWER RATING	T _A = 85°C POWER RATING
RTJ	5.2 W	41.6 mW/°C	3.12 W	2.7 W
YZH ⁽²⁾	TBD	TBD	TBD	TBD

(1) This data was taken using 2 oz trace and copper pad that is soldered directly to a JEDEC standard 4-layer 3 in × 3 in PCB.
 (2) Product preview

RECOMMENDED OPERATING CONDITIONS

			MIN	MAX	UNIT
V _{SS}	Supply voltage	AVDD, PVDD	2.5	5.5	V
V _{IH}	High-level input voltage	\overline{SDL} , \overline{SDR} , G0, G1	1.3		V
V _{IL}	Low-level input voltage	\overline{SDL} , \overline{SDR} , G0, G1		0.35	V
T _A	Operating free-air temperature		- 40	85	°C

ELECTRICAL CHARACTERISTICS

over operating free-air temperature range (unless otherwise noted)

PARAMETER		TEST CONDITIONS	MIN	TYP	MAX	UNIT
$ V_{ool} $	Output offset voltage (measured differentially)	Inputs ac grounded, $A_V = 6$ dB, $V_{DD} = 2.5$ to 5.5 V		5	25	mV
PSRR	Power supply rejection ratio	$V_{DD} = 2.5$ to 5.5 V		-75	-55	dB
V_{icm}	Common-mode input voltage		0.5		$V_{DD}-0.8$	V
CMRR	Common-mode rejection ratio	Inputs shorted together, $V_{DD} = 2.5$ to 5.5 V		-69	-50	dB
$ I_{IH} $	High-level input current	$V_{DD} = 5.5$ V, $V_I = V_{DD}$			50	μ A
$ I_{IL} $	Low-level input current	$V_{DD} = 5.5$ V, $V_I = 0$ V			5	μ A
I_{DD}	Supply current	$V_{DD} = 5.5$ V, No load		6	9	mA
		$V_{DD} = 3.6$ V, No load		5	7.5	
		$V_{DD} = 2.5$ V, No load		4	6	
		Shutdown mode				1.5
$r_{DS(on)}$	Static drain-source on-state resistance	$V_{DD} = 5.5$ V		500		m Ω
		$V_{DD} = 3.6$ V		570		
		$V_{DD} = 2.5$ V		700		
	Output impedance in shutdown mode	$V_{(SDR, SDL)} = 0.35$ V		2		k Ω
$f_{(sw)}$	Switching frequency	$V_{DD} = 2.5$ V to 5.5 V	250	300	350	kHz
	Closed-loop voltage gain	$G_0, G_1 = 0.35$ V	5.5	6	6.5	dB
		$G_0 = V_{DD}, G_1 = 0.35$ V	11.5	12	12.5	
		$G_0 = 0.35$ V, $G_1 = V_{DD}$	17.5	18	18.5	
		$G_0, G_1 = V_{DD}$	23.5	24	24.5	

OPERATING CHARACTERISTICS

$T_A = 25^\circ\text{C}$, $R_L = 8 \Omega$, (unless otherwise noted)

PARAMETER		TEST CONDITIONS		MIN	TYP	MAX	UNIT
P_O	Output power (per channel)	$R_L = 8 \Omega$	$V_{DD} = 5.0$ V, $f = 1$ kHz, THD = 10%		1.4		W
			$V_{DD} = 3.6$ V, $f = 1$ kHz, THD = 10%		0.72		
		$R_L = 4 \Omega$	$V_{DD} = 5.0$ V, $f = 1$ kHz, THD = 10%		2.1		
THD+N	Total harmonic distortion plus noise	$P_O = 1$ W, $V_{DD} = 5$ V, $A_V = 6$ dB	$f = 1$ kHz		0.14%		
		$P_O = 0.5$ W, $V_{DD} = 5$ V, $A_V = 6$ dB	$f = 1$ kHz		0.11%		
	Channel crosstalk	$f = 1$ kHz			-85		dB
k_{SVR}	Supply ripple rejection ratio	$V_{DD} = 5$ V, $A_V = 6$ dB	$f = 217$ Hz		-77		dB
		$V_{DD} = 3.6$ V, $A_V = 6$ dB	$f = 217$ Hz		-73		
CMRR	Common mode rejection ratio	$V_{DD} = 3.6$ V, $V_{IC} = 1$ V _{pp}	$f = 217$ Hz		-69		dB
	Input impedance	$A_V = 6$ dB			28.1		k Ω
		$A_V = 12$ dB			17.3		
		$A_V = 18$ dB			9.8		
		$A_V = 24$ dB			5.2		
	Start-up time from shutdown	$V_{DD} = 3.6$ V			3.5		ms
V_n	Output voltage noise	$V_{DD} = 3.6$ V, $f = 20$ to 20 kHz, Inputs are ac grounded, $A_V = 6$ dB	No weighting		35		μ V
			A weighting		27		

BLOCK DIAGRAM

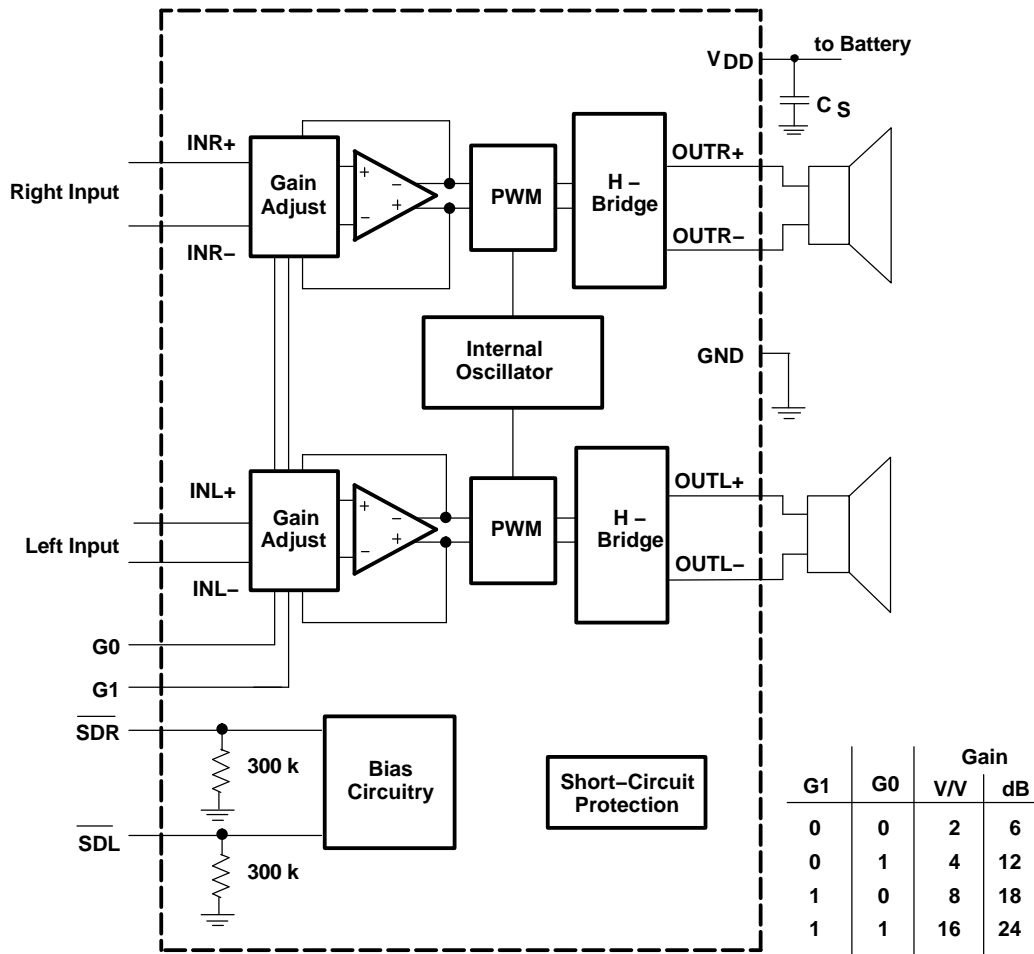

Terminal Functions

TERMINAL			I/O	DESCRIPTION
NAME	QFN	WCSP		
INR+	16	D1	I	Right channel positive input
INR-	17	C1	I	Right channel negative input
INL+	20	A1	I	Left channel positive input
INL-	19	B1	I	Left channel negative input
$\overline{\text{SDR}}$	8	B3	I	Right channel shutdown terminal (active low)
$\overline{\text{SDL}}$	7	B4	I	Left channel shutdown terminal (active low)
G0	15	C2	I	Gain select (LSB)
G1	1	B2	I	Gain select (MSB)
PVDD	3, 13	A2	I	Power supply (Must be same voltage as AVDD)
AVDD	9	D2	I	Analog supply (Must be same voltage as PVDD)
PGND	4, 12	C4	I	Power ground
AGND	18	C3	I	Analog ground
OUTR+	14	D3	O	Right channel positive differential output
OUTR-	11	D4	O	Right channel negative differential output
OUTL+	2	A3	O	Left channel positive differential output
OUTL-	5	A4	O	Left channel negative differential output
NC	6, 10	N/A		No internal connection
Thermal Pad				Connect the thermal pad of QFN package to GND.

**WCSP PIN OUT
TOP VIEW**

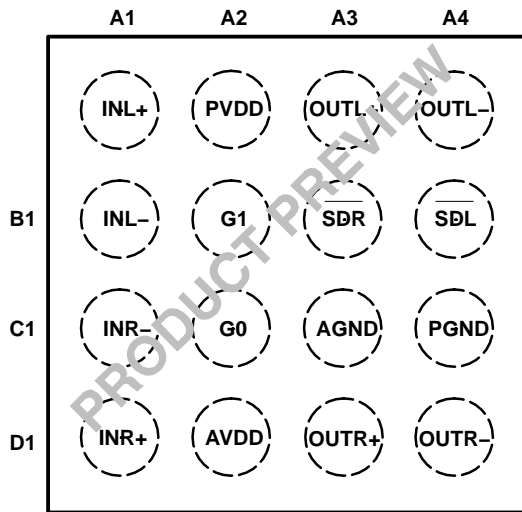

**RTJ PIN OUT
TOP VIEW**

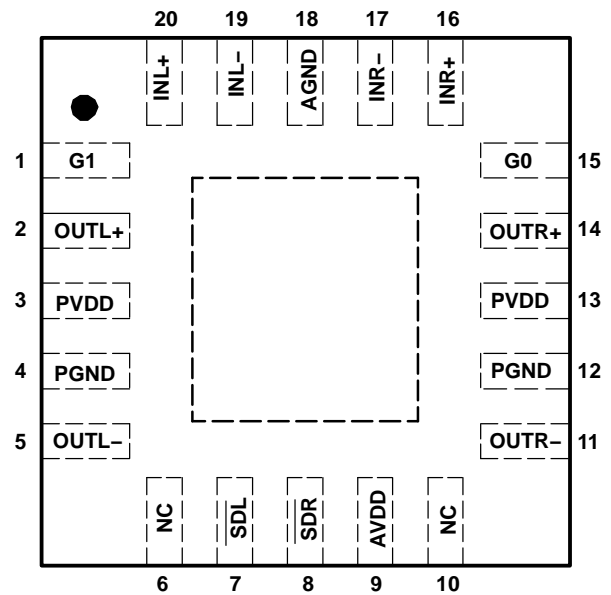

TYPICAL CHARACTERISTICS

TOTAL HARMONIC DISTORTION
VS
OUTPUT POWER

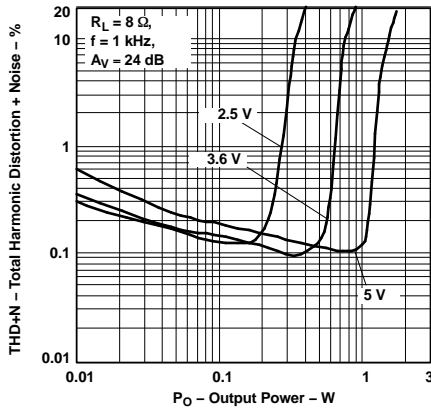

Figure 1.

TOTAL HARMONIC DISTORTION
VS
OUTPUT POWER

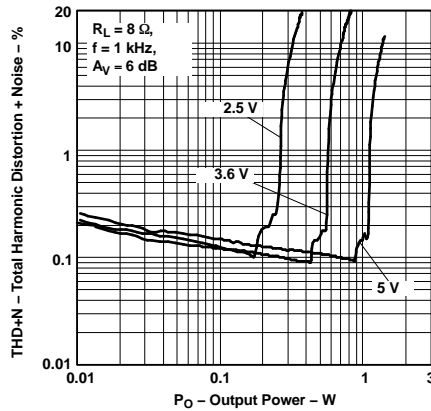

Figure 2.

TOTAL HARMONIC DISTORTION
VS
OUTPUT POWER

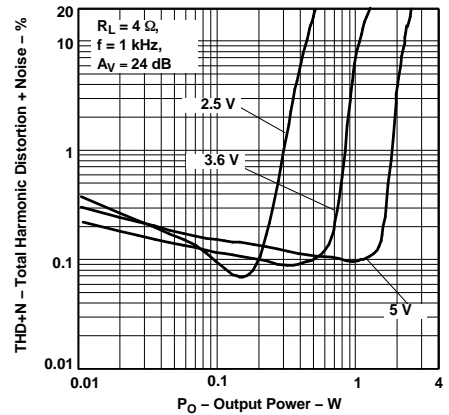

Figure 3.

TOTAL HARMONIC DISTORTION
VS
OUTPUT POWER

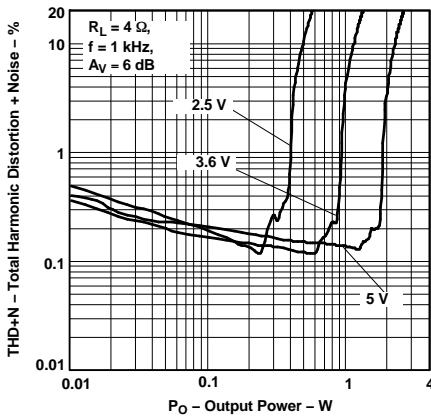

Figure 4.

SUPPLY CURRENT
VS
SHUTDOWN VOLTAGE

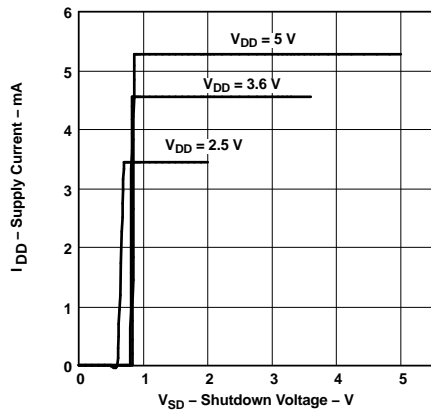

Figure 5.

SUPPLY CURRENT
VS
SUPPLY VOLTAGE

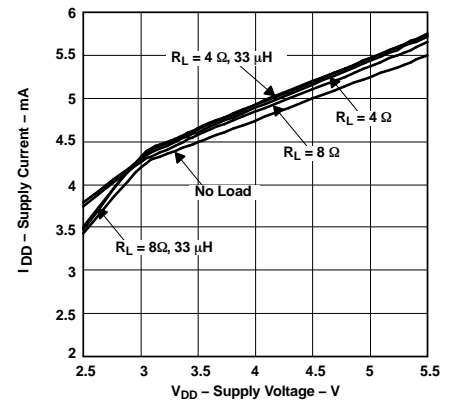

Figure 6.

TOTAL HARMONIC DISTORTION
VS
FREQUENCY

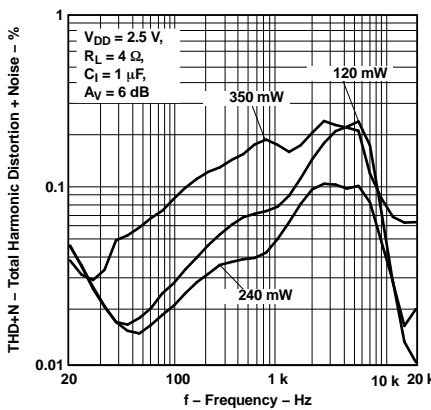

Figure 7.

TOTAL HARMONIC DISTORTION
VS
FREQUENCY

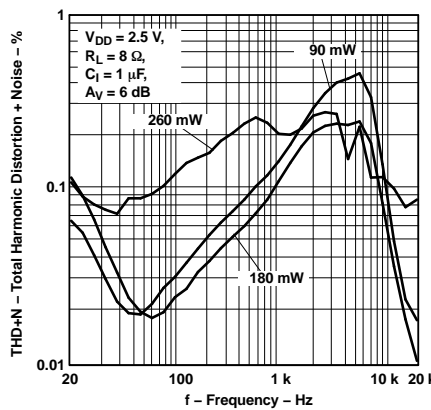

Figure 8.

TOTAL HARMONIC DISTORTION
VS
FREQUENCY

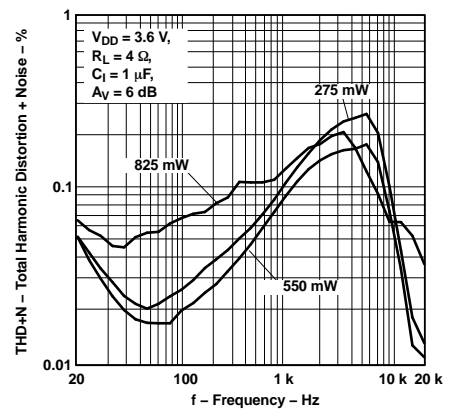

Figure 9.

TYPICAL CHARACTERISTICS (continued)

TOTAL HARMONIC DISTORTION VS FREQUENCY

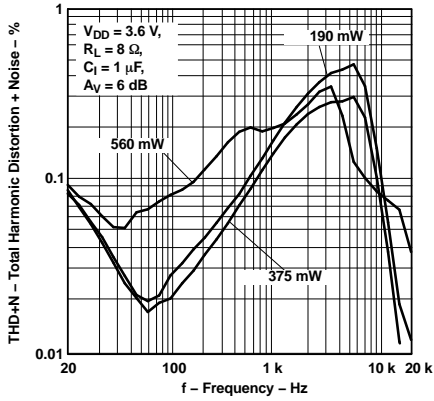

Figure 10.

TOTAL HARMONIC DISTORTION VS FREQUENCY

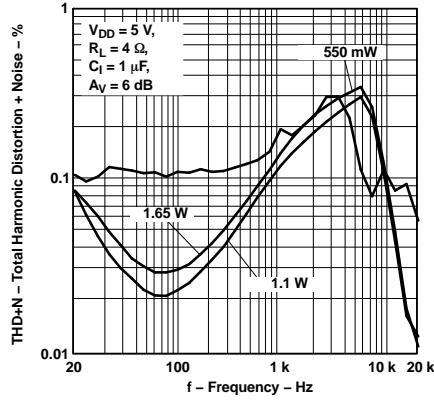

Figure 11.

TOTAL HARMONIC DISTORTION VS FREQUENCY

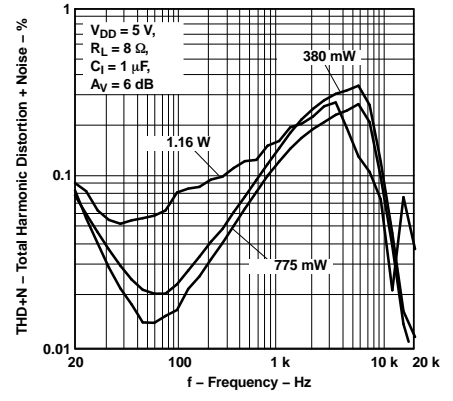

Figure 12.

CROSSTALK VS FREQUENCY

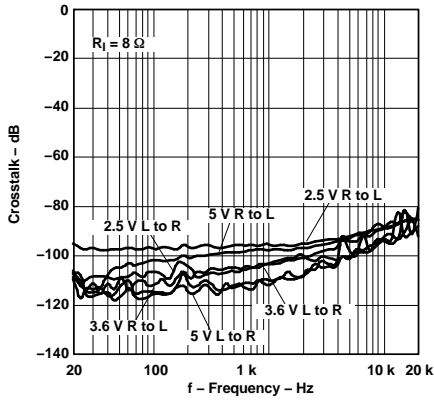

Figure 13.

CROSSTALK VS FREQUENCY

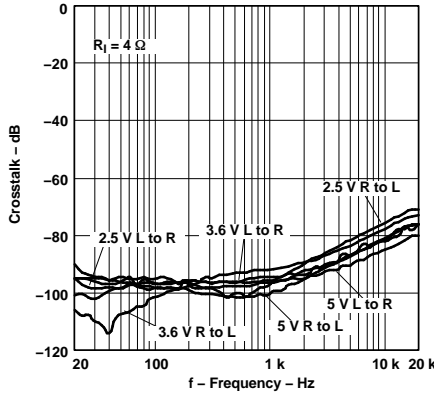

Figure 14.

POWER SUPPLY REJECTION RATIO VS FREQUENCY

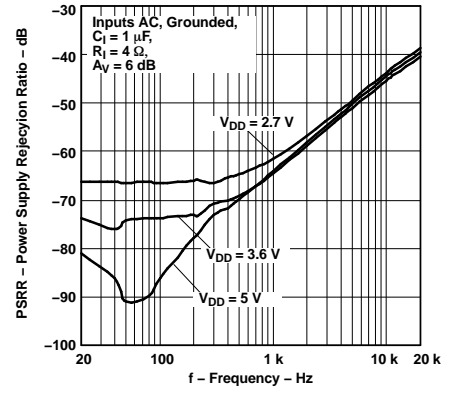

Figure 15.

TYPICAL CHARACTERISTICS (continued)

POWER SUPPLY REJECTION RATIO VS FREQUENCY

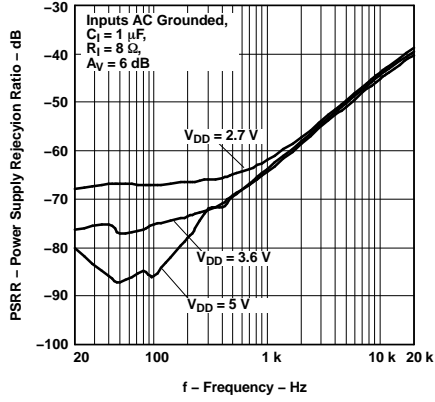

Figure 16.

COMMON-MODE REJECTION RATIO VS COMMON-MODE INPUT VOLTAGE

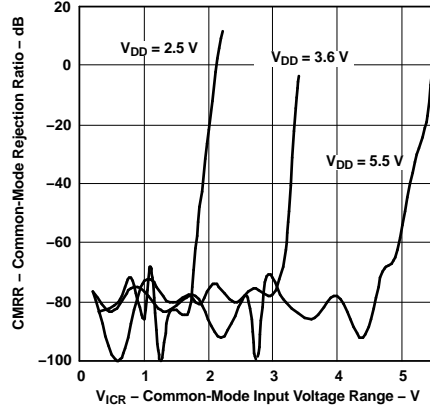

Figure 17.

COMMON-MODE REJECTION RATIO VS FREQUENCY

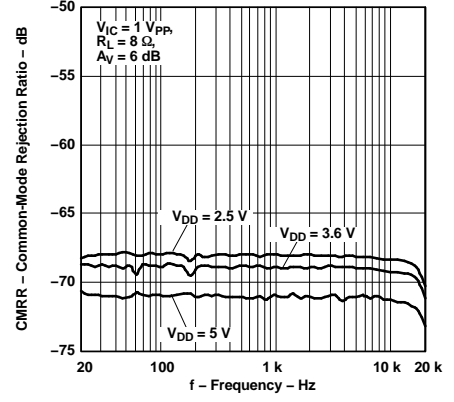

Figure 18.

GSM POWER SUPPLY REJECTION VS TIME

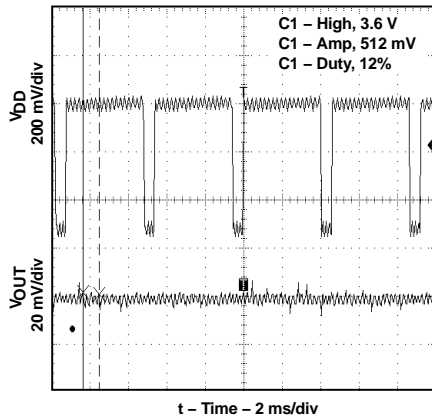

Figure 19.

POWER SUPPLY REJECTION VS FREQUENCY

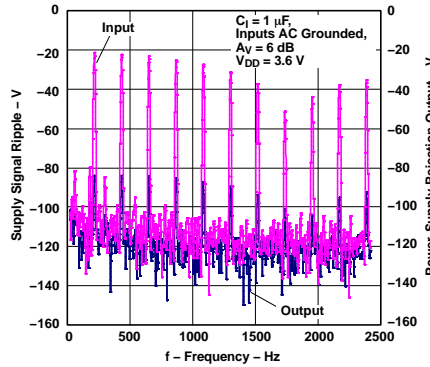

Figure 20.

POWER DISSIPATION VS OUTPUT POWER

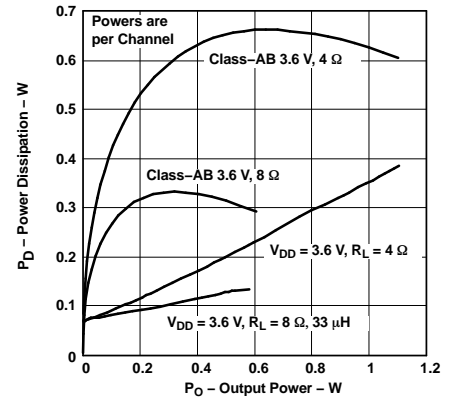

Figure 21.

TYPICAL CHARACTERISTICS (continued)

**POWER DISSIPATION
VS
OUTPUT POWER**

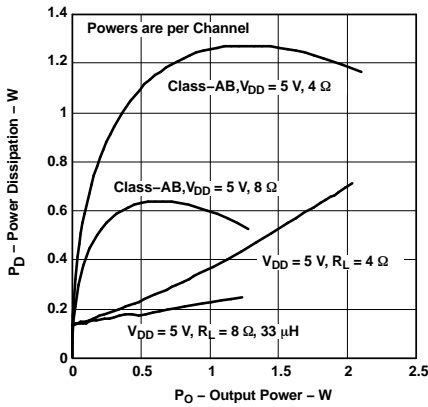

Figure 22.

**EFFICIENCY
VS
OUTPUT POWER**

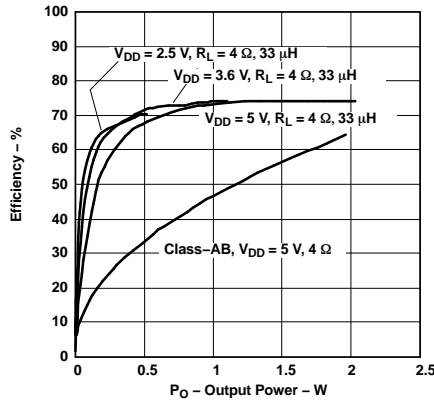

Figure 23.

**EFFICIENCY
VS
OUTPUT POWER**

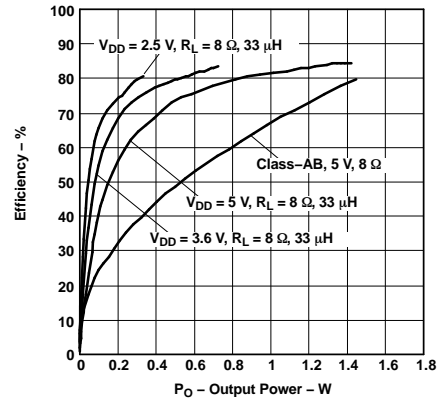

Figure 24.

**SUPPLY CURRENT
VS
OUTPUT POWER**

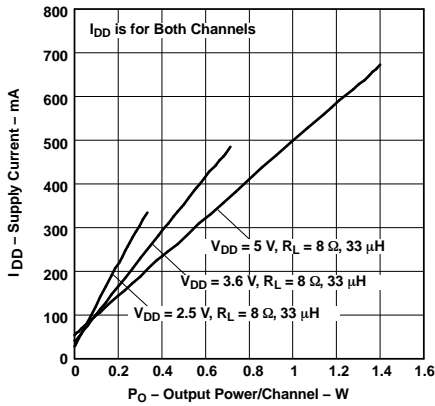

Figure 25.

**SUPPLY CURRENT
VS
OUTPUT POWER**

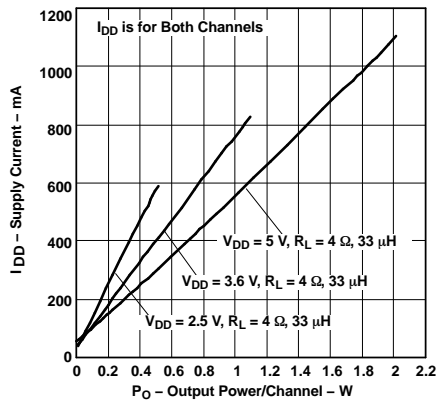

Figure 26.

**OUTPUT POWER
VS
SUPPLY VOLTAGE**

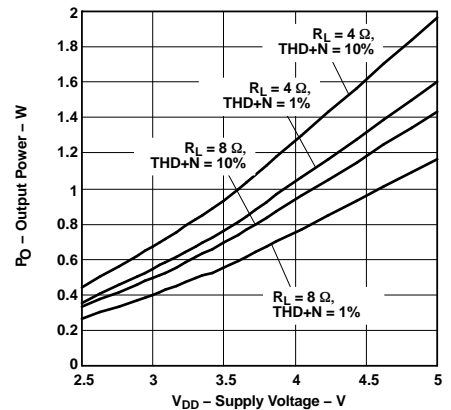

Figure 27.

**OUTPUT POWER
VS
SUPPLY VOLTAGE**

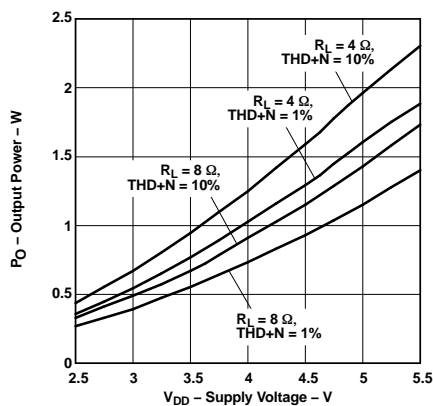

Figure 28.

**SUPPLY VOLTAGE
REJECTION RATIO
VS
DC COMMON-MODE VOLTAGE**

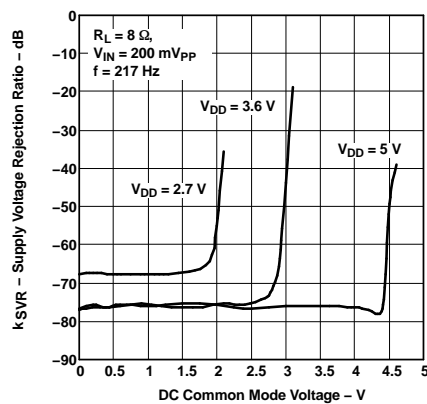
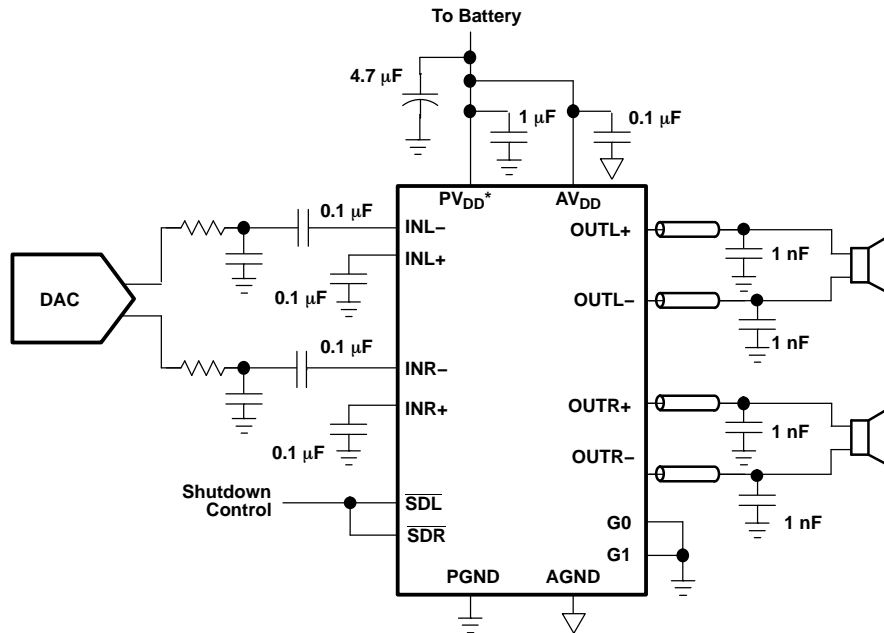

Figure 29.

APPLICATION INFORMATION



* For QFN, an additional capacitor is recommended for the second PV_{DD} pin.

Figure 30. Typical Application Circuit

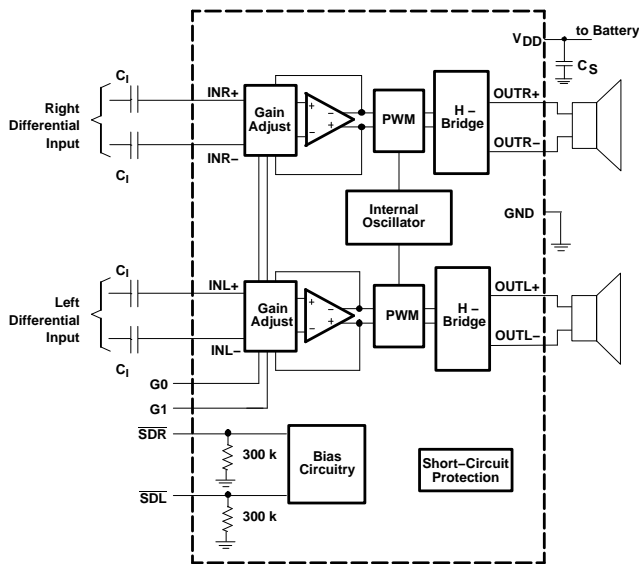

Figure 31. TPA2012D2 Application Schematic With Differential Input and Input Capacitors

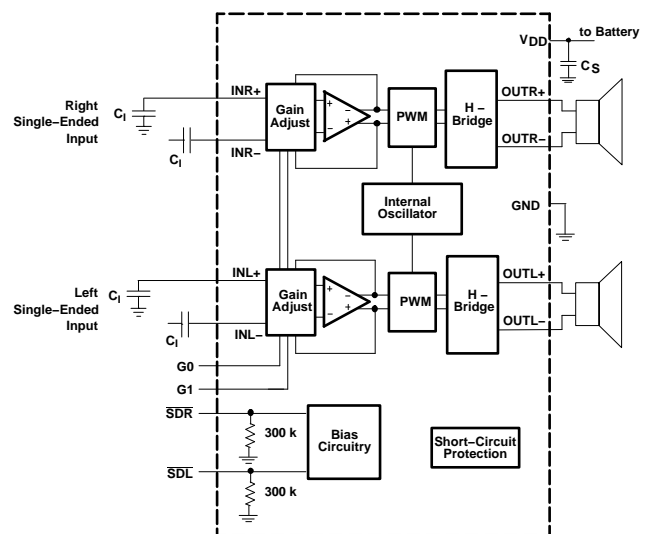

Figure 32. TPA2012D2 Application Schematic With Single-Ended Input

Decoupling Capacitor (C_S)

The TPA2012D2 is a high-performance Class-D audio amplifier that requires adequate power supply decoupling to ensure the efficiency is high and total harmonic distortion (THD) is low. For higher frequency transients, spikes, or digital hash on the line, a good low equivalent-series-resistance (ESR) ceramic capacitor, typically 1 μF, placed as close as possible to the device PV_{DD} lead works best. Placing this decoupling capacitor close to the TPA2012D2 is important for the efficiency of the Class-D amplifier, because any resistance or inductance in the trace between the device and the capacitor can cause a loss in efficiency. For filtering lower-frequency noise signals, a 4.7 μF or greater capacitor placed near the audio power amplifier would also help, but it is not required in most applications because of the high PSRR of this device.

Table 1. Gain Setting

G1	G0	GAIN (V/V)	GAIN (dB)	INPUT IMPEDANCE (R _I) (kΩ)
0	0	2	6	28.1
0	1	4	12	17.3
1	0	8	18	9.8
1	1	16	24	5.2

Input Capacitors (C_I)

The TPA2012D2 does not require input coupling capacitors if the design uses a differential source that is biased from 0.5 V to V_{DD} - 0.8 V. If the input signal is not biased within the recommended common-mode input range, if high pass filtering is needed (see Figure 31), or if using a single-ended source (see Figure 32), input coupling capacitors are required.

The input capacitors and input resistors form a high-pass filter with the corner frequency, f_c, determined in Equation 1.

$$f_c = \frac{1}{(2\pi R_I C_I)} \quad (1)$$

The value of the input capacitor is important to consider as it directly affects the bass (low frequency) performance of the circuit. Speakers in wireless phones cannot usually respond well to low frequencies, so the corner frequency can be set to block low frequencies in this application. Not using input capacitors can increase output offset.

Equation 2 is used to solve for the input coupling capacitance.

$$C_I = \frac{1}{(2\pi R_I f_c)} \quad (2)$$

If the corner frequency is within the audio band, the capacitors should have a tolerance of ±10% or better, because any mismatch in capacitance causes an impedance mismatch at the corner frequency and below.

BOARD LAYOUT

In making the pad size for the WCSP balls, it is recommended that the layout use nonsolder mask defined (NSMD) land. With this method, the solder mask opening is made larger than the desired land area, and the opening size is defined by the copper pad width. Figure 33 and Table 2 shows the appropriate diameters for a WCSP layout. The TPA2012D2 evaluation module (EVM) layout is shown in the next section as a layout example.

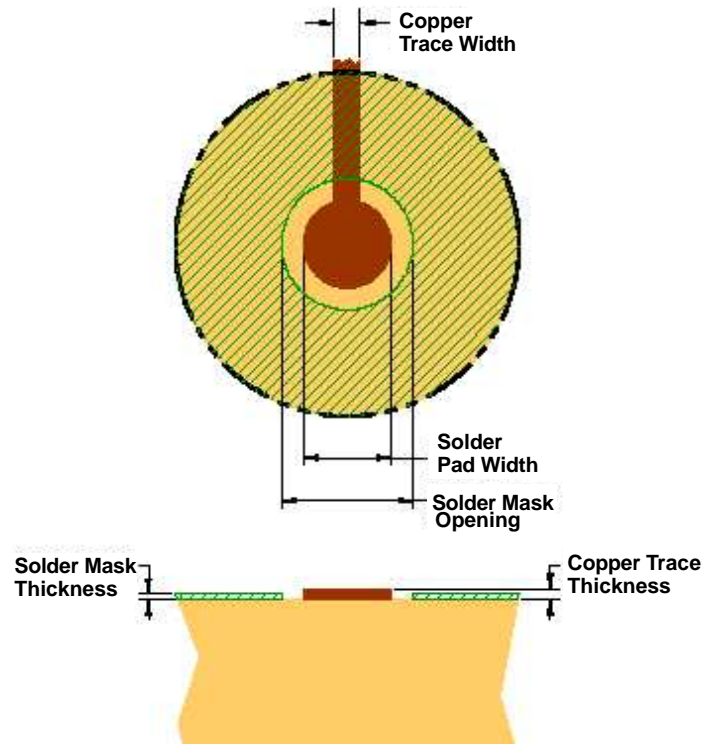

Figure 33. Land Pattern Dimensions

Table 2. Land Pattern Dimensions⁽¹⁾⁽²⁾⁽³⁾⁽⁴⁾

SOLDER PAD DEFINITIONS	COPPER PAD	SOLDER MASK ⁽⁵⁾ OPENING	COPPER THICKNESS	STENCIL ⁽⁶⁾⁽⁷⁾ OPENING	STENCIL THICKNESS
Nonsolder mask defined (NSMD)	275 μm (+0.0, -25 μm)	375 μm (+0.0, -25 μm)	1 oz max (32 μm)	275 μm x 275 μm Sq. (rounded corners)	125 μm thick

- (1) Circuit traces from NSMD defined PWB lands should be 75 μm to 100 μm wide in the exposed area inside the solder mask opening. Wider trace widths reduce device stand off and impact reliability.
- (2) Best reliability results are achieved when the PWB laminate glass transition temperature is above the operating the range of the intended application.
- (3) Recommend solder paste is Type 3 or Type 4.
- (4) For a PWB using a Ni/Au surface finish, the gold thickness should be less 0.5 mm to avoid a reduction in thermal fatigue performance.
- (5) Solder mask thickness should be less than 20 μm on top of the copper circuit pattern
- (6) Best solder stencil performance is achieved using laser cut stencils with electro polishing. Use of chemically etched stencils results in inferior solder paste volume control.
- (7) Trace routing away from WCSP device should be balanced in X & Y directions to avoid unintentional component movement due to solder wetting forces.

Component Location

Place all the external components very close to the TPA2012D2. Placing the decoupling capacitor, C_S, close to the TPA2012D2 is important for the efficiency of the Class-D amplifier. Any resistance or inductance in the trace between the device and the capacitor can cause a loss in efficiency.

Trace Width

Recommended trace width at the solder balls is 75 μm to 100 μm to prevent solder wicking onto wider PCB traces.

For high current pins (PV_{DD}, PGND, and audio output pins) of the TPA2012D2, use 100-μm trace widths at the solder balls and at least 500-μm PCB traces to ensure proper performance and output power for the device.

For the remaining signals of the TPA2012D2, use 75-μm to 100-μm trace widths at the solder balls. The audio input pins (INR+/- and INL+/-) must run side-by-side to maximize common-mode noise cancellation.

EFFICIENCY AND THERMAL INFORMATION

The maximum ambient temperature depends on the heat-sinking ability of the PCB system. The derating factor for the packages are shown in the dissipation rating table. Converting this to θ_{JA} for the QFN package:

$$\theta_{JA} = \frac{1}{\text{Derating Factor}} = \frac{1}{0.041} = 24^{\circ}\text{C/W} \quad (3)$$

Given θ_{JA} of 24°C/W, the maximum allowable junction temperature of 150°C, and the maximum internal dissipation of 1.5W (0.75 W per channel) for 2.1 W per channel, 4-Ω load, 5-V supply, from Figure 3, the maximum ambient temperature can be calculated with the following equation.

$$T_{A\text{Max}} = T_{J\text{Max}} - \theta_{JA} P_{D\text{max}} = 150 - 24 (1.5) = 114^{\circ}\text{C} \quad (4)$$

Equation 4 shows that the calculated maximum ambient temperature is 114°C at maximum power dissipation with a 5-V supply and 4-Ω a load. The TPA2012D2 is designed with thermal protection that turns the device off when the junction temperature surpasses 150°C to prevent damage to the IC. Also, using speakers more resistive than 4-Ω dramatically increases the thermal performance by reducing the output current and increasing the efficiency of the amplifier.

FILTER FREE OPERATION AND FERRITE BEAD FILTERS

A ferrite bead filter can often be used if the design is failing radiated emissions without an LC filter and the frequency sensitive circuit is greater than 1 MHz. This filter functions well for circuits that just have to pass FCC and CE because FCC and CE only test radiated emissions greater than 30 MHz. When choosing a ferrite bead, choose one with high impedance at high frequencies, and very low impedance at low frequencies. In addition, select a ferrite bead with adequate current rating to prevent distortion of the output signal.

Use an LC output filter if there are low frequency (< 1 MHz) EMI sensitive circuits and/or there are long leads from amplifier to speaker.

Figure 34 shows typical ferrite bead and LC output filters.

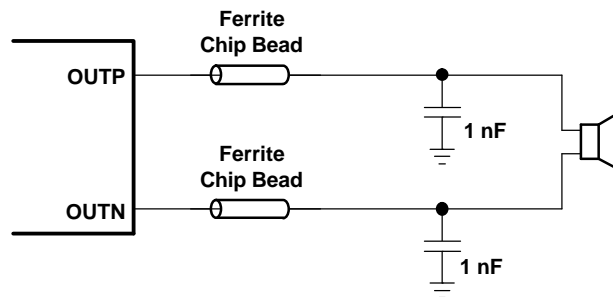

Figure 34. Typical Ferrite Chip Bead Filter (Chip bead example: TDK: MPZ1608S221A)

PACKAGING INFORMATION

Orderable Device	Status ⁽¹⁾	Package Type	Package Drawing	Pins	Package Qty	Eco Plan ⁽²⁾	Lead/Ball Finish	MSL Peak Temp ⁽³⁾
TPA2012D2RTJR	ACTIVE	QFN	RTJ	20	3000	Green (RoHS & no Sb/Br)	CU NIPDAU	Level-2-260C-1 YEAR
TPA2012D2RTJRG4	ACTIVE	QFN	RTJ	20	3000	None	Call TI	Call TI
TPA2012D2RTJT	ACTIVE	QFN	RTJ	20	250	Green (RoHS & no Sb/Br)	CU NIPDAU	Level-2-260C-1 YEAR
TPA2012D2RTJTG4	ACTIVE	QFN	RTJ	20	250	None	Call TI	Call TI

⁽¹⁾ The marketing status values are defined as follows:

ACTIVE: Product device recommended for new designs.

LIFEBUY: TI has announced that the device will be discontinued, and a lifetime-buy period is in effect.

NRND: Not recommended for new designs. Device is in production to support existing customers, but TI does not recommend using this part in a new design.

PREVIEW: Device has been announced but is not in production. Samples may or may not be available.

OBSOLETE: TI has discontinued the production of the device.

⁽²⁾ Eco Plan - May not be currently available - please check <http://www.ti.com/productcontent> for the latest availability information and additional product content details.

None: Not yet available Lead (Pb-Free).

Pb-Free (RoHS): TI's terms "Lead-Free" or "Pb-Free" mean semiconductor products that are compatible with the current RoHS requirements for all 6 substances, including the requirement that lead not exceed 0.1% by weight in homogeneous materials. Where designed to be soldered at high temperatures, TI Pb-Free products are suitable for use in specified lead-free processes.

Green (RoHS & no Sb/Br): TI defines "Green" to mean "Pb-Free" and in addition, uses package materials that do not contain halogens, including bromine (Br) or antimony (Sb) above 0.1% of total product weight.

⁽³⁾ MSL, Peak Temp. -- The Moisture Sensitivity Level rating according to the JEDEC industry standard classifications, and peak solder temperature.

Important Information and Disclaimer: The information provided on this page represents TI's knowledge and belief as of the date that it is provided. TI bases its knowledge and belief on information provided by third parties, and makes no representation or warranty as to the accuracy of such information. Efforts are underway to better integrate information from third parties. TI has taken and continues to take reasonable steps to provide representative and accurate information but may not have conducted destructive testing or chemical analysis on incoming materials and chemicals. TI and TI suppliers consider certain information to be proprietary, and thus CAS numbers and other limited information may not be available for release.

In no event shall TI's liability arising out of such information exceed the total purchase price of the TI part(s) at issue in this document sold by TI to Customer on an annual basis.

RTJ (S-PQFP-N20)

PLASTIC QUAD FLATPACK

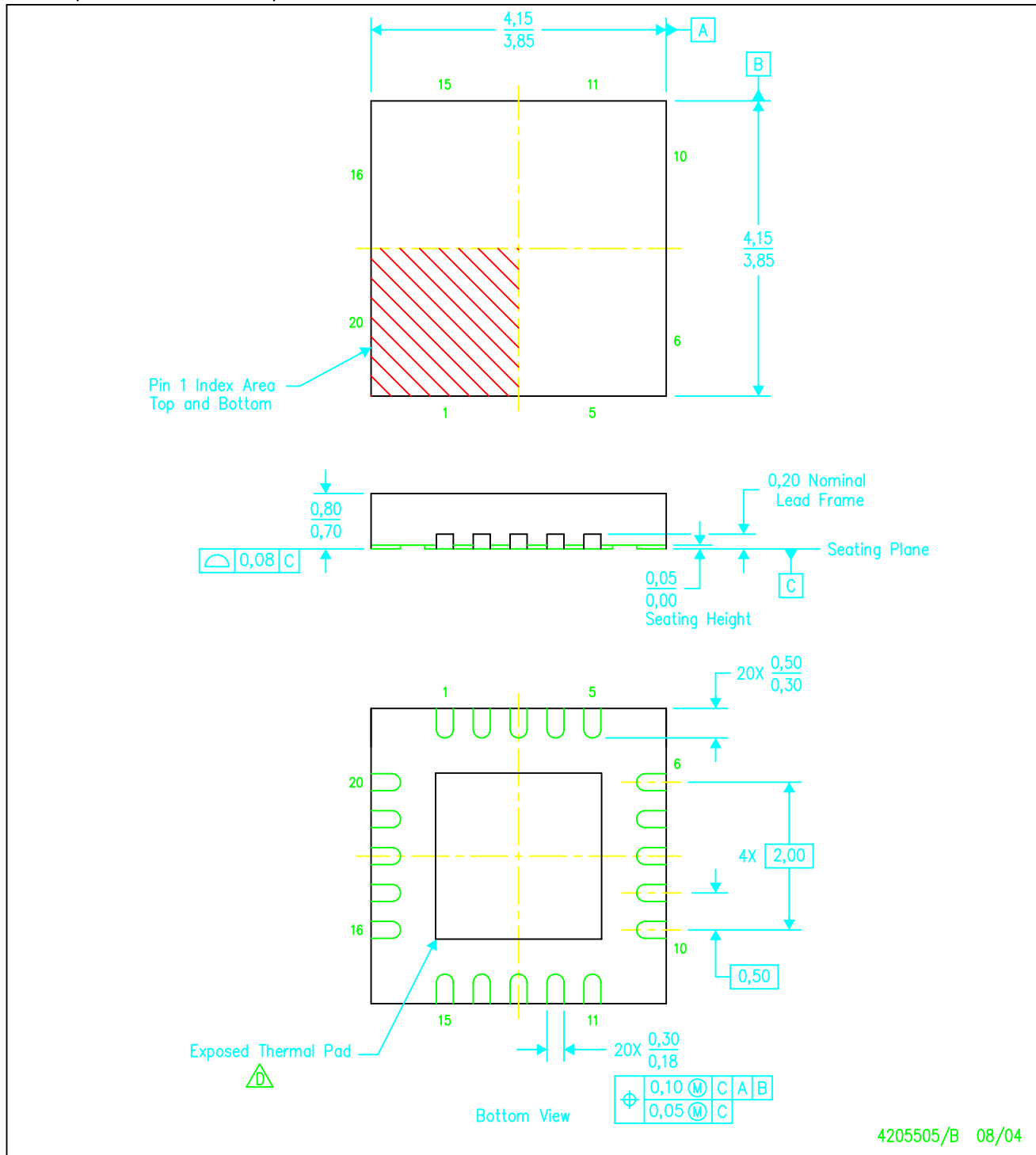

- NOTES:
- A. All linear dimensions are in millimeters. Dimensioning and tolerancing per ASME Y14.5-1994.
 - B. This drawing is subject to change without notice.
 - C. QFN (Quad Flatpack No-Lead) package configuration.
 - The package thermal pad must be soldered to the board for thermal and mechanical performance. See the Product Data Sheet for details regarding the exposed thermal pad dimensions.

IMPORTANT NOTICE

Texas Instruments Incorporated and its subsidiaries (TI) reserve the right to make corrections, modifications, enhancements, improvements, and other changes to its products and services at any time and to discontinue any product or service without notice. Customers should obtain the latest relevant information before placing orders and should verify that such information is current and complete. All products are sold subject to TI's terms and conditions of sale supplied at the time of order acknowledgment.

TI warrants performance of its hardware products to the specifications applicable at the time of sale in accordance with TI's standard warranty. Testing and other quality control techniques are used to the extent TI deems necessary to support this warranty. Except where mandated by government requirements, testing of all parameters of each product is not necessarily performed.

TI assumes no liability for applications assistance or customer product design. Customers are responsible for their products and applications using TI components. To minimize the risks associated with customer products and applications, customers should provide adequate design and operating safeguards.

TI does not warrant or represent that any license, either express or implied, is granted under any TI patent right, copyright, mask work right, or other TI intellectual property right relating to any combination, machine, or process in which TI products or services are used. Information published by TI regarding third-party products or services does not constitute a license from TI to use such products or services or a warranty or endorsement thereof. Use of such information may require a license from a third party under the patents or other intellectual property of the third party, or a license from TI under the patents or other intellectual property of TI.

Reproduction of information in TI data books or data sheets is permissible only if reproduction is without alteration and is accompanied by all associated warranties, conditions, limitations, and notices. Reproduction of this information with alteration is an unfair and deceptive business practice. TI is not responsible or liable for such altered documentation.

Resale of TI products or services with statements different from or beyond the parameters stated by TI for that product or service voids all express and any implied warranties for the associated TI product or service and is an unfair and deceptive business practice. TI is not responsible or liable for any such statements.

Following are URLs where you can obtain information on other Texas Instruments products and application solutions:

Products		Applications	
Amplifiers	amplifier.ti.com	Audio	www.ti.com/audio
Data Converters	dataconverter.ti.com	Automotive	www.ti.com/automotive
DSP	dsp.ti.com	Broadband	www.ti.com/broadband
Interface	interface.ti.com	Digital Control	www.ti.com/digitalcontrol
Logic	logic.ti.com	Military	www.ti.com/military
Power Mgmt	power.ti.com	Optical Networking	www.ti.com/opticalnetwork
Microcontrollers	microcontroller.ti.com	Security	www.ti.com/security
		Telephony	www.ti.com/telephony
		Video & Imaging	www.ti.com/video
		Wireless	www.ti.com/wireless

Mailing Address: Texas Instruments
Post Office Box 655303 Dallas, Texas 75265