

1.7-W MONO FULLY DIFFERENTIAL AUDIO POWER AMPLIFIER

FEATURES

- Designed for Wireless or Cellular Handsets and PDAs
- 1.7 W Into 8 Ω From a 5-V Supply at THD = 10% (Typ)
- Low Supply Current: 4 mA typ at 5 V
- Shutdown Current: 0.01 μA Typ
- Fast Startup With Minimal Pop
- Only Three External Components
 - Improved PSRR (–80 dB) and Wide Supply Voltage (2.5 V to 5.5 V) for Direct Battery Operation
 - Fully Differential Design Reduces RF Rectification
 - –63 dB CMRR Eliminates Two Input Coupling Capacitors
- Pin to Pin Compatible With TPA2005D1 and TPA6211A1 in QFN Package
- Available in 3 mm X 3 mm QFN Package (DRB)

APPLICATIONS

- Ideal for Wireless Handsets
- PDAs
- Notebook Computers

DESCRIPTION

The TPA6204A1 is a 1.7-W mono fully-differential amplifier designed to drive a speaker with at least 8-Ω impedance while consuming only 20 mm² total printed-circuit board (PCB) area in most applications. The device operates from 2.5 V to 5.5 V, drawing only 4 mA of quiescent supply current. The TPA6204A1 is available in the space-saving 3 mm x 3 mm QFN (DRB) package.

The TPA6204A1 is ideal for PDA/smart phone applications due to features such as –80-dB supply voltage rejection from 20 Hz to 2 kHz, improved RF rectification immunity, small PCB area, and a fast startup with minimal pop.

APPLICATION CIRCUIT

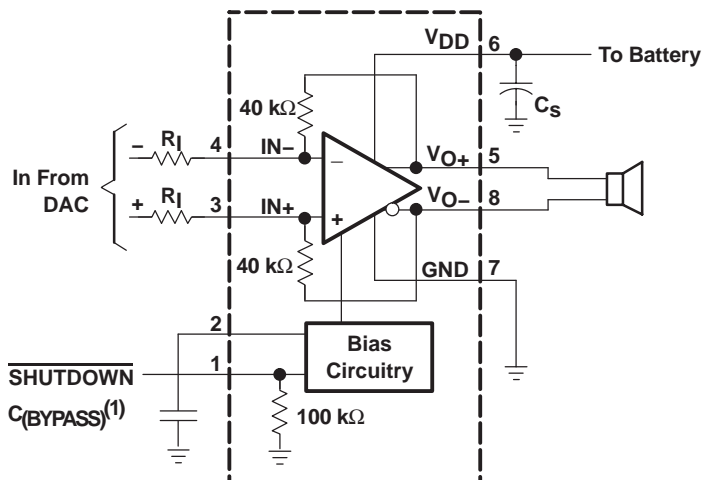

(1) C_(BYPASS) is optional.

8-pin QFN (DRB) PACKAGE
(TOP VIEW)

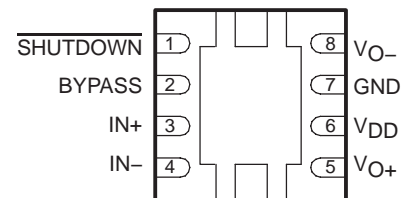

DGN Package
(TOP VIEW)

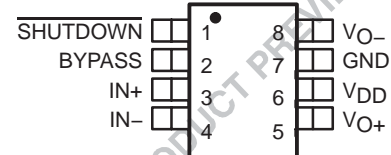

Please be aware that an important notice concerning availability, standard warranty, and use in critical applications of Texas Instruments semiconductor products and disclaimers thereto appears at the end of this data sheet.



These devices have limited built-in ESD protection. The leads should be shorted together or the device placed in conductive foam during storage or handling to prevent electrostatic damage to the MOS gates.

ORDERING INFORMATION

	PACKAGED DEVICE	
	QFN (DRB)	MSOP (DGN)
Device	TPA6204A1DRB	TPA6204A1DGN
Symbolization	AYJ	TBD

(1) The DRB is only available taped and reeled. To order taped and reeled parts, add the suffix R to the part number (TPA6204A1DRBR).

TERMINAL FUNCTIONS

TERMINAL		I/O	DESCRIPTION
NAME	DRB		
IN-	4	I	Negative differential input
IN+	3	I	Positive differential input
V _{DD}	6	I	Power supply
V _{O+}	5	O	Positive BTL output
GND	7	I	High-current ground
V _{O-}	8	O	Negative BTL output
SHUTDOWN	1	I	Shutdown terminal (active low logic)
BYPASS	2		Mid-supply voltage, adding a bypass capacitor improves PSRR
Thermal Pad	-	-	Connect to ground. Thermal pad must be soldered down in all applications to properly secure device on the PCB.

ABSOLUTE MAXIMUM RATINGS

over operating free-air temperature range unless otherwise noted⁽¹⁾

	UNIT
Supply voltage, V _{DD}	-0.3 V to 6 V
Input voltage, V _I	-0.3 V to V _{DD} + 0.3 V
Continuous total power dissipation	See Dissipation Rating Table
Operating free-air temperature, T _A	-40°C to 85°C
Junction temperature, T _J	-40°C to 150°C
Storage temperature, T _{stg}	-65°C to 85°C
Lead temperature 1,6 mm (1/16 Inch) from case for 10 seconds	DRB 260°C

(1) Stresses beyond those listed under "absolute maximum ratings" may cause permanent damage to the device. These are stress ratings only, and functional operation of the device at these or any other conditions beyond those indicated under "recommended operating conditions" is not implied. Exposure to absolute-maximum-rated conditions for extended periods may affect device reliability.

PACKAGE DISSIPATION RATINGS

PACKAGE	T _A ≤ 25°C POWER RATING	DERATING FACTOR ⁽¹⁾	T _A = 70°C POWER RATING	T _A = 85°C POWER RATING
DRB	2.7 W	21.8 mW/°C	1.7 W	1.4 W

(1) Derating factor based on high-k board layout.

RECOMMENDED OPERATING CONDITIONS

	MIN	TYP	MAX	UNIT
Supply voltage, V _{DD}	2.5		5.5	V
High-level input voltage, V _{IH}	1.55			V
Low-level input voltage, V _{IL}			0.5	V
Operating free-air temperature, T _A	-40		85	°C

ELECTRICAL CHARACTERISTICS, $T_A = 25^\circ\text{C}$

PARAMETER		TEST CONDITIONS	MIN	TYP	MAX	UNIT
V_{OS}	Output offset voltage (measured differentially)	$V_I = 0\text{ V}$ differential, Gain = 1 V/V, $V_{DD} = 5.5\text{ V}$	-9	0.3	9	mV
PSRR	Power supply rejection ratio	$V_{DD} = 2.5\text{ V}$ to 5.5 V		-85	-60	dB
V_{IC}	Common mode input range	$V_{DD} = 2.5\text{ V}$ to 5.5 V	0.5		$V_{DD}-0.8$	V
CMRR	Common mode rejection ratio	$V_{DD} = 5.5\text{ V}$, $V_{IC} = 0.5\text{ V}$ to 4.7 V		-63	-40	dB
		$V_{DD} = 2.5\text{ V}$, $V_{IC} = 0.5\text{ V}$ to 1.7 V		-63	-40	
Low-output swing		$R_L = 8\ \Omega$, Gain = 1 V/V, $V_{IN+} = V_{DD}$, $V_{IN-} = 0\text{ V}$ or $V_{IN+} = 0\text{ V}$, $V_{IN-} = V_{DD}$	$V_{DD} = 5.5\text{ V}$	0.45		V
			$V_{DD} = 3.6\text{ V}$	0.37		
			$V_{DD} = 2.5\text{ V}$	0.26	0.4	
High-output swing		$R_L = 8\ \Omega$, Gain = 1 V/V, $V_{IN+} = V_{DD}$, $V_{IN-} = 0\text{ V}$ or $V_{IN-} = V_{DD}$, $V_{IN+} = 0\text{ V}$	$V_{DD} = 5.5\text{ V}$	4.95		V
			$V_{DD} = 3.6\text{ V}$	3.18		
			$V_{DD} = 2.5\text{ V}$	2	2.13	
$ I_{IH} $	High-level input current, <u>SHUT-DOWN</u>	$V_{DD} = 5.5\text{ V}$, $V_I = 5.8\text{ V}$		58	100	μA
$ I_{IL} $	Low-level input current, <u>SHUT-DOWN</u>	$V_{DD} = 5.5\text{ V}$, $V_I = -0.3\text{ V}$		3	100	μA
I_Q	Quiescent current	$V_{DD} = 2.5\text{ V}$ to 5.5 V , no load		4	6	mA
$I_{(SD)}$	Supply current	$V(\text{SHUTDOWN}) \leq 0.5\text{ V}$, $V_{DD} = 2.5\text{ V}$ to 5.5 V , $R_L = 8\ \Omega$		0.01	1	μA
Gain		$R_L = 8\ \Omega$	$\frac{38\text{ k}\Omega}{R_I}$	$\frac{40\text{ k}\Omega}{R_I}$	$\frac{42\text{ k}\Omega}{R_I}$	V/V
	Resistance from shutdown to GND			100		k Ω

OPERATING CHARACTERISTICS, $T_A = 25^\circ\text{C}$, Gain = 1 V/V

PARAMETER		TEST CONDITIONS	MIN	TYP	MAX	UNIT
P_O	Output power	THD + N= 1%, f = 1 kHz, $R_L = 8\ \Omega$	$V_{DD} = 5\text{ V}$	1.36		W
			$V_{DD} = 3.6\text{ V}$	0.72		
			$V_{DD} = 2.5\text{ V}$	0.33		
		THD + N= 10%, f = 1 kHz, $R_L = 8\ \Omega$	$V_{DD} = 5\text{ V}$	1.7		W
			$V_{DD} = 3.6\text{ V}$	0.85		
			$V_{DD} = 2.5\text{ V}$	0.4		
THD+N	Total harmonic distortion plus noise	$V_{DD} = 5\text{ V}$, $P_O = 1\text{ W}$, $R_L = 8\ \Omega$, f = 1 kHz		0.02%		
		$V_{DD} = 3.6\text{ V}$, $P_O = 0.5\text{ W}$, $R_L = 8\ \Omega$, f = 1 kHz		0.02%		
		$V_{DD} = 2.5\text{ V}$, $P_O = 200\text{ mW}$, $R_L = 8\ \Omega$, f = 1 kHz		0.03%		
k_{SVR}	Supply ripple rejection ratio	$V_{DD} = 3.6\text{ V}$, Inputs ac-grounded with $C_i = 2\ \mu\text{F}$, $V(\text{RIPPLE}) = 200\text{ mV}_{pp}$	f = 217 Hz	-80		dB
			f = 20 Hz to 20 kHz	-70		
SNR	Signal-to-noise ratio	$V_{DD} = 5\text{ V}$, $P_O = 1\text{ W}$, $R_L = 8\ \Omega$		105		dB
V_n	Output voltage noise	$V_{DD} = 3.6\text{ V}$, f = 20 Hz to 20 kHz, Inputs ac-grounded with $C_i = 2\ \mu\text{F}$	No weighting	15		μV_{RMS}
			A weighting	12		
CMRR	Common mode rejection ratio	$V_{DD} = 3.6\text{ V}$, $V_{IC} = 1\text{ V}_{pp}$		-65		dB
R_F	Feedback resistance		38	40	44	k Ω
	Start-up time from shutdown	$V_{DD} = 3.6\text{ V}$, $C_{BYPASS} = 0.1\ \mu\text{F}$		27		ms

TYPICAL CHARACTERISTICS

TABLE OF GRAPHS

			FIGURE
P _O	Output power	vs Supply voltage	1
		vs Load resistance	2
P _D	Power dissipation	vs Output power	3
THD+N	Total harmonic distortion + noise	vs Output power	4
		vs Frequency	5
		vs Common-mode input voltage	6
K _{SVR}	Supply voltage rejection ratio	vs Frequency	7
	GSM Power supply rejection	vs Time	8
	GSM Power supply rejection	vs Frequency	9
	Closed loop gain/phase	vs Frequency	10
	Open loop gain/phase	vs Frequency	11
I _{DD}	Supply current	vs Supply voltage	12
		vs Shutdown voltage	13
	Start-up time	vs Bypass capacitor	14

OUTPUT POWER
vs
SUPPLY VOLTAGE

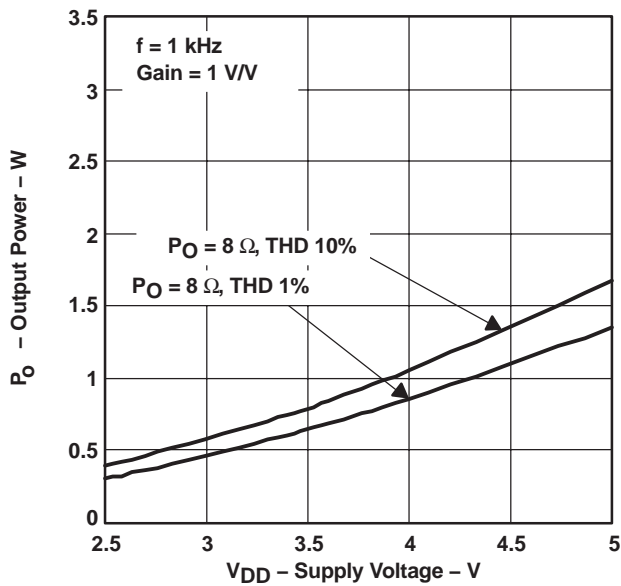

Figure 1

OUTPUT POWER
vs
LOAD RESISTANCE

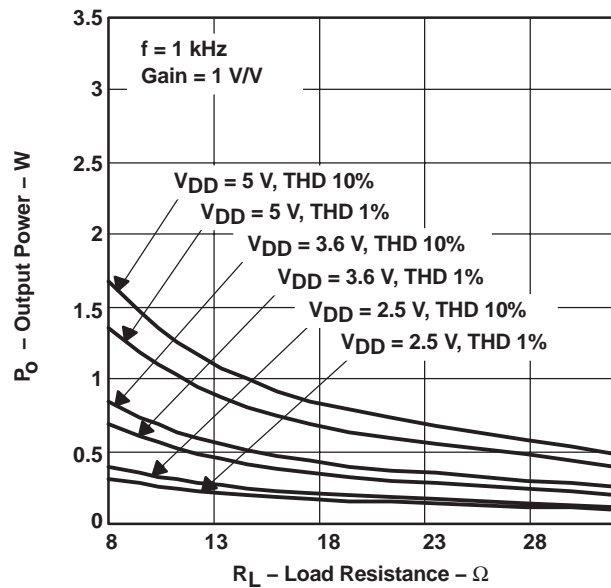

Figure 2

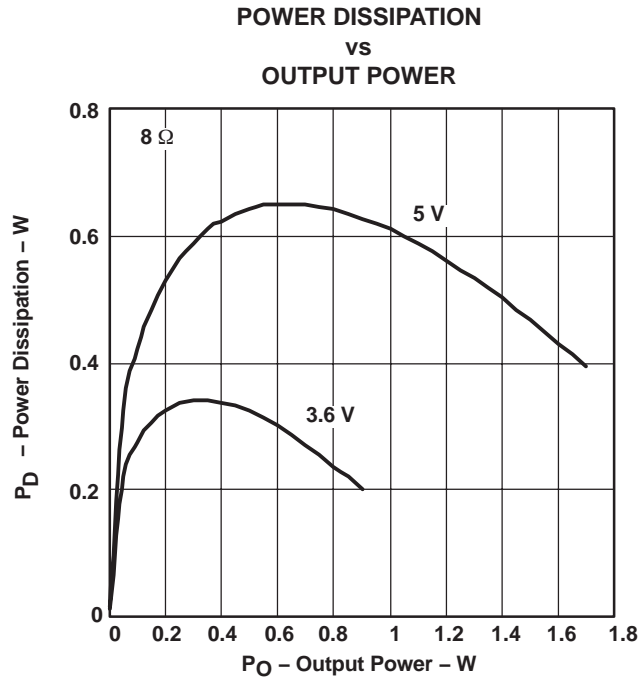

Figure 3

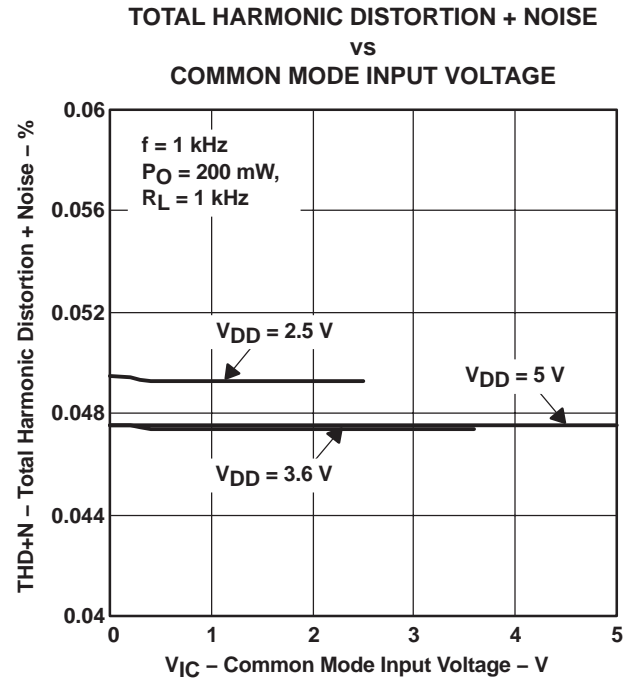

Figure 4

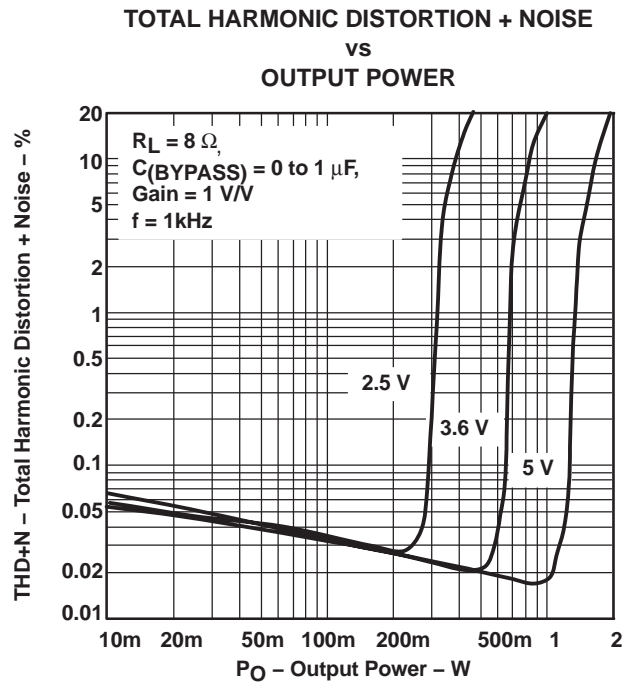

Figure 5

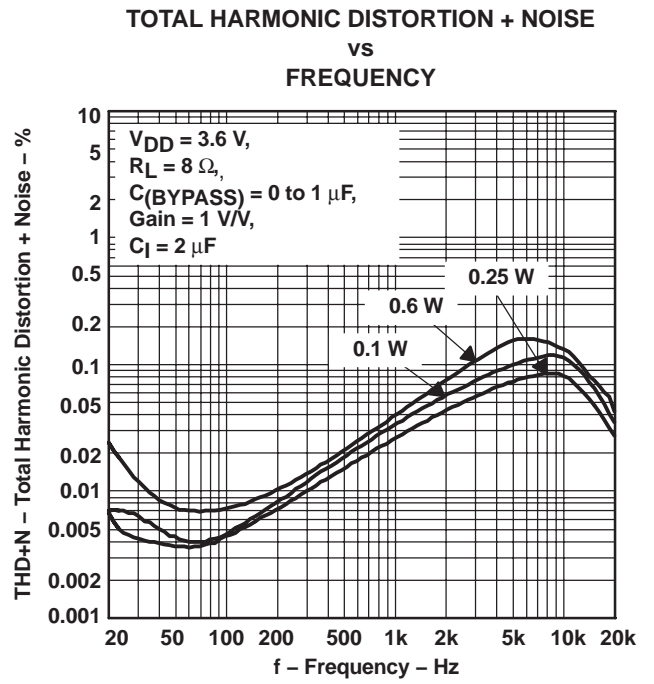

Figure 6

SUPPLY VOLTAGE REJECTION RATIO
VS
FREQUENCY

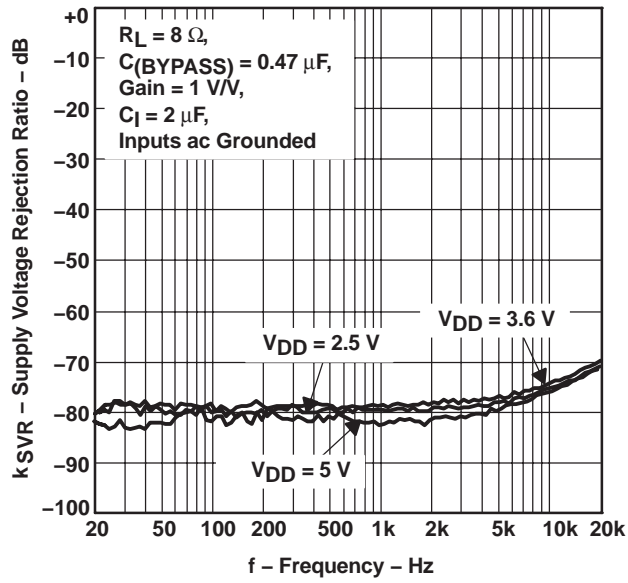

Figure 7

GSM POWER SUPPLY REJECTION
VS
FREQUENCY

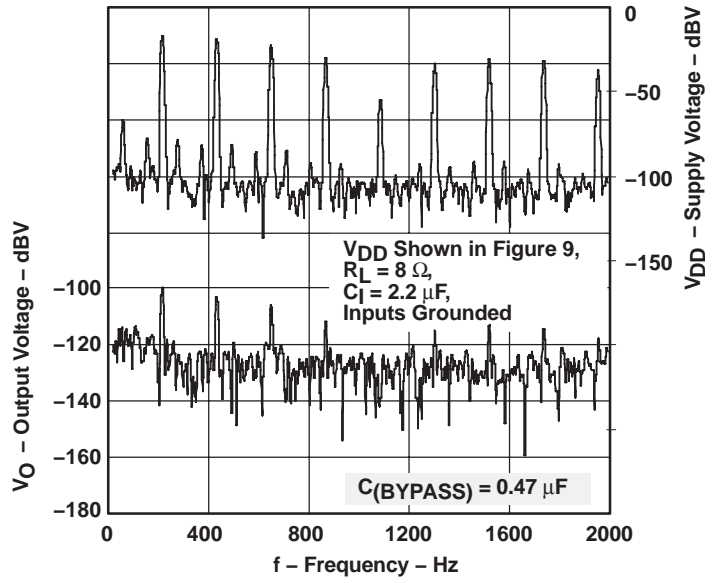

Figure 8

GSM POWER SUPPLY REJECTION
VS
TIME

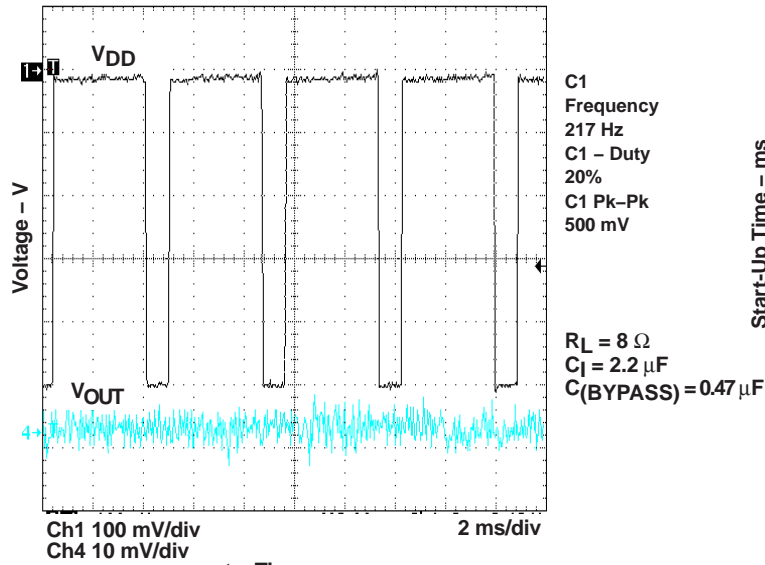

Figure 9

START-UP TIME
VS
BYPASS CAPACITOR

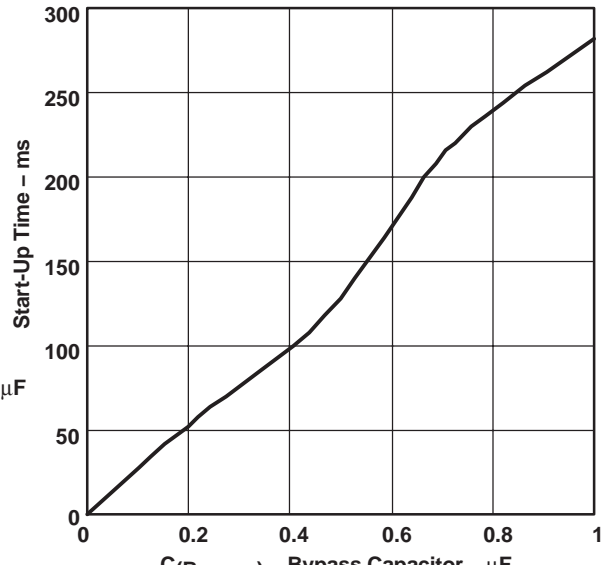

Figure 10

CLOSED LOOP GAIN/PHASE
VS
FREQUENCY

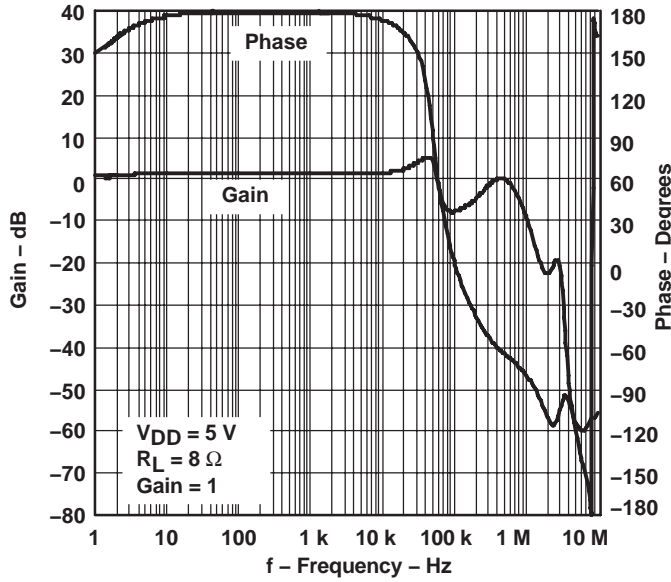

Figure 11

OPEN LOOP GAIN/PHASE
VS
FREQUENCY

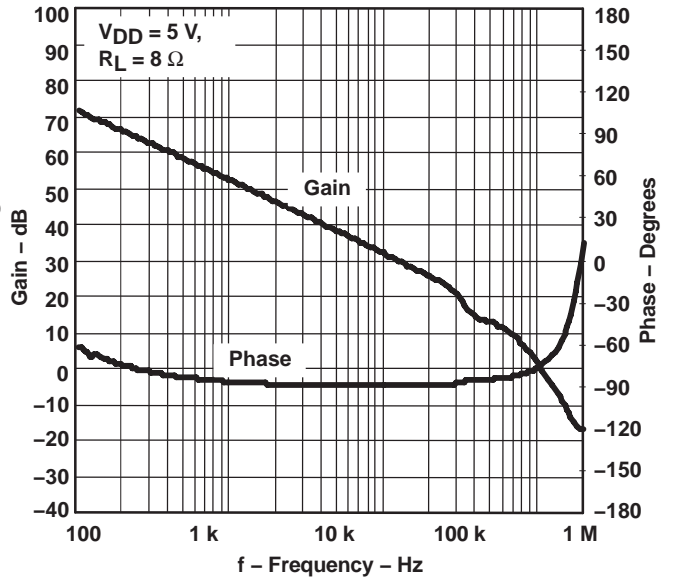

Figure 12

SUPPLY CURRENT
VS
SUPPLY VOLTAGE

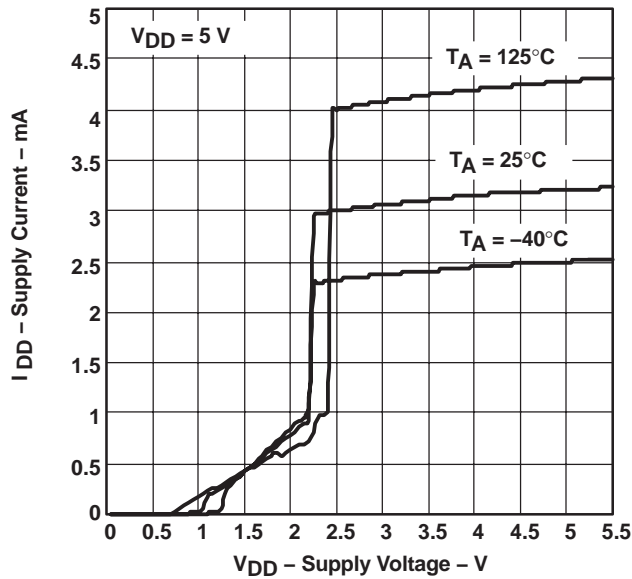

Figure 13

SUPPLY CURRENT
VS
SHUTDOWN VOLTAGE

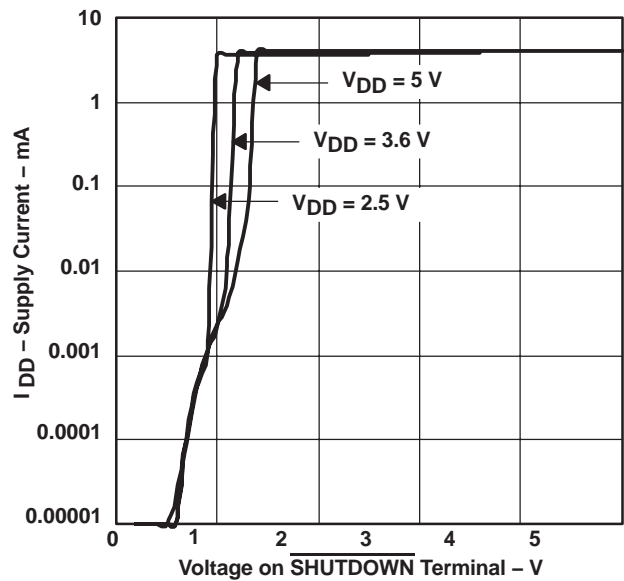

Figure 14

APPLICATION INFORMATION

FULLY DIFFERENTIAL AMPLIFIER

The TPA6204A1 is a fully differential amplifier with differential inputs and outputs. The fully differential amplifier consists of a differential amplifier and a common-mode amplifier. The differential amplifier ensures that the amplifier outputs a differential voltage that is equal to the differential input times the gain. The common-mode feedback ensures that the common-mode voltage at the output is biased around $V_{DD}/2$ regardless of the common-mode voltage at the input.

Advantages of Fully Differential Amplifiers

- **Input coupling capacitors not required:** A fully differential amplifier with good CMRR, like the TPA6204A1, allows the inputs to be biased at voltage other than mid-supply. For example, if a DAC has mid-supply lower than the mid-supply of the TPA6204A1, the common-mode feedback circuit adjusts for that, and the TPA6204A1 outputs are still biased at mid-supply of the TPA6204A1. The inputs of the TPA6204A1 can be biased from 0.5 V to $V_{DD} - 0.8$ V. If the inputs are biased outside of that range, input coupling capacitors are required.
- **Mid-supply bypass capacitor, $C_{(BYPASS)}$, not required:** The fully differential amplifier does not require a bypass capacitor. This is because any shift in the mid-supply affects both positive and negative

channels equally and cancels at the differential output. However, removing the bypass capacitor slightly worsens power supply rejection ratio (k_{SVR}), but a slight decrease of k_{SVR} may be acceptable when an additional component can be eliminated.

- **Better RF-immunity:** GSM handsets save power by turning on and shutting off the RF transmitter at a rate of 217 Hz. The transmitted signal is picked-up on input and output traces. The fully differential amplifier cancels the signal much better than the typical audio amplifier.

APPLICATION SCHEMATICS

Figure 15 through Figure 17 show application schematics for differential and single-ended inputs. Typical values are shown in Table 1.

Table 1. Typical Component Values

COMPONENT	VALUE
R_I	40 k Ω
$C_{(BYPASS)}^{(1)}$	0.22 μ F
C_S	1 μ F
C_I	0.22 μ F

(1) $C_{(BYPASS)}$ is optional

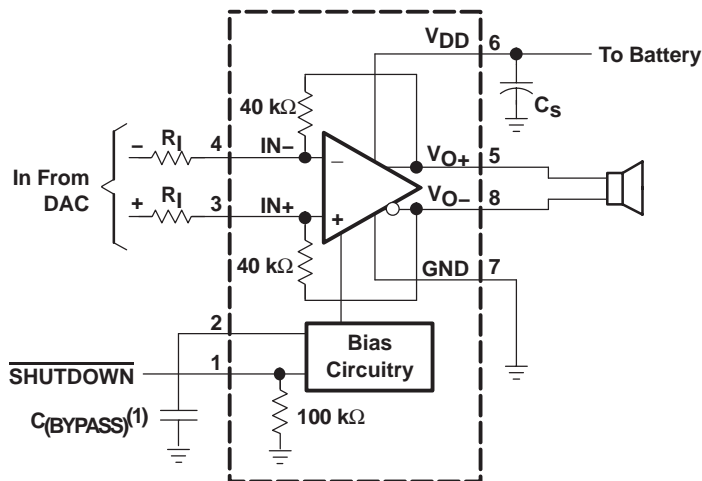

(1) $C_{(BYPASS)}$ is optional

Figure 15. Typical Differential Input Application Schematic

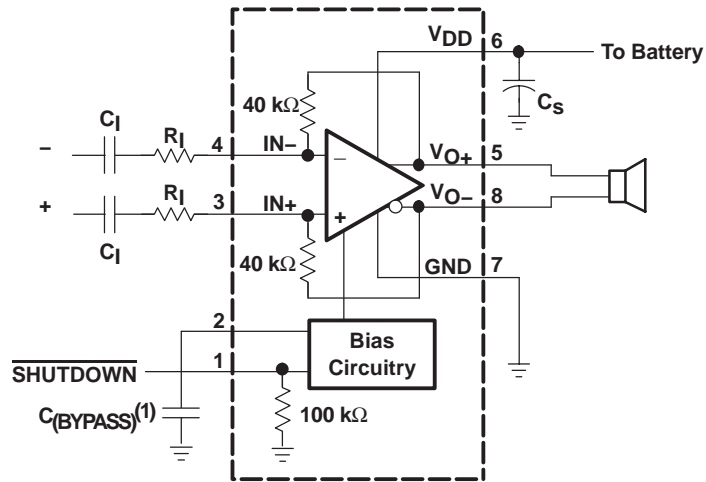

(1) $C_{(BYPASS)}$ is optional

Figure 16. Differential Input Application Schematic Optimized With Input Capacitors

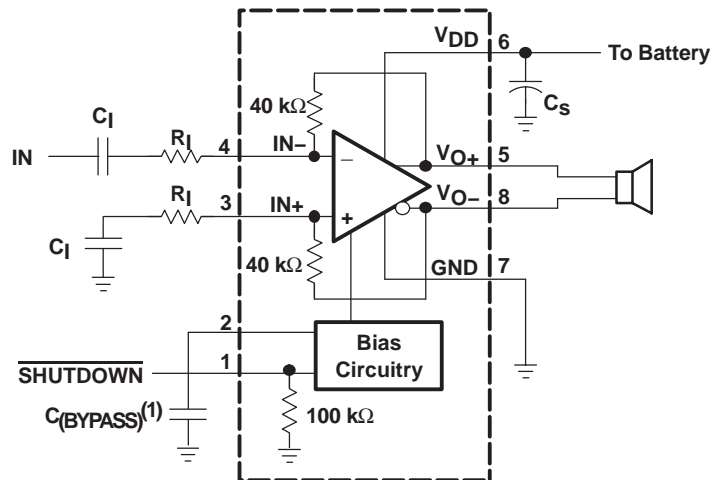

(1) $C_{(BYPASS)}$ is optional

(2) Due to the fully differential design of this amplifier, the performance is severely degraded if you connect the unused input to **BYPASS** when using single-ended inputs.

Figure 17. Single-Ended Input Application Schematic

SELECTING COMPONENTS

Resistors (R_f)

The input resistor (R_I) can be selected to set the gain of the amplifier according to equation 1.

$$\text{Gain} = R_F/R_I \quad (1)$$

The internal feedback resistors (R_F) are trimmed to 40 k Ω .

Resistor matching is very important in fully differential amplifiers. The balance of the output on the reference voltage depends on matched ratios of the resistors. CMRR, PSRR, and the cancellation of the second harmonic distortion diminishes if resistor mismatch occurs. Therefore, it is recommended to use 1% tolerance resistors or better to keep the performance optimized.

USING LOW-ESR CAPACITORS

Low-ESR capacitors are recommended throughout this applications section. A real (as opposed to ideal) capacitor can be modeled simply as a resistor in series with an ideal capacitor. The voltage drop across this resistor minimizes the beneficial effects of the capacitor in the circuit. The lower the equivalent value of this resistance the more the real capacitor behaves like an ideal capacitor.

Bypass Capacitor (C_{BYPASS}) and Start-Up Time

The internal voltage divider at the BYPASS pin of this device sets a mid-supply voltage for internal references and sets the output common mode voltage to $V_{\text{DD}}/2$. Adding a capacitor to this pin filters any noise into this pin and increases k_{SVR} . $C_{\text{(BYPASS)}}$ also determines the rise time of $V_{\text{O+}}$ and $V_{\text{O-}}$ when the device is taken out of shutdown. The larger the capacitor, the slower the rise time. NO TAGNO TAGNO TAGNO TAGNO TAG show the relationship of $C_{\text{(BYPASS)}}$ to start-up time.

Input Capacitor (C_I)

The TPA6204A1 does not require input coupling capacitors if using a differential input source that is biased from 0.5 V to $V_{\text{DD}} - 0.8$ V. Use 1% tolerance or better gain-setting resistors if not using input coupling capacitors.

In the single-ended input application an input capacitor, C_I , is required to allow the amplifier to bias the input signal to the proper dc level. In this case, C_I and R_I form a high-pass filter with the corner frequency determined in equation 2.

$$f_c = \frac{1}{2\pi R_I C_I} \quad (2)$$

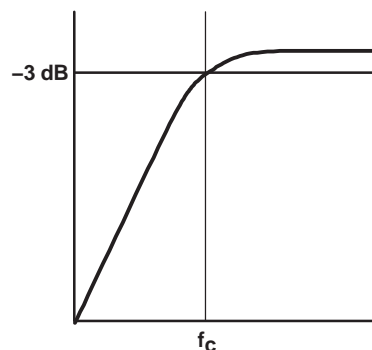

The value of C_I is important to consider as it directly affects the bass (low frequency) performance of the circuit. Consider the example where R_I is 10 k Ω and the specification calls for a flat bass response down to 100 Hz. Equation 2 is reconfigured as equation 3.

$$C_I = \frac{1}{2\pi R_I f_c} \quad (3)$$

In this example, C_I is 0.16 μF , so one would likely choose a value in the range of 0.22 μF to 0.47 μF . Ceramic capacitors should be used when possible, as they are the best choice in preventing leakage current. When polarized capacitors are used, the positive side of the capacitor should face the amplifier input in most applications, as the dc level there is held at $V_{\text{DD}}/2$, which is likely higher than the source dc level. It is important to confirm the capacitor polarity in the application.

Decoupling Capacitor (C_S)

The TPA6204A1 is a high-performance CMOS audio amplifier that requires adequate power supply decoupling to ensure the output total harmonic distortion (THD) is as low as possible. Power supply decoupling also prevents oscillations for long lead lengths between the amplifier and the speaker. For higher frequency transients, spikes, or digital hash on the line, a good low equivalent-series-resistance (ESR) ceramic capacitor, typically 0.1 μF to 1 μF , placed as close as possible to the device V_{DD} lead works best. For filtering lower frequency noise signals, a 10- μF or greater capacitor placed near the audio power amplifier also helps, but is not required in most applications because of the high PSRR of this device.

FULLY DIFFERENTIAL AMPLIFIER EFFICIENCY AND THERMAL INFORMATION

Class-AB amplifiers are inefficient. The primary cause of these inefficiencies is voltage drop across the output stage transistors. There are two components of the internal voltage drop. One is the headroom or dc voltage drop that varies inversely to output power. The second component is due to the sinewave nature of the output. The total voltage drop can be calculated by subtracting the RMS value of the output voltage from V_{DD} . The internal voltage drop multiplied by the average value of the supply current, $I_{DD(avg)}$, determines the internal power dissipation of the amplifier.

An easy-to-use equation to calculate efficiency starts out as being equal to the ratio of power from the power supply to the power delivered to the load. To accurately calculate the RMS and average values of power in the load and in the amplifier, the current and voltage waveform shapes must first be understood (see Figure 18).

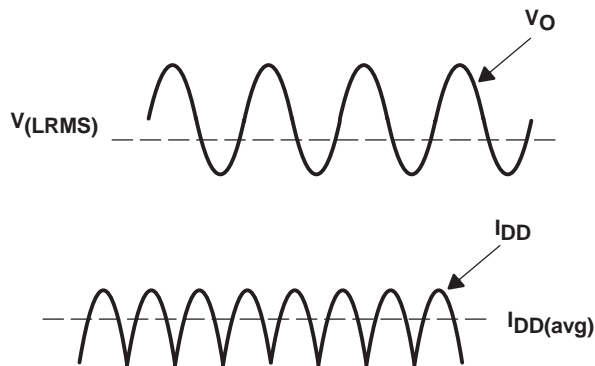

Figure 18. Voltage and Current Waveforms for BTL Amplifiers

Although the voltages and currents for SE and BTL are sinusoidal in the load, currents from the supply are different between SE and BTL configurations. In an SE application the current waveform is a half-wave rectified shape, whereas in BTL it is a full-wave rectified waveform. This means RMS conversion factors are different. Keep in mind that for most of the waveform both the push and pull transistors are not on at the same time, which supports the fact that each amplifier in the BTL device only draws current from the supply for half the waveform. The following equations are the basis for calculating amplifier efficiency.

$$\text{Efficiency of a BTL amplifier} = \frac{P_L}{P_{SUP}} \quad (4)$$

Where:

$$P_L = \frac{V_{Lrms}^2}{R_L}, \text{ and } V_{LRMS} = \frac{V_P}{\sqrt{2}}, \text{ therefore, } P_L = \frac{V_P^2}{2R_L}$$

$$\text{and } P_{SUP} = V_{DD} I_{DDavg} \text{ and } I_{DDavg} = \frac{1}{\pi} \int_0^{\pi} \frac{V_P}{R_L} \sin(t) dt = -\frac{1}{\pi} \times \frac{V_P}{R_L} [\cos(t)]_0^{\pi} = \frac{2V_P}{\pi R_L}$$

Therefore,

$$P_{SUP} = \frac{2V_{DD} V_P}{\pi R_L}$$

substituting P_L and P_{SUP} into equation 6,

$$\text{Efficiency of a BTL amplifier} = \frac{\frac{V_P^2}{2R_L}}{\frac{2V_{DD} V_P}{\pi R_L}} = \frac{\pi V_P}{4V_{DD}}$$

Where:

$$V_P = \sqrt{2 P_L R_L}$$

Therefore,

$$\eta_{BTL} = \frac{\pi \sqrt{2 P_L R_L}}{4 V_{DD}}$$

P_L = Power delivered to load
 P_{SUP} = Power drawn from power supply
 V_{LRMS} = RMS voltage on BTL load
 R_L = Load resistance
 V_P = Peak voltage on BTL load
 I_{DDavg} = Average current drawn from the power supply
 V_{DD} = Power supply voltage
 η_{BTL} = Efficiency of a BTL amplifier

(5)

Table 2 and Table 3 employ equation (5) to calculate efficiencies for four different output power levels. Note that the efficiency of the amplifier is quite low for lower power levels and rises sharply as power to the load is increased resulting in a nearly flat internal power dissipation over the normal operating range. Note that the internal dissipation at full output power is less than in the half power range. Calculating the efficiency for a specific system is the key to proper power supply design. For a 1-W audio system with 8-Ω loads and a 5-V supply, the maximum draw on the power supply is almost 1.6 W.

A final point to remember about Class-AB amplifiers is how to manipulate the terms in the efficiency equation to the utmost advantage when possible.

A simple formula for calculating the maximum power dissipated, P_{Dmax} , may be used for a differential output application:

$$P_{Dmax} = \frac{2V_{DD}^2}{\pi^2 R_L} \quad (6)$$

P_{Dmax} for a 5-V, 8-Ω system is 0.64 W.

The maximum ambient temperature depends on the heat sinking ability of the PCB system. The derating factor for the 3 mm x 3 mm DRB package is shown in the dissipation rating table. Converting this to Θ_{JA} :

$$\Theta_{JA} = \frac{1}{\text{Derating Factor}} = \frac{1}{0.0218} = 45.9^\circ\text{C/W} \quad (7)$$

Given Θ_{JA} , the maximum allowable junction temperature, and the maximum internal dissipation, the maximum ambient temperature can be calculated with the following equation. The maximum recommended junction temperature for the TPA6204A1 is 150°C.

$$T_A \text{ Max} = T_J \text{ Max} - \Theta_{JA} P_{Dmax} \quad (8)$$

$$= 150 - 45.9(0.64) = 120.6^\circ\text{C}$$

Equation (8) shows that the maximum ambient temperature is 120.6°C (package limited to 85°C) at maximum power dissipation with a 5-V supply.

Table 2 shows that for most applications no airflow is required to keep junction temperatures in the specified range. The TPA6204A1 is designed with thermal protection that turns the device off when the junction temperature surpasses 150°C to prevent damage to the IC. In addition, using speakers with an impedance higher than 8-Ω dramatically increases the thermal performance by reducing the output current.

Table 2. Efficiency and Maximum Ambient Temperature vs Output Power in 3.6-V 8-Ω BTL Systems

Output Power (W)	Efficiency (%)	Internal Dissipation (W)	Power From Supply (W)	Max Ambient Temperature ⁽²⁾ (°C)
0.1	27.6	0.262	0.36	85
0.2	39.0	0.312	0.51	85
0.5	61.7	0.310	0.81	85
0.6	67.6	0.288	0.89	85

- (1) DRB package
- (2) Package limited to 85°C ambient

Table 3. Efficiency and Maximum Ambient Temperature vs Output Power in 5-V 8-Ω Systems

Output Power (W)	Efficiency (%)	Internal Dissipation (W)	Power From Supply (W)	Max Ambient Temperature ⁽²⁾ (°C)
0.5	44.4	0.625	1.13	85
1	62.8	0.592	1.60	85
1.36	73.3	0.496	1.86	85
1.7	81.9	0.375	2.08	85

- (1) DRB package
- (2) Package limited to 85°C ambient

PCB LAYOUT

It is important to keep the TPA6204A1 external components very close to the TPA6204A1 to limit noise pickup.

8-Pin QFN (DRB) Layout

Use the following land pattern for board layout with the 8-pin QFN (DRB) package. Note that the solder paste should use a hatch pattern to fill solder paste at 50% to ensure that there is not too much solder paste under the package.

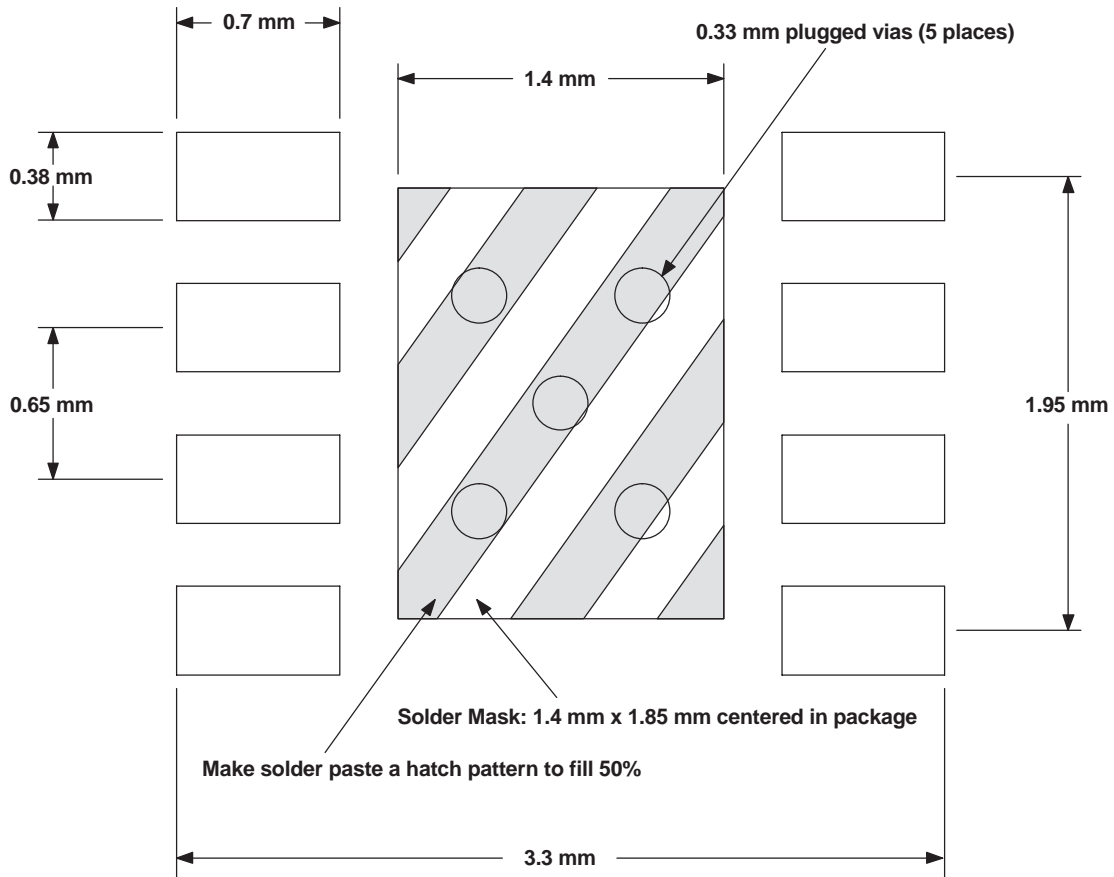

Figure 19. TPA6204A1 8-Pin QFN (DRB) Board Layout (Top View)

PACKAGING INFORMATION

Orderable Device	Status ⁽¹⁾	Package Type	Package Drawing	Pins	Package Qty	Eco Plan ⁽²⁾	Lead/Ball Finish	MSL Peak Temp ⁽³⁾
TPA6204A1DRB	ACTIVE	SON	DRB	8	121	Green (RoHS & no Sb/Br)	CU NIPDAU	Level-2-260C-1 YEAR
TPA6204A1DRBR	ACTIVE	SON	DRB	8	3000	Green (RoHS & no Sb/Br)	CU NIPDAU	Level-2-260C-1 YEAR
TPA6204A1DRBRG4	ACTIVE	SON	DRB	8	3000	Green (RoHS & no Sb/Br)	CU NIPDAU	Level-2-260C-1 YEAR

⁽¹⁾ The marketing status values are defined as follows:

ACTIVE: Product device recommended for new designs.

LIFEBUY: TI has announced that the device will be discontinued, and a lifetime-buy period is in effect.

NRND: Not recommended for new designs. Device is in production to support existing customers, but TI does not recommend using this part in a new design.

PREVIEW: Device has been announced but is not in production. Samples may or may not be available.

OBsolete: TI has discontinued the production of the device.

⁽²⁾ Eco Plan - May not be currently available - please check <http://www.ti.com/productcontent> for the latest availability information and additional product content details.

None: Not yet available Lead (Pb-Free).

Pb-Free (RoHS): TI's terms "Lead-Free" or "Pb-Free" mean semiconductor products that are compatible with the current RoHS requirements for all 6 substances, including the requirement that lead not exceed 0.1% by weight in homogeneous materials. Where designed to be soldered at high temperatures, TI Pb-Free products are suitable for use in specified lead-free processes.

Green (RoHS & no Sb/Br): TI defines "Green" to mean "Pb-Free" and in addition, uses package materials that do not contain halogens, including bromine (Br) or antimony (Sb) above 0.1% of total product weight.

⁽³⁾ MSL, Peak Temp. -- The Moisture Sensitivity Level rating according to the JEDEC industry standard classifications, and peak solder temperature.

Important Information and Disclaimer: The information provided on this page represents TI's knowledge and belief as of the date that it is provided. TI bases its knowledge and belief on information provided by third parties, and makes no representation or warranty as to the accuracy of such information. Efforts are underway to better integrate information from third parties. TI has taken and continues to take reasonable steps to provide representative and accurate information but may not have conducted destructive testing or chemical analysis on incoming materials and chemicals. TI and TI suppliers consider certain information to be proprietary, and thus CAS numbers and other limited information may not be available for release.

In no event shall TI's liability arising out of such information exceed the total purchase price of the TI part(s) at issue in this document sold by TI to Customer on an annual basis.

DRB (S-PDSO-N8)

PLASTIC SMALL OUTLINE

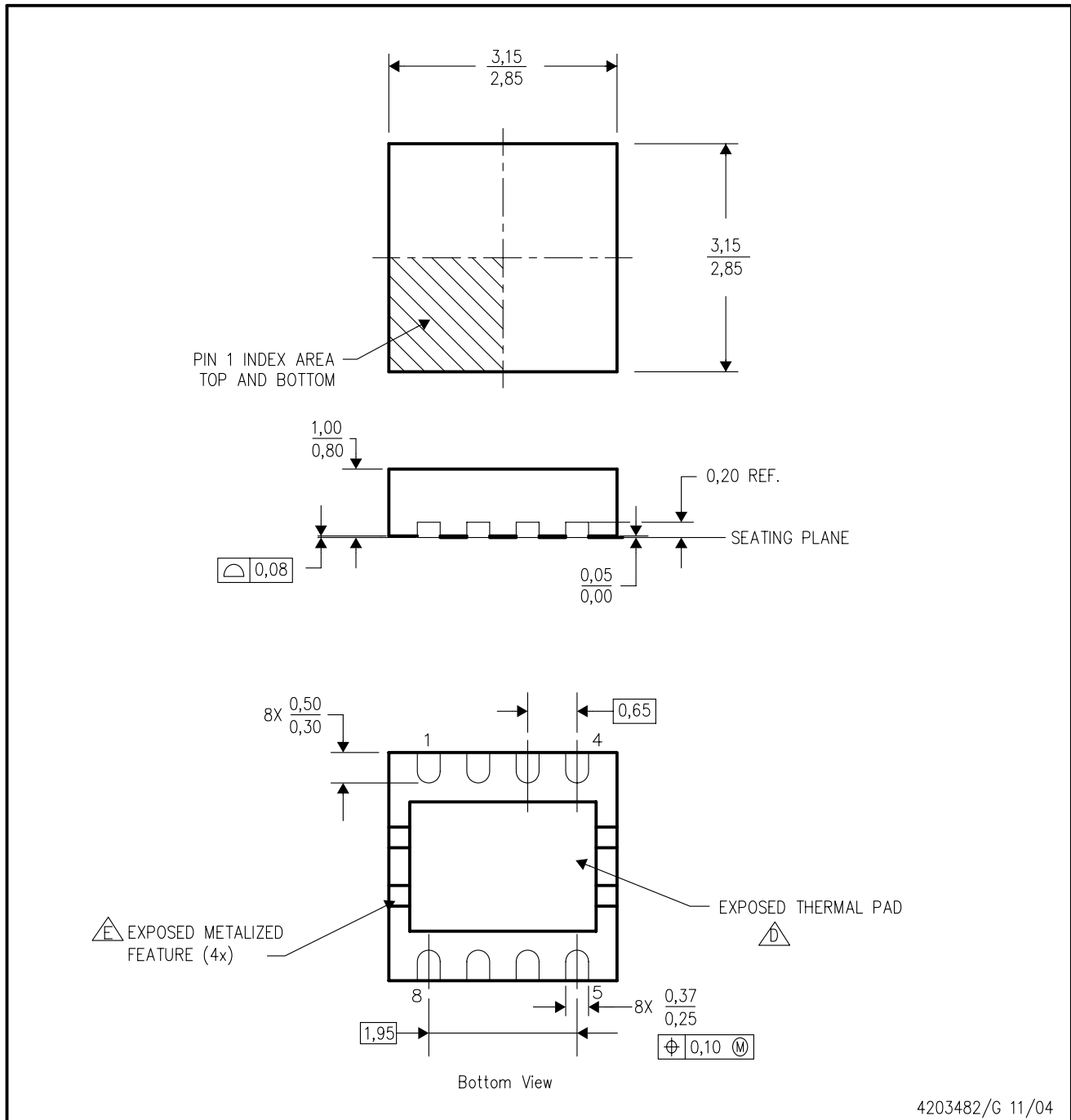

4203482/G 11/04

- NOTES:
- A. All linear dimensions are in millimeters. Dimensioning and tolerancing per ASME Y14.5M-1994.
 - B. This drawing is subject to change without notice.
 - C. Small Outline No-Lead (SON) package configuration.
 - \triangle The package thermal pad must be soldered to the board for thermal and mechanical performance. See the Product Data Sheet for details regarding the exposed thermal pad dimensions.
 - \triangle Metalized features are supplier options and may not be on the package.

IMPORTANT NOTICE

Texas Instruments Incorporated and its subsidiaries (TI) reserve the right to make corrections, modifications, enhancements, improvements, and other changes to its products and services at any time and to discontinue any product or service without notice. Customers should obtain the latest relevant information before placing orders and should verify that such information is current and complete. All products are sold subject to TI's terms and conditions of sale supplied at the time of order acknowledgment.

TI warrants performance of its hardware products to the specifications applicable at the time of sale in accordance with TI's standard warranty. Testing and other quality control techniques are used to the extent TI deems necessary to support this warranty. Except where mandated by government requirements, testing of all parameters of each product is not necessarily performed.

TI assumes no liability for applications assistance or customer product design. Customers are responsible for their products and applications using TI components. To minimize the risks associated with customer products and applications, customers should provide adequate design and operating safeguards.

TI does not warrant or represent that any license, either express or implied, is granted under any TI patent right, copyright, mask work right, or other TI intellectual property right relating to any combination, machine, or process in which TI products or services are used. Information published by TI regarding third-party products or services does not constitute a license from TI to use such products or services or a warranty or endorsement thereof. Use of such information may require a license from a third party under the patents or other intellectual property of the third party, or a license from TI under the patents or other intellectual property of TI.

Reproduction of information in TI data books or data sheets is permissible only if reproduction is without alteration and is accompanied by all associated warranties, conditions, limitations, and notices. Reproduction of this information with alteration is an unfair and deceptive business practice. TI is not responsible or liable for such altered documentation.

Resale of TI products or services with statements different from or beyond the parameters stated by TI for that product or service voids all express and any implied warranties for the associated TI product or service and is an unfair and deceptive business practice. TI is not responsible or liable for any such statements.

Following are URLs where you can obtain information on other Texas Instruments products and application solutions:

Products		Applications	
Amplifiers	amplifier.ti.com	Audio	www.ti.com/audio
Data Converters	dataconverter.ti.com	Automotive	www.ti.com/automotive
DSP	dsp.ti.com	Broadband	www.ti.com/broadband
Interface	interface.ti.com	Digital Control	www.ti.com/digitalcontrol
Logic	logic.ti.com	Military	www.ti.com/military
Power Mgmt	power.ti.com	Optical Networking	www.ti.com/opticalnetwork
Microcontrollers	microcontroller.ti.com	Security	www.ti.com/security
		Telephony	www.ti.com/telephony
		Video & Imaging	www.ti.com/video
		Wireless	www.ti.com/wireless

Mailing Address: Texas Instruments
Post Office Box 655303 Dallas, Texas 75265