

TPIC6C596 POWER LOGIC 8-BIT SHIFT REGISTER

SLIS093B – MARCH 2000 – REVISED MAY 2004

- Low $r_{DS(on)}$. . . 7 Ω Typ
- Avalanche Energy . . . 30 mJ
- Eight Power DMOS Transistor Outputs of 100-mA Continuous Current
- 250-mA Current Limit Capability
- ESD Protection . . . 2500 V
- Output Clamp Voltage . . . 33 V
- Enhanced Cascading for Multiple Stages
- All Registers Cleared With Single Input
- Low Power Consumption

D OR N PACKAGE
(TOP VIEW)

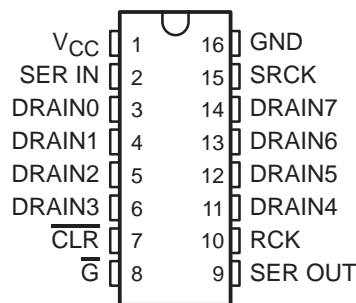

description

The TPIC6C596 is a monolithic, medium-voltage, low-current power 8-bit shift register designed for use in systems that require relatively moderate load power such as LEDs. The device contains a built-in voltage clamp on the outputs for inductive transient protection. Power driver applications include relays, solenoids, and other low-current or medium-voltage loads.

This device contains an 8-bit serial-in, parallel-out shift register that feeds an 8-bit D-type storage register. Data transfers through both the shift and storage registers on the rising edge of the shift register clock (SRCK) and the register clock (RCK), respectively. The storage register transfers data to the output buffer when shift register clear (CLR) is high. When CLR is low, all registers in the device are cleared. When output enable (\bar{G}) is held high, all data in the output buffers is held low and all drain outputs are off. When \bar{G} is held low, data from the storage register is transparent to the output buffers. When data in the output buffers is low, the DMOS transistor outputs are off. When data is high, the DMOS transistor outputs have sink-current capability. The serial output (SER OUT) is clocked out of the device on the falling edge of SRCK to provide additional hold time for cascaded applications. This will provide improved performance for applications where clock signals may be skewed, devices are not located near one another, or the system must tolerate electromagnetic interference.

logic symbol†

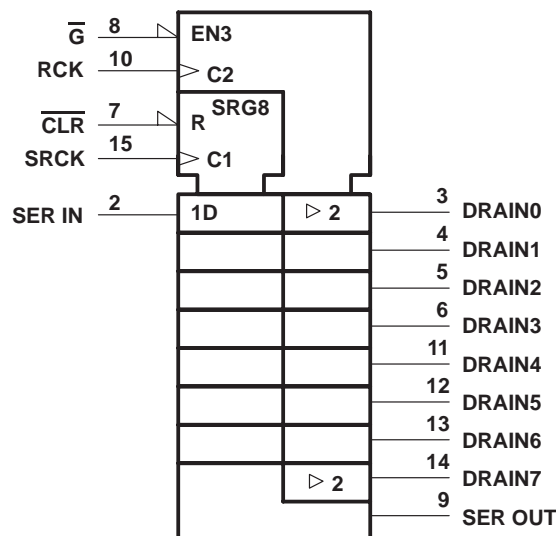

† This symbol is in accordance with ANSI/IEEE Std 91-1984 and IEC Publication 617-12.



This device contains circuits to protect its inputs and outputs against damage due to high static voltages or electrostatic fields. These circuits have been qualified to protect this device against electrostatic discharges (ESD) of up to 2 kV according to MIL-STD-883C, Method 3015; however, it is advised that precautions be taken to avoid application of any voltage higher than maximum-rated voltages to these high-impedance circuits. During storage or handling, the device leads should be shorted together or the device should be placed in conductive foam. In a circuit, unused inputs should always be connected to an appropriated logic voltage level, preferably either V_{CC} or ground. Specific guidelines for handling devices of this type are contained in the publication *Guidelines for Handling Electrostatic-Discharge-Sensitive (ESDS) Devices and Assemblies* available from Texas Instruments.



Please be aware that an important notice concerning availability, standard warranty, and use in critical applications of Texas Instruments semiconductor products and disclaimers thereto appears at the end of this data sheet.

PRODUCTION DATA information is current as of publication date. Products conform to specifications per the terms of Texas Instruments standard warranty. Production processing does not necessarily include testing of all parameters.

 **TEXAS
INSTRUMENTS**

POST OFFICE BOX 655303 • DALLAS, TEXAS 75265

Copyright © 2000–2004, Texas Instruments Incorporated

TPIC6C596 POWER LOGIC 8-BIT SHIFT REGISTER

SLIS093B – MARCH 2000 – REVISED MAY 2004

description (continued)

Outputs are low-side, open-drain DMOS transistors with output ratings of 33 V and 100 mA continuous sink-current capability. Each output provides a 250-mA maximum current limit at $T_C = 25^\circ\text{C}$. The current limit decreases as the junction temperature increases for additional device protection. The device also provides up to 2500 V of ESD protection when tested using the human-body model and the 200-V machine model.

The TPIC6C596 is characterized for operation over the operating case temperature range of -40°C to 125°C .

logic diagram (positive logic)

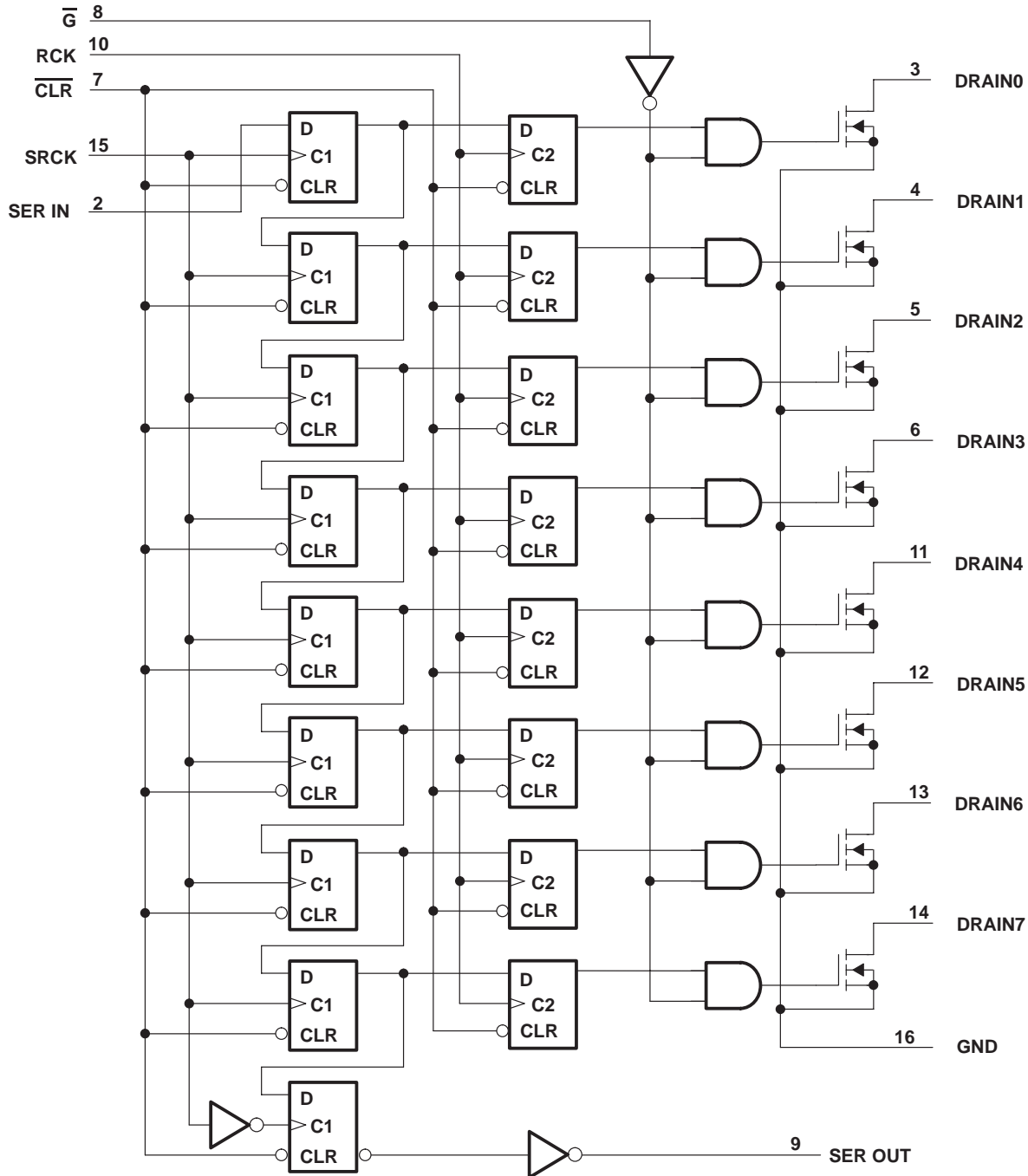

schematic of inputs and outputs

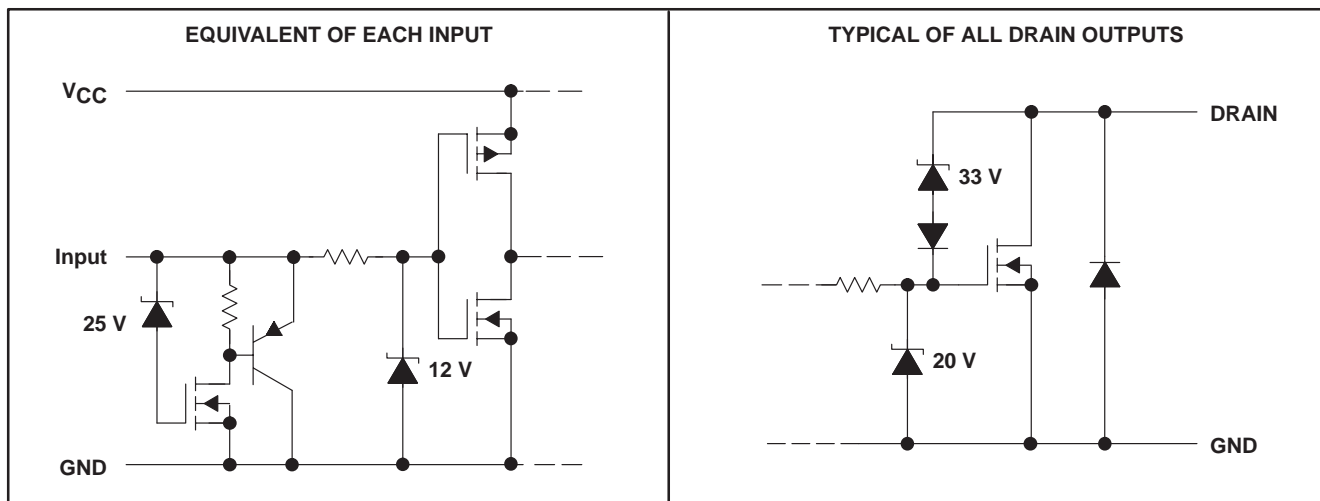

absolute maximum ratings over recommended operating case temperature range (unless otherwise noted)†

Logic supply voltage, V_{CC} (see Note 1)	7 V
Logic input voltage range, V_I	-0.3 V to 7 V
Power DMOS drain-to-source voltage, V_{DS} (see Note 2)	33 V
Continuous source-to-drain diode anode current	250 mA
Pulsed source-to-drain diode anode current (see Note 3)	500 mA
Pulsed drain current, each output, all outputs on, I_D , $T_C = 25^\circ\text{C}$ (see Note 3)	250 mA
Continuous drain current, each output, all outputs on, I_D , $T_C = 25^\circ\text{C}$	100 mA
Peak drain current single output, I_{DM} , $T_C = 25^\circ\text{C}$ (see Note 3)	250 mA
Single-pulse avalanche energy, E_{AS} (see Figure 4)	30 mJ
Avalanche current, I_{AS} (see Note 4)	200 mA
Continuous total dissipation	See Dissipation Rating Table
Operating virtual junction temperature range, T_J	-40°C to 150°C
Operating case temperature range, T_C	-40°C to 125°C
Storage temperature range, T_{stg}	-65°C to 150°C
Lead temperature 1,6 mm (1/16 inch) from case for 10 seconds	260°C

† Stresses beyond those listed under “absolute maximum ratings” may cause permanent damage to the device. These are stress ratings only, and functional operation of the device at these or any other conditions beyond those indicated under “recommended operating conditions” is not implied. Exposure to absolute-maximum-rated conditions for extended periods may affect device reliability.

- NOTES:
1. All voltage values are with respect to GND.
 2. Each power DMOS source is internally connected to GND.
 3. Pulse duration $\leq 100 \mu\text{s}$ and duty cycle $\leq 2\%$.
 4. DRAIN supply voltage = 15 V, starting junction temperature (T_{JS}) = 25°C, $L = 1.5 \text{ H}$, $I_{AS} = 200 \text{ mA}$ (see Figure 4).

DISSIPATION RATING TABLE

PACKAGE	$T_C \leq 25^\circ\text{C}$ POWER RATING	DERATING FACTOR ABOVE $T_C = 25^\circ\text{C}$	$T_C = 125^\circ\text{C}$ POWER RATING
D	1087 mW	8.7 mW/°C	217 mW
N	1470 mW	11.7 mW/°C	294 mW

TPIC6C596

POWER LOGIC 8-BIT SHIFT REGISTER

SLIS093B – MARCH 2000 – REVISED MAY 2004

recommended operating conditions

	MIN	MAX	UNIT
Logic supply voltage, V_{CC}	4.5	5.5	V
High-level input voltage, V_{IH}	0.85 V_{CC}		V
Low-level input voltage, V_{IL}	0.15 V_{CC}		V
Pulsed drain output current, $T_C = 25^\circ\text{C}$, $V_{CC} = 5\text{ V}$, all outputs on (see Notes 3 and 5 and Figure 11)	250		mA
Setup time, SER IN high before SRCK \uparrow , t_{SU} (see Figure 2)	15		ns
Hold time, SER IN high after SRCK \uparrow , t_H (see Figure 2)	15		ns
Pulse duration, t_W (see Figure 2)	40		ns
Operating case temperature, T_C	-40	125	$^\circ\text{C}$

NOTES: 3. Pulse duration $\leq 100\ \mu\text{s}$ and duty cycle $\leq 2\%$.
5. Technique should limit $T_J - T_C$ to 10°C maximum.

electrical characteristics, $V_{CC} = 5\text{ V}$, $T_C = 25^\circ\text{C}$ (unless otherwise noted)

PARAMETER	TEST CONDITIONS	MIN	TYP	MAX	UNIT
$V_{(BR)DSX}$ Drain-to-source breakdown voltage	$I_D = 1\text{ mA}$	33	37		V
V_{SD} Source-to-drain diode forward voltage	$I_F = 100\text{ mA}$		0.85	1.2	V
V_{OH} High-level output voltage, SER OUT	$I_{OH} = -20\ \mu\text{A}$, $V_{CC} = 4.5\text{ V}$	4.4	4.49		V
	$I_{OH} = -4\text{ mA}$, $V_{CC} = 4.5\text{ V}$	4	4.2		
V_{OL} Low-level output voltage, SER OUT	$I_{OL} = 20\ \mu\text{A}$, $V_{CC} = 4.5\text{ V}$		0.005	0.1	V
	$I_{OL} = 4\text{ mA}$, $V_{CC} = 4.5\text{ V}$		0.3	0.5	
I_{IH} High-level input current	$V_{CC} = 5.5\text{ V}$, $V_I = V_{CC}$			1	μA
I_{IL} Low-level input current	$V_{CC} = 5.5\text{ V}$, $V_I = 0$			-1	μA
I_{CC} Logic supply current	$V_{CC} = 5.5\text{ V}$	All outputs off	20	200	μA
		All outputs on	150	500	
$I_{CC}(\text{FRQ})$ Logic supply current at frequency	$f_{SRCK} = 5\text{ MHz}$, $C_L = 30\text{ pF}$, All outputs off, See Figures 2 and 6		1.2	5	mA
I_N Nominal current	$V_{DS(\text{on})} = 0.5\text{ V}$, $T_C = 85^\circ\text{C}$, $I_N = I_D$, See Notes 5, 6 and 7		90		mA
I_{DSX} Off-state drain current	$V_{DS} = 30\text{ V}$, $V_{CC} = 5.5\text{ V}$		0.1	0.2	μA
	$V_{DS} = 30\text{ V}$, $T_C = 125^\circ\text{C}$, $V_{CC} = 5.5\text{ V}$		0.15	0.3	
$r_{DS(\text{on})}$ Static drain-source on-state resistance	$I_D = 50\text{ mA}$, $V_{CC} = 4.5\text{ V}$		6.5	9	Ω
	$I_D = 50\text{ mA}$, $T_C = 125^\circ\text{C}$, $V_{CC} = 4.5\text{ V}$	See Notes 5 and 6 and Figures 7 and 8	9.9	12	
	$I_D = 100\text{ mA}$, $V_{CC} = 4.5\text{ V}$		6.8	10	

NOTES: 5. Technique should limit $T_J - T_C$ to 10°C maximum.
6. These parameters are measured with voltage-sensing contacts separate from the current-carrying contacts.
7. Nominal current is defined for a consistent comparison between devices from different sources. It is the current that produces a voltage drop of 0.5 V at $T_C = 85^\circ\text{C}$.

switching characteristics, $V_{CC} = 5\text{ V}$, $T_C = 25^\circ\text{C}$

PARAMETER		TEST CONDITIONS	MIN	TYP	MAX	UNIT
t_{PLH}	Propagation delay time, low-to-high-level output from \overline{G}	$C_L = 30\text{ pF}$, $I_D = 75\text{ mA}$, See Figures 1, 2, and 9		80		ns
t_{PHL}	Propagation delay time, high-to-low-level output from \overline{G}			50		ns
t_r	Rise time, drain output			100		ns
t_f	Fall time, drain output			80		ns
t_{pd}	Propagation delay time, SRCK \downarrow to SEROUT	$C_L = 30\text{ pF}$, See Figure 2		15		ns
$f(\text{SRCK})$	Serial clock frequency	$C_L = 30\text{ pF}$, See Note 8			10	MHz
t_a	Reverse-recovery-current rise time	$I_F = 100\text{ mA}$, $di/dt = 10\text{ A}/\mu\text{s}$,		100		ns
t_{rr}	Reverse-recovery time	See Notes 5 and 6 and Figure 3		120		

- NOTES: 5. Technique should limit $T_J - T_C$ to 10°C maximum.
 6. These parameters are measured with voltage-sensing contacts separate from the current-carrying contacts.
 8. This is the maximum serial clock frequency assuming cascaded operation where serial data is passed from one stage to a second stage. The clock period allows for SRCK \rightarrow SEROUT propagation delay and setup time plus some timing margin.

thermal resistance

PARAMETER		TEST CONDITIONS	MIN	MAX	UNIT
$R_{\theta JA}$	Thermal resistance, junction-to-ambient	D package		115	$^\circ\text{C}/\text{W}$
		N package	All 8 outputs with equal power	85	

PARAMETER MEASUREMENT INFORMATION

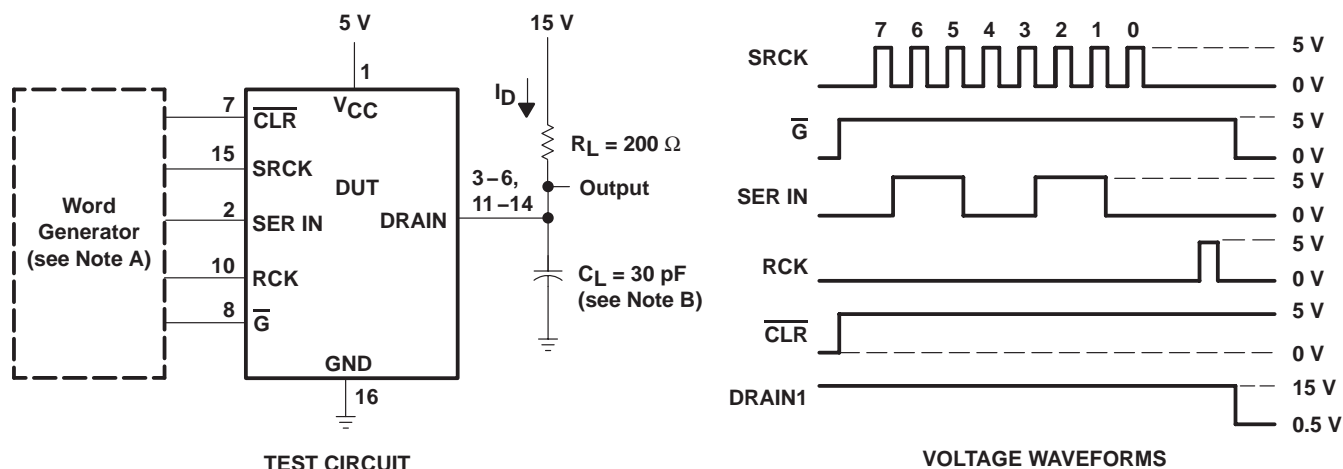

- NOTES: A. The word generator has the following characteristics: $t_r \leq 10\text{ ns}$, $t_f \leq 10\text{ ns}$, $t_w = 300\text{ ns}$, pulsed repetition rate (PRR) = 5 kHz, $Z_O = 50\ \Omega$.
 B. C_L includes probe and jig capacitance.

Figure 1. Resistive-Load Test Circuit and Voltage Waveforms

TPIC6C596 POWER LOGIC 8-BIT SHIFT REGISTER

SLIS093B – MARCH 2000 – REVISED MAY 2004

PARAMETER MEASUREMENT INFORMATION

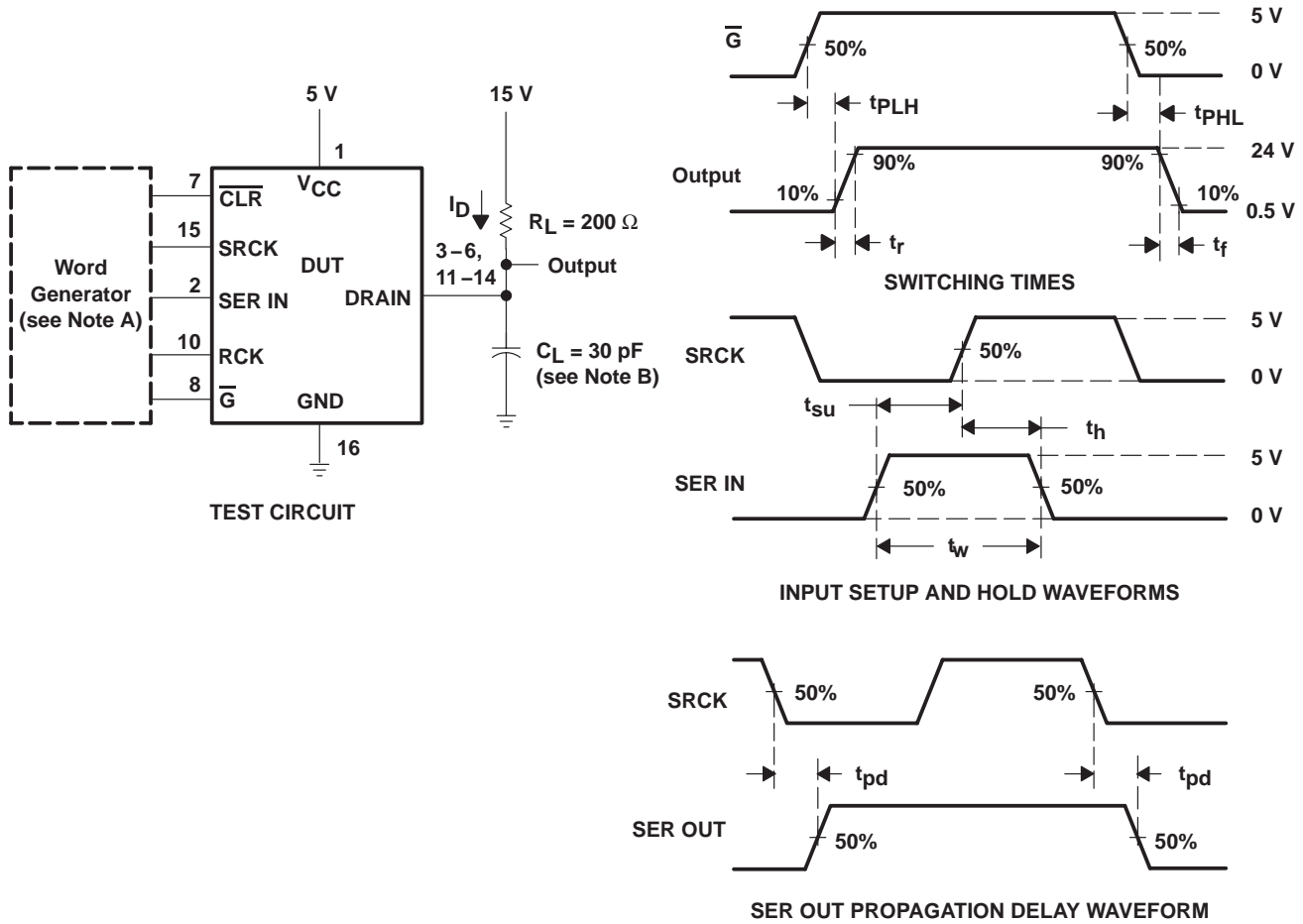

- NOTES: A. The word generator has the following characteristics: $t_r \leq 10 \text{ ns}$, $t_f \leq 10 \text{ ns}$, $t_w = 300 \text{ ns}$, pulsed repetition rate (PRR) = 5 kHz, $Z_O = 50 \Omega$.
 B. C_L includes probe and jig capacitance.

Figure 2. Test Circuit, Switching Times, and Voltage Waveforms

PARAMETER MEASUREMENT INFORMATION

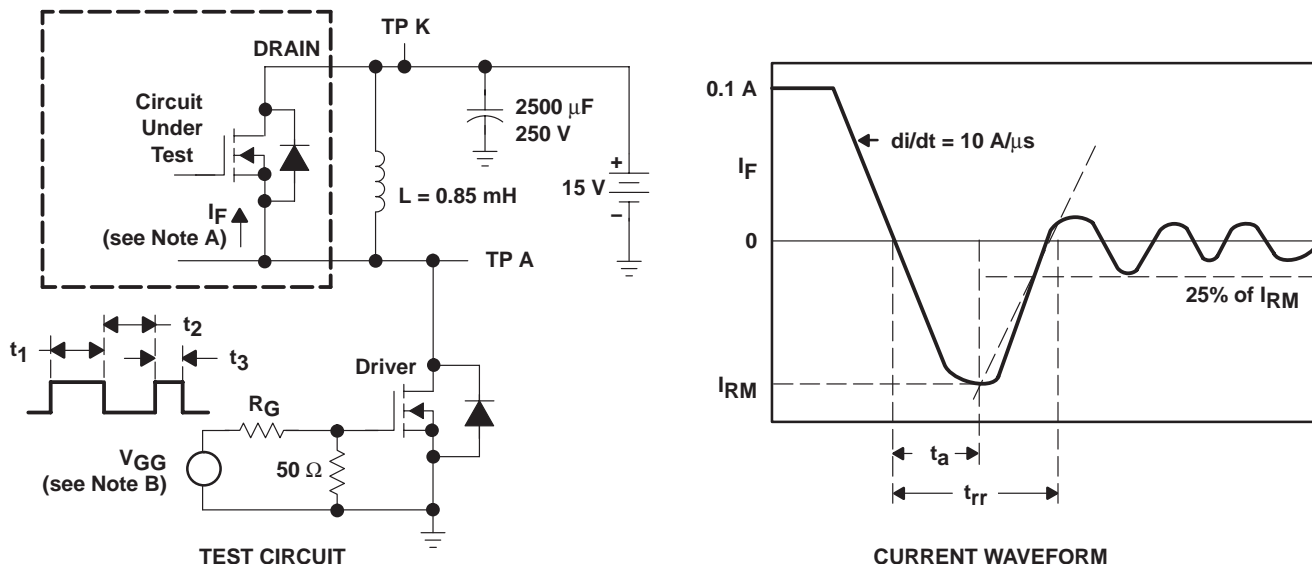

- NOTES: A. The DRAIN terminal under test is connected to the TP K test point. All other terminals are connected together and connected to the TP A test point.
 B. The V_{GG} amplitude and R_G are adjusted for $di/dt = 10 \text{ A}/\mu\text{s}$. A V_{GG} double-pulse train is used to set $I_F = 0.1 \text{ A}$, where $t_1 = 10 \mu\text{s}$, $t_2 = 7 \mu\text{s}$, and $t_3 = 3 \mu\text{s}$.

Figure 3. Reverse-Recovery-Current Test Circuit and Waveforms of Source-to-Drain Diode

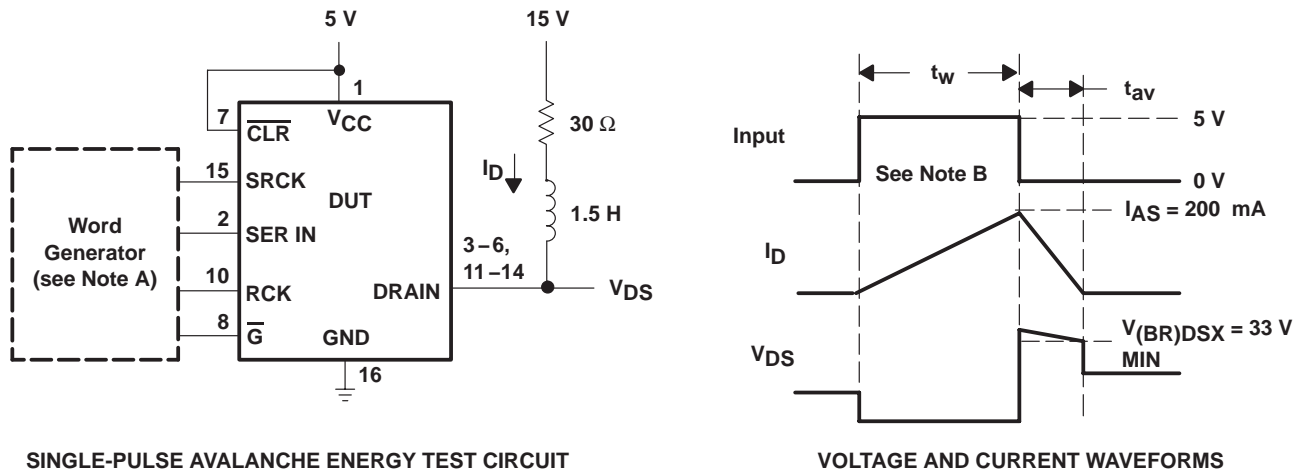

- NOTES: A. The word generator has the following characteristics: $t_r \leq 10 \text{ ns}$, $t_f \leq 10 \text{ ns}$, $Z_O = 50 \Omega$.
 B. Input pulse duration, t_w , is increased until peak current $I_{AS} = 200 \text{ mA}$.
 Energy test level is defined as $E_{AS} = I_{AS} \times V_{(BR)DSX} \times t_{av}/2 = 30 \text{ mJ}$.

Figure 4. Single-Pulse Avalanche Energy Test Circuit and Waveforms

TPIC6C596 POWER LOGIC 8-BIT SHIFT REGISTER

SLIS093B – MARCH 2000 – REVISED MAY 2004

TYPICAL CHARACTERISTICS

PEAK AVALANCHE CURRENT
vs
TIME DURATION OF AVALANCHE

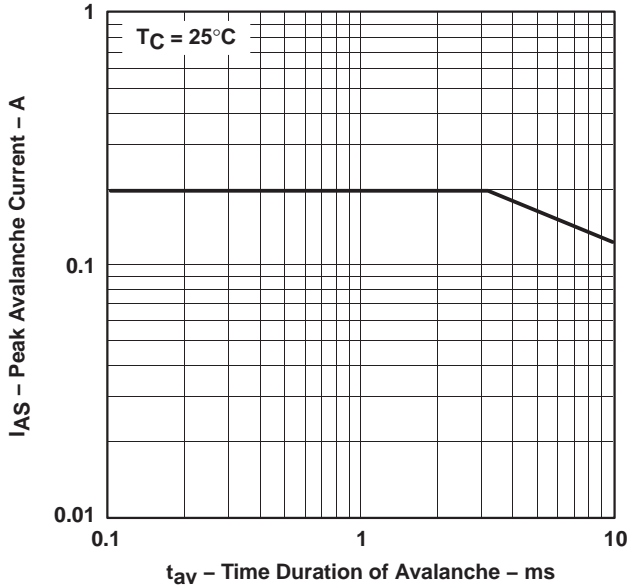

Figure 5

SUPPLY CURRENT
vs
FREQUENCY

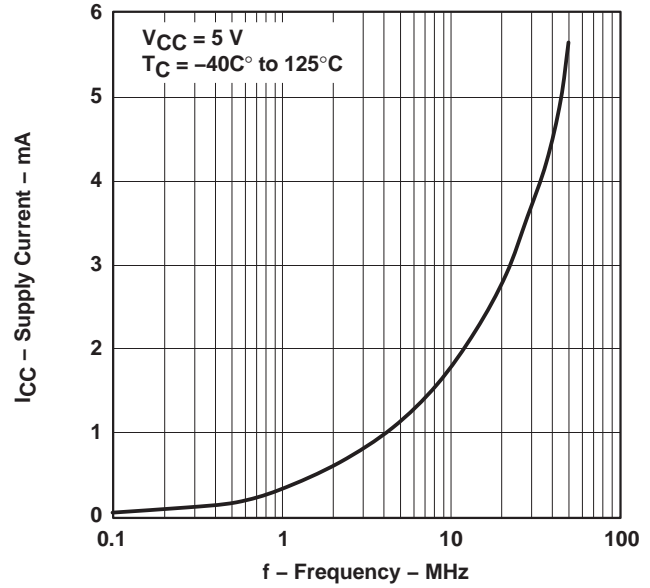

Figure 6

DRAIN-TO-SOURCE ON-STATE RESISTANCE
vs
DRAIN CURRENT

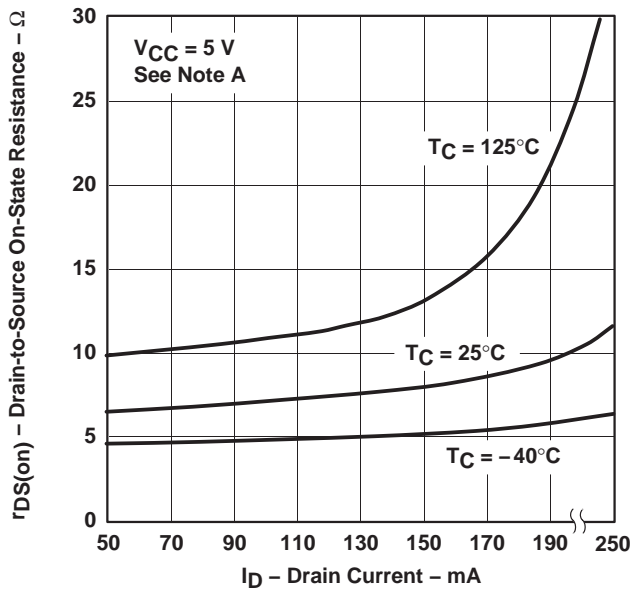

Figure 7

STATIC
DRAIN-TO-SOURCE ON-STATE RESISTANCE
vs
LOGIC SUPPLY VOLTAGE

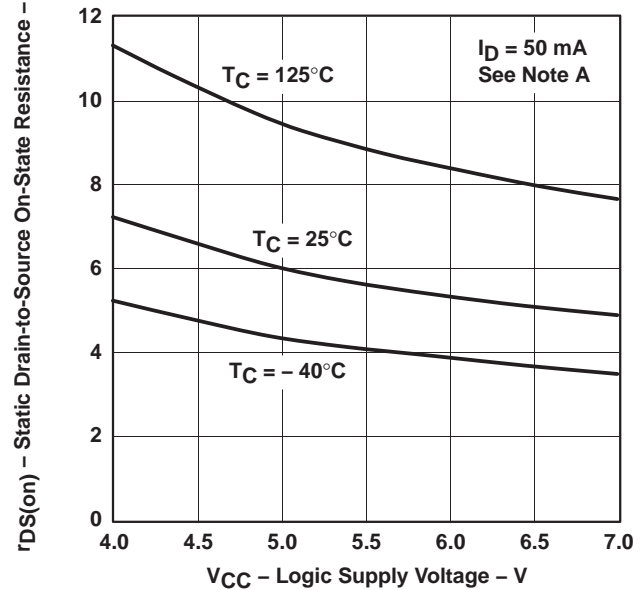

Figure 8

NOTE A: Technique should limit $T_J - T_C$ to 10°C maximum.

TYPICAL CHARACTERISTICS

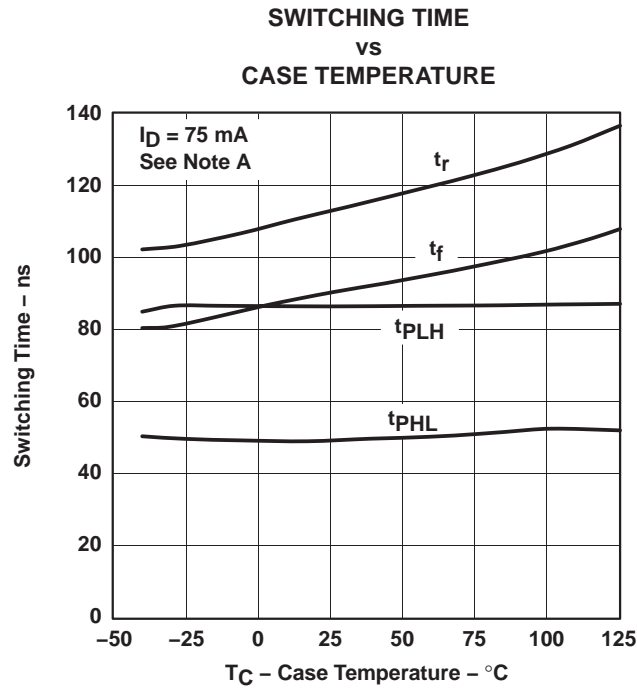

Figure 9

NOTE A: Technique should limit T_J – T_C to 10°C maximum.

TPIC6C596 POWER LOGIC 8-BIT SHIFT REGISTER

SLIS093B – MARCH 2000 – REVISED MAY 2004

THERMAL INFORMATION

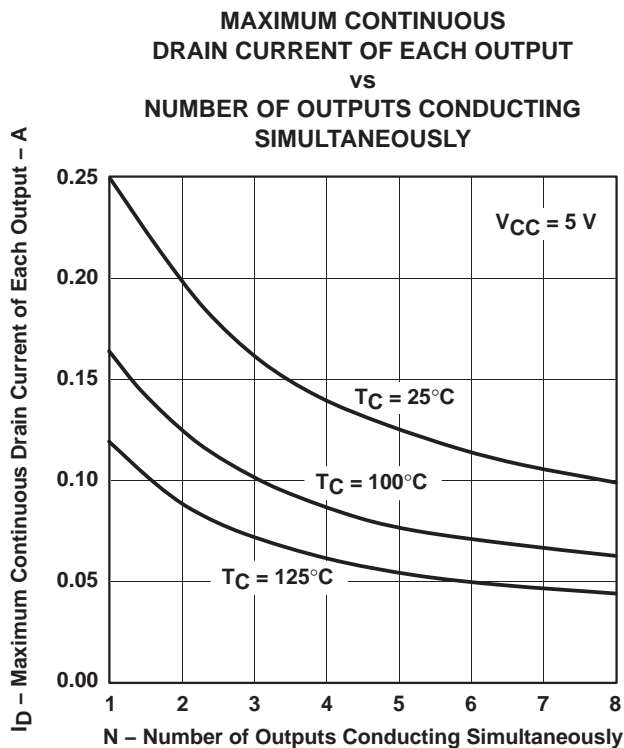

Figure 10

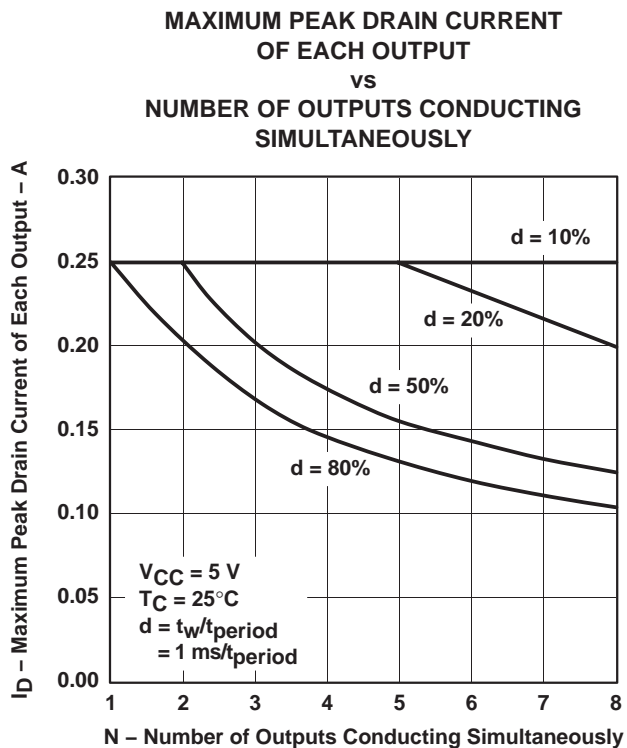
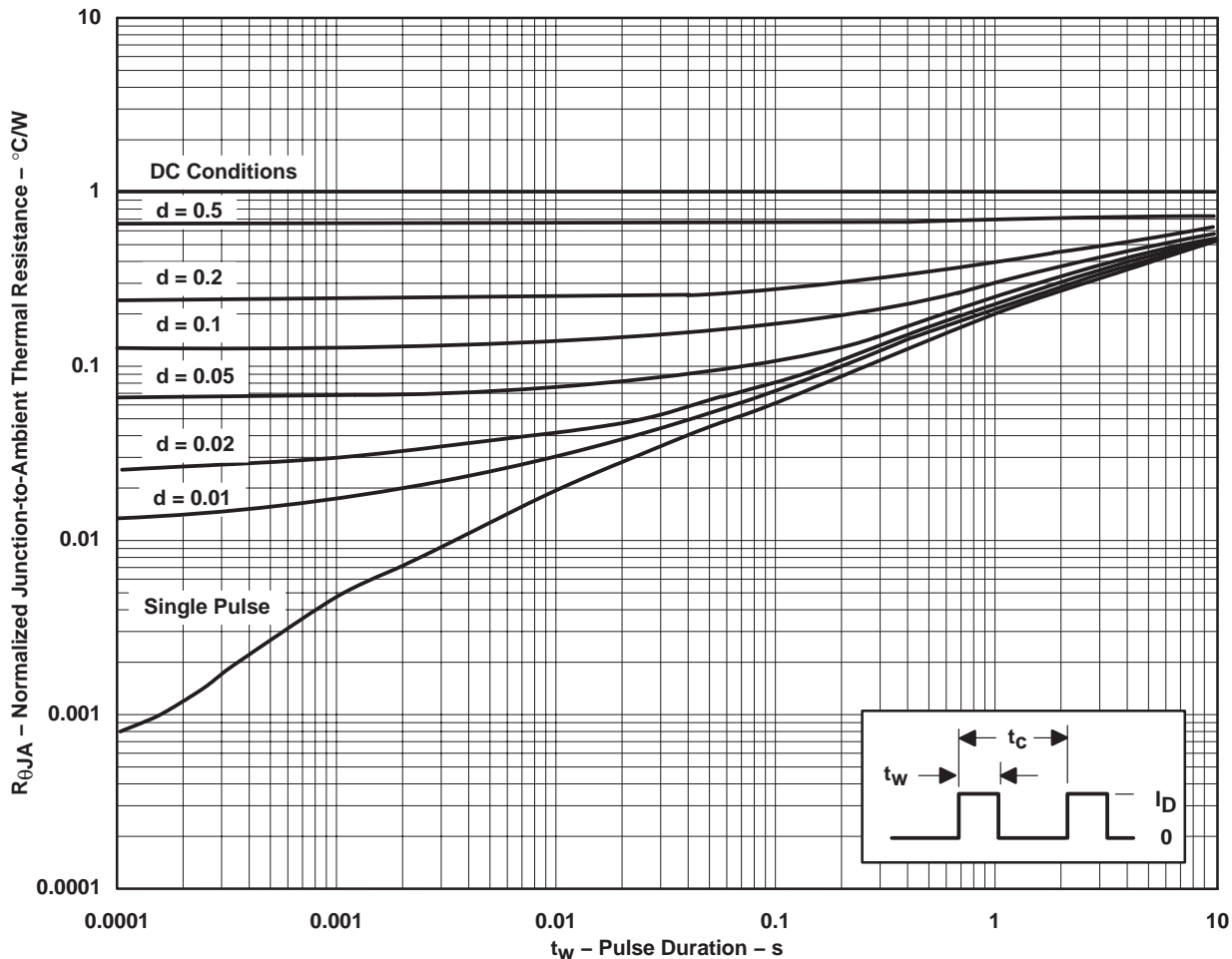

Figure 11

THERMAL INFORMATION

D PACKAGE†
NORMALIZED JUNCTION-TO-AMBIENT THERMAL RESISTANCE
VS
PULSE DURATION



† Device mounted on FR4 printed-circuit board with no heat sink

NOTES: $Z_{\theta A}(t) = r(t) R_{\theta JA}$
 t_w = pulse duration
 t_c = cycle time
 d = duty cycle = t_w/t_c

Figure 12

IMPORTANT NOTICE

Texas Instruments Incorporated and its subsidiaries (TI) reserve the right to make corrections, modifications, enhancements, improvements, and other changes to its products and services at any time and to discontinue any product or service without notice. Customers should obtain the latest relevant information before placing orders and should verify that such information is current and complete. All products are sold subject to TI's terms and conditions of sale supplied at the time of order acknowledgment.

TI warrants performance of its hardware products to the specifications applicable at the time of sale in accordance with TI's standard warranty. Testing and other quality control techniques are used to the extent TI deems necessary to support this warranty. Except where mandated by government requirements, testing of all parameters of each product is not necessarily performed.

TI assumes no liability for applications assistance or customer product design. Customers are responsible for their products and applications using TI components. To minimize the risks associated with customer products and applications, customers should provide adequate design and operating safeguards.

TI does not warrant or represent that any license, either express or implied, is granted under any TI patent right, copyright, mask work right, or other TI intellectual property right relating to any combination, machine, or process in which TI products or services are used. Information published by TI regarding third-party products or services does not constitute a license from TI to use such products or services or a warranty or endorsement thereof. Use of such information may require a license from a third party under the patents or other intellectual property of the third party, or a license from TI under the patents or other intellectual property of TI.

Reproduction of information in TI data books or data sheets is permissible only if reproduction is without alteration and is accompanied by all associated warranties, conditions, limitations, and notices. Reproduction of this information with alteration is an unfair and deceptive business practice. TI is not responsible or liable for such altered documentation.

Resale of TI products or services with statements different from or beyond the parameters stated by TI for that product or service voids all express and any implied warranties for the associated TI product or service and is an unfair and deceptive business practice. TI is not responsible or liable for any such statements.

Following are URLs where you can obtain information on other Texas Instruments products and application solutions:

Products		Applications	
Amplifiers	amplifier.ti.com	Audio	www.ti.com/audio
Data Converters	dataconverter.ti.com	Automotive	www.ti.com/automotive
DSP	dsp.ti.com	Broadband	www.ti.com/broadband
Interface	interface.ti.com	Digital Control	www.ti.com/digitalcontrol
Logic	logic.ti.com	Military	www.ti.com/military
Power Mgmt	power.ti.com	Optical Networking	www.ti.com/opticalnetwork
Microcontrollers	microcontroller.ti.com	Security	www.ti.com/security
		Telephony	www.ti.com/telephony
		Video & Imaging	www.ti.com/video
		Wireless	www.ti.com/wireless

Mailing Address: Texas Instruments
Post Office Box 655303 Dallas, Texas 75265