

**features**

- Qualification in Accordance With AEC-Q100†
- Qualified for Automotive Applications
- Customer-Specific Configuration Control Can Be Supported Along With Major-Change Approval†
- ESD Protection Exceeds 2000 V Per MIL-STD-883, Method 3015; Using Human Body Model (C = 100 pF, R = 1500 Ω)
- Power-On Reset Generator With Fixed Delay Time of 200 ms (TPS3823/4/5/8) or 25 ms (TPS3820)
- Manual Reset Input (TPS3820/3/5/8)
- Reset Output Available in Active-Low (TPS3820/3/4/5), Active-High (TPS3824) and Open-Drain (TPS3828)
- Supply Voltage Supervision Range 2.5 V, 3 V, 3.3 V, 5 V
- Watchdog Timer (TPS3820/3/4/8)
- Supply Current of 15 μA (Typ)
- SOT23-5 Package

**applications**

- Applications Using Automotive DSPs, Microcontrollers, or Microprocessors
- Industrial Equipment
- Programmable Controls
- Automotive Systems
- Battery-Powered Equipment
- Intelligent Instruments
- Wireless Communications Systems

† Contact factory for details. Q100 qualification data available on request.

**description**

The TPS382x family of supervisors provides circuit initialization and timing supervision, primarily for DSP and processor-based systems.

TPS3820, TPS3823, TPS3828 . . . DBV PACKAGE

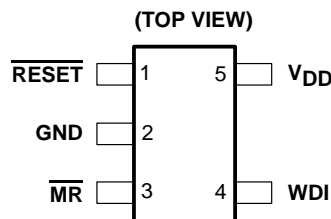

TPS3824 . . . DBV PACKAGE

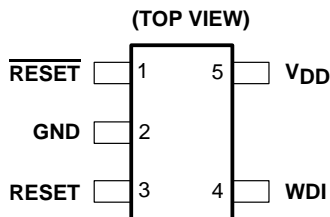

TPS3825 . . . DBV PACKAGE

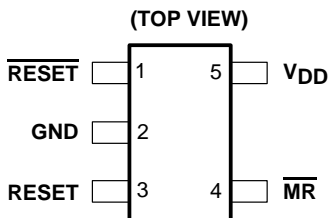

**typical application**

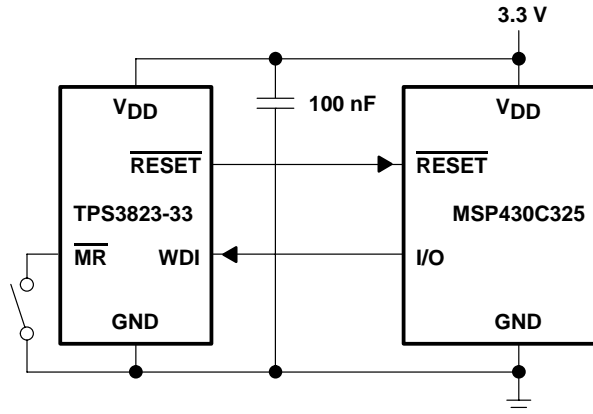

Please be aware that an important notice concerning availability, standard warranty, and use in critical applications of Texas Instruments semiconductor products and disclaimers thereto appears at the end of this data sheet.

PRODUCTION DATA information is current as of publication date. Products conform to specifications per the terms of Texas Instruments standard warranty. Production processing does not necessarily include testing of all parameters.

# TPS3820-xx-Q1, TPS3823-xx-Q1, TPS3824-xx-Q1, TPS3825-xx-Q1, TPS3828-xx-Q1 PROCESSOR SUPERVISORY CIRCUITS

SGLS143A – DECEMBER 2002 – REVISED JANUARY 2003

## description (continued)

During power-on,  $\overline{\text{RESET}}$  is asserted when supply voltage  $V_{DD}$  becomes higher than 1.1 V. Thereafter, the supply voltage supervisor monitors  $V_{DD}$  and keeps  $\overline{\text{RESET}}$  active as long as  $V_{DD}$  remains below the threshold voltage  $V_{IT-}$ . An internal timer delays the return of the output to the inactive state (high) to ensure proper system reset. The delay time,  $t_d$ , starts after  $V_{DD}$  has risen above the threshold voltage  $V_{IT-}$ . When the supply voltage drops below the threshold voltage  $V_{IT-}$ , the output becomes active (low) again. No external components are required. All the devices of this family have a fixed-sense threshold voltage  $V_{IT-}$  set by an internal voltage divider.

The TPS3820/3/5/8 devices incorporate a manual reset input,  $\overline{\text{MR}}$ . A low level at  $\overline{\text{MR}}$  causes  $\overline{\text{RESET}}$  to become active. The TPS3824/5 devices include a high-level output RESET. TPS3820/3/4/8 have a watchdog timer that is periodically triggered by a positive or negative transition at WDI. When the supervising system fails to retrigger the watchdog circuit within the time-out interval,  $t_{\text{tout}}$ ,  $\overline{\text{RESET}}$  becomes active for the time period  $t_d$ . This event also reinitializes the watchdog timer. Leaving WDI unconnected disables the watchdog.

In applications where the input to the WDI pin may be active (transitioning high and low) when the TPS3820/3/4/8 is asserting  $\overline{\text{RESET}}$ , the TPS3820/3/4/8 does not return to a non-reset state when the input voltage is above  $V_t$ . If the application requires that input to WDI is active when  $\overline{\text{RESET}}$  is asserted, WDI must be decoupled from the active signal. This can be accomplished by using an N-channel FET in series with the WDI pin, with the gate of the FET connected to the  $\overline{\text{RESET}}$  output as shown in Figure 1.

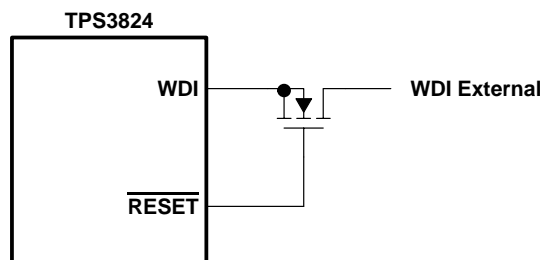

Figure 1

The product spectrum is designed for supply voltages of 2.5 V, 3 V, 3.3 V, and 5 V. The circuits are available in a 5-pin SOT23-5 package. The TPS382x-xxQ-Q1 devices are characterized for operation over a temperature range of  $-40^{\circ}\text{C}$  to  $125^{\circ}\text{C}$ , and are qualified in accordance with AEC-Q100 stress test qualification for integrated circuits.

# TPS3820-xx-Q1, TPS3823-xx-Q1, TPS3824-xx-Q1, TPS3825-xx-Q1, TPS3828-xx-Q1 PROCESSOR SUPERVISORY CIRCUITS

SGLS143A – DECEMBER 2002 – REVISED JANUARY 2003

## PACKAGE INFORMATION

DEVICE NAME	THRESHOLD VOLTAGE	MARKING
TPS3820-33QDBVRQ1†	2.93 V	PDEQ
TPS3820-50QDBVRQ1†	4.55 V	PDDQ
TPS3823-25QDBVRQ1†	2.25 V	PAPQ
TPS3823-30QDBVRQ1†	2.63 V	PAQQ
TPS3823-33QDBVRQ1†	2.93 V	PARQ
TPS3823-50QDBVRQ1†	4.55 V	PASQ
TPS3824-25QDBVRQ1†	2.25 V	PATQ
TPS3824-30QDBVRQ1†	2.63 V	PAUQ
TPS3824-33QDBVRQ1†	2.93 V	PAVQ
TPS3824-50QDBVRQ1†	4.55 V	PAWQ
TPS3825-33QDBVRQ1†	2.93 V	PDGQ
TPS3825-50QDBVRQ1†	4.55 V	PDFQ
TPS3828-33QDBVRQ1†	2.93 V	PDIQ
TPS3828-50QDBVRQ1†	4.55 V	PDHQ

† The DBVR package indicates tape and reel of 3000 parts.

## FUNCTION/TRUTH TABLE

INPUTS		OUTPUTS	
$\overline{MR}^\ddagger$	$V_{DD} > V_{IT}$	$\overline{RESET}$	$RESET^\S$
L	0	L	H
L	1	L	H
H	0	L	H
H	1	H	L

‡ TPS3820/3/5/8

§ TPS3824/5

# TPS3820-xx-Q1, TPS3823-xx-Q1, TPS3824-xx-Q1, TPS3825-xx-Q1, TPS3828-xx-Q1 PROCESSOR SUPERVISORY CIRCUITS

SGLS143A – DECEMBER 2002 – REVISED JANUARY 2003

## functional block diagram

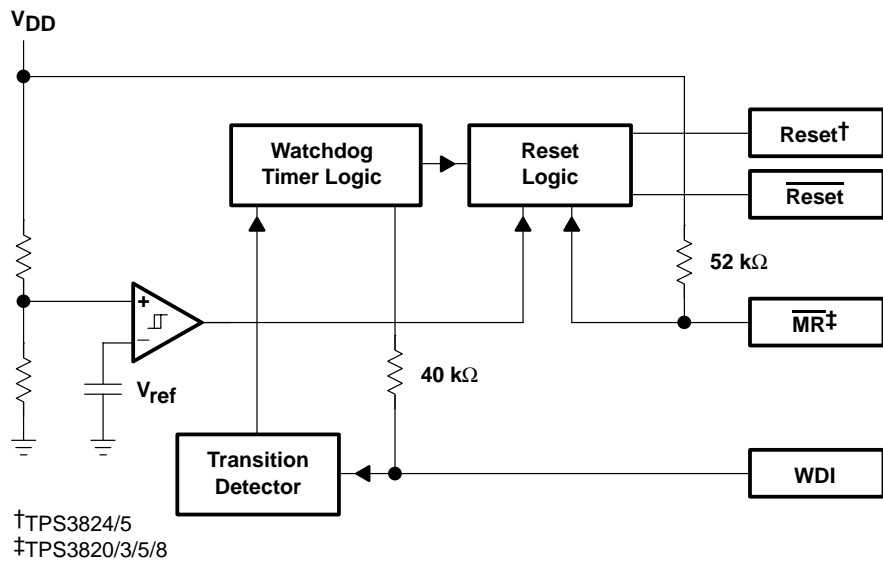

## timing diagram

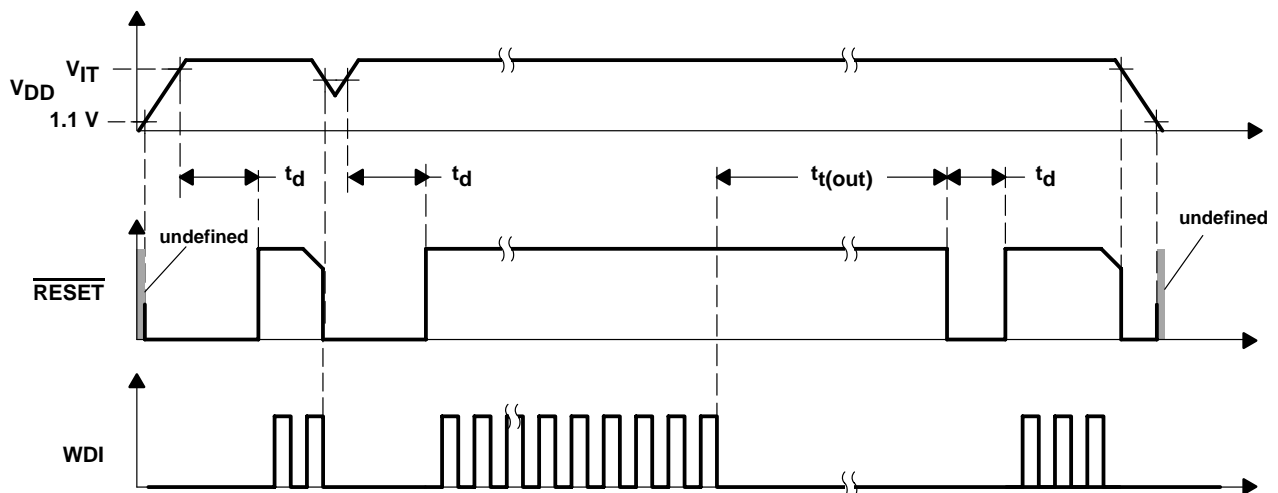

# TPS3820-xx-Q1, TPS3823-xx-Q1, TPS3824-xx-Q1, TPS3825-xx-Q1, TPS3828-xx-Q1 PROCESSOR SUPERVISORY CIRCUITS

SGLS143A – DECEMBER 2002 – REVISED JANUARY 2003

## absolute maximum ratings over operating free-air temperature range (unless otherwise noted)†

Supply voltage, $V_{DD}$ (see Note 1)	6 V
RESET, $\overline{\text{RESET}}$ , MR, WDI (see Note 1)	-0.3 V to ( $V_{DD} + 0.3$ V)
Maximum low output current, $I_{OL}$	5 mA
Maximum high output current, $I_{OH}$	-5 mA
Input clamp current range, $I_{IK}$ ( $V_I < 0$ or $V_I > V_{DD}$ )	$\pm 10$ mA
Output clamp current range, $I_{OK}$ ( $V_O < 0$ or $V_O > V_{DD}$ )	$\pm 10$ mA
Continuous total power dissipation	See Dissipation Rating Table
Operating free-air temperature range, $T_A$	-40°C to 125°C
Storage temperature range, $T_{stg}$	-65°C to 150°C
Soldering temperature	260°C

† Stresses beyond those listed under “absolute maximum ratings” may cause permanent damage to the device. These are stress ratings only, and functional operation of the device at these or any other conditions beyond those indicated under “recommended operating conditions” is not implied. Exposure to absolute-maximum-rated conditions for extended periods may affect device reliability.

NOTE 1: All voltage values are with respect to GND.

**DISSIPATION RATING TABLE**

PACKAGE	$T_A \leq 25^\circ\text{C}$ POWER RATING	OPERATING FACTOR ABOVE $T_A = 25^\circ\text{C}$	$T_A = 70^\circ\text{C}$ POWER RATING	$T_A = 85^\circ\text{C}$ POWER RATING	$T_A = 125^\circ\text{C}$ POWER RATING
DBV	437 mW	3.5 mW/°C	280 mW	227 mW	87 mW

## recommended operating conditions

	MIN	MAX	UNIT
Supply voltage, $V_{DD}$	1.1	5.5	V
Input voltage, $V_I$	0	$V_{DD} + 0.3$	V
High-level input voltage at $\overline{\text{MR}}$ and WDI, $V_{IH}$	$0.7 \times V_{DD}$		V
Low-level input voltage, $V_{IL}$		$0.3 \times V_{DD}$	V
Input transition rise and fall rate at $\overline{\text{MR}}$ or WDI, $\Delta t/\Delta V$		100	ns/V
Operating free-air temperature range, $T_A$	-40	125	°C



# TPS3820-xx-Q1, TPS3823-xx-Q1, TPS3824-xx-Q1, TPS3825-xx-Q1, TPS3828-xx-Q1 PROCESSOR SUPERVISORY CIRCUITS

SGLS143A – DECEMBER 2002 – REVISED JANUARY 2003

electrical characteristics over recommended operating free-air temperature range (unless otherwise noted)

PARAMETER		TEST CONDITIONS	MIN	TYP	MAX	UNIT		
V <sub>OH</sub>	High-level output voltage	RESET	TPS382x-25	0.8 × V <sub>DD</sub>		V		
			TPS382x-30					
			TPS382x-33					
	TPS382x-50	V <sub>DD</sub> = V <sub>IT-</sub> + 0.2 V I <sub>OH</sub> = -120 μA	V <sub>DD</sub> - 1.5 V					
	RESET	TPS3824-25	V <sub>DD</sub> ≥ 1.8 V, I <sub>OH</sub> = -100 μA	0.8 × V <sub>DD</sub>		V		
		TPS3825-25						
		TPS3824-30						
		TPS3825-30						
TPS3824-33	V <sub>DD</sub> ≥ 1.8 V, I <sub>OH</sub> = -150 μA							
TPS3825-33								
TPS3824-50								
TPS3825-50								
V <sub>OL</sub>	Low-level output voltage	RESET	TPS3824-25		0.4	V		
			TPS3825-25					
			TPS3824-30					
			TPS3825-30					
	TPS3824-33	V <sub>DD</sub> = V <sub>IT-</sub> + 0.2 V I <sub>OL</sub> = 1.2 mA						
	TPS3825-33							
	TPS3824-50	V <sub>DD</sub> = V <sub>IT-</sub> + 0.2 V I <sub>OL</sub> = 3 mA						
	TPS3825-50							
RESET	TPS382x-25	V <sub>DD</sub> = V <sub>IT-</sub> - 0.2 V I <sub>OL</sub> = 1 mA		0.45	V			
	TPS382x-30							
	TPS382x-33							
	TPS382x-50							
Power-up reset voltage (see Note 2)			V <sub>DD</sub> ≥ 1.1 V, I <sub>OL</sub> = 20 μA		0.4	V		
V <sub>IT-</sub>	Negative-going input threshold voltage (see Note 3)		T <sub>A</sub> = 0°C to 85°C	TPS382x-25	2.21	2.25	2.30	V
				TPS382x-30	2.59	2.63	2.69	
				TPS382x-33	2.88	2.93	3	
				TPS382x-50	4.49	4.55	4.64	
	RESET		T <sub>A</sub> = -40°C to 125°C	TPS382x-25	2.19	2.25	2.30	V
				TPS382x-30	2.55	2.63	2.69	
				TPS382x-33	2.84	2.93	3	
				TPS382x-50	4.44	4.55	4.65	
V <sub>hys</sub>	Hysteresis at V <sub>DD</sub> input			TPS382x-25	30		mV	
				TPS382x-30				
				TPS382x-33				
				TPS382x-50				50

NOTES: 2. The lowest supply voltage at which RESET becomes active. t<sub>r</sub>, V<sub>DD</sub> ≥ 15 μs/V  
3. To ensure best stability of the threshold voltage, a bypass capacitor (ceramic, 0.1 μF) should be placed near the supply terminals.



# TPS3820-xx-Q1, TPS3823-xx-Q1, TPS3824-xx-Q1, TPS3825-xx-Q1, TPS3828-xx-Q1 PROCESSOR SUPERVISORY CIRCUITS

SGLS143A – DECEMBER 2002 – REVISED JANUARY 2003

**electrical characteristics over recommended operating free-air temperature range (unless otherwise noted) (continued)**

PARAMETER		TEST CONDITIONS	MIN	TYP	MAX	UNIT
$I_{IH(AV)}$	Average high-level input current	WDI WDI = $V_{DD}$ , time average (dc = 88%)	120			$\mu A$
	Average low-level input current		WDI = 0.3 V, $V_{DD} = 5.5$ V time average (dc = 12%)	-15		
$I_{IH}$	High-level input current	WDI	WDI = $V_{DD}$ 140 190			
		$\overline{MR}$	$\overline{MR} = V_{DD} \times 0.7$ , $V_{DD} = 5.5$ V -40 -60			
$I_{IL}$	Low-level input current	WDI	WDI = 0.3 V, $V_{DD} = 5.5$ V 140 190			
		$\overline{MR}$	$\overline{MR} = 0.3$ V, $V_{DD} = 5.5$ V -110 -160			
$I_{OS}$	Output short-circuit current (see Note 4)	TPS382x-25	$V_{DD} = V_{IT, max} + 0.2$ V, $V_O = 0$ V			$\mu A$
		TPS382x-30				
		TPS382x-33				
		TPS382x-50				
$I_{DD}$	Supply current	WDI and $\overline{MR}$ unconnected, Outputs unconnected	15 25			$\mu A$
	Internal pullup resistor at $\overline{MR}$		52			k $\Omega$
$C_i$	Input capacitance at $\overline{MR}$ , WDI	$V_I = 0$ V to 5.5 V	5			pF

NOTE 4: The  $\overline{RESET}$  short-circuit current is the maximum pullup current when  $\overline{RESET}$  is driven low by a  $\mu P$  bidirectional reset pin.

**timing requirements at  $R_L = 1$  M $\Omega$ ,  $C_L = 50$  pF,  $T_A = 25^\circ C$**

PARAMETER		TEST CONDITIONS	MIN	MAX	UNIT	
$t_w$	Pulse width	at $V_{DD}$	$V_{DD} = V_{IT-} + 0.2$ V, $V_{DD} = V_{IT-} - 0.2$ V		6	$\mu s$
		at $\overline{MR}$	$V_{DD} \geq V_{IT-} + 0.2$ V, $V_{IL} = 0.3 \times V_{DD}$ , $V_{IH} = 0.7 \times V_{DD}$		1	$\mu s$
		at WDI	$V_{DD} \geq V_{IT-} + 0.2$ V, $V_{IL} = 0.3 \times V_{DD}$ , $V_{IH} = 0.7 \times V_{DD}$		100	ns

**switching characteristics at  $R_L = 1$  M $\Omega$ ,  $C_L = 50$  pF,  $T_A = 25^\circ C$**

PARAMETER		TEST CONDITIONS	MIN	TYP	MAX	UNIT	
$t_{tout}$	Watchdog time out	TPS3820	$V_{DD} \geq V_{IT-} + 0.2$ V, See Timing Diagram			112 200 310	ms
		TPS3823/4/8				0.9 1.6 2.5	s
$t_d$	Delay time	TPS3820	$V_{DD} \geq V_{IT-} + 0.2$ V, See timing diagram			15 25 37	ms
		TPS3823/4/5/8				120 200 300	
$t_{PHL}$	Propagation (delay) time, high-to-low-level output	$\overline{MR}$ to $\overline{RESET}$ delay (TPS3820/3/5/8)	$V_{DD} \geq V_{IT-} + 0.2$ V, $V_{IL} = 0.3 \times V_{DD}$ , $V_{IH} = 0.7 \times V_{DD}$			0.1	$\mu s$
		$V_{DD}$ to $\overline{RESET}$ delay	$V_{IL} = V_{IT-} - 0.2$ V, $V_{IH} = V_{IT-} + 0.2$ V			25	
$t_{PLH}$	Propagation (delay) time, low-to-high-level output	$\overline{MR}$ to $\overline{RESET}$ delay (TPS3824/5)	$V_{DD} \geq V_{IT-} + 0.2$ V, $V_{IL} = 0.3 \times V_{DD}$ , $V_{IH} = 0.7 \times V_{DD}$			0.1	$\mu s$
		$V_{DD}$ to $\overline{RESET}$ delay (TPS3824/5)	$V_{IL} = V_{IT-} - 0.2$ V, $V_{IH} = V_{IT-} + 0.2$ V			25	



TYPICAL CHARACTERISTICS

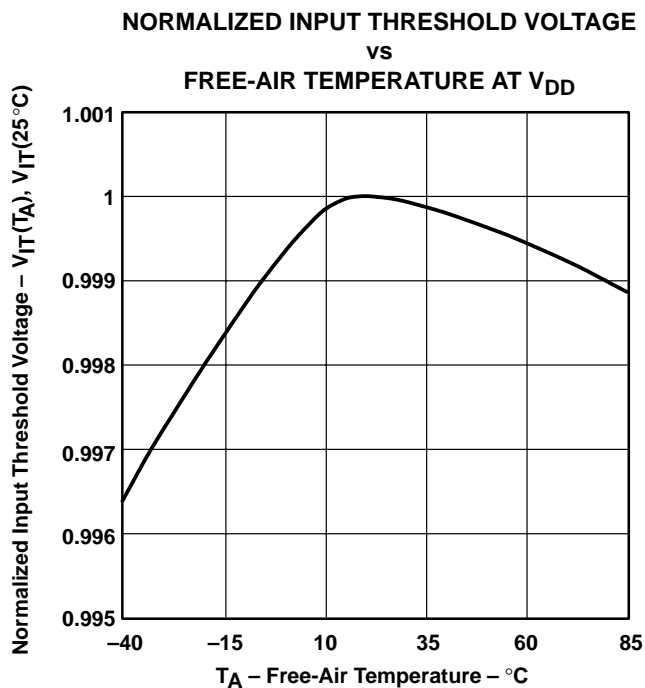

Figure 2

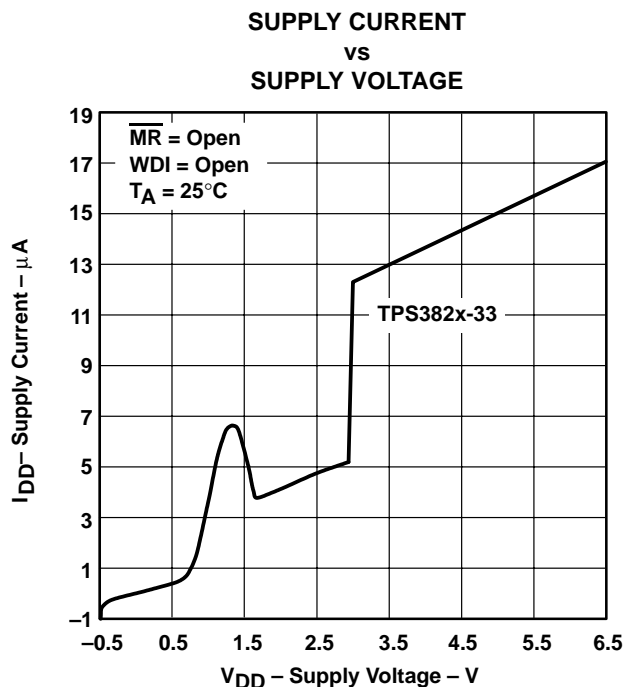

Figure 3

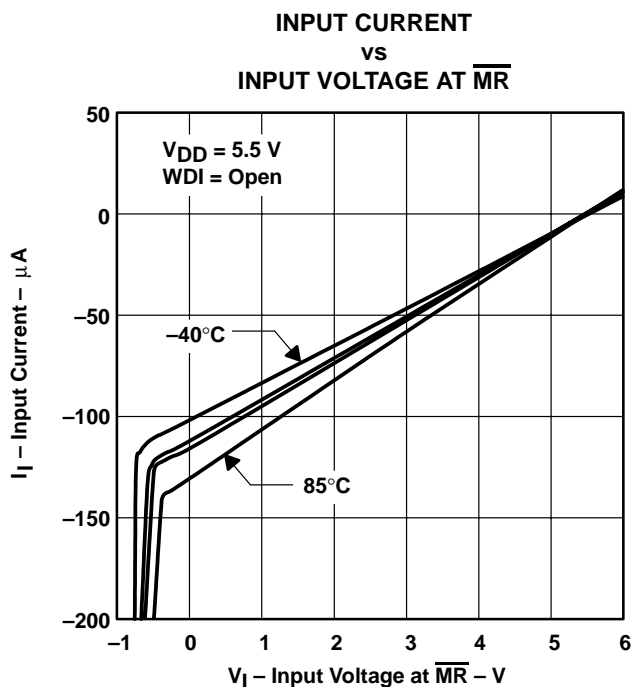

Figure 4

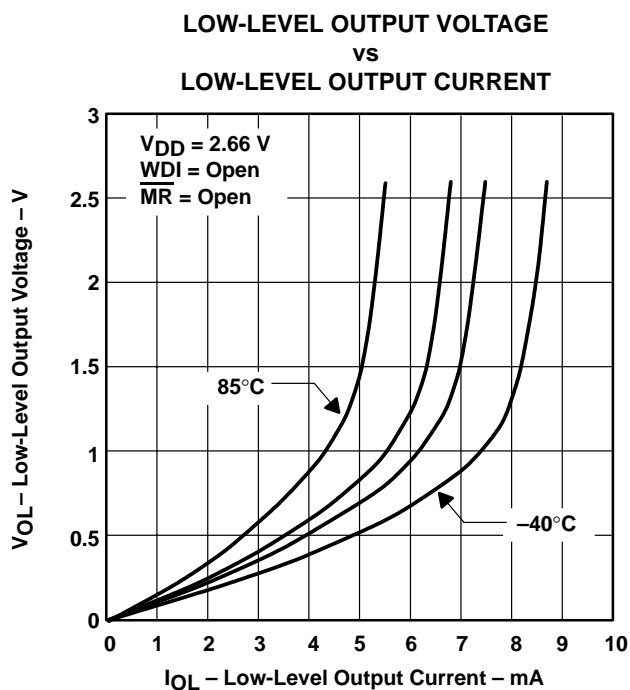

Figure 5

TYPICAL CHARACTERISTICS

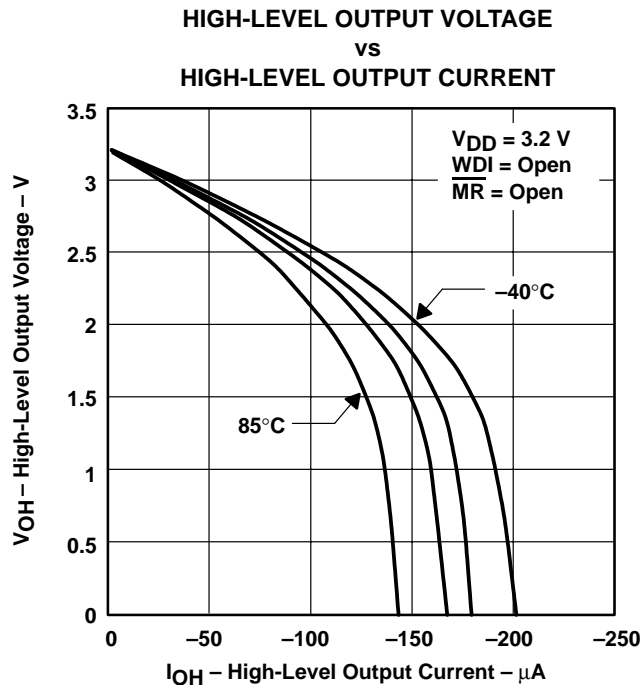

Figure 6

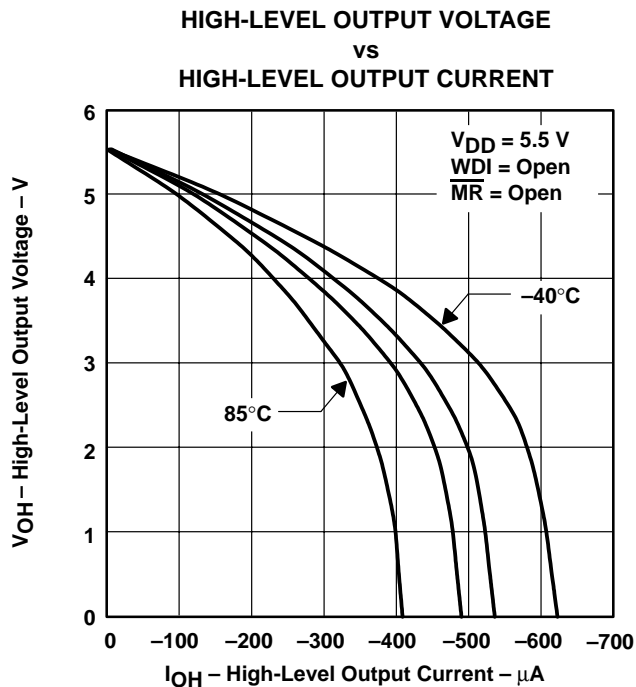

Figure 7

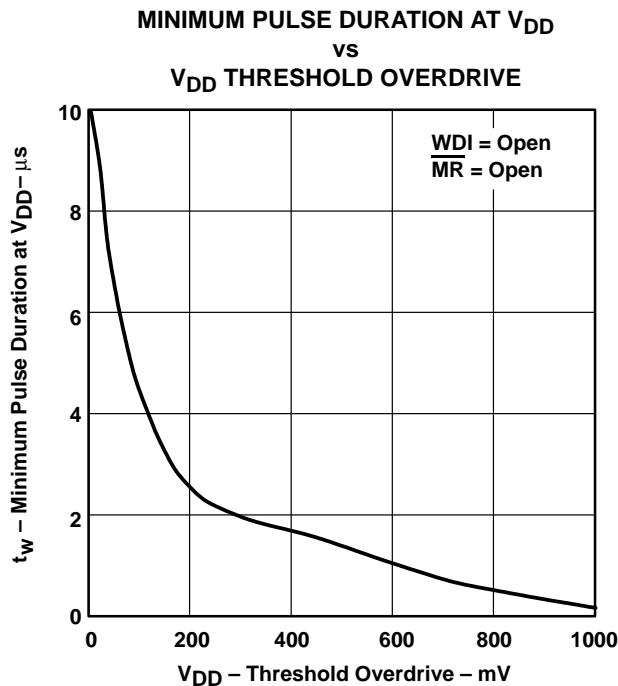

Figure 8

# TPS3820-xx-Q1, TPS3823-xx-Q1, TPS3824-xx-Q1, TPS3825-xx-Q1, TPS3828-xx-Q1 PROCESSOR SUPERVISORY CIRCUITS

SGLS143A – DECEMBER 2002 – REVISED JANUARY 2003

## MECHANICAL DATA

DBV (R-PDSO-G5)

PLASTIC SMALL-OUTLINE

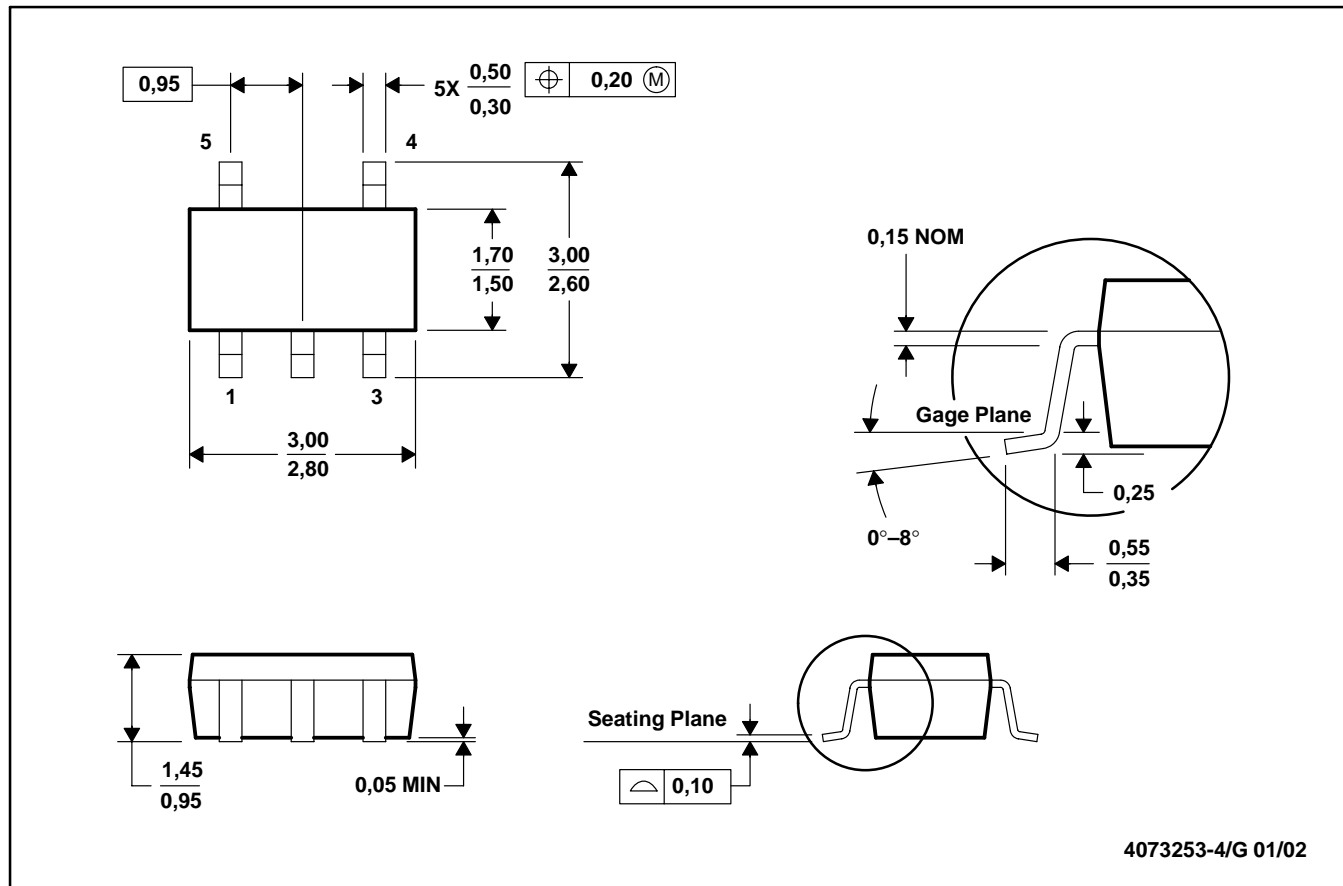

- NOTES:
- A. All linear dimensions are in millimeters.
  - B. This drawing is subject to change without notice.
  - C. Body dimensions do not include mold flash or protrusion.
  - D. Falls within JEDEC MO-178