

HIGH INPUT VOLTAGE, MICROPOWER SC70/SOT-323 PACKAGED 50-mA LDO LINEAR REGULATORS

FEATURES

- 50-mA Low-Dropout Regulator
- Available in 2.5 V, 3.0 V, 3.3 V, 5.0 V, and Adjustable
- 24-V Maximum Input Voltage
- Low 3.2- μ A Quiescent Current at 50 mA
- 5-Pin SC70/SOT-323 (DCK) Package
- Stable With Any Capacitor ($>0.47 \mu\text{F}$)
- Over Current Limitation
- -40°C to 125°C Operating Junction Temperature Range

APPLICATIONS

- Battery Management
- Microcontroller
- PDAs and Notebooks

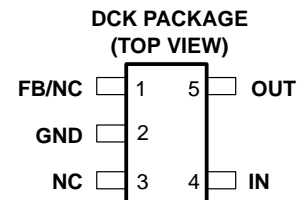

DESCRIPTION

The TPS715xx low-dropout (LDO) voltage regulators offer the benefits of high input voltage, low-dropout voltage, low-power operation, and miniaturized packaging. The devices, which operate over an input range of 2.5 V to 24 V, are stable with any capacitor ($>0.47 \mu\text{F}$). The low dropout voltage and low quiescent current allow operations at extremely low power levels. Therefore, the devices are ideal for powering battery management ICs. Specifically, since the devices are enabled as soon as the applied voltage reaches the minimum input voltage, the output is quickly available to power continuously operating battery charging ICs.

The usual PNP pass transistor has been replaced by a PMOS pass element. Because the PMOS pass element behaves as a low-value resistor, the low dropout voltage, typically 415 mV at 50 mA of load current, is directly proportional to the load current. The low quiescent current (3.2 μA typically) is stable over the entire range of output load current (0 mA to 50 mA).

AVAILABLE OPTIONST

T_J	VOLTAGE	PACKAGE	PART NUMBER	SYMBOL
-40°C to 125°C	2.5 V	SC70/SOT-323 (DCK)	TPS71525DCKR	AQL
			bq71525DCKR	
	3.0 V	SC70/SOT-323 (DCK)	TPS71530DCKR	AQM
			bq71530DCKR	
	3.3 V	SC70/SOT-323 (DCK)	TPS71533DCKR	AQI
			bq71533DCKR	
	5.0 V	SC70/SOT-323 (DCK)	TPS71550DCKR	T48
			bq71550DCKR	
	(Adjustable) 1.2 V–15 V	SC70/SOT-323 (DCK)	TPS71501DCKR	ARB
			bq71501DCKR	

† Contact the factory for other voltage options between 1.25 V and 5.85 V.



Please be aware that an important notice concerning availability, standard warranty, and use in critical applications of Texas Instruments semiconductor products and disclaimers thereto appears at the end of this data sheet.

TPS71525
TPS71530, TPS71533
TPS71501, TPS71550

SLVS338D – MAY 2001 – REVISED DECEMBER 2002

absolute maximum ratings over operating free-air temperature range (unless otherwise noted)[†]

Input voltage range (see Note 1)	–0.3 V to 24 V
Peak output current	Internally limited
ESD rating, HBM	2 kV
ESD rating, CDM	500 V
Continuous total power dissipation	See Dissipation Rating Table
Operating junction temperature range, T _J	–40°C to 125°C
Operating ambient temperature range, T _A	–40°C to 85°C
Storage temperature range, T _{stg}	–65°C to 150°C

[†] Stresses beyond those listed under “absolute maximum ratings” may cause permanent damage to the device. These are stress ratings only, and functional operation of the device at these or any other conditions beyond those indicated under “recommended operating conditions” is not implied. Exposure to absolute-maximum-rated conditions for extended periods may affect device reliability.

NOTE 1: All voltage values are with respect to network ground terminal.

DISSIPATION RATING TABLE

BOARD	PACKAGE	R _{θJC} °C/W	R _{θJA} °C/W	DERATING FACTOR ABOVE T _A = 25°C	T _A ≤ 25°C POWER RATING	T _A = 70°C POWER RATING	T _A = 85°C POWER RATING
Low K [‡]	DCK	165.39	396.24	2.52 mW/°C	252 mW	139 mW	101 mW
High K [§]	DCK	165.39	314.74	3.18 mW/°C	318 mW	175 mW	127 mW

[‡] The JEDEC Low K (1s) board design used to derive this data was a 3 inch x 3 inch, two layer board with 2 ounce copper traces on top of the board.

[§] The JEDEC High K (2s2p) board design used to derive this data was a 3 inch x 3 inch, multilayer board with 1 ounce internal power and ground planes and 2 ounce copper traces on top and bottom of the board.

recommended operating conditions

	MIN	NOM	MAX	UNIT
Input voltage, V _I (see Note 2)	I _O = 10 mA		2.5	V
	I _O = 50 mA		3	
Continuous output current, I _O (see Note 3)	0		50	mA
Operating junction temperature, T _J	–40		125	°C

NOTES: 2. To calculate the minimum input voltage for your maximum output current, use the following formula:

$$V_I(\text{min}) = V_O(\text{max}) + V_{DO}(\text{max load})$$

3. Continuous output current is limited by internal protection circuitry, but it is not recommended that the device operate under conditions beyond those specified in this table for extended periods of time.

**electrical characteristics over recommended operating free-air temperature range,
 $V_I = V_O(\text{typ}) + 1 \text{ V}$, $I_O = 1 \text{ mA}$, $C_O = 1 \mu\text{F}$, (unless otherwise noted)**

PARAMETER		TEST CONDITIONS	MIN	TYP	MAX	UNIT
Output voltage (100 μA to 50 mA Load) (see Note 4)	TPS71501	$T_J = 25^\circ\text{C}$, $1.2 \text{ V} \leq V_O \leq 15 \text{ V}$				V
		$T_J = -40^\circ\text{C}$ to 125°C , $1.2 \text{ V} \leq V_O \leq 15 \text{ V}$	0.96 V_O		1.04 V_O	
	TPS71525	$T_J = 25^\circ\text{C}$, $3.5 \text{ V} < V_I < 24 \text{ V}$		2.5		
		$T_J = -40^\circ\text{C}$ to 125°C , $3.5 \text{ V} < V_I < 24 \text{ V}$	2.4		2.6	
	TPS71530	$T_J = 25^\circ\text{C}$, $4 \text{ V} < V_O < 24 \text{ V}$		3		
		$T_J = -40^\circ\text{C}$ to 125°C , $4 \text{ V} < V_O < 24 \text{ V}$	2.88		3.12	
	TPS71533	$T_J = 25^\circ\text{C}$, $4.3 \text{ V} < V_I < 24 \text{ V}$		3.3		
		$T_J = -40^\circ\text{C}$ to 125°C , $4.3 \text{ V} < V_I < 24 \text{ V}$	3.168		3.432	
	TPS71550	$T_J = 25^\circ\text{C}$, $6 \text{ V} < V_O < 24 \text{ V}$		5		
		$T_J = -40^\circ\text{C}$ to 125°C , $6 \text{ V} < V_O < 24 \text{ V}$	4.8		5.2	
Quiescent current (GND current)		$T_J = 25^\circ\text{C}$, $0 < I_O < 50 \text{ mA}$		3.2		μA
		$T_J = -40^\circ\text{C}$ to 85°C , $I_O = 50 \text{ mA}$			4.2	
		$T_J = -40^\circ\text{C}$ to 125°C , $I_O = 50 \text{ mA}$			4.8	
		$T_J = -40^\circ\text{C}$ to 125°C , $I_O = 50 \text{ mA}$, $V_I = 24 \text{ V}$			5.8	
Load regulation		$T_J = 25^\circ\text{C}$, $I_O = 100 \mu\text{A}$ to 50 mA		22		mV
Output voltage line regulation ($\Delta V_O/V_O$) (see Note 4)		$T_J = 25^\circ\text{C}$, $V_O + 1 \text{ V} < V_I \leq 24 \text{ V}$		20		mV
		$T_J = -40^\circ\text{C}$ to 125°C , $V_O + 1 \text{ V} < V_I \leq 24 \text{ V}$			60	
Output noise voltage		$T_J = 25^\circ\text{C}$, $C_O = 10 \mu\text{F}$, BW = 200 Hz to 100 kHz, $I_O = 50 \text{ mA}$		575		μVrms
Output current limit		$V_O = 0 \text{ V}$, See Note 4	125		750	mA
Power supply ripple rejection		$T_J = 25^\circ\text{C}$, $f = 100 \text{ kHz}$, $C_O = 10 \mu\text{F}$		60		dB
Dropout voltage (see Note 5)		$T_J = 25^\circ\text{C}$, $I_O = 50 \text{ mA}$		415		mV
		$T_J = -40^\circ\text{C}$ to 125°C , $I_O = 50 \text{ mA}$			750	

NOTES: 4. The maximum I_N voltage is 24 V. There is no minimum output current and the maximum output current is 50 mA.
5. I_N voltage equals $V_O(\text{typ}) - 100 \text{ mV}$; The TPS71533 input voltage is set to 3.2 V.

functional block diagram – adjustable version

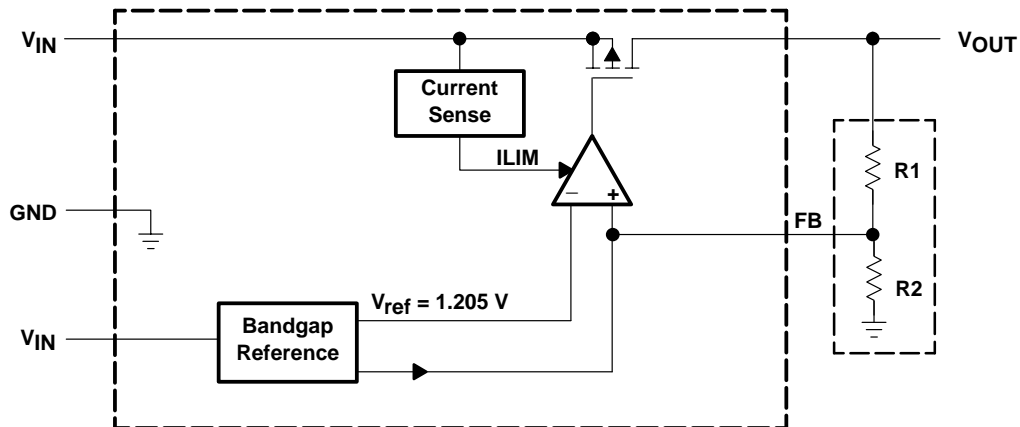

functional block diagram – fixed version

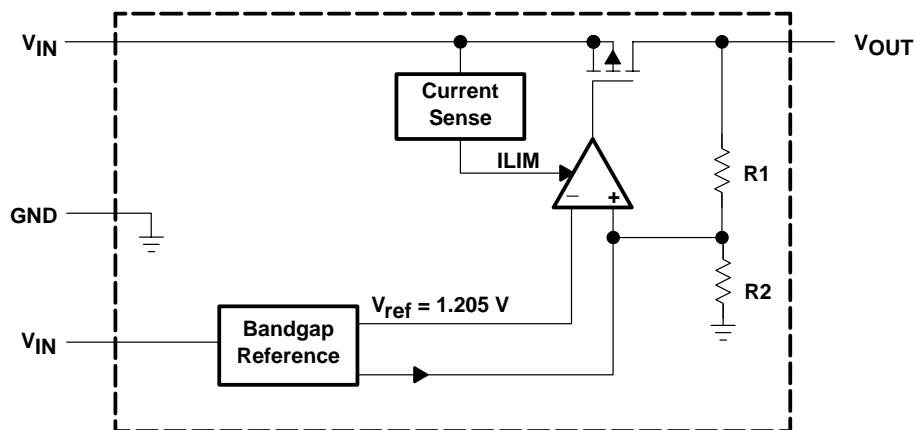

Terminal Functions

TERMINAL NAME	NO.	I/O	DESCRIPTION
FB	1		This terminal is the feedback input voltage for the adjustable device.
GND	2		Ground
IN	4	I	The IN terminal is the power supply input to the device.
NC	1		No connection for fixed option devices
NC	3		No connection
OUT	5	O	The OUT terminal provides the regulated output voltage of the device.

TYPICAL CHARACTERISTICS

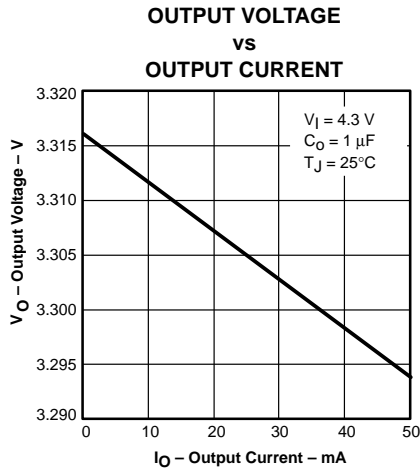

Figure 1

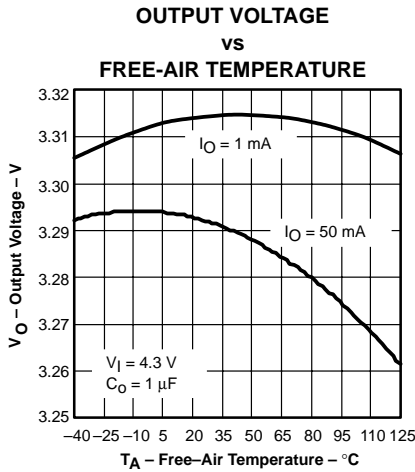

Figure 2

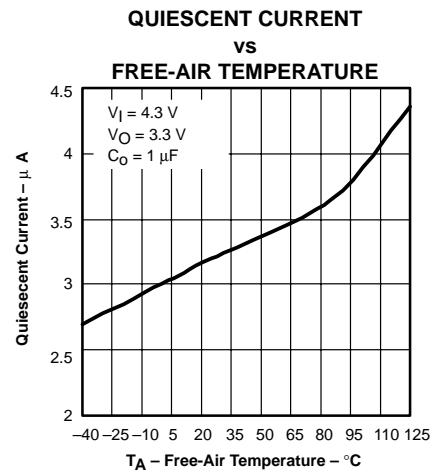

Figure 3

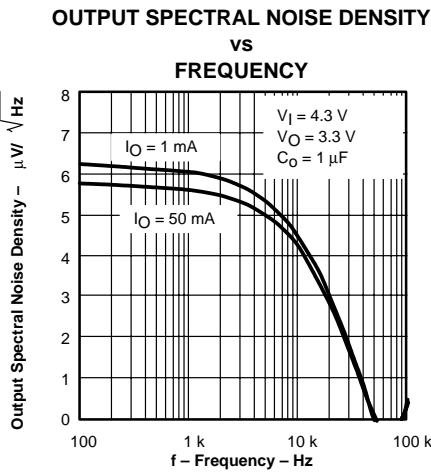

Figure 4

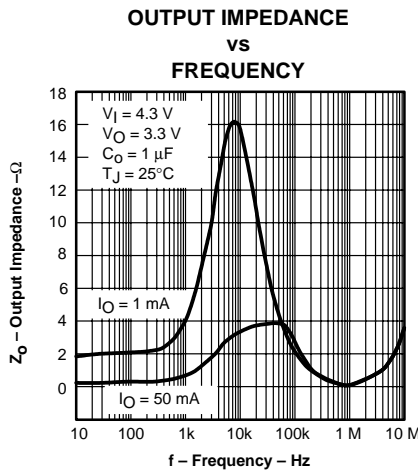

Figure 5

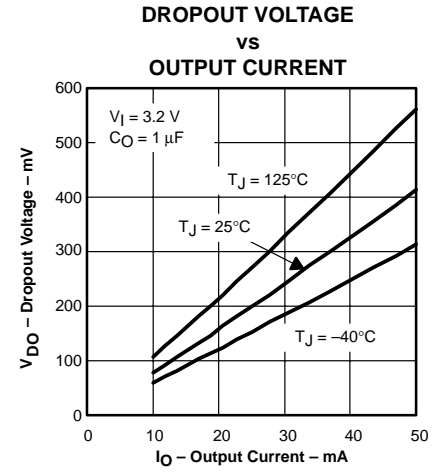

Figure 6

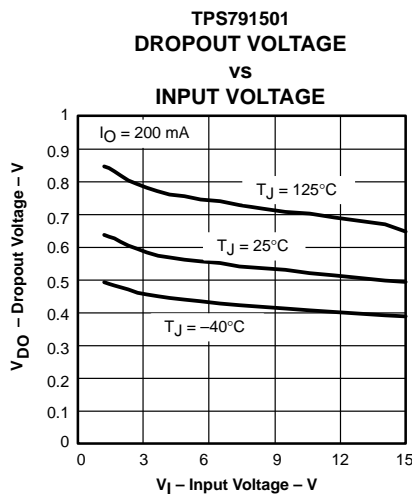

Figure 7

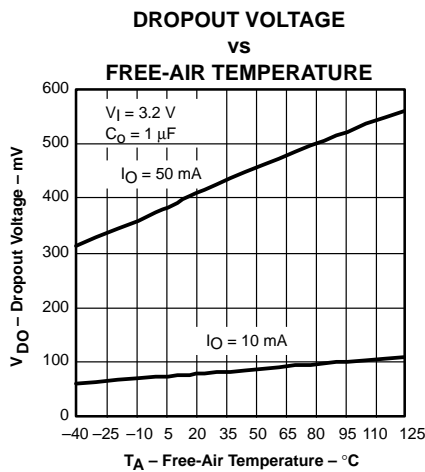

Figure 8

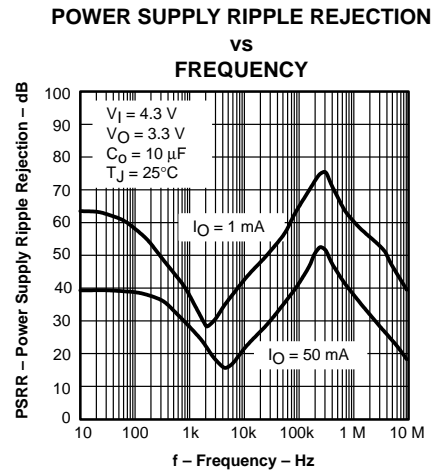

Figure 9

TYPICAL CHARACTERISTICS

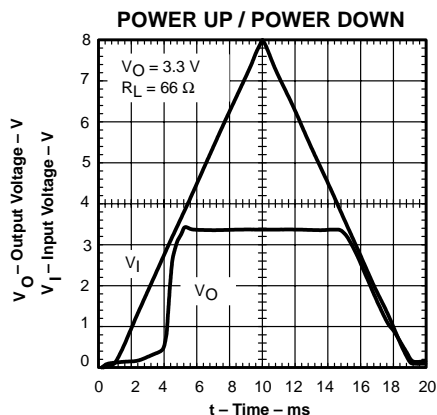

Figure 10

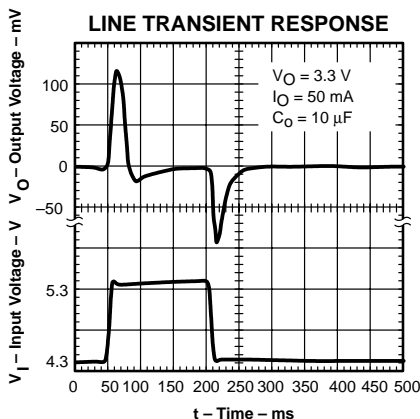

Figure 11

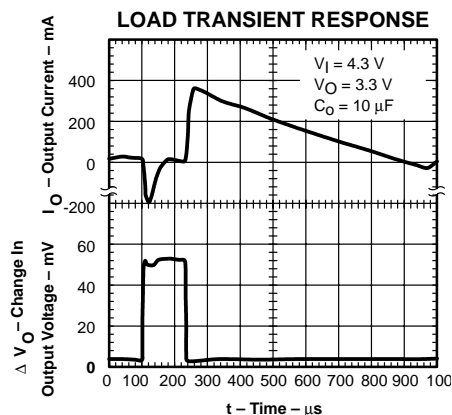

Figure 12

APPLICATION INFORMATION

The TPS715xx family of LDO regulators has been optimized for use with battery management ICs. After the minimum input voltage requirement is met, it is always enabled. The device's maximum input voltage is 24 V. It has a dropout voltage of 415 mV at 50 mA, and its quiescent current is 3.2 μA typically. A typical application circuit is shown in Figure 13.

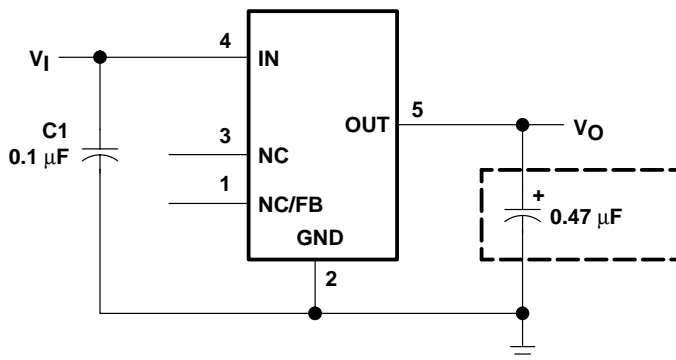

Figure 13. Typical Application Circuit

external capacitor requirements

Although not required, a 0.047- μF or larger input bypass capacitor, connected between IN and GND and located close to the device, is recommended to improve transient response and noise rejection. A higher-value electrolytic input capacitor may be necessary if large, fast-rise-time load transients are anticipated and the device is located several inches from the power source.

Like all low-dropout regulators, the TPS715xx requires an output capacitor connected between OUT and GND to stabilize the internal control loop. The minimum recommended capacitance is 0.47 μF . Any 0.47- μF capacitor is suitable. Capacitor values larger than 0.47 μF are acceptable.

APPLICATION INFORMATION

power dissipation and junction temperature

Specified regulator operation is assured to a junction temperature of 125°C; restrict the maximum junction temperature to 125°C under normal operating conditions. This restriction limits the power dissipation the regulator can handle in any given application. To ensure the junction temperature is within acceptable limits, calculate the maximum allowable dissipation, $P_{D(max)}$, and the actual dissipation, P_D , which must be less than or equal to $P_{D(max)}$.

The maximum-power-dissipation limit is determined using the following equation:

$$P_{D(max)} = \frac{T_{Jmax} - T_A}{R_{\theta JA}}$$

where:

T_{Jmax} is the maximum allowable junction temperature.

$R_{\theta JA}$ is the thermal resistance junction-to-ambient for the package (see the Dissipation Rating Table).

T_A is the ambient temperature.

The regulator dissipation is calculated using:

$$P_D = (V_I - V_O) \times I_O$$

Power dissipation resulting from quiescent current is negligible.

regulator protection

The TPS715xx PMOS-pass transistor has a built-in back diode that conducts reverse current when the input voltage drops below the output voltage (e.g., during power down). Current is conducted from the output to the input and is not internally limited. If extended reverse voltage operation is anticipated, external limiting might be appropriate.

The TPS715xx features internal current limiting. During normal operation, the TPS715xx limits output current to approximately 500 mA. When current limiting engages, the output voltage scales back linearly until the overcurrent condition ends. Take care not to exceed the power dissipation ratings of the package.

programming the TPS71501 adjustable LDO regulator

The output voltage of the TPS71501 adjustable regulator is programmed using an external resistor divider as shown in Figure 14. The output voltage is calculated using:

$$V_O = V_{ref} \times \left(1 + \frac{R1}{R2}\right) \quad (3)$$

where:

$V_{ref} = 1.205$ V typ (the internal reference voltage)

APPLICATION INFORMATION

programming the TPS71501 adjustable LDO regulator (continued)

Resistors R1 and R2 should be chosen for approximately 1.5-μA divider current. Lower value resistors can be used for improved noise performance, but the solution consumes more power. Higher resistor values should be avoided as leakage current into/out of FB across R1/R2 creates an offset voltage that artificially increases/decreases the feedback voltage and thus erroneously decreases/increases V_O. The recommended design procedure is to choose R2 = 1 MΩ to set the divider current at 1.5 μA, and then calculate R1 using:

$$R1 = \left(\frac{V_O}{V_{ref}} - 1 \right) \times R2 \tag{4}$$

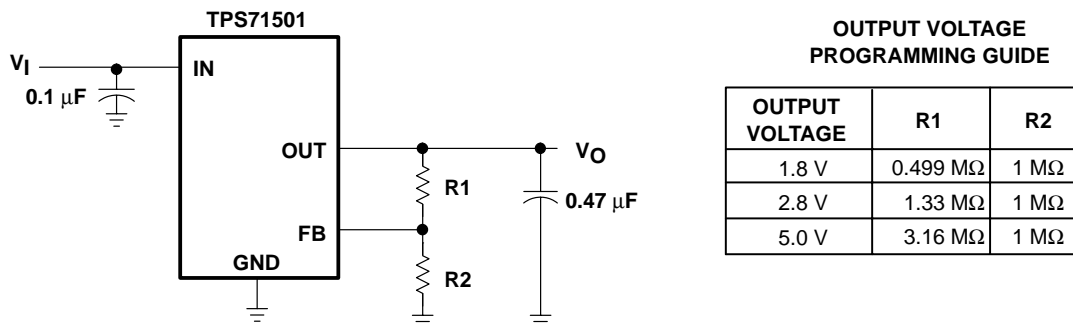

Figure 14. TPS71501 Adjustable LDO Regulator Programming

battery management application

One application for which this device is particularly suited is providing a regulated voltage from a much larger input voltage, as is often the case of ICs used in portable battery-powered devices. Many of the battery management ICs currently on the market monitor battery voltages above 20 V. However, the IC's internal circuitry and peripheral equipment, like an LED's, generally need a lower power bus for operation. Some of the battery management ICs have internal LDO regulator controllers that require five or more external components in order to provide a regulated output voltage. The TPS715xx family has a maximum input voltage rating of 24 V, provides up to 50 mA of output current, and requires only one external component. Therefore, using one of the TPS715xx regulators to power battery management ICs is a much simpler, more compact, and less expensive solution than using onboard LDO regulator controllers. In addition, the TPS715xx family uses only 3.2 μA of quiescent current and does not significantly decrease battery life while the device is inactive.

TI's bq2060 gas gauge IC was chosen to demonstrate the use of the TPS71533. The bq2060 battery management IC requires a regulated 3.3 V for normal operation. The bq2060 has a regulator controller output (REG) that, when used in conjunction with an external JFET (Q2), a bipolar transistor (Q1), two capacitors (C1 and C2), and one resistor (R1), forms a 3.3-V output linear regulator as shown in Figure 15.

APPLICATION INFORMATION

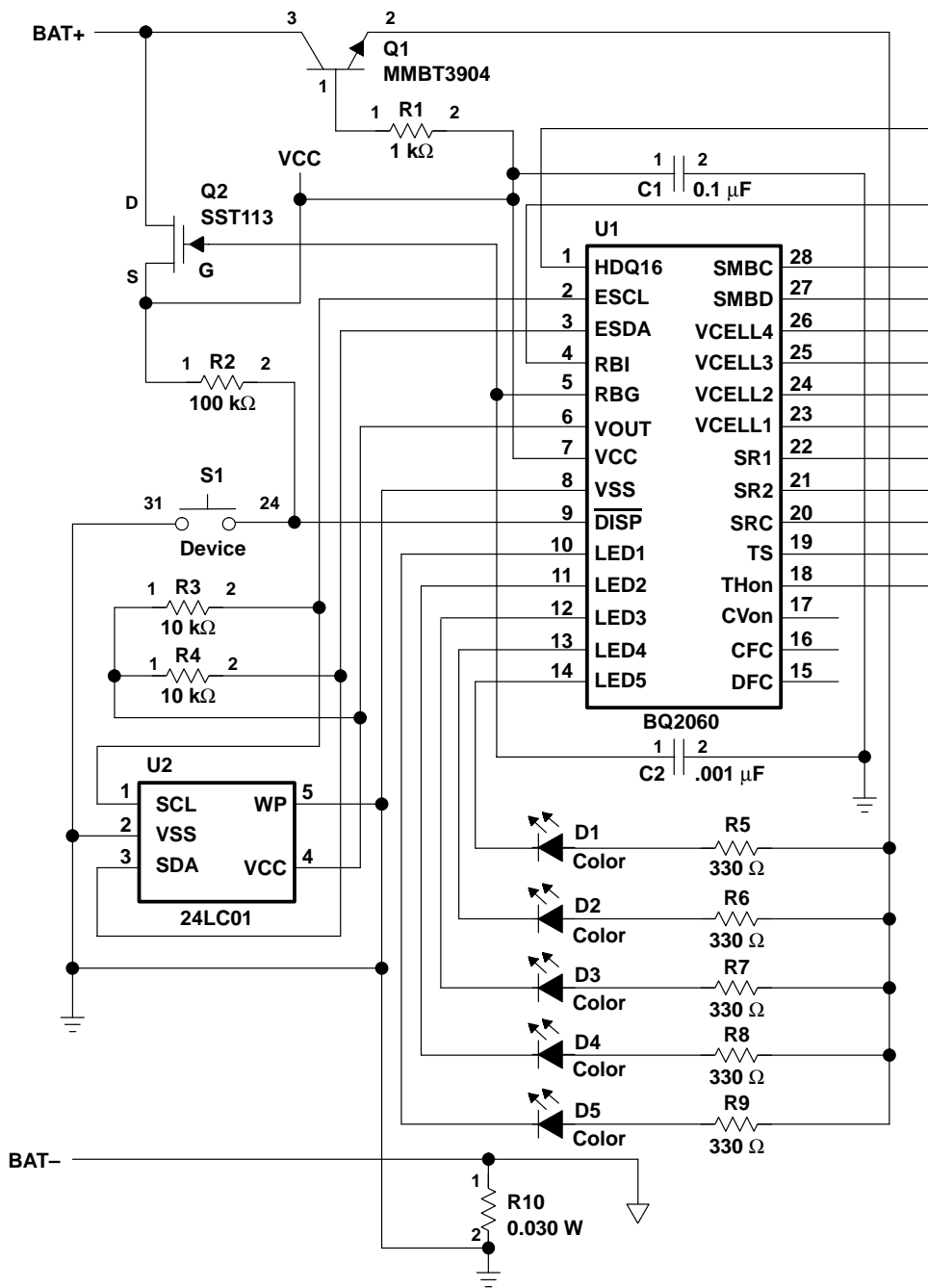

Figure 15. bq2060 Powered With Internal LDO Controller

APPLICATION INFORMATION

However, with five external components, this regulator is more complex and costly than using a separate LDO regulator. Figure 16 shows the TPS71533 and its external output capacitor (C1) providing the regulated 3.3 V to the bq2060.

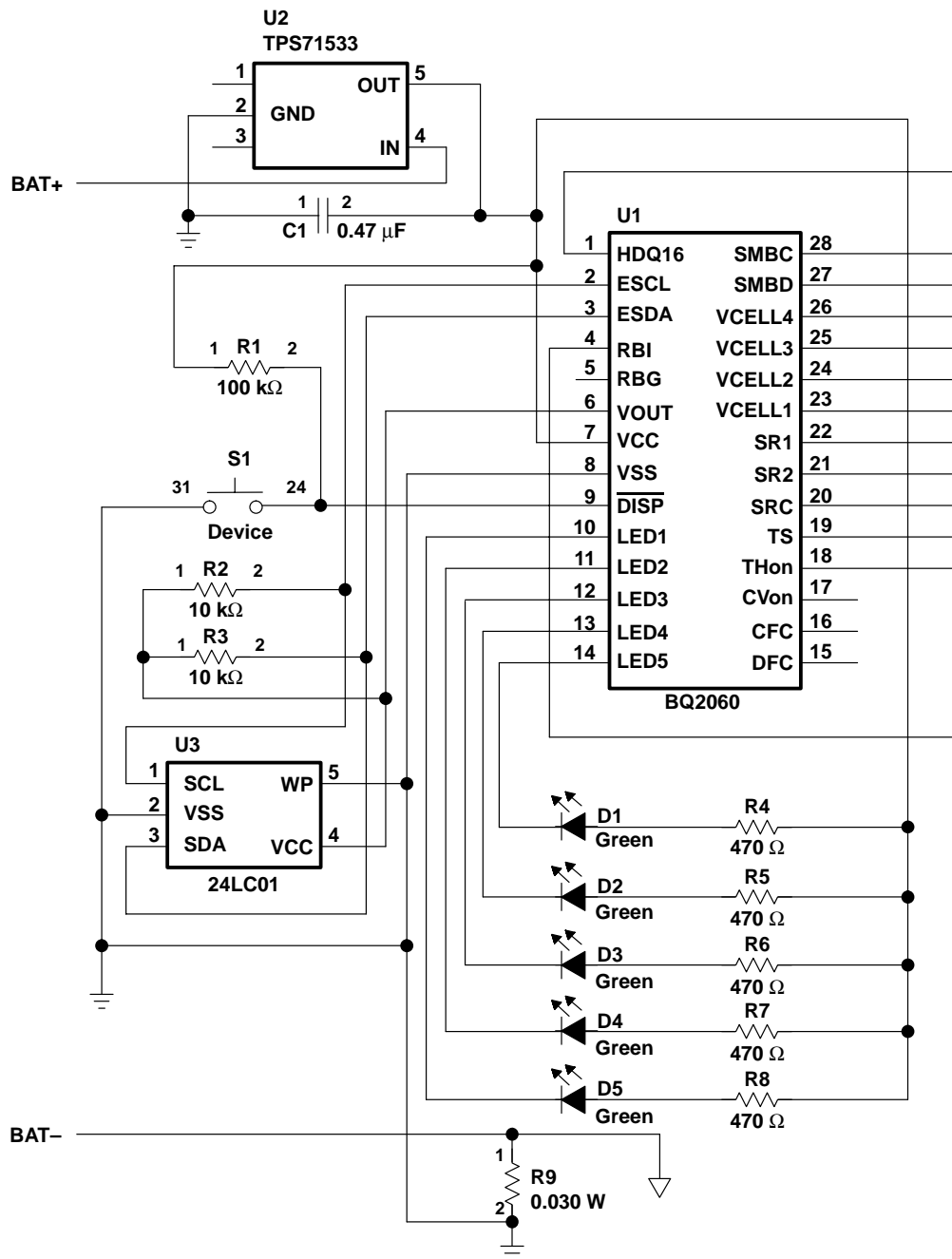

Figure 16. bq2060 Powered With TPS71533

APPLICATION INFORMATION

In Figure 16, the bq2060 is configured to monitor 4 Li-Ion batteries in series totaling 16.8 V. During either battery charging or discharging, the maximum current that the bq2060 requires from the TPS71533 occurs when the user presses the push button (S1) and potentially activates all five LEDs, indicating a fully charged battery. The LEDs require 3 mA each and remain on for 4 seconds and then off for 2 seconds. Therefore, the bq2060 potentially requires a total of 15 mA for 67% duty cycle and thus the total power dissipated by the TPS71533 would not exceed 136 mW $[(16.8 \text{ V} - 3.3 \text{ V}) \times 15 \text{ mA} \times 67\%]$. Therefore, power dissipation is not a concern in this application. When the LEDs are not activated, the bq2060 only requires approximately 200- μ A quiescent current. For more information on the operation of the bq2060, refer to the data sheet (TI literature number SLUS035). An evaluation module with a similar configuration to the one shown in Figure 16 is also available (TI literature number SLUU063).

MECHANICAL DATA

DCK (R-PDSO-G5)

PLASTIC SMALL-OUTLINE

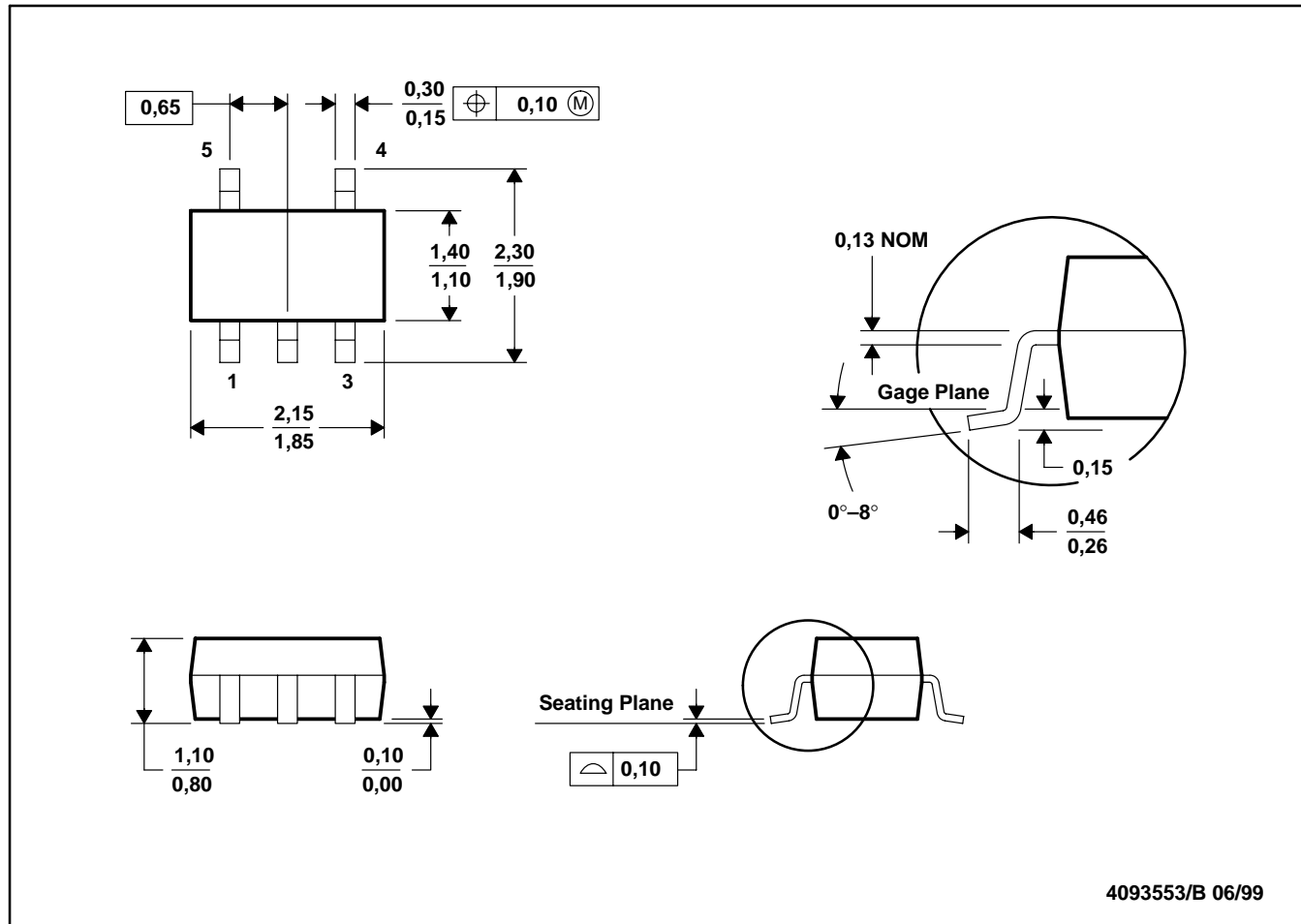

4093553/B 06/99

- NOTES: A. All linear dimensions are in millimeters.
 B. This drawing is subject to change without notice.
 C. Body dimensions do not include mold flash or protrusion.
 D. Falls within JEDEC MO-203

IMPORTANT NOTICE

Texas Instruments Incorporated and its subsidiaries (TI) reserve the right to make corrections, modifications, enhancements, improvements, and other changes to its products and services at any time and to discontinue any product or service without notice. Customers should obtain the latest relevant information before placing orders and should verify that such information is current and complete. All products are sold subject to TI's terms and conditions of sale supplied at the time of order acknowledgment.

TI warrants performance of its hardware products to the specifications applicable at the time of sale in accordance with TI's standard warranty. Testing and other quality control techniques are used to the extent TI deems necessary to support this warranty. Except where mandated by government requirements, testing of all parameters of each product is not necessarily performed.

TI assumes no liability for applications assistance or customer product design. Customers are responsible for their products and applications using TI components. To minimize the risks associated with customer products and applications, customers should provide adequate design and operating safeguards.

TI does not warrant or represent that any license, either express or implied, is granted under any TI patent right, copyright, mask work right, or other TI intellectual property right relating to any combination, machine, or process in which TI products or services are used. Information published by TI regarding third-party products or services does not constitute a license from TI to use such products or services or a warranty or endorsement thereof. Use of such information may require a license from a third party under the patents or other intellectual property of the third party, or a license from TI under the patents or other intellectual property of TI.

Reproduction of information in TI data books or data sheets is permissible only if reproduction is without alteration and is accompanied by all associated warranties, conditions, limitations, and notices. Reproduction of this information with alteration is an unfair and deceptive business practice. TI is not responsible or liable for such altered documentation.

Resale of TI products or services with statements different from or beyond the parameters stated by TI for that product or service voids all express and any implied warranties for the associated TI product or service and is an unfair and deceptive business practice. TI is not responsible or liable for any such statements.

Mailing Address:

Texas Instruments
Post Office Box 655303
Dallas, Texas 75265