



HIGH-PERFORMANCE INTEGER-N PLL FREQUENCY SYNTHESIZER

FEATURES

- **Single Device Covers Frequencies Up to 2.4 GHz**
- **Dual Supply Range: 3 V – 3.6 V and 4.5 V – 5.5 V**
- **Separate Charge Pump Supply (V_{CP}) Up to 8 V**
- **Simple 3-Wire Serial Interface Allows for Fully Programmable:**
 - A, B, and R Counters
 - Dual Modulus Prescaler [8/9, 16/17, 32/33, and 64/65]
 - Charge Pump Current
- **Lock Detect Output (Digital and Analog)**
- **Versatile Hardware and Software Power Down**
- **Packaged in a 16-Pin TSSOP Thin Quad FlatPack and a 20-Pin 4 x 4 mm QFN Package**

APPLICATIONS

- **Wireless Infrastructure**
 - GSM, IS136, EDGE/UWC-136
 - IS95, UMTS, CDMA2000
- **Portable Wireless Communications**
- **Wireless LAN**
- **Wireless Transceivers**
- **Communication Test Equipment**

DESCRIPTION

The TRF3750 frequency synthesizer is ideal for designing the local oscillator portion of wireless transceivers by providing complete programmability and ultra-low phase noise. The device features a user-selectable dual-modulus prescaler, a 14-bit reference (R) divider, a 6-bit A,

and a 13-bit B counter. The R divider allows the user to select the frequency of choice for the phase-frequency detector (PFD) circuit, and with the use of the counters implement an N divider of value $N = A + P \times B$. With an extended charge-pump supply (V_{CP}) of up to 8 V, a wide variety of external VCOs can be used to complete the phase-locked loop. Ultra-low phase noise and reference spur performance make the TRF3750 ideal for generating the local oscillator in the most demanding wireless applications.

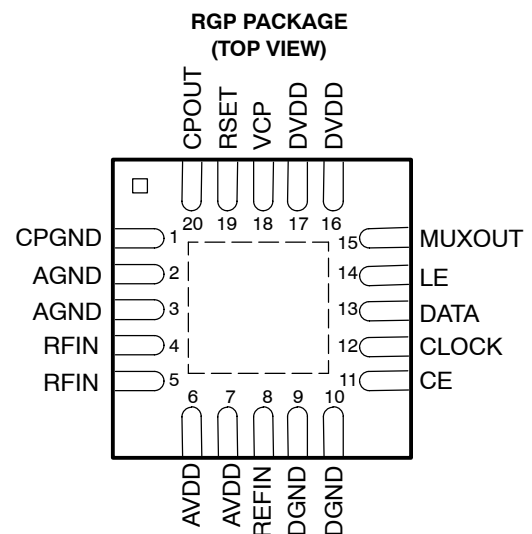
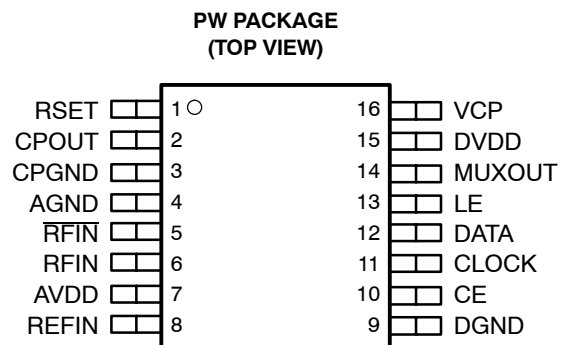

Please be aware that an important notice concerning availability, standard warranty, and use in critical applications of Texas Instruments semiconductor products and disclaimers thereto appears at the end of this data sheet.



This integrated circuit can be damaged by ESD. Texas Instruments recommends that all integrated circuits be handled with appropriate precautions. Failure to observe proper handling and installation procedures can cause damage.

ESD damage can range from subtle performance degradation to complete device failure. Precision integrated circuits may be more susceptible to damage because very small parametric changes could cause the device not to meet its published specifications.

FUNCTIONAL BLOCK DIAGRAM FOR TSSOP PACKAGE

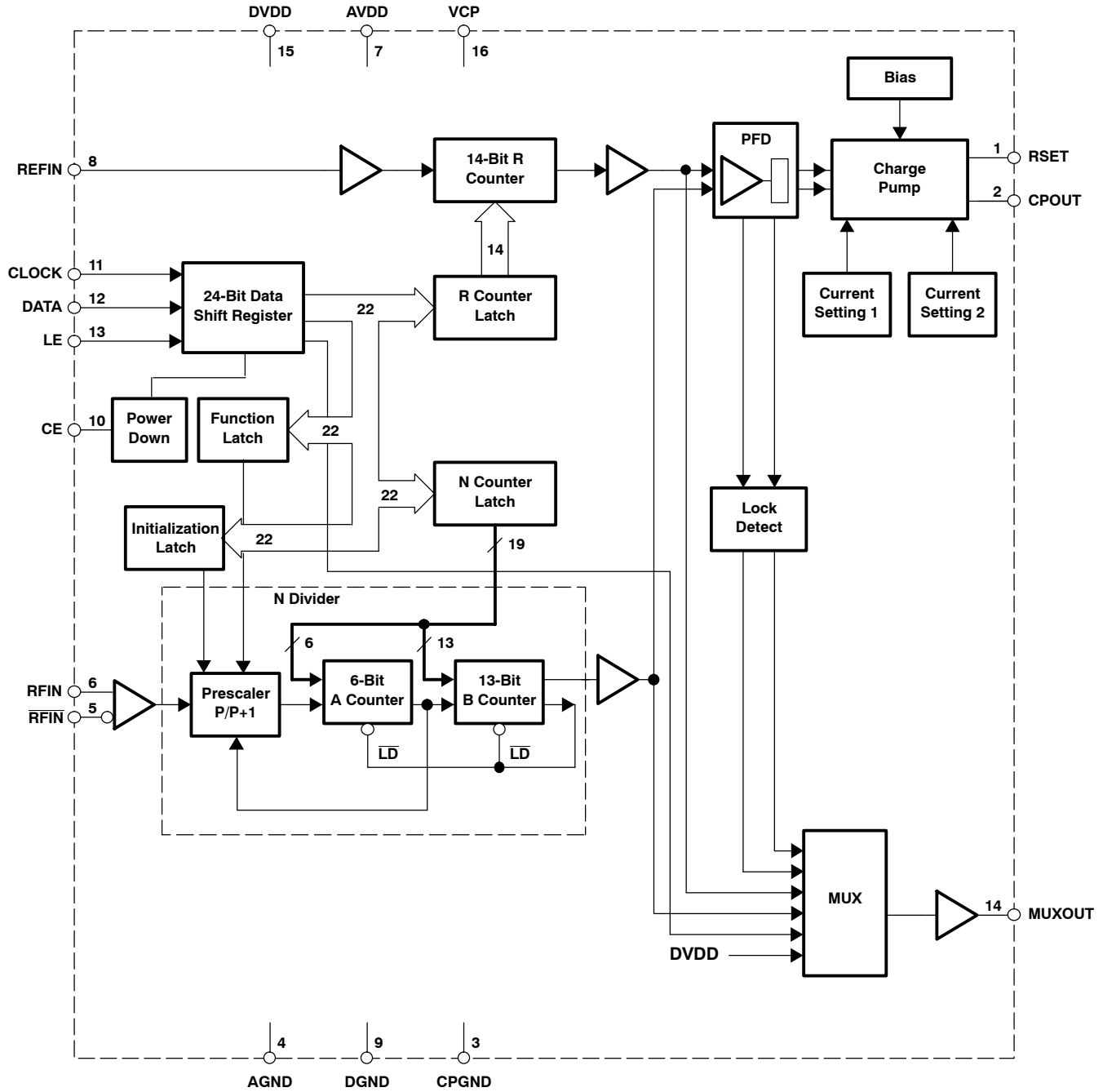

ORDERING INFORMATION

PRODUCT	PACKAGE / LEADS	PACKAGE DESIGNATOR	SPECIFIED TEMPERATURE RANGE	PACKAGE MARKING	ORDERING NUMBER	TRANSPORT MEDIA	QUANTITY
TRF3750IPW	TSSOP-16	PW	–40°C to 85°C	TRF3750	TRF3750IPW	Tube	90
TRF3750IPWR	TSSOP-16	PW	–40°C to 85°C	TRF3750	TRF3750IPWR	Reel	2000
TRF3750IRGP	QFN-20	RGP	–40°C to 85°C	TRF3750	TRF3750IRGP	Tube	91
TRF3750IRGPR	QFN-20	RGP	–40°C to 85°C	TRF3750	TRF3750IRGPR	Reel	1000

PIN ASSIGNMENTS

TERMINAL			TYPE	DESCRIPTION
NAME	QFN ⁽¹⁾ NO.	TSSOP NO.		
R _{SET}	19	1	O	The user needs to place an external resistor (R _{SET}) from this pin to ground to control the maximum charge pump current. This node's output voltage is typically around 1 V and the relationship between I _{CPOUTmax} and R _{SET} is: $I_{CPOUTmax} = \frac{23.5}{R_{SET}}$ A 4.7-kΩ resistor placed at this pin to ground would hence provide a maximum charge pump output current of approximately 5 mA.
CPOUT	20	2	O	Charge pump output. This node provides the charge pump current that ultimately controls the external VCO.
CPGND	1	3	I	Charge pump ground
AGND	23	4	I	Analog ground
R _{FIN}	4	5	I	Complementary input to the prescaler. For single-ended applications, bypass with a small capacitor to ground (typically 100 pF).
RFIN	5	6	I	Input to the prescaler. To complete the PLL, this signal must come from the output of the external VCO.
AVDD	6, 7	7	I	Analog power supply. There are two possible supply ranges: 3 V – 3.6 V and 4.5 V – 5.5 V. This value should be the same as the DVDD. Appropriate decoupling is necessary for optimal performance.
REFIN	8	8	I	Reference frequency input. This externally provided reference gets divided by the selectable R divider, and is used to synthesize the desired output frequency. Typically this input is an ac-coupled sinusoid; however, a TTL or CMOS signal can also be used.
DGND	9, 10	9	I	Digital ground
CE	11	10	I	Chip enable. Setting this pin low puts the device into power down; setting it high activates the charge pump if the software controlled power down is also disabled.
CLOCK	12	11	I	Serial clock input. This is the input that is used to clock the serial data into the 24-bit shift register of the device. The data is read at the rising edge of this clock.
DATA	13	12	I	Serial data input. This is the data stream that contains the data to be loaded into the shift register. The data is loaded MSB first.
LE	14	13	I	Load enable. When this asynchronous signal is asserted high, the data existing in the shift register get loaded onto the selected latch.
MUXOUT	15	14	O	This user-selectable output can be controlled to provide the digital or analog lock detect signals, the divide by N RF signal or the divide by R reference. The output can also be 3-stated.
DVDD	16, 17	15	I	Digital power supply. There are two possible supply ranges: 3 V – 3.6 V and 4.5 V – 5.5 V. This value should be the same as the AVDD. Appropriate decoupling is necessary for optimal performance.
VCP	18	16	I	Charge pump supply. This supply must be <i>at least</i> 1 V greater than the AVDD and DVDD and can be as high as 8 V, accommodating a large range of possible VCOs.

⁽¹⁾ The thermal pad on the bottom of the QFN package may be tied to ground, but is not required to meet specified performance.

ABSOLUTE MAXIMUM RATINGSover operating free-air temperature range unless otherwise noted⁽¹⁾

		UNIT
Supply voltage range ⁽²⁾	AVDD	-0.3 V to 6.5 V
	AVDD to DVDD	-0.3 V to 0.3 V
	VCP to AGND	-0.3 V to 9 V
Digital I/O voltage to DGND (DGND = 0 V)		-0.3 V to 6.5 V
Reference signal input	REFIN to DGND	-0.3 V to DVDD + 0.3 V
RF prescaler input	RFIN, \overline{RFIN} to AGND	-0.3 V to 6.5 V
Continuous power dissipation		See Dissipation Rating Table
Storage temperature, T_{Stg}		-65°C to 150°C
Lead temperature 1,6 mm (1/16 inch) from case for 10 seconds		260°C

(1) Stresses beyond those listed under "absolute maximum ratings" may cause permanent damage to the device. These are stress ratings only, and functional operation of the device at these or any other conditions beyond those indicated under "recommended operating conditions" is not implied. Exposure to absolute-maximum-rated conditions for extended periods may affect device reliability.

(2) All voltage values are with respect to network ground terminal.

DISSIPATION RATING TABLE

PACKAGE	$T_A \leq 25^\circ\text{C}$	DERATING FACTOR ⁽¹⁾ ABOVE $T_A = 25^\circ\text{C}$	$T_A = 85^\circ\text{C}$ POWER RATING
16-pin TSSOP	2780 mW	22.2 mW/°C	1440 mW
20-pin QFN	2780 mW	29 mW/°C	1440 mW

(1) This is the inverse of the junction-to-ambient thermal resistance when board mounted and with no airflow.

RECOMMENDED OPERATING CONDITIONS

		MIN	NOM	MAX	UNIT
Supply voltage	AVDD = DVDD, 3.3 V range	3	3.3	3.6	V
	AVDD = DVDD, 5 V range	4.5	5	5.5	V
	VCP	(AVDD, DVDD) + 1		8	V
High-level input voltage, V_{IH}	LE, DATA, CLK, CE	0.8 × DVDD			V
Low-level input voltage, V_{IL}				0.2 × DVDD	V
High-level output voltage, V_{OH}	MUXOUT	DVDD - 0.4			V
Low-level output voltage, V_{OL}				0.4	V
Operating free-air temperature, T_A		-40		85	°C

ELECTRICAL CHARACTERISTICS

Conditions: (AVDD = DVDD = 3.3 V or 5 V, AVDD + 1 ≤ VCP ≤ 8 V, R_{SET} = 4.7 kΩ, T_A = -40°C to 85°C, REFIN = 10 MHz at +5 dBm) (unless otherwise stated)

PARAMETER		TEST CONDITIONS	MIN	TYP	MAX	UNIT
I _{AVDD}	Supply current	AVDD = 3.3 V		10		mA
		AVDD = 5 V		13		
I _{DVDD}	Supply current	DVDD = 3.3 V		3		mA
		DVDD = 5 V		3.5		
I _{VCP}	Supply current	VCP = 7 V		7.5		mA
	REFIN input frequency (RF input)				2400	MHz
	REFIN input power level		-15		+5	dBm
	RF prescaler output frequency ⁽¹⁾				200	MHz
	REFIN input frequency (reference input) ⁽¹⁾		4		350	MHz
	REFIN input power level sensitivity			-10		dBm
	REFIN input capacitance			5		pF
	PFD maximum frequency ⁽¹⁾				60	MHz
I _{CPOUTmax}	Charge pump max source current			5		mA
I _{CPOUTmin}	Charge pump max sink current			-5		mA
VTUNE	Output tuning voltage ⁽²⁾	Measured at the output of the external loop filter, in locked condition	1		VCP-1.1	V

⁽¹⁾ Assured by design.

⁽²⁾ VTUNE range shown is for optimal spurious performance; the device can function beyond these limits.

ELECTRICAL CHARACTERISTICS

Conditions (unless otherwise stated): AVDD = DVDD = 3.3 V or 5 V, VCP = 7 V; R_{SET} = 4.7 k Ω , T_A = 27°C, REFIN = 10 MHz at 6.5 dBm Referenced to 50 Ω , I_{CPOUTmax} = 5 mA, Power Down: Normal Operation; Timer Counter Control: Not used; MUXOUT Control: 3-state; Fast Lock Mode: Disabled, PFD Polarity: Positive, Anti-backlash Pulse width: 1.5 ns, Resync/Delay: Normal (Delay=0, Resync=0), Counter Operation: Normal, Charge Pump Output: Normal, Lock Detect Precision: 5 cycles

PARAMETER	TEST CONDITIONS	MIN	TYP	MAX	UNIT
Phase noise 110 MHz)	PFD = 200 kHz, Loop Loop BW = 20 kHz, N = 550, Phase noise measured at 1-kHz offset spurs measured at \pm PFD, $\pm 2 \times$ PFD	-106			dBc/Hz
Reference spurs 110 MHz		-110			dBc
Phase noise 300 MHz	PFD = 200 kHz, Loop Loop BW = 20 kHz, N = 1500, Phase noise measured at 1-kHz offset spurs measured at \pm PFD, $\pm 2 \times$ PFD	-99			dBc/Hz
Reference spurs 300 MHz		-110			dBc
Phase noise 540 MHz	PFD = 200 kHz, Loop Loop BW = 20 kHz, N = 2700, Phase noise measured at 1-kHz offset spurs measured at \pm PFD, $\pm 2 \times$ PFD	-94			dBc/Hz
Reference spurs 540 MHz		-90			dBc
Phase noise 836 MHz	PFD = 200 kHz, Loop Loop BW = 20 kHz, N = 4180, Phase noise measured at 1-kHz offset spurs measured at \pm PFD, $\pm 2 \times$ PFD	-91			dBc/Hz
Reference spurs 836 MHz		-100			dBc
Phase noise 900 MHz	PFD = 200 kHz, Loop Loop BW = 20 kHz, N = 4500, Phase noise measured at 1-kHz offset spurs measured at \pm PFD, $\pm 2 \times$ PFD	-91			dBc/Hz
Phase noise 900 MHz, over temperature and supply		-90			
Reference spurs 900 MHz	PFD = 200 kHz, Loop Loop BW = 20 kHz, N = 4500, Phase noise measured at 1-kHz offset spurs measured at \pm PFD, $\pm 2 \times$ PFD	-100			dBc
Reference spurs 900 MHz, over temperature and supply		-100			dBc
Phase noise 1750 MHz	PFD = 200 kHz, Loop Loop BW = 20 kHz, N = 8750 Phase noise measured at 1-kHz offset spurs measured at \pm PFD, $\pm 2 \times$ PFD	-84			dBc/Hz
Reference spurs 1750 MHz		-96			dBc
Phase noise 1960 MHz	PFD = 200 kHz, Loop Loop BW = 20 kHz, N = 9800, Phase noise measured at 1-kHz offset spurs measured at \pm PFD, $\pm 2 \times$ PFD	-84			dBc/Hz
Phase noise 1960 MHz, over temperature and supply		-82			
Reference spurs 1960 MHz	PFD = 200 kHz, Loop Loop BW = 20 kHz, N = 9800, Phase noise measured at 1-kHz offset spurs measured at \pm PFD, $\pm 2 \times$ PFD	-90			dBc
Reference spurs 1960 MHz, over temperature and supply		-90			dBc
Phase noise 2200 MHz	PFD = 200 kHz, Loop Loop BW = 20 kHz, N = 11000, Phase noise measured at 1-kHz offset spurs measured at \pm PFD, $\pm 2 \times$ PFD	-83			dBc/Hz
Reference spurs 2200 MHz		-90			dBc

PRODUCT TIMING CHARACTERISTICS

AVDD = DVDD = 3.3 V ±10% or 5 V ±10% , T_A = -40°C to 85°C (unless otherwise stated)

PARAMETER	TEST CONDITIONS	MIN	TYP	MAX	UNIT
t _(CLK) Clock period ⁽¹⁾		50			ns
t _{su1} Data setup time ⁽²⁾		10			ns
t _h Data hold time ⁽²⁾		10			ns
t _w LE pulse width ⁽²⁾		20			ns
t _{su2} LE setup time ⁽²⁾		10			ns

(1) Production tested.

(2) Assured by design.

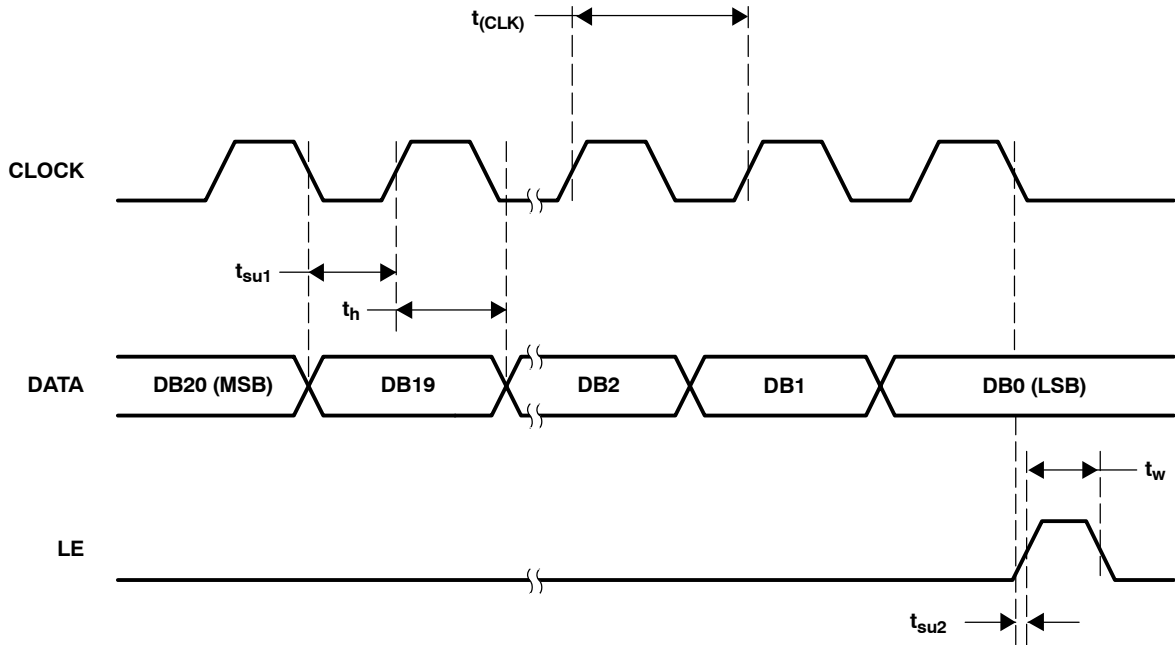
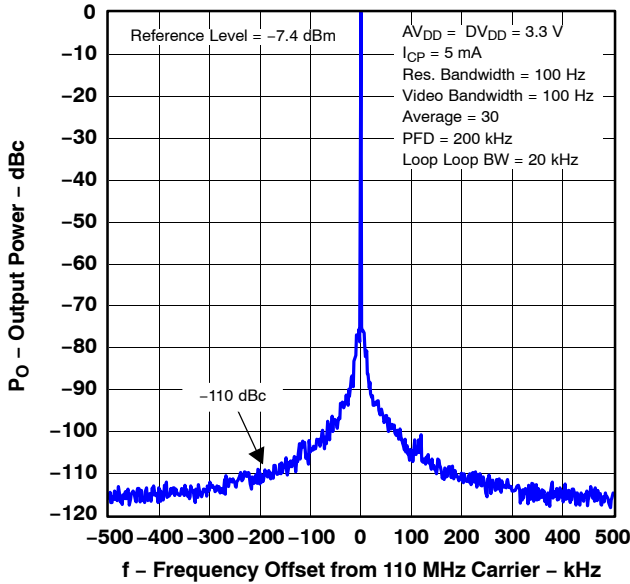

Figure 1. Serial Programming Timing Diagram

TYPICAL CHARACTERISTICS

(Conditions are based on *Electrical Characteristics* table on page 6, unless otherwise noted)

**OUTPUT POWER
vs
FREQUENCY**



**Figure 2. Reference Spurs
(RFOUT = 110 MHz)**

**PHASE NOISE
vs
FREQUENCY**

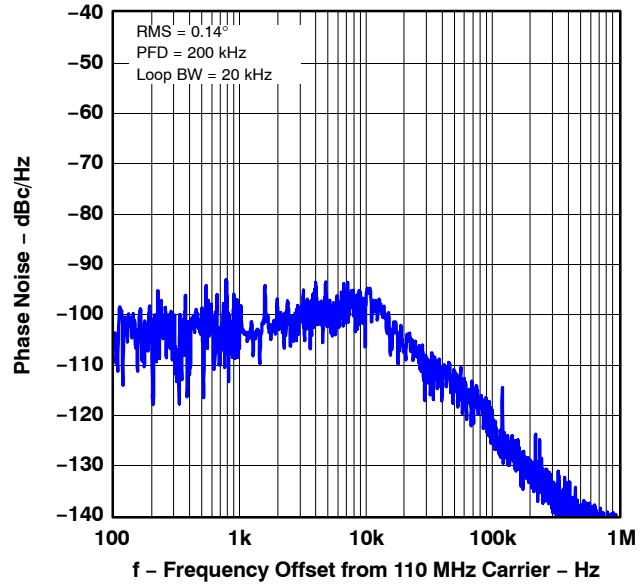

**Figure 3. Integrated Phase Noise
(RFOUT = 110 MHz)**

**OUTPUT POWER
vs
FREQUENCY**

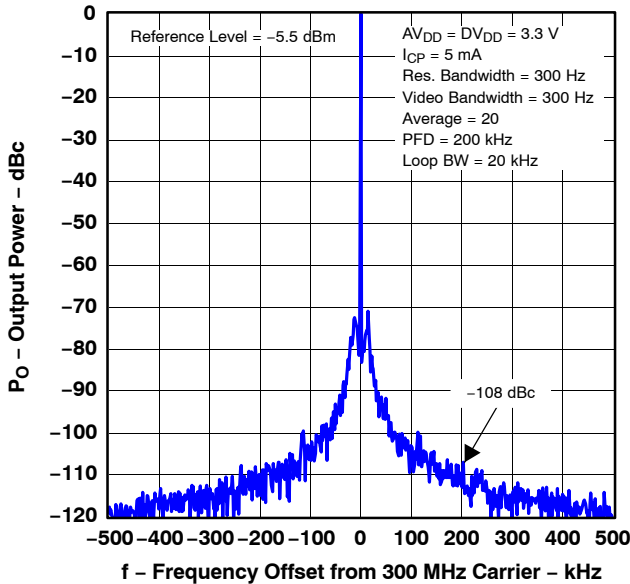

**Figure 4. Reference Spurs
(RFOUT = 300 MHz)**

**PHASE NOISE
vs
FREQUENCY**

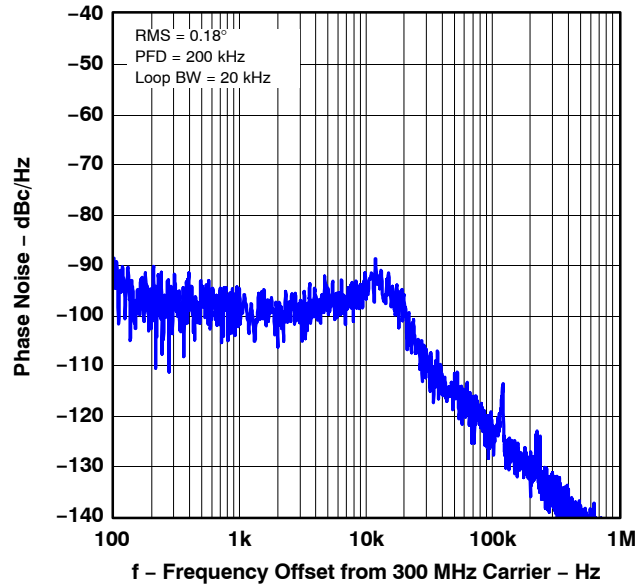

**Figure 5. Integrated Phase Noise
(RFOUT = 300 MHz)**

TYPICAL CHARACTERISTICS

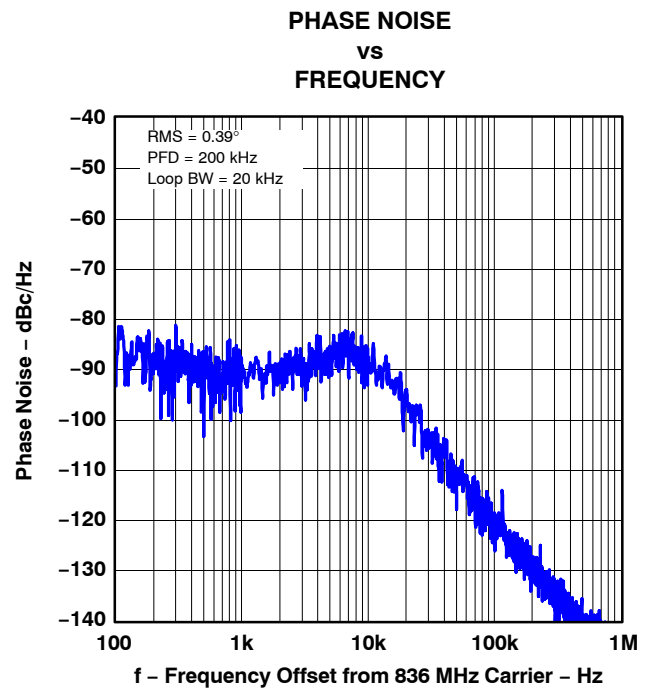
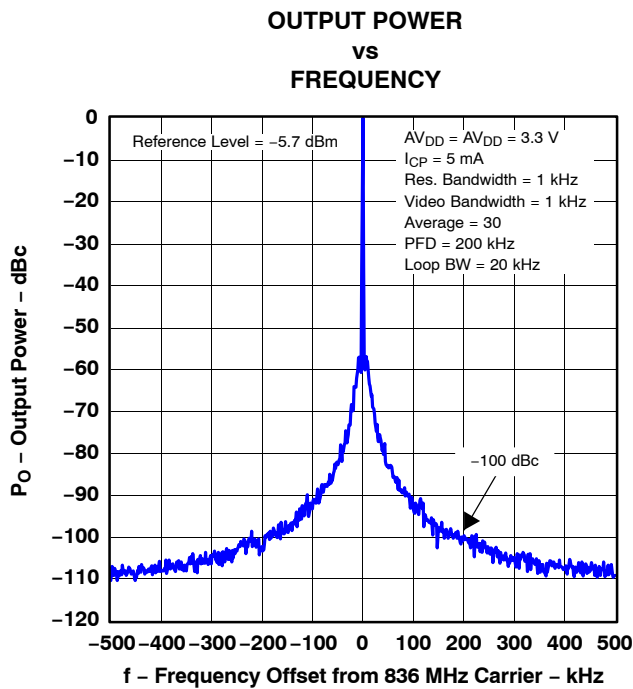
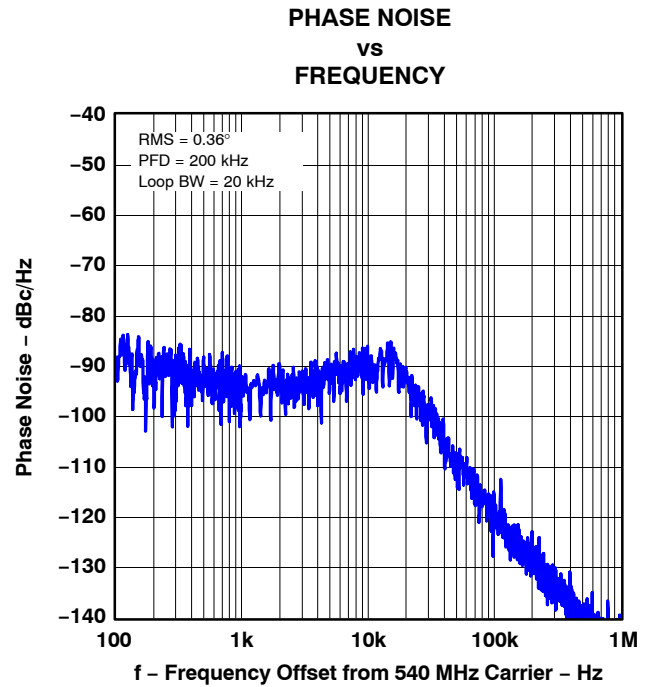
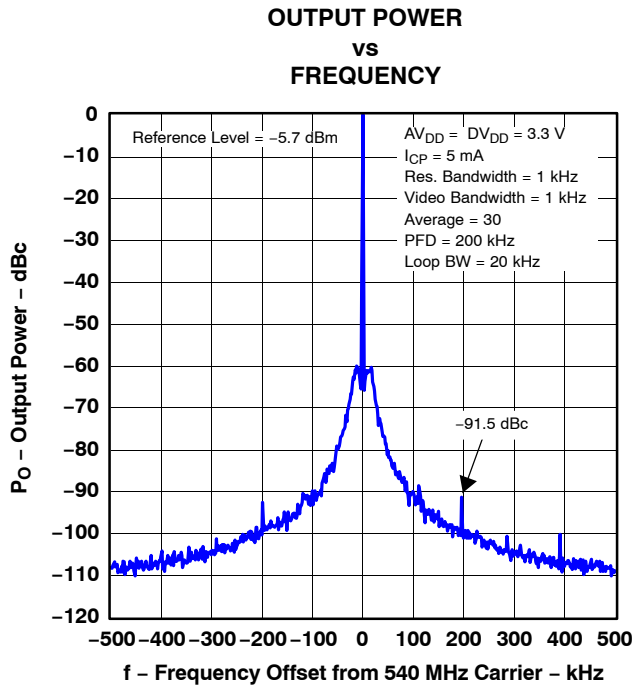

TYPICAL CHARACTERISTICS

OUTPUT POWER
vs
FREQUENCY

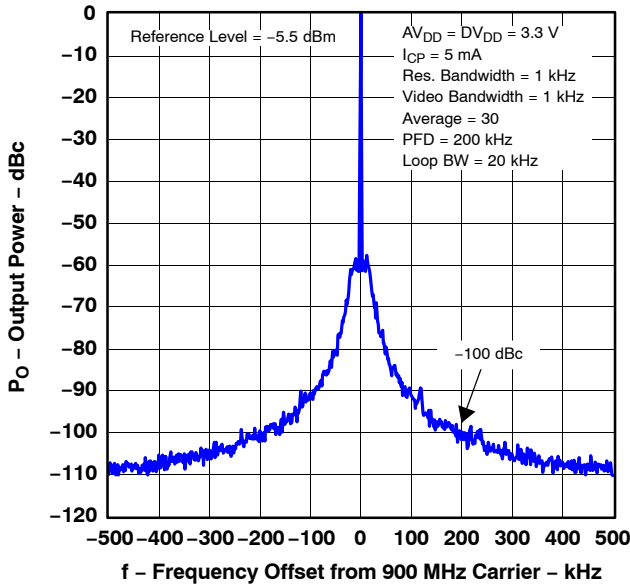

Figure 10. Reference Spurs
(RFOUT = 900 MHz)

OUTPUT POWER
vs
FREQUENCY

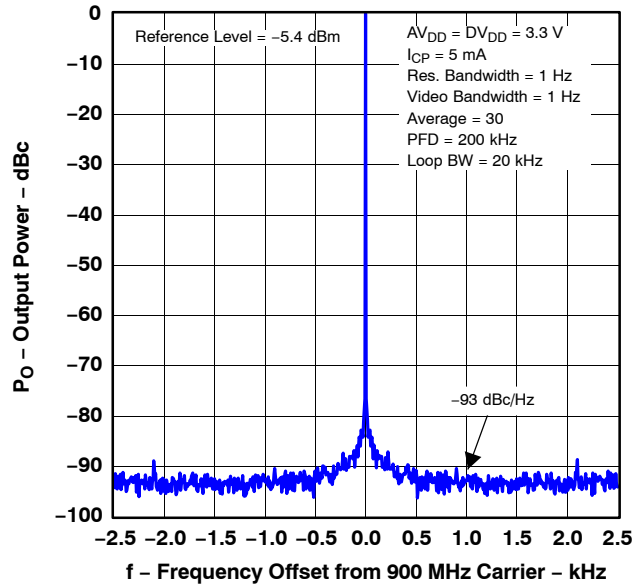

Figure 11. Phase Noise
(RFOUT = 900 MHz)

PHASE NOISE
vs
FREQUENCY

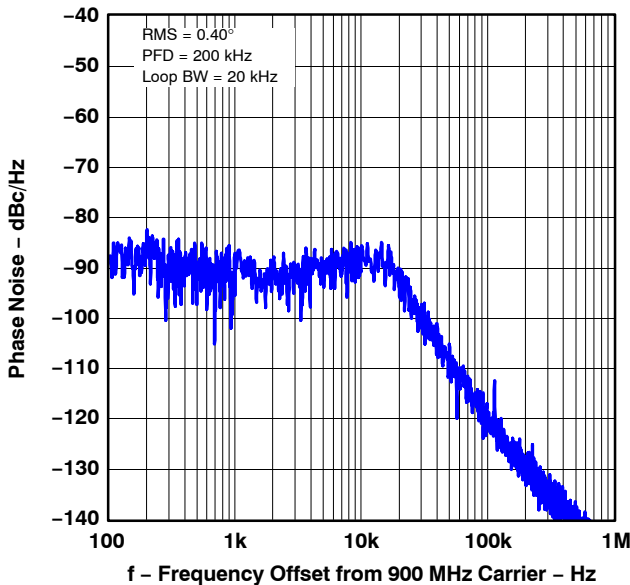

Figure 12. Integrated Phase Noise
(RFOUT = 900 MHz)

OUTPUT POWER
vs
FREQUENCY

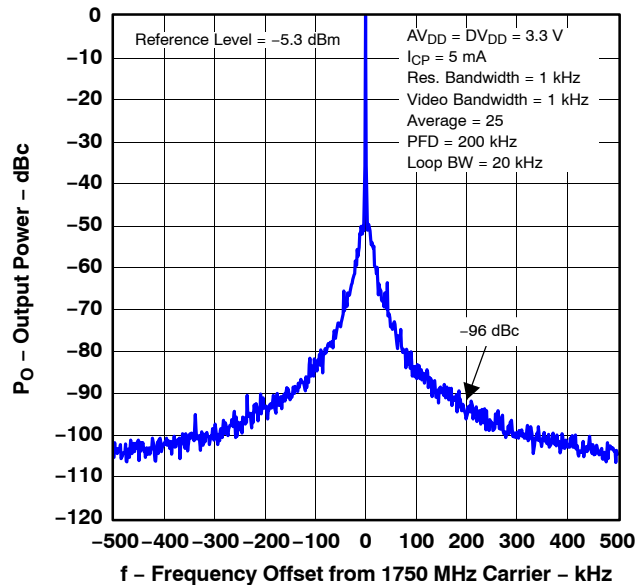

Figure 13. Reference Spurs
(RFOUT = 1750 MHz)

TYPICAL CHARACTERISTICS

PHASE NOISE
vs
FREQUENCY

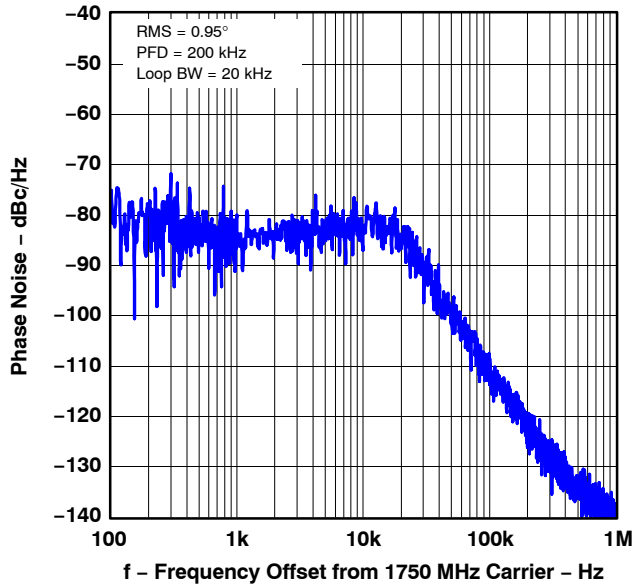

Figure 14. Phase Noise
(RFOUT = 1750 MHz)

OUTPUT POWER
vs
FREQUENCY

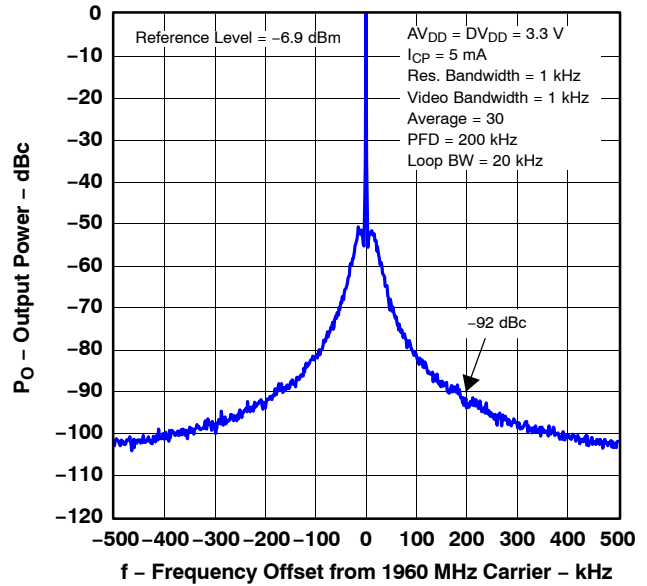

Figure 15. Reference Spurs
(RFOUT = 1960 MHz)

OUTPUT POWER
vs
FREQUENCY

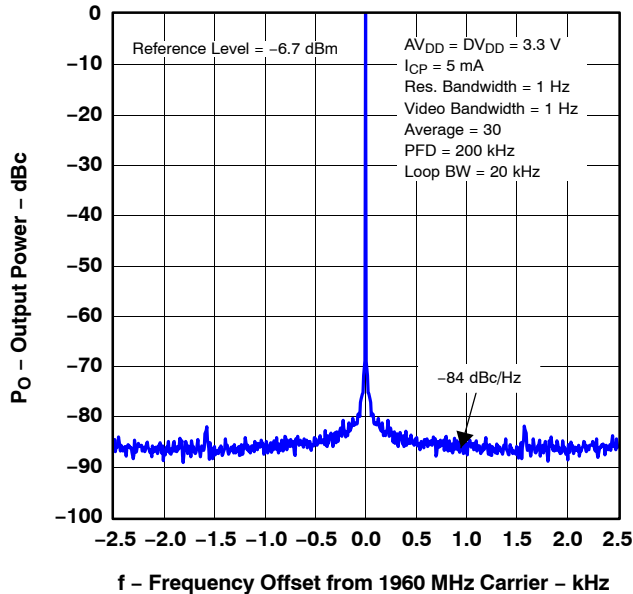

Figure 16. Phase Noise
(RFOUT = 1960 MHz)

PHASE NOISE
vs
FREQUENCY

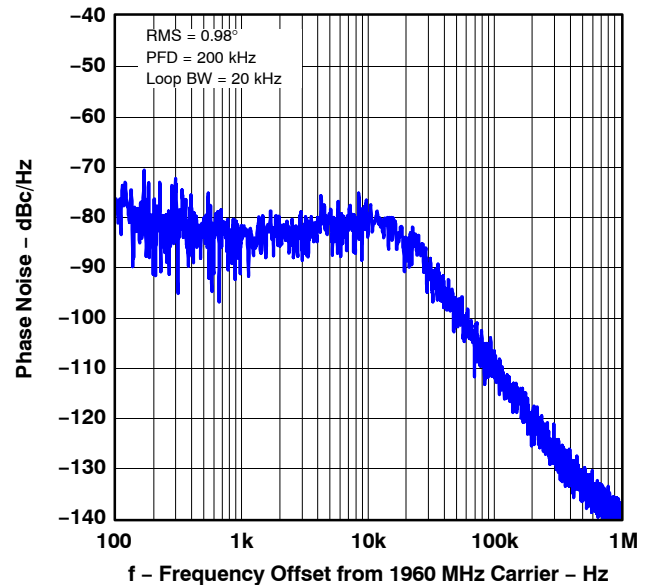

Figure 17. Integrated Phase Noise
(RFOUT = 1960 MHz)

TYPICAL CHARACTERISTICS

OUTPUT POWER
vs
FREQUENCY

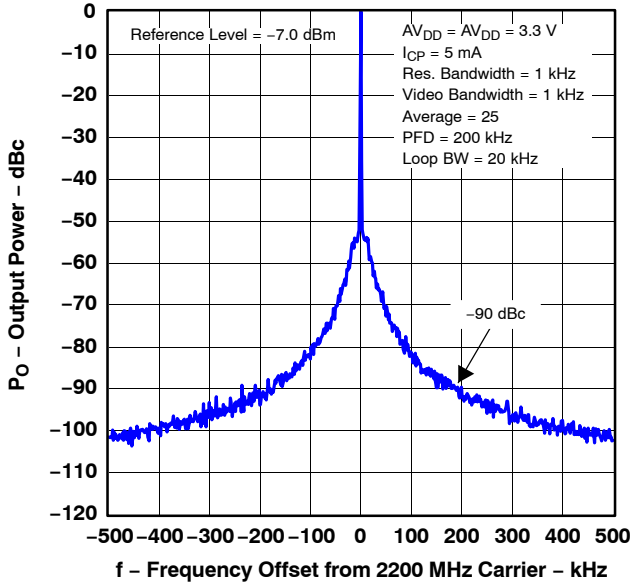

Figure 18. Reference Spurs
(RFOUT = 2200 MHz)

PHASE NOISE
vs
FREQUENCY

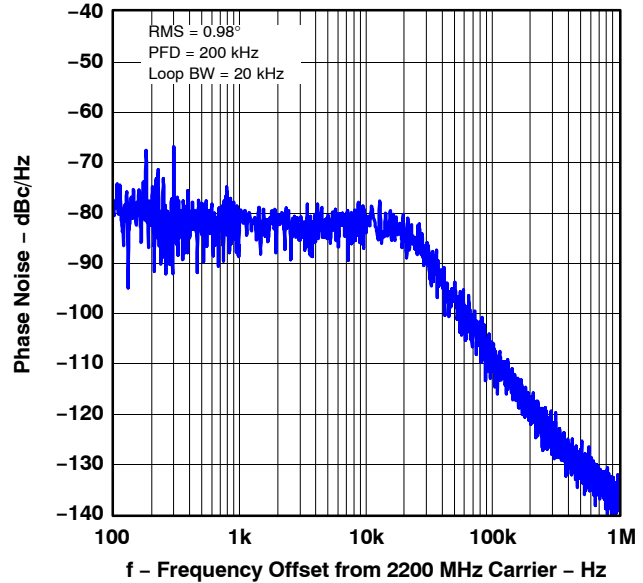

Figure 19. Integrated Phase Noise
(RFOUT = 2200 MHz)

PHASE NOISE
vs
FREE-AIR TEMPERATURE

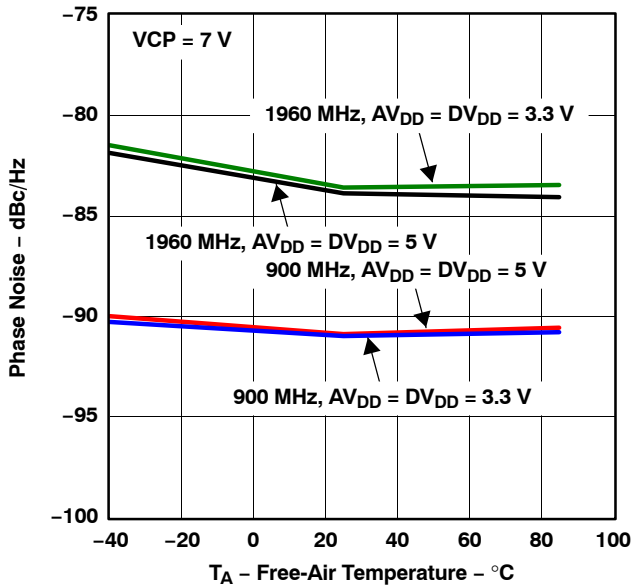

Figure 20.

REFERENCE SPUR LEVEL
vs
FREE-AIR TEMPERATURE

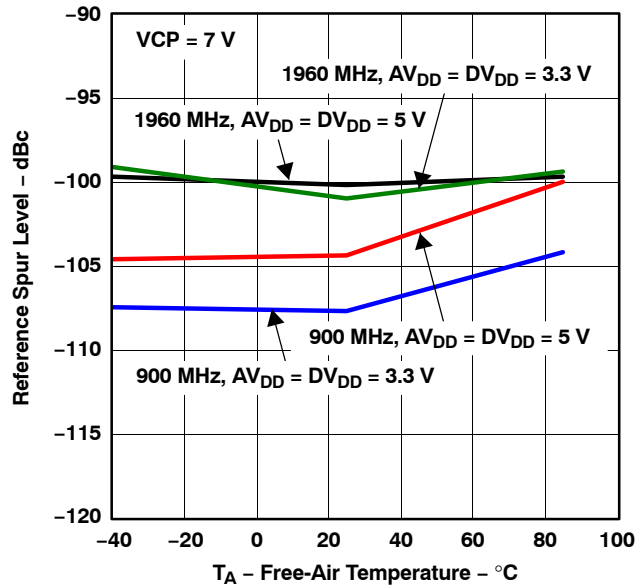

Figure 21.

TYPICAL CHARACTERISTICS

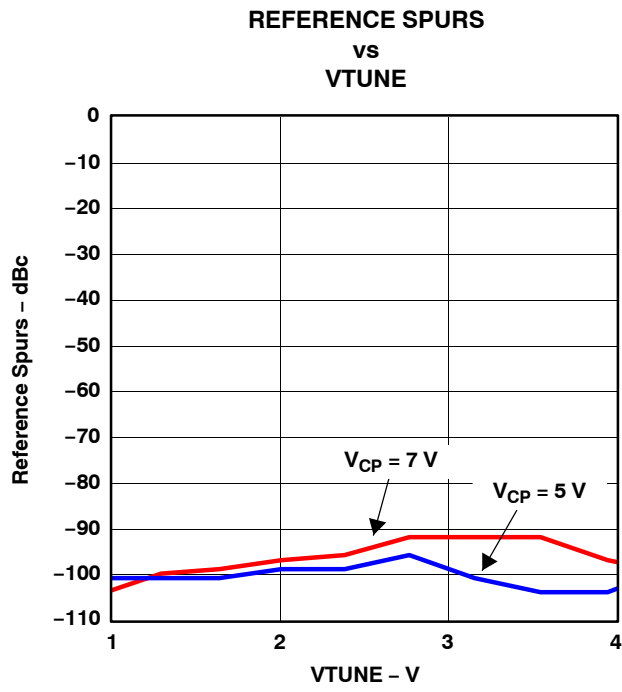

Figure 22.

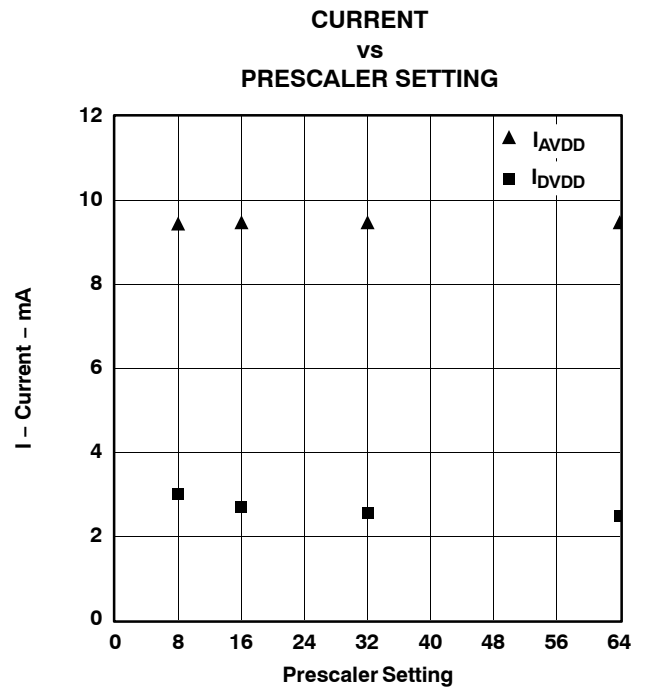

Figure 23.

Table 1. S_{11} Data for RFIN Buffer

FREQ (Hz)	MAG(S_{11})	PHASE(S_{11})
300M	849.388m	1.07722
344M	848.792m	1.02901
388M	848.317m	998.914m
432M	847.916m	981.324m
476M	847.565m	972.594m
520M	847.25m	970.294m
564M	846.962m	972.761m
608M	846.696m	978.834m
652M	846.448m	987.691m
696M	846.217m	998.737m
740M	846m	1.01154
784M	845.797m	1.02578
828M	845.605m	1.04122
872M	845.425m	1.05768
916M	845.255m	1.07502
960M	845.094m	1.09312
1.004G	844.943m	1.11191
1.048G	844.8m	1.13131
1.092G	844.664m	1.15127
1.136G	844.535m	1.17173
1.18G	844.413m	1.19267
1.224G	844.296m	1.21403
1.268G	844.185m	1.2358
1.312G	844.079m	1.25795
1.356G	843.978m	1.28045
1.4G	843.88m	1.30327
1.444G	843.787m	1.32641
1.488G	843.697m	1.34985
1.532G	843.61m	1.37355
1.576G	843.526m	1.39752
1.62G	843.444m	1.42174
1.664G	843.365m	1.44619
1.708G	843.288m	1.47086
1.752G	843.214m	1.49574
1.796G	843.14m	1.52082
1.84G	843.069m	1.54608
1.884G	842.999m	1.57152
1.928G	842.93m	1.59713
1.972G	842.862m	1.62291
2.016G	842.796m	1.64883
2.06G	842.73m	1.6749
2.104G	842.665m	1.70111
2.148G	842.601m	1.72744
2.192G	842.537m	1.7539
2.236G	842.474m	1.78048
2.28G	842.411m	1.80717
2.324G	842.349m	1.83397
2.368G	842.287m	1.86086
2.412G	842.225m	1.88786
2.456G	842.164m	1.91494
2.5G	842.103m	1.94211

FUNCTIONAL DESCRIPTION

REFIN Stage

This input typically comes from an external oscillator and is the reference used to synthesize the desired frequency on the output of the complete PLL. The equivalent schematic of this section is given in Figure 24. The output of this section goes to the R divider, so that the desired PFD frequency can be implemented.

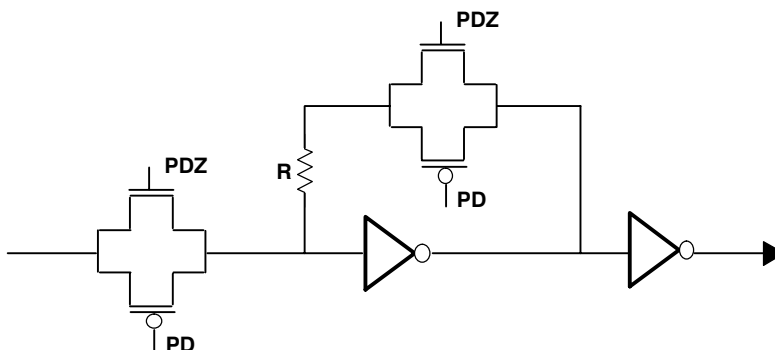

Figure 24. REFIN Stage

RFIN Stage

Figure 25 shows the input stage of the TRF3750. This is where the output of the external VCO is fed back to the synthesizer. The RFIN signal subsequently feeds the prescaler section.

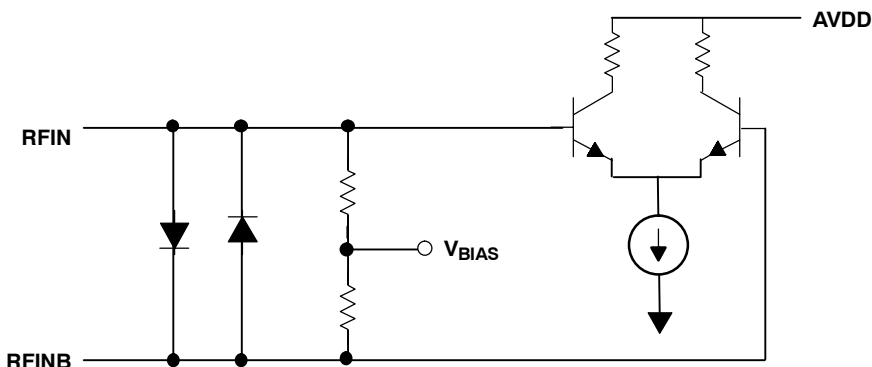

Figure 25. RFIN Stage

Prescaler Stage

This stage divides down the RFIN frequency before the A and B counters. This is a dual-modulus prescaler and the user can select any of the following settings: 8/9, 16/17, 32/33, and 64/65.

A and B Counter Stage

The TRF3750 includes a 6-bit A counter and a 13-bit B counter that operate on the output of the prescaler. The A counter can take values from 0 to 63, while the B counter can take values from 3 to 8191. Also, the value for the B counter has to be greater than or equal to the value for the A counter. These are CMOS devices, and can easily operate up to 200 MHz. The selection of the prescaler needs to be such that the resultant frequency does not exceed the rated 200-MHz threshold.

R Divider

The output of the REFIN stage is fed into the R divider stage. The 14-bit R divider allows the input reference frequency to be divided down to produce the reference clock to the phase frequency detector (PFD). Division ratios from 1 to 16,383 are allowed.

Phase Frequency Detector (PFD) and Charge Pump Stage

The outputs of the R divider and the N counter (please see pulse swallow section) are fed into the PFD stage, where the two signals are compared in frequency and phase. The TRF3750 features an anti-backlash pulse, whose width is controllable by the user, in order to optimize phase and spurious performance. The PFD feeds the charge pump, which is the final output of the TRF3750. The charge pump output pulses need to be fed into an external loop filter, which eventually produces the tuning voltage needed to control the external VCO to the desired frequency.

Pulse Swallow/Frequency Synthesis

The different stages of the TRF3750 enable the user to synthesize a large range of frequencies at the output of a complete PLL. For a given reference frequency (f_{REFIN}), the user's choice of the R divider yields the PFD frequency (f_{PFD}), which is the step by which the resultant output frequency can be incremented or decremented. The choice of prescaler, and A and B counters yields the output frequency at the external VCO (RFOUT) as shown below.

$$RFOUT = f_{PFD} \times N = (f_{REFIN} / R) \times (A + P \times B)$$

MUXOUT Stage

The TRF3750 features a multiplexer that allows programmable access to several signals. Table 5 and Table 6 show the truth tables. Some of the different signals available are detailed below.

Digital Lock Detect

This is an active high digital output that indicates when the device has achieved lock. The user can choose between two precision settings for the lock detection, through the reference counter latch. A 0 on the lock detect precision means that the digital lock detect output goes high only if three contiguous cycles of the PFD have an error of less than 15 ns. A 1 would require five contiguous cycles (a more stringent condition). Any error of greater than 25 ns, even on one cycle, would produce a 0 in the digital lock detect signal, indicating loss of lock.

Analog Lock Detect

Selecting the analog lock detect option at the output of the output multiplexer requires an external pull-up resistor ($\approx 10 \text{ k}\Omega$) to be placed on the output (MUXOUT, pin 14).

Fastlock Mode

The TRF3750 features two Fastlock Modes, which the user may select depending on the particular application. There are two separate charge pump current settings (1 and 2) that can be programmed, and the Fastlock Modes, when activated, enable the device to quickly switch from current setting 1 to current setting 2. The two Fastlock Modes (1 and 2) differ in the way the device reverts back to current setting 1. In normal (steady-state) operation, current setting 1 is used. For transient situations such as frequency jumps, current setting 2 can be used.

Fastlock Mode 1

As soon as Fastlock Mode 1 is entered, the charge pump current is switched to the preprogrammed setting 2 and stays there until the charge pump gain programming bit is set to 0 in the N counter latch. This way, the user has immediate software control of the transition between charge pump setting 1 and 2.

Fastlock Mode 2

As soon as Fastlock Mode 2 is entered, the charge pump current is switched to the preprogrammed setting 2 and stays there until the timer counter has expired. The timer counter is programmed by the user and counts how many PFD cycles the device spends in current setting 2 in Fastlock Mode 2. The number of timer cycles can be set in increments of four cycles in the range of 3 to 63. When the counter has expired, the device returns to normal operation (fastlock disabled and charge pump current setting 1). This way no extra programming is needed in order for the device to exit fastlock.

3-Wire Serial Programming

The TRF3750 features an industry-standard 3-wire serial interface that controls an internal 24-bit shift register. There are a total of 3 signals that need to be applied: the clock (CLK, pin 11), the serial data (DATA, pin 12) and the load enable (LE, pin13). The DATA (DB0–DB23) is loaded MSB first and is read on the rising edge of the CLK. The LE signal is asynchronous to the clock and at its rising edge the DATA gets loaded onto the

selected latch. The last two bits of the serial data (DB0 and DB1) are the bits that control one of the four available latches (R counter latch, N counter latch, function latch, and initialization latch). The truth table for selecting the appropriate latch is shown in Table 2.

Table 2. Latch Selection Truth Table

DB1 (C2)	DB0 (C1)	SELECTED DATA LATCH
0	0	R counter
0	1	N counter
1	0	Function
1	1	Initialization

Latch Description

Table 3. R Counter Latch

Reserved			Lock Detect Precision	Test Mode Bits		Anti Backlash Pulse Width		14-Bit Reference Counter, R														Control Bits	
DB23	DB22	DB21	DB20	DB19	DB18	DB17	DB16	DB15	DB14	DB13	DB12	DB11	DB10	DB9	DB8	DB7	DB6	DB5	DB4	DB3	DB2	DB1	DB0
X†	DLY	SYNC	LDP	T2	T1	ABP2	ABP1	R14	R13	R12	R11	R10	R9	R8	R7	R6	R5	R4	R3	R2	R1	C2(0)	C1(0)

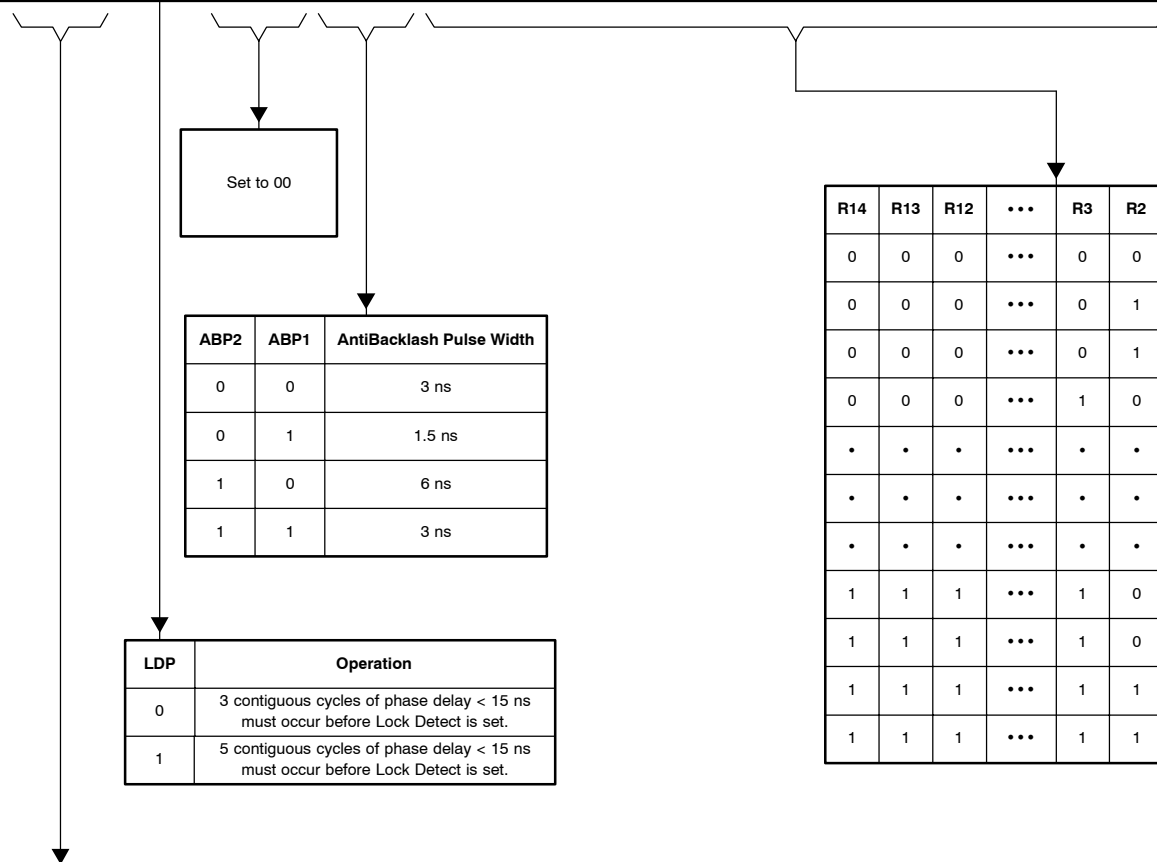

Set to 00

ABP2	ABP1	AntiBacklash Pulse Width
0	0	3 ns
0	1	1.5 ns
1	0	6 ns
1	1	3 ns

LDP	Operation
0	3 contiguous cycles of phase delay < 15 ns must occur before Lock Detect is set.
1	5 contiguous cycles of phase delay < 15 ns must occur before Lock Detect is set.

R14	R13	R12	...	R3	R2	R1	Divide Ratio
0	0	0	...	0	0	1	1
0	0	0	...	0	1	0	2
0	0	0	...	0	1	1	3
0	0	0	...	1	0	0	4
.
.
.
1	1	1	...	1	0	0	16380
1	1	1	...	1	0	1	16381
1	1	1	...	1	1	0	16382
1	1	1	...	1	1	1	16383

DLY	SYNC	Operation
0	0	Normal operation
0	1	Prescaler resynchronized with nondelayed form of RF input
1	0	Normal operation
1	1	Prescaler resynchronized with delayed form of RF input

† X = Don't Care

Latch Description (Continued)

Table 4. AB Counter Latch

Reserved		CP Gain	13-Bit B Counter													6-Bit A Counter						Control Bits	
DB23	DB22	DB21	DB20	DB19	DB18	DB17	DB16	DB15	DB14	DB13	DB12	DB11	DB10	DB9	DB8	DB7	DB6	DB5	DB4	DB3	DB2	DB1	DB0
X†	X†	G1	B13	B12	B11	B10	B9	B8	B7	B6	B5	B4	B3	B2	B1	A6	A5	A4	A3	A2	A1	C2(0)	C1(1)



B13	B12	B11	...	B3	B2	B1	B Counter Divide Ratio
0	0	0	...	0	0	0	N/A
0	0	0	...	0	0	1	N/A
0	0	0	...	0	1	0	N/A
0	0	0	...	0	1	1	3
0	0	0	...	1	0	0	4
.
.
.
1	1	1	...	0	0	0	8188
1	1	1	...	0	0	1	8189
1	1	1	...	1	1	0	8190
1	1	1	...	1	1	1	8191

A6	A5	...	A2	A1	A Counter
0	0	...	0	0	0
0	0	...	0	1	1
0	0	...	1	0	2
0	0	...	1	1	3
.
.
.
1	1	...	0	0	60
1	1	...	0	1	61
1	1	...	1	0	62
1	1	...	1	1	63

F4 (Function Latch D89) Fastlock Enable	CP Gain	Charge Pump Current Setting Operation
0	0	Current setting 1 is always used
0	1	Current setting 2 is always used
1	0	Current setting 1 used
1	1	Current setting 2 is used until fastlock mode exits (returns to current setting 1)

† X = Don't Care

Latch Description (Continued)

Table 5. Function Latch

Prescaler Value		Power Down 2	Current Setting 2			Current Setting 1			Timer Counter Control				Fastlock Mode	Fastlock Enable	CP Tri-State	Reser-ved	MUXOUT Control			Power Down 1	Counter Reset		Control Bits	
DB23	DB22	DB21	DB20	DB19	DB18	DB17	DB16	DB15	DB14	DB13	DB12	DB11	DB10	DB9	DB8	DB7	DB6	DB5	DB4	DB3	DB2	DB1	DB0	
P2	P1	PD2	CP16	CP15	CP14	CP13	CP12	CP11	TC4	TC3	TC2	TC1	F5	F4	F3	X†	M3	M2	M1	PD1	F1	C2(1)	C1(0)	

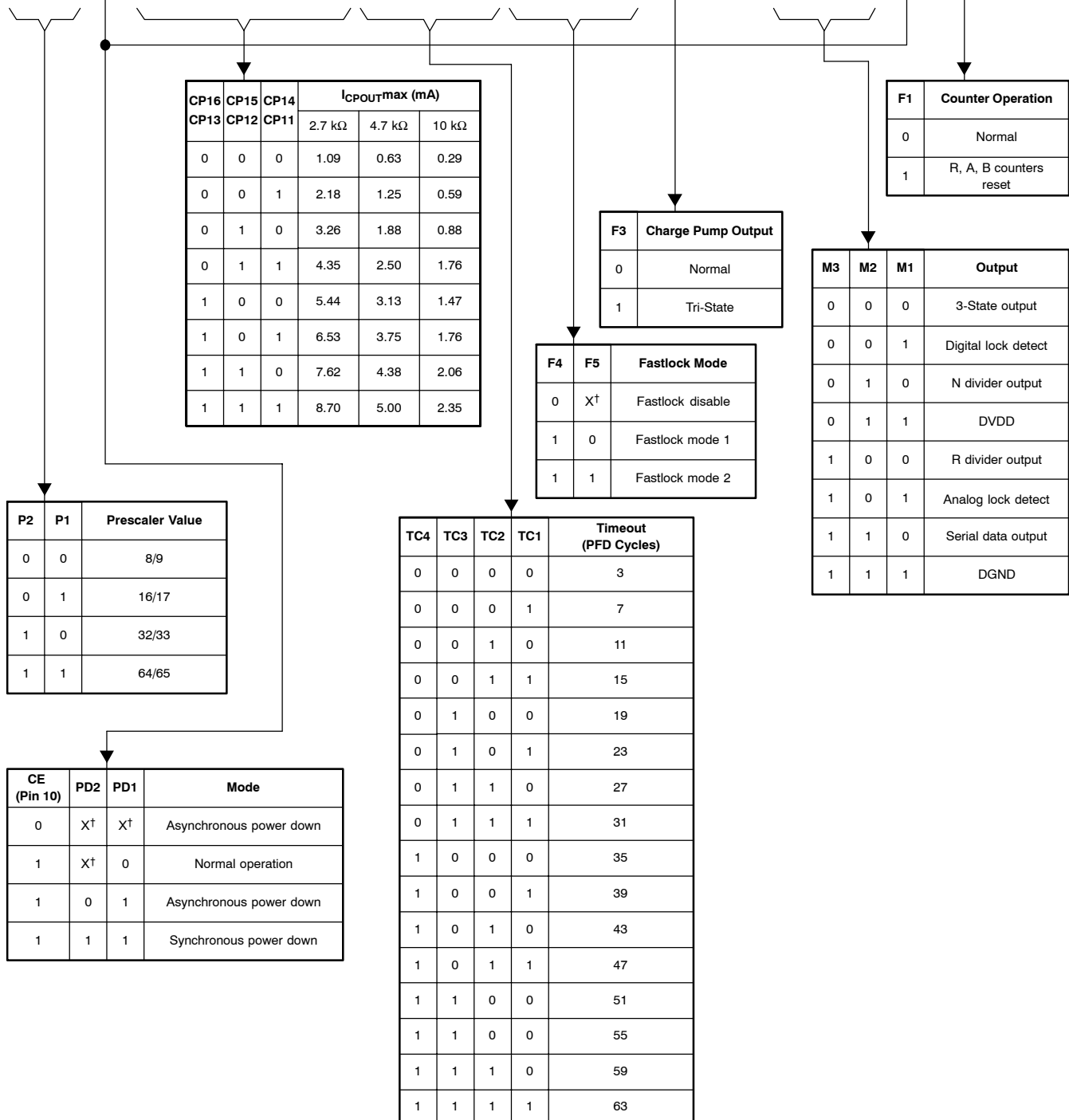

CP16 CP13	CP15 CP12	CP14 CP11	$I_{CPoutmax}$ (mA)		
			2.7 k Ω	4.7 k Ω	10 k Ω
0	0	0	1.09	0.63	0.29
0	0	1	2.18	1.25	0.59
0	1	0	3.26	1.88	0.88
0	1	1	4.35	2.50	1.76
1	0	0	5.44	3.13	1.47
1	0	1	6.53	3.75	1.76
1	1	0	7.62	4.38	2.06
1	1	1	8.70	5.00	2.35

P2	P1	Prescaler Value
0	0	8/9
0	1	16/17
1	0	32/33
1	1	64/65

CE (Pin 10)	PD2	PD1	Mode
0	X†	X†	Asynchronous power down
1	X†	0	Normal operation
1	0	1	Asynchronous power down
1	1	1	Synchronous power down

TC4	TC3	TC2	TC1	Timeout (PFD Cycles)
0	0	0	0	3
0	0	0	1	7
0	0	1	0	11
0	0	1	1	15
0	1	0	0	19
0	1	0	1	23
0	1	1	0	27
0	1	1	1	31
1	0	0	0	35
1	0	0	1	39
1	0	1	0	43
1	0	1	1	47
1	1	0	0	51
1	1	0	0	55
1	1	1	0	59
1	1	1	1	63

F3	Charge Pump Output
0	Normal
1	Tri-State

F4	F5	Fastlock Mode
0	X†	Fastlock disable
1	0	Fastlock mode 1
1	1	Fastlock mode 2

F1	Counter Operation
0	Normal
1	R, A, B counters reset

M3	M2	M1	Output
0	0	0	3-State output
0	0	1	Digital lock detect
0	1	0	N divider output
0	1	1	DVDD
1	0	0	R divider output
1	0	1	Analog lock detect
1	1	0	Serial data output
1	1	1	DGND

† X = Don't Care

Latch Description (Continued)

Table 6. Initialization Latch

Prescaler Value		Power Down 2		Current Setting 2			Current Setting 1				Timer Counter Control				Fastlock Mode	Fastlock Enable	CP 3-State	Reserved	MUXOUT Control			Power Down 1	Counter Reset	Control Bits	
DB23	DB22	DB21	DB20	DB19	DB18	DB17	DB16	DB15	DB14	DB13	DB12	DB11	DB10	DB9	DB8	DB7	DB6	DB5	DB4	DB3	DB2	DB1	DB0		
P2	P1	PD2	CP16	CP15	CP14	CP13	CP12	CP11	TC4	TC3	TC2	TC1	F5	F4	F3	X†	M3	M2	M1	PD1	F1	C2(1)	C1(1)		

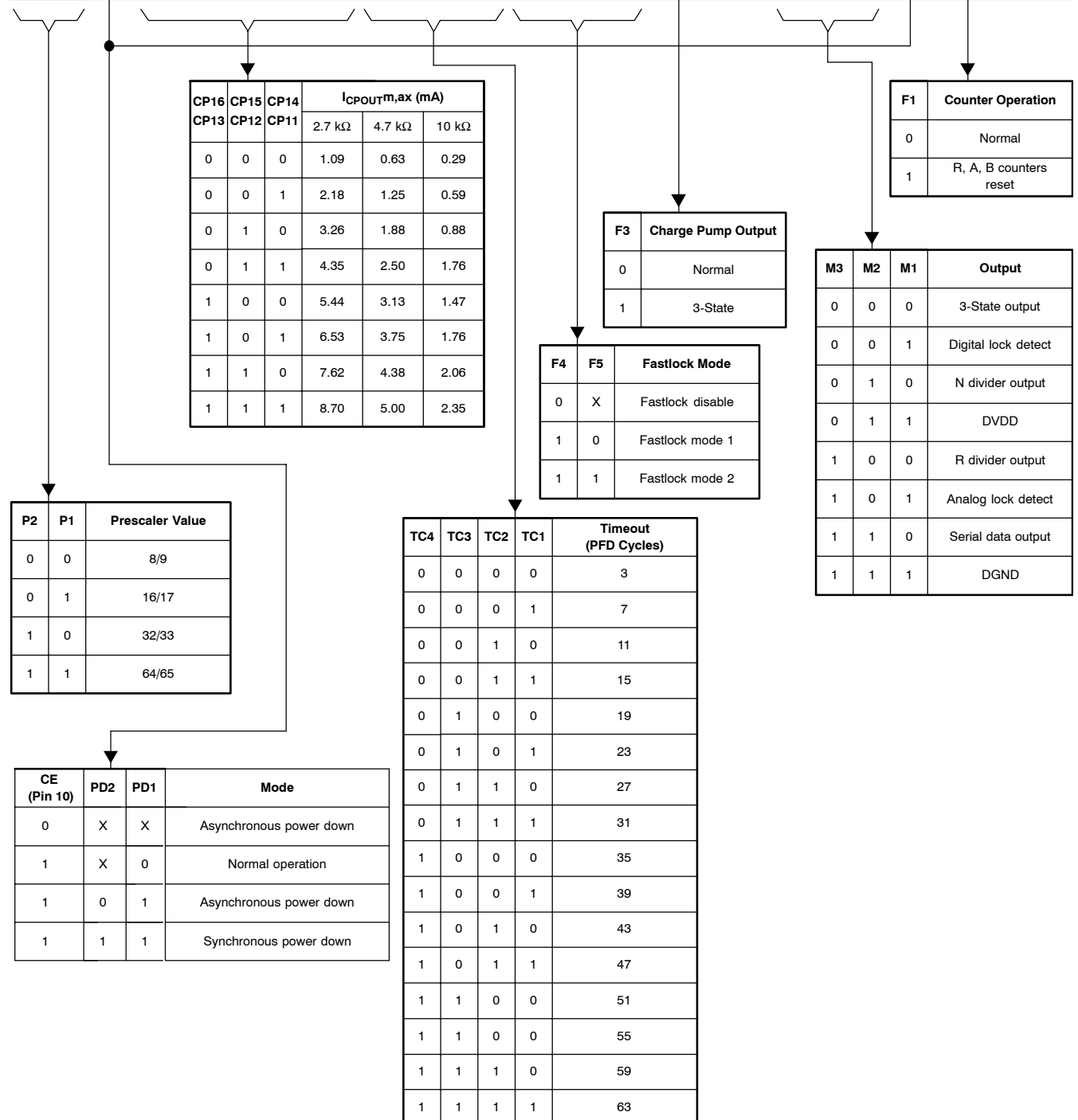

† X = Don't Care

R Counter Latch

By selecting (0,0) for the control bits DB0 and DB1, the R counter latch is selected. Table 7 shows the setup of the R counter latch.

Table 7. R Counter Latch

Reserved	DLY	SYNC	Lock Detect Precision	Test Mode Bits		Anti Backlash Width		14-Bit Reference Counter; R														Control Bits	
				DB19	DB18	DB17	DB16	DB15	DB14	DB13	DB12	DB11	DB10	DB9	DB8	DB7	DB6	DB5	DB4	DB3	DB2	DB1	DB0
X	DLY	SYNC	LDP	T2	T1	ABP2	ABP1	R14	R13	R12	R11	R10	R9	R8	R7	R6	R5	R4	R3	R2	R1	C2(0)	C1(0)

R Value

This latch is used primarily to select the R divider for the input reference signal (REFIN). DB2 through DB15 are used to select the chosen value for the 14-bit counter. DB2 is the LSB and DB15 the MSB.

Anti-backlash Pulse

DB16 and DB17 can be used to select the width of the anti-backlash pulse in the PFD. In any PFD implementation, there is an inherent risk of *backlash*, a phenomenon that can occur when the device is almost in lock. In order to ensure that there are always pulses coming out of the charge pump and that therefore the VCO cannot drift out of lock, the TRF3750 employs an anti-backlash pulse. The user can select the width of the anti-backlash pulse; the values allowed are 1.5 ns, 3 ns, and 6 ns.

Lock Detect Precision

Setting DB20 of the R counter latch to 0 results in a precision of three cycles for the lock detect, while setting it to 1 results in a precision of five cycles.

Sync / Delay

DB21–22 control the sync/delay operation of the device. If DB21 is 0, then the device is in normal operation. Assuming DB21 is set to 1, setting DB22 to 0 utilizes a non-delayed form of the RF signal for the resynchronization of the prescaler output, whereas setting DB22 to 1 utilizes a delayed form.

Reserved Bits

Bits DB18, DB19 and DB23 of the R counter latch are reserved. It is recommended to keep those bits 0 for normal operation.

N Counter Latch

Setting (DB1, DB0) = (0,1) for the latch control bits selects the N counter latch. Table 8 shows the setup of the N counter latch.

Table 8. N Counter Latch

Reserved		CP Gain	13-Bit B Counter													6-Bit B Counter					Control Bits 1		
DB23	DB22	DB21	DB20	DB19	DB18	DB17	DB16	DB15	DB14	DB13	DB12	DB11	DB10	DB9	DB8	DB7	DB6	DB5	DB4	DB3	DB2	DB1	DB0
X	X	G1	B13	B12	B11	D10	B9	B8	B7	B6	B5	B4	B3	B2	B1	A6	A5	A4	A3	A2	A1	C2(0)	C1(0)

A Counter

The 6 bits DB2–DB7 control the value of the A counter. The valid range is from 0 to 63. For example, programming (DB7, DB6, DB5, DB4, DB3, DB2) = (0,0,0,0,1,0) results in a value of 2 for the A counter.

B Counter

The 13 bits DB8–DB20 of the N counter latch control the value of the B counter. The valid range is from 3 to 8191. For example, (DB20, DB19, ..., DB10, DB9, DB8) = (0, 0, 0, 0, 0, 0, 0, 0, 0, 0, 1, 0, 0) results in a value of 4 for the B counter.

Charge Pump Gain

DB21 of the N counter latch determines when the TRF3750 enters Fastlock Mode. When this bit is 1, the device switches into fastlock and when this bit is 0, the device exits fastlock (fastlock mode 1).

Reserved Bits

Bits DB22–DB23 of the N counter latch are reserved and can be treated as don't cares by the user.

Function Latch

Table 9 depicts the function latch. By selecting (0,1) for the control bits DB0 and DB1, the function latch is selected.

Table 9. Function Latch

Prescaler Value		Power Down 2	Current Setting 2					Current Setting 1					Timer Counter Control				Fasklock Mode	Fasklock Enable	CP Tri-State	Reserved	MUXOUT Control			Power Down 1	Counter Reset	Control Bits	
DB23	DB22	DB21	DB20	DB19	DB18	DB17	DB16	DB15	DB14	DB13	DB12	DB11	DB10	DB9	DB8	DB7	DB6	DB5	DB4	DB3	DB2	DB1	DB0				
P2	P1	PD2	CPI6	CPI5	CPI4	CPI3	CPI2	CPI1	TC4	TC3	TC2	TC1	F5	F4	F3	X	M3	M2	M1	PD1	F1	C2(1)	C1(0)				

Counter Reset Bit

When this bit is set to 1, all the counters in the PLL are reset. This includes the R, A, and B counters. In a typical application, this bit should be set to 0.

Power Down

The complete power down functionality of the TRF3750 is controlled in software by the two bits DB3 and DB21 in the function latch and in hardware by the external pin CE (pin 10). When the TRF3750 enters the power down state, the power consumption is lowered, the charge pump is 3-stated, but the registers are still operational enabling programming of the device. The hardware power down (CE set to 0) is immediate and asynchronous. Assuming that CE is set to 1, the two bits can select between the software power down options available. Setting DB3 to 0 enables normal operation of the PLL. When (DB21, DB3) = (0,1), then the asynchronous power down is selected, which means that the device powers down as soon as the programming is read. When (DB21, DB3) = (1,1), then the synchronous power down is enabled. In this mode, the device enters power down on the next cycle of the charge pump. This is a more controlled power down, as it avoids potential transients or erroneous output frequencies.

MUXOUT

Bits DB4, DB5, and DB6 determine what signal appears at the output of the internal multiplexer, as described in Table 5. For example, the most widely used output signal on this pin would be the digital lock detect signal, which goes high when lock has been achieved. In order to program this mode, the user has to set (DB4, DB5, DB6) = (1,0,0).

Charge Pump 3-state

DB8 of the function latch can set the output of the charge pump in a 3-state mode, if set to 1. Normal operation of the device is attained when this bit is 0.

Fastlock Enable and Mode

Setting DB9 of the function latch to 1 enables the Fastlock Mode, whereas setting it to 0 deactivates this feature altogether. Assuming that DB9 is 1, DB10 selects between the two possible Fastlock Modes: Fastlock Mode 1 is selected when DB10 is 0, whereas Fastlock Mode 2 is selected when DB10 is 1. The device actually enters fastlock when the charge pump gain bit in the N counter latch (DB21) is set to 1. Once in Fastlock Mode 1, the device switches back when DB21 of the N counter latch is set to 0. Conversely, once in Fastlock Mode 2, the device switches back after the timeout condition has been reached, at which point DB21 of the N counter latch is automatically set to 0.

Timer Counter Control

DB11–DB14 of the function latch control the timer counter, in case the Fastlock Mode 2 was selected. These four bits give the user the capability to program the number of PFD cycles that elapse before the device exits the Fastlock Mode. Valid values for this are 3 to 63, in steps of 4 cycles. For example, programming (DB14, DB13, DB12, DB11) = (0,0,1,0) results in 11 cycles before the Fastlock Mode times out.

Current Settings 1 and 2

DB15–DB17 control the maximum charge pump current setting 1, while DB18–20 control current setting 2. The actual value of the maximum charge pump current will be dictated by the resistor placed outside on R_{SET} (pin1).

Prescaler Selection

DB22–DB23 of the function latch controls the prescaler value for the device. There are four possible settings (9/9, 16/17, 32/33, 64/65). For example, setting (DB23, DB22) = (1,0) results in a prescaler choice of 32/33.

Initialization Latch / Programming After Power Up

Setting (DB1, DB0) = (1,1) selects the initialization latch. The make-up and programming of the initialization latch is identical to that of the function latch. The difference here is that this latch can be used in order to program the device at power up. When the initialization latch is programmed, an internal reset occurs at all the counters (R, A, B) who become ready to get loaded, assuring that the next time data is loaded for the A and B counters the device begins counting efficiently. Subsequent programming of the A and B counters will not, however, cause this internal pulse to recur. This pulse is also used to gate the synchronous power down when that mode is engaged. As soon as the device exits power down, the counting resumes promptly.

Alternate Ways of Programming After Power Up

In addition to the method of using the initialization latch described above, the user can also utilize the CE pin to achieve initialization. Since the CE does not halt the operation of the serial port, the user can preprogram the counters and as soon as the device is enabled, the counters operate and the device reaches a steady-state and functions normally.

A third option in power up is the counter reset method. The function latch is programmed with the desired data, and in addition DB2 (the counter reset bit) is set to 1. The R counter latch is programmed next, followed by the N counter latch. Finally, the function latch is programmed again, but this time with a 0 in the bit DB2, disabling the counter reset. The charge pump is 3-stated during the reset, but the synchronous power down is not triggered.

Prescaler Resynchronization

DB22 and DB21 of the R counter latch are used to control the delay (DLY) and resynchronization (SYNC) functions of the device. If SYNC is set to 1, then the output of the prescaler is resynchronized with the RF input. In addition, if DLY is also 1, the output of the prescaler gets resynchronized with a delayed form of the RF input signal. In either case, taking the SYNC to 0 reverts the device to normal operation.

The use of the SYNC and DLY functionality can improve the device's phase noise performance by a few dBs. It is, however, susceptible to potential malfunction, in case the chosen edge of the RF input coincides with the prescaler. This phenomenon may be mitigated by using the DLY function, but is nonetheless unpredictable and care should be applied, as fluctuations in temperature, supply and frequency can alter the point at which the feature fails to operate. The normal operation of the device calls for both DLY and SYNC to be set to 0, which is the way the TRF3750 has been characterized.

APPLICATION INFORMATION

SYNTHESIZING A SELECTED FREQUENCY

The TRF3750 is an integer-N PLL synthesizer, and because of its flexibility (14-bit R, 6-bit A, 13-bit B counter, and dual modulus prescaler), is ideal for synthesizing virtually any desired frequency. Let us assume that we need to synthesize a 900-MHz local oscillator, with spacing capability (minimum frequency increment) of 200 kHz, as in a typical GSM application. The choice of the external reference oscillator to be used is beyond the scope of this section, but assuming that a 10-MHz reference is selected, we calculate the settings that yield the desired output frequency and channel spacing. There is usually more than one solution to a specific set of conditions, so below is one way of achieving the desired result.

First, select the appropriate R counter value. Since a channel spacing of 200 kHz is desired, the PFD can also be set to 200 kHz. Calculate the R value through $R = \text{REFIN}/\text{PFD} = 10 \text{ MHz} / 200 \text{ kHz} = 50$. Assume a prescaler value of 8/9 is selected. This is a valid choice, since the prescaler output will be well within the 200-MHz limit ($900 \text{ MHz} / 8 = 112.5 \text{ MHz}$). Select the appropriate A and B counter values. We know that $\text{RFOUT} = f_{\text{PFD}} \times N = (f_{\text{REFIN}} / R) \times (A + P \times B)$. Therefore, we need to solve the following equation:

$$900 \text{ MHz} = 200 \text{ kHz} \times (A + 8 \times B)$$

Clearly there are many solutions to this single equation with two unknowns; there are some basic constraints on the solution, since $3 \leq B \leq 8191$, and also $B \geq A$. So, if we pick $A = 4$, solving the equation yields $B = 562$. Thus, one complete solution would be to choose: $R = 50$, $A = 4$, $B = 562$, and $P = 8/9$, resulting in the desired $N = 4500$.

The GUI software accompanying the evaluation board of the TRF3750 includes an easy Parameter Selection Assistant that can directly propose appropriate values for all the counters given the user's requirements. In addition, the software can configure all the possible settings of the TRF3750 and can output the data stream required, so that the user has a reference when programming the serial port.

To complete the example, the serial port has to be programmed in order for the correct frequency to appear at the output of the complete PLL. Assuming that the user wanted to program the same modes as used in the *RF Performance Specifications* section, a possible sequence of serial data going into the device could be the one listed below for the three different latches (note that the initialization latch is not used in this example):

Table 10. R Counter Latch Programming Example

DB 23	DB 22	DB 21	DB 20	DB 19	DB 18	DB 17	DB 16	DB 15	DB 14	DB 13	DB 12	DB 11	DB 10	DB9	DB8	DB7	DB6	DB5	DB4	DB3	DB2	DB1	DB0
0	0	0	1	0	0	0	1	0	0	0	0	0	0	0	0	1	1	0	0	1	0	0	0

Table 11. N Counter Latch Programming Example

DB 23	DB 22	DB 21	DB 20	DB 19	DB 18	DB 17	DB 16	DB 15	DB 14	DB 13	DB 12	DB 11	DB 10	DB9	DB8	DB7	DB6	DB5	DB4	DB3	DB2	DB1	DB0
0	0	0	0	0	0	1	0	0	0	1	1	0	0	1	0	0	0	0	1	0	0	0	1

Table 12. Function Latch Programming Example

DB 23	DB 22	DB 21	DB 20	DB 19	DB 18	DB 17	DB 16	DB 15	DB 14	DB 13	DB 12	DB 11	DB 10	DB9	DB8	DB7	DB6	DB5	DB4	DB3	DB2	DB1	DB0
0	0	0	1	1	1	1	1	1	0	0	0	1	0	0	0	1	0	0	1	0	0	1	0

Building a Complete PLL Using the TRF3750

This application of the TRF3750 is just one of many possible ways in which a wireless infrastructure transmitter LO can be implemented for GSM applications and beyond.

Supplies/Decoupling

Appropriate decoupling is important in ensuring optimum noise performance of the device. Ideally, the AVDD and DVDD supplies should be separated through a ferrite and be at the same potential. A larger capacitor, in the order of a 10 μ F, should be placed in the supply chain, followed by a couple of small value decoupling capacitors very close to the device's supply pins. Typical values are 0.1 μ F and 10 pF. The decoupling capacitors should not be shared and should be chosen to have low ESR. The V_{CP} supply needs to be at least 1 V greater than the AVDD and DVDD supplies and similar decoupling should be applied.

Reference

A large range of frequencies can be used for the reference input. In this example, an external TCXO of 10 MHz is used to provide the stable reference frequency for the REFIN pin of the device. The quality of the reference oscillator is important, and its phase noise needs to be significantly lower than what is expected of the entire loop as it does not get attenuated in the loop. Typically, such devices do not require 50- Ω terminations and can be taken into the PLL ac coupled. The TRF3750 has a large range of power levels that it can accept at the REFIN input; however stronger signals result typically in better phase noise performance. Values of +5 dBms (referred to 50 Ω) should yield excellent performance. The TRF3750 is compatible with most commercially available oscillators.

VCO Selection

Plenty of VCOs exist in the market that can cover the frequency range of all wireless applications today. One clear advantage of the TRF3750 is that it features an extended charge pump supply, allowing interface to VCOs with larger tuning ranges. V_{CP} can be as high as 8 V, which implies that VCOs with tuning voltage ranges of 7 V can easily be accommodated. In closing the loop with the VCO, it is important to ensure that proper termination is observed, especially in the higher range of frequency operation. A standard resistive splitter implementation works well, where each of the three Rs in the classic T connection assume the value of 16.6 Ω . In other cases where impedance matching is less critical than getting maximum power out of the whole PLL loop, the user may decide to leave the resistors out and just tap off a trace from the VCO output and feed it back to the synthesizer. Additionally, a small series resistor can be placed in the feedback path towards the TRF3750 so as to reduce the relative power delivered to the PLL versus that available for the transmitter. The VCO's supply should also be decoupled as recommended by the manufacturer.

Loop Filter Design

Numerous methodologies and design techniques exist for designing optimized loop filters for particular applications. The loop filter design can affect the stability of the loop, the lock time, the bandwidth, the extra attenuation on the reference spurs, etc. The role of the loop filter is to integrate and lowpass the pulses of the charge pump and eventually yield an output tuning voltage that drives the VCO. Several filter topologies can be implemented, including both passive and active. In this section, we use a third-order passive filter. For this example, we assume several design parameters. First, the VCO's manufacturer should specify the device's K_V , which is given in MHz/V. Here we assume a value of 12 MHz/V, meaning that in the linear region, changing the tuning voltage of the VCO by 1 V induces a change of the output frequency of about 12 MHz. We already know that $N = 4500$ and that our $f_{PFD} = 200$ kHz. We also further assume that current setting 1 will be used and be set to maximum current of 5 mA. In addition, we need to determine the bandwidth of the loop filter. This is a critical consideration as it affects (among other things) the lock time of the system. Assuming an approximate bandwidth of around 20 kHz is needed, and that for stability we desire a phase margin of about 45 degrees, the following values for the components of the loop filter can be derived. These values, along with the rest of the example circuitry, are shown in Figure 26. It is important to note here that there are almost infinite solutions to the problem of designing the loop filter and the designer is called to make tradeoff decisions for each application.

Application Example for Direct IQ Upconversion Wireless Infrastructure Transmitter (Continued)

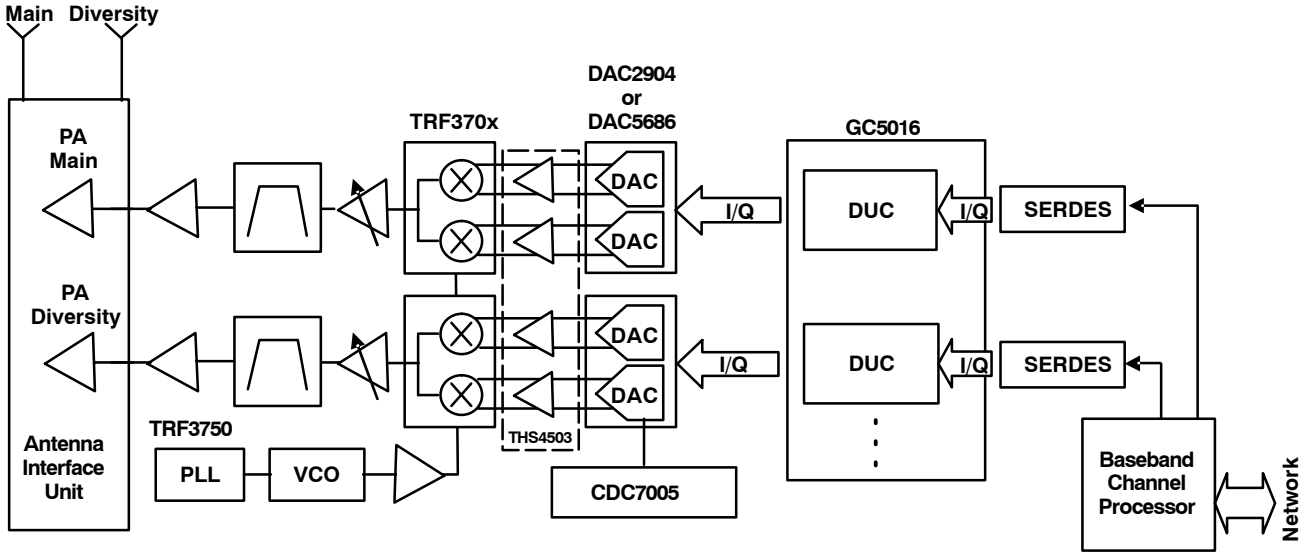
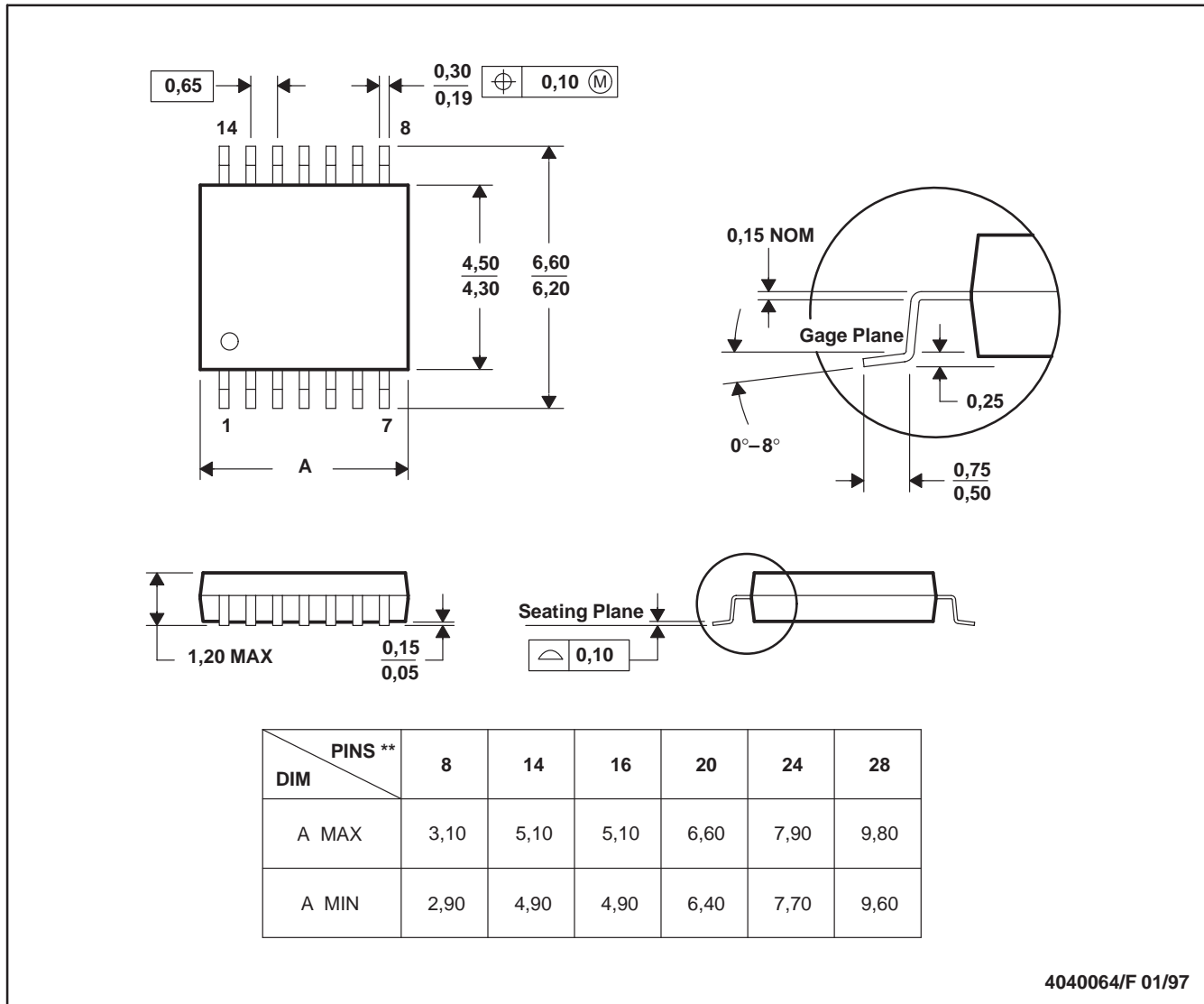

Figure 27. Texas Instruments' Proposed Direct Upconversion Wireless Infrastructure Transmitter Architecture

PW (R-PDSO-G**)

PLASTIC SMALL-OUTLINE PACKAGE

14 PINS SHOWN



4040064/F 01/97

- NOTES: A. All linear dimensions are in millimeters.
 B. This drawing is subject to change without notice.
 C. Body dimensions do not include mold flash or protrusion not to exceed 0,15.
 D. Falls within JEDEC MO-153

THERMAL INFORMATION

This package incorporates an exposed thermal pad that is designed to be attached directly to an external heatsink. The thermal pad must be soldered directly to the printed circuit board (PCB), the PCB can be used as a heatsink. In addition, through the use of thermal vias, the thermal pad can be attached directly to a ground plane or special heatsink structure designed into the PCB. This design optimizes the heat transfer from the integrated circuit (IC).

For information on the Quad Flatpack No-Lead (QFN) package and its advantages, refer to Application Report, Quad Flatpack No-Lead Logic Packages, Texas Instruments Literature No. SCBA017. This document is available at www.ti.com.

The exposed thermal pad dimensions for this package are shown in the following illustration.

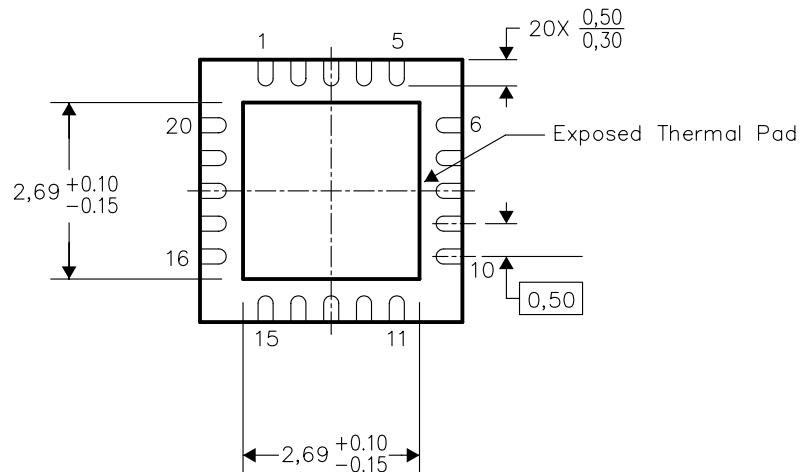

Bottom View

NOTE: All linear dimensions are in millimeters

Exposed Thermal Pad Dimensions

PACKAGING INFORMATION

Orderable Device	Status ⁽¹⁾	Package Type	Package Drawing	Pins	Package Qty	Eco Plan ⁽²⁾	Lead/Ball Finish	MSL Peak Temp ⁽³⁾
TRF3750IPW	ACTIVE	TSSOP	PW	16	90	None	CU NIPDAU	Level-1-220C-UNLIM
TRF3750IPWR	ACTIVE	TSSOP	PW	16	2000	None	CU NIPDAU	Level-1-220C-UNLIM
TRF3750IRGP	ACTIVE	QFN	RGP	20	91	Green (RoHS & no Sb/Br)	CU NIPDAU	Level-2-260C-1 YEAR
TRF3750IRGPR	ACTIVE	QFN	RGP	20	1000	Green (RoHS & no Sb/Br)	CU NIPDAU	Level-2-260C-1 YEAR
TRF3750IRGPRG4	ACTIVE	QFN	RGP	20	1000	None	Call TI	Call TI

⁽¹⁾ The marketing status values are defined as follows:

ACTIVE: Product device recommended for new designs.

LIFEBUY: TI has announced that the device will be discontinued, and a lifetime-buy period is in effect.

NRND: Not recommended for new designs. Device is in production to support existing customers, but TI does not recommend using this part in a new design.

PREVIEW: Device has been announced but is not in production. Samples may or may not be available.

OBSOLETE: TI has discontinued the production of the device.

⁽²⁾ Eco Plan - May not be currently available - please check <http://www.ti.com/productcontent> for the latest availability information and additional product content details.

None: Not yet available Lead (Pb-Free).

Pb-Free (RoHS): TI's terms "Lead-Free" or "Pb-Free" mean semiconductor products that are compatible with the current RoHS requirements for all 6 substances, including the requirement that lead not exceed 0.1% by weight in homogeneous materials. Where designed to be soldered at high temperatures, TI Pb-Free products are suitable for use in specified lead-free processes.

Green (RoHS & no Sb/Br): TI defines "Green" to mean "Pb-Free" and in addition, uses package materials that do not contain halogens, including bromine (Br) or antimony (Sb) above 0.1% of total product weight.

⁽³⁾ MSL, Peak Temp. -- The Moisture Sensitivity Level rating according to the JEDEC industry standard classifications, and peak solder temperature.

Important Information and Disclaimer: The information provided on this page represents TI's knowledge and belief as of the date that it is provided. TI bases its knowledge and belief on information provided by third parties, and makes no representation or warranty as to the accuracy of such information. Efforts are underway to better integrate information from third parties. TI has taken and continues to take reasonable steps to provide representative and accurate information but may not have conducted destructive testing or chemical analysis on incoming materials and chemicals. TI and TI suppliers consider certain information to be proprietary, and thus CAS numbers and other limited information may not be available for release.

In no event shall TI's liability arising out of such information exceed the total purchase price of the TI part(s) at issue in this document sold by TI to Customer on an annual basis.

DRU (S-PDSO-N8)

PLASTIC SMALL OUTLINE

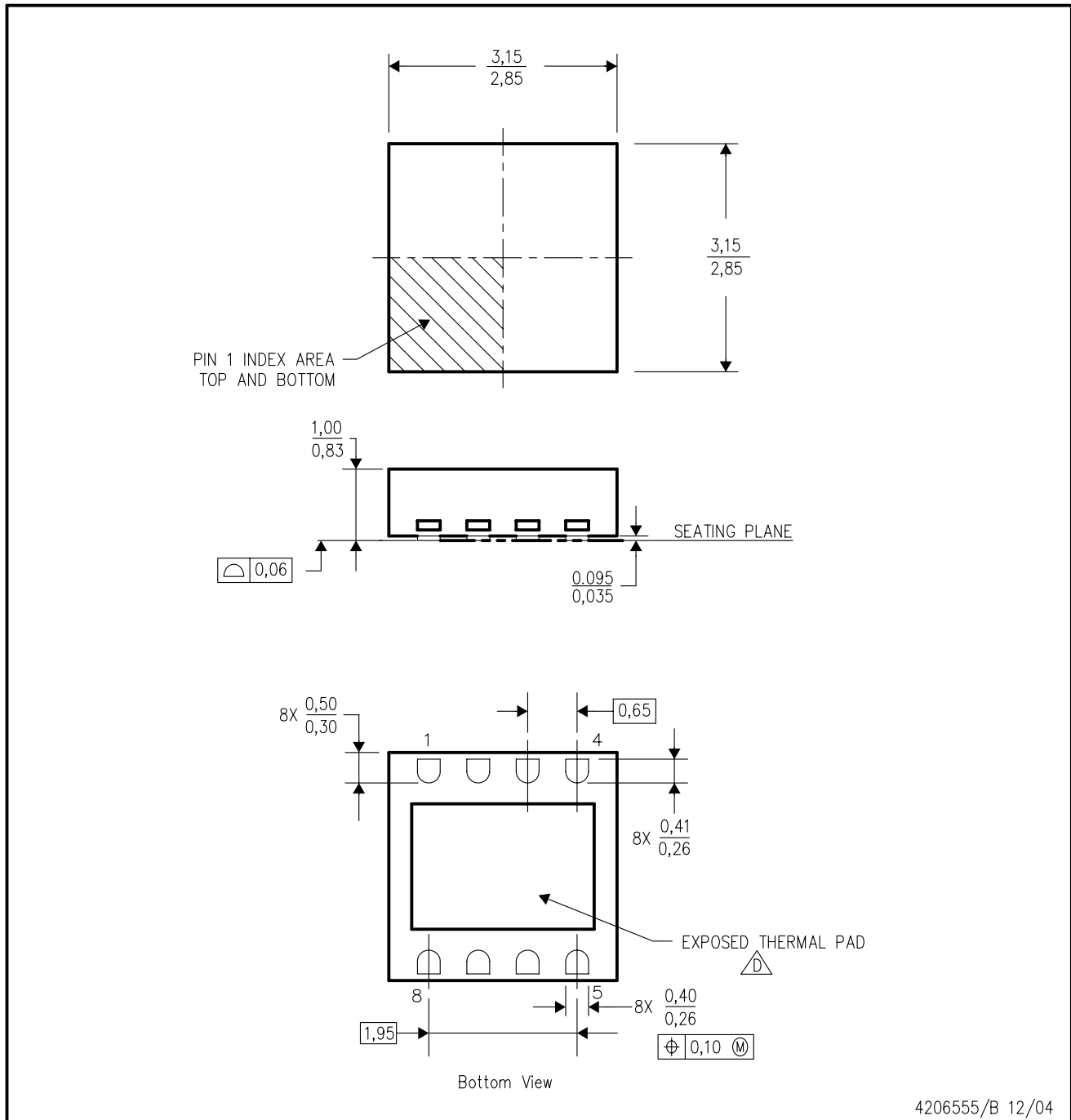

- NOTES:
- A. All linear dimensions are in millimeters. Dimensioning and tolerancing per ASME Y14.5M-1994.
 - B. This drawing is subject to change without notice.
 - C. Small Outline No-Lead (SON) package configuration.
 -  D. The package thermal pad must be soldered to the board for thermal and mechanical performance. See the Product Data Sheet for details regarding the exposed thermal pad dimensions.

PW (R-PDSO-G**)

PLASTIC SMALL-OUTLINE PACKAGE

14 PINS SHOWN

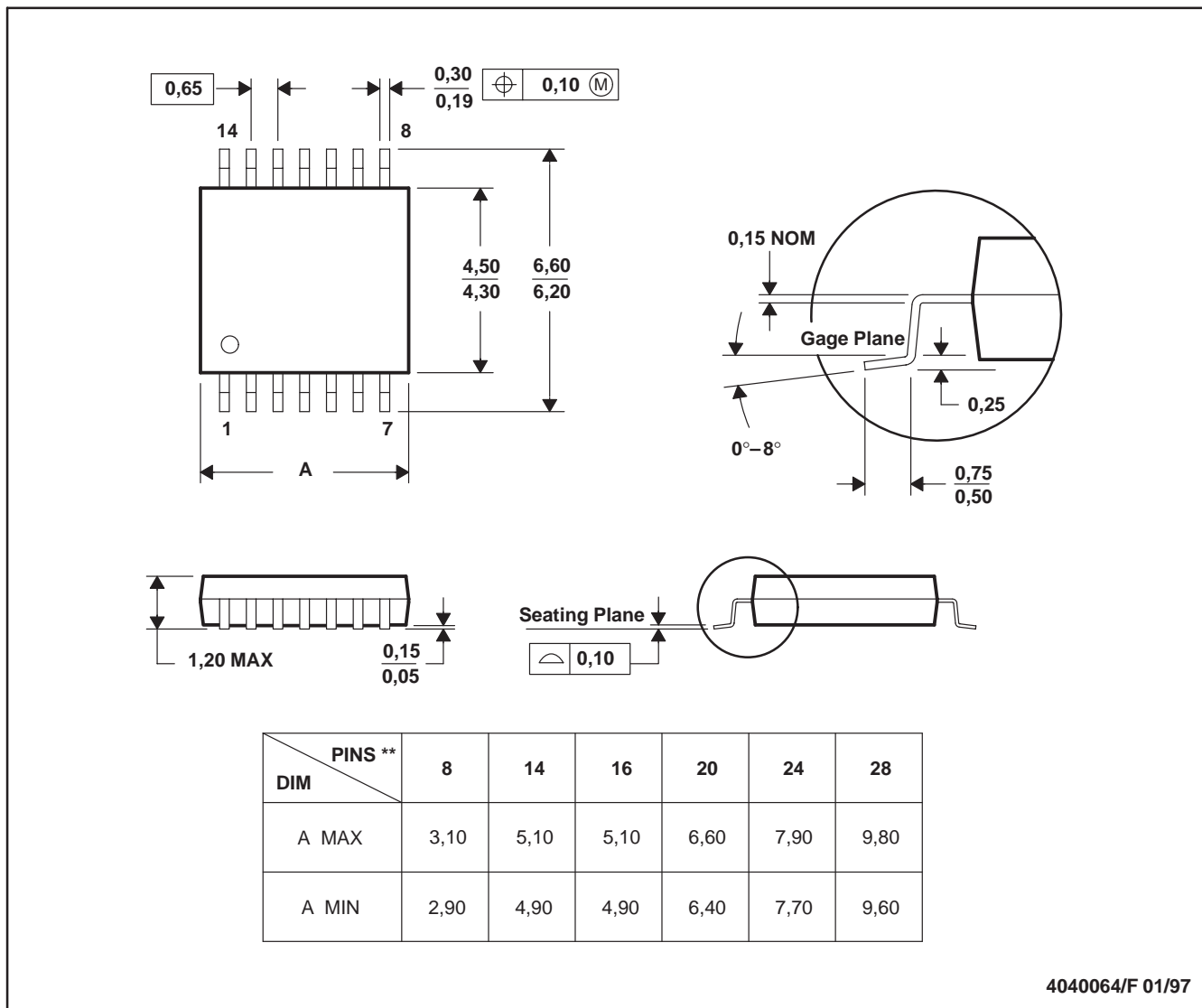

4040064/F 01/97

- NOTES: A. All linear dimensions are in millimeters.
 B. This drawing is subject to change without notice.
 C. Body dimensions do not include mold flash or protrusion not to exceed 0,15.
 D. Falls within JEDEC MO-153

IMPORTANT NOTICE

Texas Instruments Incorporated and its subsidiaries (TI) reserve the right to make corrections, modifications, enhancements, improvements, and other changes to its products and services at any time and to discontinue any product or service without notice. Customers should obtain the latest relevant information before placing orders and should verify that such information is current and complete. All products are sold subject to TI's terms and conditions of sale supplied at the time of order acknowledgment.

TI warrants performance of its hardware products to the specifications applicable at the time of sale in accordance with TI's standard warranty. Testing and other quality control techniques are used to the extent TI deems necessary to support this warranty. Except where mandated by government requirements, testing of all parameters of each product is not necessarily performed.

TI assumes no liability for applications assistance or customer product design. Customers are responsible for their products and applications using TI components. To minimize the risks associated with customer products and applications, customers should provide adequate design and operating safeguards.

TI does not warrant or represent that any license, either express or implied, is granted under any TI patent right, copyright, mask work right, or other TI intellectual property right relating to any combination, machine, or process in which TI products or services are used. Information published by TI regarding third-party products or services does not constitute a license from TI to use such products or services or a warranty or endorsement thereof. Use of such information may require a license from a third party under the patents or other intellectual property of the third party, or a license from TI under the patents or other intellectual property of TI.

Reproduction of information in TI data books or data sheets is permissible only if reproduction is without alteration and is accompanied by all associated warranties, conditions, limitations, and notices. Reproduction of this information with alteration is an unfair and deceptive business practice. TI is not responsible or liable for such altered documentation.

Resale of TI products or services with statements different from or beyond the parameters stated by TI for that product or service voids all express and any implied warranties for the associated TI product or service and is an unfair and deceptive business practice. TI is not responsible or liable for any such statements.

Following are URLs where you can obtain information on other Texas Instruments products and application solutions:

Products		Applications	
Amplifiers	amplifier.ti.com	Audio	www.ti.com/audio
Data Converters	dataconverter.ti.com	Automotive	www.ti.com/automotive
DSP	dsp.ti.com	Broadband	www.ti.com/broadband
Interface	interface.ti.com	Digital Control	www.ti.com/digitalcontrol
Logic	logic.ti.com	Military	www.ti.com/military
Power Mgmt	power.ti.com	Optical Networking	www.ti.com/opticalnetwork
Microcontrollers	microcontroller.ti.com	Security	www.ti.com/security
		Telephony	www.ti.com/telephony
		Video & Imaging	www.ti.com/video
		Wireless	www.ti.com/wireless

Mailing Address: Texas Instruments
Post Office Box 655303 Dallas, Texas 75265