

# Advanced Voltage Mode Pulse Width Modulator

## FEATURES

- 700kHz Operation
- Integrated Oscillator/ Voltage Feed Forward Compensation
- Accurate Duty Cycle Limit
- Accurate Volt-second Clamp
- Optocoupler Interface
- Fault Counting Shutdown
- Fault Latch off or Automatic Shutdown
- Soft Stop Optimized for Synchronous Rectification
- 1A Peak Gate Drive Output
- 130 $\mu$ A Start-up Current
- 750 $\mu$ A Operating Current

## DESCRIPTION

The UCC35701/UCC35702 family of pulse width modulators is intended for isolated switching power supplies using primary side control. They can be used for both off-line applications and DC/DC converter designs such as in a distributed power system architecture or as a telecom power source.

The devices feature low startup current, allowing for efficient off-line starting, yet have sufficient output drive to switch power MOSFETs in excess of 500kHz.

Voltage feed forward compensation is operational over a 5:1 input range and provides fast and accurate response to input voltage changes over a 4:1 range. An accurate volt-second clamp and maximum duty cycle limit are also featured.

Fault protection is provided by pulse by pulse current limiting as well as the ability to latch off after a programmable number of repetitive faults has occurred.

Two UVLO options are offered. UCC35701 family has turn-on and turn-off thresholds of 13V/9V and UCC35702 family has thresholds of 9.6V/8.8V.

The UCC35701/2 and the UCC25701/2 are offered in the 14 pin SOIC (D), 14 pin PDIP (N) or in 14 pin TSSOP (PW) packages. The UCC15701/2 is offered in the 14 pin CDIP (J) package.

## TYPICAL APPLICATION DIAGRAM

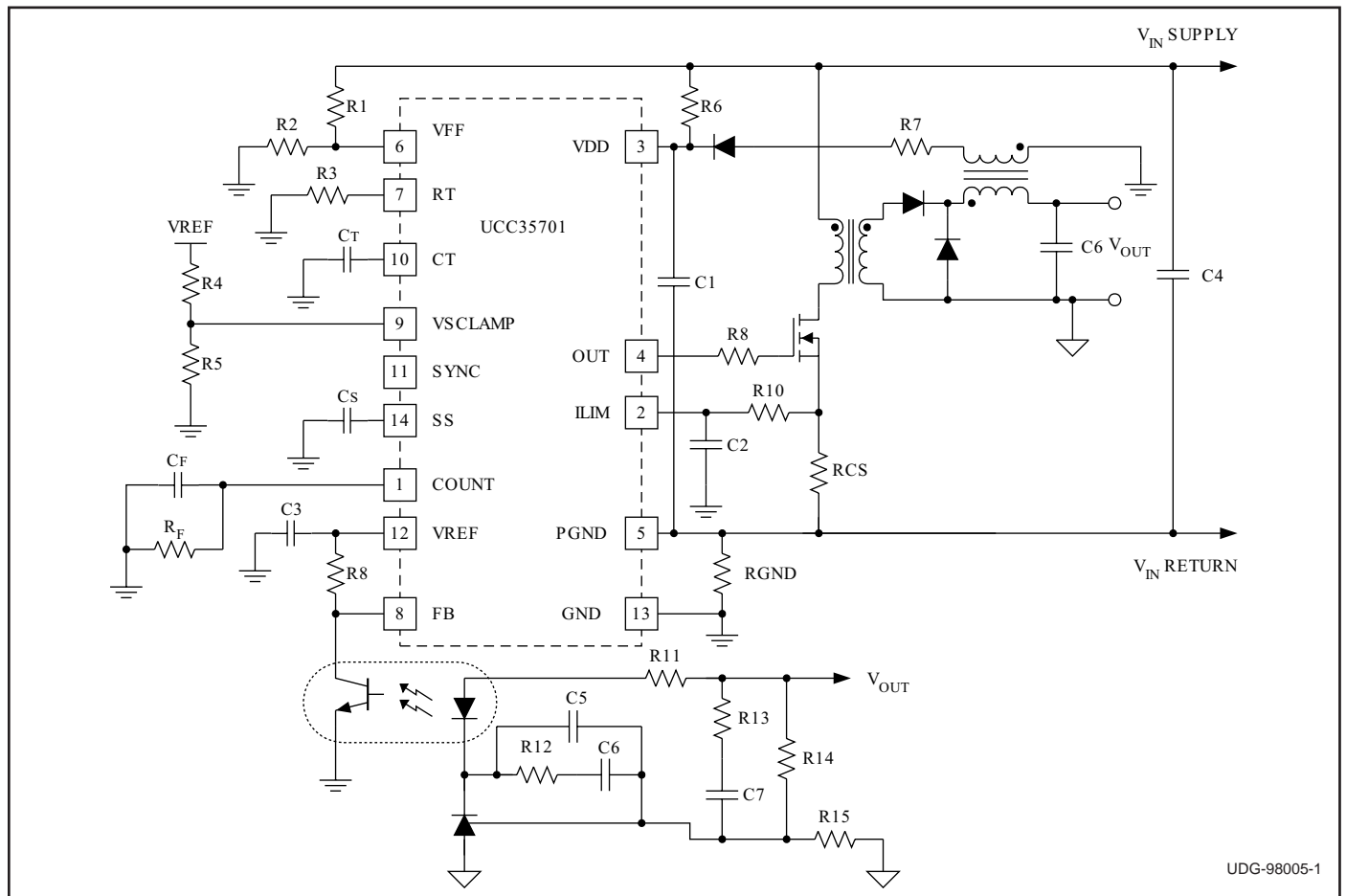

UDG-98005-1

**ABSOLUTE MAXIMUM RATINGS**

Supply voltage (Supply current limited to 20mA) . . . . . 15V  
 Supply Current. . . . . 20mA  
 Input pins ( ILIM,VFF,RT,CT,VSCLAMP,SYNC,SS, FB) . . . 6V  
 Output Current (OUT) DC. . . . . +/-180mA  
 Output Current (OUT) Pulse (0.5ms) . . . . . +/-1.2A  
 Storage Temperature. . . . . -65°C to +150°C  
 Junction Temperature. . . . . -55°C to +150°C  
 Lead Temperature (Soldering, 10 sec.) . . . . . +300°C

Note: All voltages are with respect to GND. Currents are positive into the specified terminal. Consult Packaging Section of the Databook for thermal limitations and considerations of packages.

**CONNECTION DIAGRAMS**

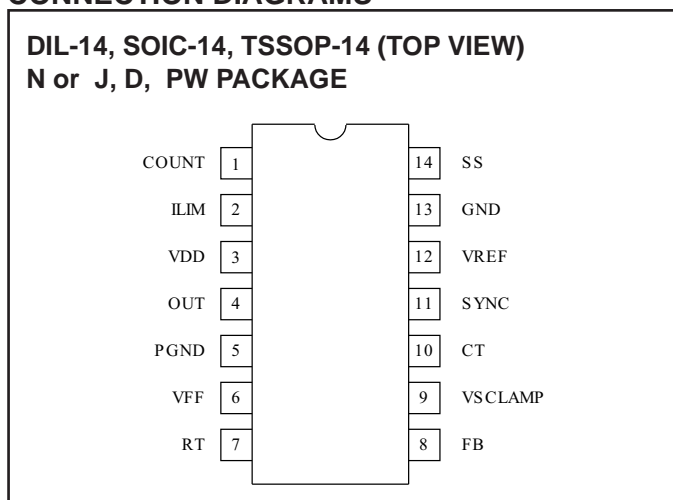

**ORDERING INFORMATION**

T <sub>A</sub> = T <sub>J</sub>	UVLO Option	Package	Part Number
-55°C to +125°C	13V / 9V	CDIP-14	UCC15701J
	9.6V / 8.8V	CDIP-14	UCC15702J
-40°C to +85°C	13V / 9V	SOIC-14	UCC25701D
		PDIP-14	UCC25701N
		TSSOP-14	UCC25701PW
	9.6V / 8.8V	SOIC-14	UCC25702D
		PDIP-14	UCC25702N
		TSSOP-14	UCC25702PW
0°C to +70°C	13V / 9V	SOIC-14	UCC35701D
		PDIP-14	UCC35701N
		TSSOP-14	UCC35701PW
	9.6V / 8.8V	SOIC-14	UCC35702D
		PDIP-14	UCC35702N
		TSSOP-14	UCC35702PW

The D and PW packages are available taped and reeled. Add TR suffix to the device type (e.g., UCC35701DTR).

**ELECTRICAL CHARACTERISTICS:** Unless otherwise specified, V<sub>DD</sub> = 11V, RT = 60.4k, C<sub>T</sub> = 330pF, C<sub>REF</sub> = C<sub>VDD</sub> = 0.1 F, V<sub>FF</sub> = 2.0V, and no load on the outputs.

PARAMETER	TEST CONDITIONS	MIN	TYP	MAX	UNITS
<b>UVLO Section</b>					
Start Threshold	(UCCX5701)	12	13	14	V
	(UCCX5702)	8.8	9.6	10.4	V
Stop Threshold	(UCCX5701)	8	9	10	V
	(UCCX5702)	8.0	8.8	9.6	V
Hysteresis	(UCCX5701)	3	4		V
	(UCCX5702)	0.3	0.8		V
<b>Supply Current</b>					
Start-up Current	(UCCX5701) V <sub>DD</sub> = 11V, V <sub>DD</sub> Comparator Off		130	200	μA
	(UCCX5702) V <sub>DD</sub> = 8V, V <sub>DD</sub> Comparator Off		120	190	μA
I <sub>DD</sub> Active	V <sub>DD</sub> Comparator On		0.75	1.5	mA
V <sub>DD</sub> Clamp Voltage	(UCCX5701) I <sub>DD</sub> = 10mA	13.5	14.3	15	V
	(UCCX5702) I <sub>DD</sub> = 10mA	13	13.8	15	V
V <sub>DD</sub> Clamp – Start Threshold	(UCCX5701)		1.3		V
	(UCCX5702)		4.2		V
<b>Voltage Reference</b>					
V <sub>REF</sub>	V <sub>DD</sub> = 10V to 13V, I <sub>VREF</sub> = 0mA to 2mA	4.9	5	5.1	V
Line Regulation	V <sub>DD</sub> = 10V to 13V		20		mV
Load Regulation	I <sub>VREF</sub> = 0mA to 2mA		2		mV
Short Circuit Current	V <sub>REF</sub> = 0V, T <sub>J</sub> = 25°C		20	50	mA

**ELECTRICAL CHARACTERISTICS:** Unless otherwise specified,  $V_{DD} = 11V$ ,  $R_T = 60.4k$ ,  $C_T = 330pF$ ,  $C_{REF} = C_{VDD} = 0.1 F$ ,  $V_{FF} = 2.0V$ , and no load on the outputs.

PARAMETER	TEST CONDITIONS	MIN	TYP	MAX	UNITS
<b>Line Sense</b>					
V <sub>th</sub> High Line Comparator		3.9	4	4.1	V
V <sub>th</sub> Low Line Comparator		0.5	0.6	0.7	V
Input Bias Current		-100		100	nA
<b>Oscillator Section</b>					
Frequency	$V_{FF} = 0.8V$ to $3.2V$	90	100	110	kHz
Frequency	$V_{FF} = 0.6V$ to $3.4V$ (Note 1)	90	100	110	kHz
SYNC VIH		2			V
SYNC VIL				0.8	V
SYNC Input Current	$V_{SYNC} = 2.0V$		3	10	$\mu A$
RT Voltage	$V_{FF} = 0.4V$	0.5	0.6	0.7	V
	$V_{FF} = 0.8V$	0.75	0.8	0.85	V
	$V_{FF} = 2.0V$	1.95	2.0	2.05	V
	$V_{FF} = 3.2V$	3.15	3.2	3.25	V
	$V_{FF} = 3.6V$	3.3	3.4	3.5	V
C <sub>T</sub> Peak Voltage	$V_{FF} = 0.8V$ (Note 1)		0.8		V
	$V_{FF} = 3.2V$ (Note 1)		3.2		V
C <sub>T</sub> Valley Voltage	(Note 1)		0		V
<b>Soft Start/Shutdown/Duty Cycle Control Section</b>					
I <sub>SS</sub> Charging Current		10	18	30	$\mu A$
I <sub>SS</sub> Discharging Current		300	500	750	$\mu A$
Saturation	$V_{DD} = 11V$ , IC Off		25	100	mV
<b>Fault Counter Section</b>					
Threshold Voltage	$V_{FF} = 0.8V$ to $3.2V$	3.8	4	4.2	V
Saturation Voltage	$V_{FF} = 0.8V$ to $3.2V$			100	mV
Count Charging Current		10	18	30	$\mu A$
<b>Current Limit Section</b>					
Input Bias Current		-100	0	100	nA
Current Limit Threshold		180	200	220	mV
Shutdown Threshold		500	600	700	mV
<b>Pulse Width Modulator Section</b>					
FB Pin Input Impedance	$V_{FB} = 3V$	30	50	100	k $\Omega$
Minimum Duty Cycle	$V_{FB} \leq 1V$			0	%
Maximum Duty Cycle	$V_{FB} \geq 4.5V$ , $V_{SCLAMP} \geq 2.0V$	95	99	100	%
PWM Gain	$V_{FF} = 0.8V$	35	50	70	%/V
<b>Volt Second Clamp Section</b>					
Maximum Duty Cycle	$V_{FF} = 0.8V$ , $V_{SCLAMP} = 0.6V$	69	74	79	%
Minimum Duty Cycle	$V_{FF} = 3.2V$ , $V_{SCLAMP} = 0.6V$	17	19	21	%
<b>Output Section</b>					
VOH	$I_{OUT} = -100mA$ , ( $V_{DD} - V_{OUT}$ )		0.4	1	V
VOL	$I_{OUT} = 100mA$		0.4	1	V
Rise Time	$C_{LOAD} = 1000pF$		20	100	ns
Fall Time	$C_{LOAD} = 1000pF$		20	100	ns

Note 1: Ensured by design. Not 100% tested in production.

**DETAILED BLOCK DIAGRAM**

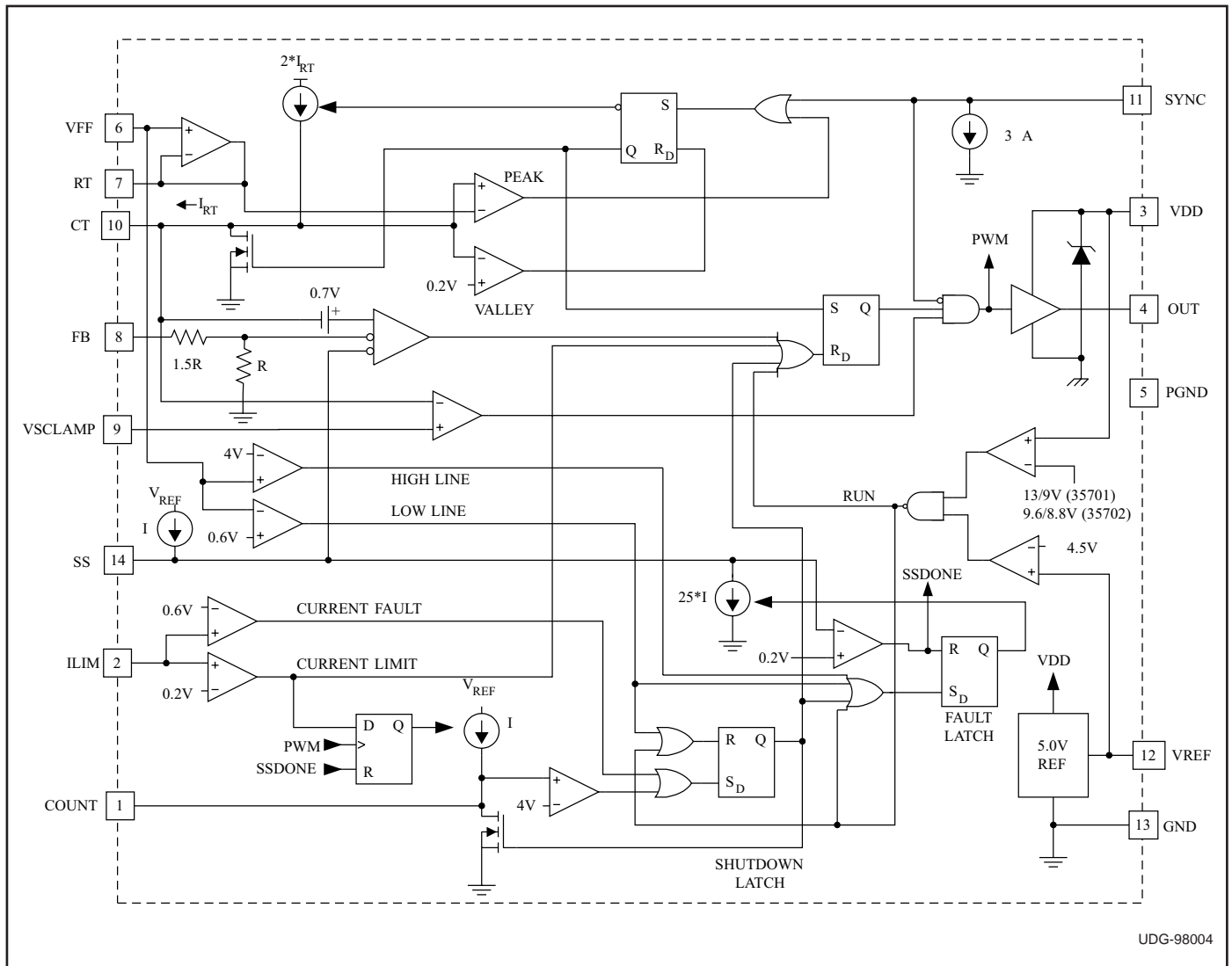

**PIN DESCRIPTIONS**

**VDD:** Power supply pin. A shunt regulator limits supply voltage to 14V typical at 10mA shunt current.

**PGND:** Power Ground. Ground return for output driver and currents.

**GND:** Analog Ground. Ground return for all other circuits. This pin must be connected directly to PGND on the board.

**OUT:** Gate drive output. Output resistance is 10Ω maximum.

**VFF:** Voltage feedforward pin. This pin connects to the power supply input voltage through a resistive divider and provides feedforward compensation over a 0.8V to 3.2V range. A voltage greater than 4.0V or less than 0.6V on this pin initiates a soft stop cycle.

**RT:** The voltage on this pin mirrors VFF over a 0.8V to 3.2V range. A resistor to ground sets the ramp capacitor charge current. The resistor value should be between 20k and 200k.

**CT:** A capacitor to ground provides the oscillator/feedforward sawtooth waveform. Charge current is  $2 \cdot I_{RT}$ , resulting in a CT slope proportional to the input voltage. The ramp voltage range is GND to  $V_{RT}$ .

Period and oscillator frequency is given by:

$$T = \frac{V_{RT} \cdot C_T}{2 \cdot I_{RT}} + t_{DISCH} \approx 0.5 \cdot R_T \cdot C_T$$

$$F \approx \frac{2}{R_T \cdot C_T}$$

## PIN DESCRIPTIONS (cont.)

**VSCLAMP:** Voltage at this pin is compared to the CT voltage, providing a constant volt-second limit. The comparator output terminates the PWM pulse when the ramp voltage exceeds VSCLAMP. The maximum on time is given by:

$$t_{ON} = \frac{V_{VSCLAMP} \cdot CT}{2 \cdot I_{RT}}$$

The maximum duty cycle limit is given by:

$$D_{MAX} = \frac{t_{ON}}{T} = \frac{V_{VSCLAMP}}{V_{RT}}$$

**FB:** Input to the PWM comparator. This pin is intended to be driven with an optocoupler circuit. Input impedance is 50kΩ. Typical modulation range is 1.6V to 3.6V.

**SYNC:** Level sensitive oscillator sync input. A high level forces the gate drive output low and resets the ramp capacitor. On-time starts at the negative edge the pulse. There is a 3μA pull down current on the pin, allowing it to be disconnected when not used.

**VREF:** 5.0V trimmed reference with 2% variation over line, load and temperature. Bypass with a minimum of 0.1μF to ground.

**SS:** Soft Start pin. A capacitor is connected between this pin and ground to set the start up time of the converter. After power up ( $V_{DD} > 13V$  AND  $V_{REF} > 4.5V$ ), or after a fault condition has been cleared, the soft start capacitor is charged to  $V_{REF}$  by a nominal 18μA internal current

source. While the soft start capacitor is charging, and while  $V_{SS} < (0.4 \cdot V_{FB})$ , the duty cycle, and therefore the output voltage of the converter is determined by the soft start circuitry.

At High Line or Low Line fault conditions, the soft start capacitor is discharged with a controlled discharge current of about 500μA. During the discharge time, the duty cycle of the converter is gradually decreased to zero. This soft stop feature allows the synchronous rectifiers to gradually discharge the output LC filter. An abrupt shut off can cause the LC filter to oscillate, producing unpredictable output voltage levels.

All other fault conditions (UVLO, VREF Low, Over Current (0.6V on ILIM) or COUNT) will cause an immediate stop of the converter. Furthermore, both the Over Current fault and the COUNT fault will be internally latched until  $V_{DD}$  drops below 9V or  $V_{FF}$  goes below the 600mV threshold at the input of the Low Line comparator.

After all fault conditions are cleared and the soft start capacitor is discharged below 200 mV, a soft start cycle will be initiated to restart the converter.

**ILIM:** Provides a pulse by pulse current limit by terminating the PWM pulse when the input is above 200mV. An input over 600mV initiates a latched soft stop cycle.

**COUNT:** Capacitor to ground integrates current pulses generated when ILIM exceeds 200mV. A resistor to ground sets the discharge time constant. A voltage over 4V will initiate a latched soft stop cycle.

## APPLICATION INFORMATION

(Note: Refer to the Typical Application Diagram on the first page of this datasheet for external component names.) All the equations given below should be considered as first order approximations with final values determined empirically for a specific application.

### Power Sequencing

$V_{DD}$  is normally connected through a high impedance (R6) to the input line, with an additional path (R7) to a low voltage bootstrap winding on the power transformer.  $V_{FF}$  is connected through a divider (R1/R2) to the input line.

For circuit activation, all of the following conditions are required:

1.  $V_{FF}$  between 0.6V and 4.0V (operational input voltage range).
2.  $V_{DD}$  has been under the UVLO stop threshold to reset the shutdown latch.
3.  $V_{DD}$  is over the UVLO start threshold.

The circuit will start at this point.  $I_{VDD}$  will increase from the start up value of 130μA to the run value of 750μA. The capacitor on SS is charged with a 18μA current. When the voltage on SS is greater than 0.8V, output pulses can begin, and supply current will increase to a level determined by the MOSFET gate charge requirements to  $I_{VDD} \sim 1mA + QT \cdot fs$ . When the output is active, the bootstrap winding should be sourcing the supply current. If  $V_{DD}$  falls below the UVLO stop threshold, the controller will enter a shutdown sequence and turn the controller off, returning the start sequence to the initial condition.

### VDD Clamp

An internal shunt regulator clamps  $V_{DD}$  so the voltage does not exceed a nominal value of 14V. If the regulator is active, supply current must be limited to less than 20mA.

## APPLICATION INFORMATION (cont.)

### Output Inhibit

During normal operation, OUT is driven high at the start of a clock period and is driven low by voltages on CT, FB or VSCLAMP.

The following conditions cause the output to be immediately driven low until a clock period starts where none of the conditions are true:

1.  $I_{LIM} > 0.2V$
2. FB or SS is less than 0.8V

### Current Limiting

ILIM is monitored by two internal comparators. The current limit comparator threshold is 0.2V. If the current limit comparator is triggered, OUT is immediately driven low and held low for the remainder of the clock cycle, providing pulse-by-pulse over-current control for excessive loads. This comparator also causes  $C_F$  to be charged for the remainder of the clock cycle.

If repetitive cycles are terminated by the current limit comparator causing COUNT to rise above 4V, the shutdown latch is set. The COUNT integration delay feature will be bypassed by the shutdown comparator which has a 0.6V threshold. The shutdown comparator immediately sets the shutdown latch.  $R_F$  in parallel with  $C_F$  resets the COUNT integrator following transient faults.  $R_F$  must be greater than  $(4 \cdot R_4) \cdot (1 - D_{MAX})$ .

### Latched Shutdown

If ILIM rises above 0.6V, or COUNT rises to 4V, the shutdown latch will be set. This will force OUT low, discharge SS and COUNT, and reduce  $I_{DD}$  to approximately 750 $\mu$ A. When, and if,  $V_{DD}$  falls below the UVLO stop threshold, the shutdown latch will reset and  $I_{DD}$  will fall to 130 $\mu$ A, allowing the circuit to restart. If  $V_{DD}$  remains above the UVLO stop threshold (within the UVLO band), an alternate restart will occur if VFF is momentarily reduced below 1V. External shutdown commands from any source may be added into either the COUNT or ILIM pins.

### Voltage Feedforward

The voltage slope on CT is proportional to line voltage over a 4:1 range and equals  $2 \cdot V_{FF} (R_T \cdot C_T)$ . The capacitor charging current is set by the voltage across  $R_T$ .  $V(R_T)$  tracks VFF over a range of 0.8V to 3.2V. A changing line voltage will immediately change the slope of  $V(CT)$ , changing the pulse width in a proportional manner without using the feedback loop, providing excellent dynamic line regulation.

VFF is intended to operate accurately over a 4:1 range between 0.8V and 3.2V. Voltages at VFF below 0.6V or above 4.0V will initiate a soft stop cycle and a chip restart when the under/over voltage condition is removed.

### Volt-Second Clamp

A constant volt-second clamp is formed by comparing the timing capacitor ramp voltage to a fixed voltage derived from the reference. Resistors  $R_4$  and  $R_5$  set the volt-second limit. For a volt-second product defined as  $V_{IN} t_{ON(max)}$ , the required voltage at VSCLAMP is:

$$\frac{\left(\frac{R_2}{R_1 + R_2}\right) \cdot (V_{IN} \cdot t_{ON(max)})}{R_T \cdot C_T}$$

The duty cycle limit is then:

$$\frac{V_{VSCLAMP}}{V_{VFF}}, \text{ or } \frac{V_{VSCLAMP}}{V_{IN} \cdot \left(\frac{R_2}{R_1 + R_2}\right)}$$

The maximum duty cycle is realized when the feedforward voltage is set at the low end of the operating range ( $V_{FF} = 0.8V$ ).

The absolute maximum duty cycle is:

$$D_{MAX} = \frac{V_{VSCLAMP}}{0.8} = \frac{V_{REF}}{0.8} \cdot \frac{R_5}{R_4 + R_5}$$

### Frequency Set

The frequency is set by a resistor from  $R_T$  to ground and a capacitor from CT to ground. The frequency is approximately:  $F = \frac{2}{(R_T \cdot C_T)}$

External synchronization is via the SYNC pin. The pin has a 1.5V threshold, making it compatible with 5V and 3.3V CMOS logic. The input is level sensitive, with a high input forcing the oscillator ramp low and the output low. An active pull down on the SYNC pin allows it to be unconnected when not used.

### Gate Drive Output

The UCC35701/2 is capable of a 1A peak output current. Bypass with at least 0.1 $\mu$ F directly to PGND. The capacitor must have a low equivalent series resistance and inductance. The connection from OUT to the power MOSFET gate should have a 2 $\Omega$  or greater damping resistor and the distance between chip and MOSFET should be minimized. A low impedance path must be established between the MOSFET source (or ground side of the current sense resistor), the VDD capacitor and PGND. PGND should then be connected by a single path (shown as RGND) to GND.

## APPLICATION INFORMATION (cont.)

### Transitioning From UCC3570 To UCC35701

The UCC35701/2 is an advanced version of the popular, low power UCC3570 PWM. Significant improvements were made to the IC's oscillator and PWM control sections to enhance overall system performance. All of the key attributes and functional blocks of the UCC3570 were maintained in the UCC35701/2. A typical application using UCC3570 and UCC35701/2 is shown in Fig. 6 for comparison.

The advantages of the UCC35701/2 over the UCC3570 are as follows.

Improved oscillator and PWM control section.

A precise maximum volt-second clamp circuit. The UCC3570 has a dual time base between oscillator and feedforward circuitry. The integrated time base in UCC35701/2 improves the duty cycle clamp accuracy, providing better than  $\pm 5\%$  accurate volt-second clamp over full temperature range.

Separately programmable oscillator timing resistor (RT) and capacitor (CT) circuits provide a higher degree of versatility.

An independent SYNC input pin for simple external synchronization.

A smaller value filter capacitor ( $0.1\mu\text{F}$ ) can be used with the enhanced reference voltage.

UCC35701/2 is pin to pin compatible to UCC3570 but is not a direct drop-in replacement for UCC3570 sockets. The changes required to the power supply printed circuit board of for existing UCC3570 designs are minimal. For conversion, only one extra resistor to set the volt-second clamp needs to be added to the existing PC board layouts. In addition, some component values will need to be changed due to the functionality change in of four of the IC pins.

The Pinout Changes from UCC3570 are as follows.

Pin 7 was changed from SLOPE to RT (for timing resistor)

Pin 8 was changed from ISET to VSCLAMP (requiring one additional resistor from pin 9 to VREF)

Pin 10 was changed from RAMP to CT (single timing capacitor)

Pin 11 was changed from FREQ to SYNC (input only)

### Additional Information

Please refer to the following two Unitrode application topics on UCC3570 for additional information.

[1] Application Note U-150, Applying the UCC3570 Voltage-Mode PWM Controller to Both Off-line and DC/DC Converter Designs by Robert A. Mammano

[2] Design Note DN-62, Switching Power Supply Topology, Voltage Mode vs. Current Mode by Robert Mammano

## TYPICAL WAVEFORMS

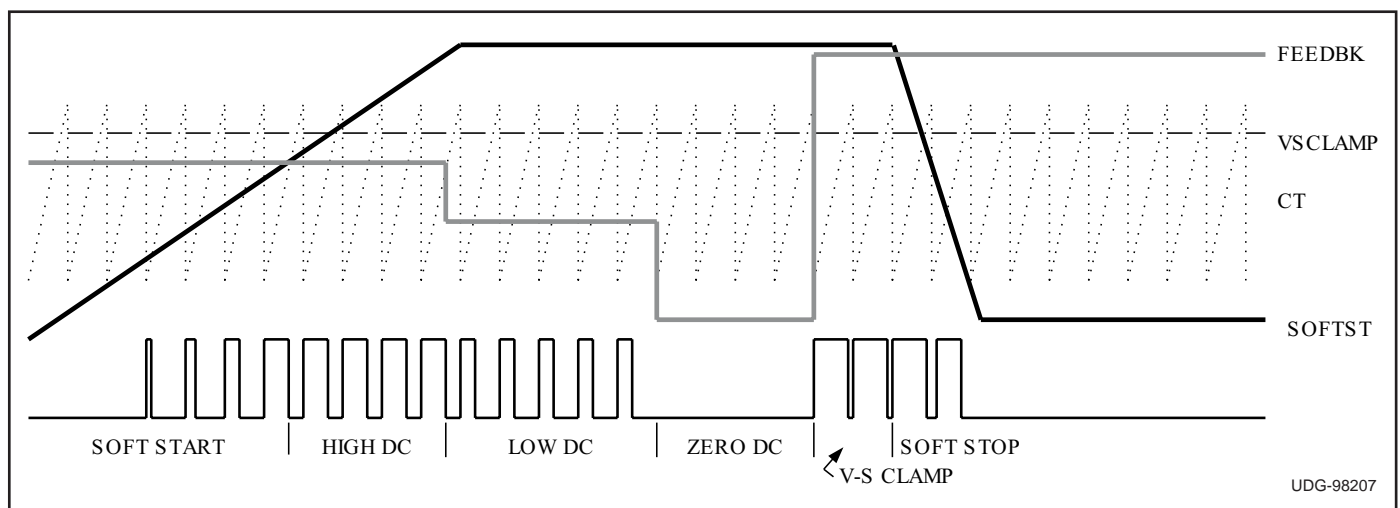

Figure 1. Timing diagram for PWM action with forward, soft start and volt-second clamp.

TYPICAL WAVEFORMS (cont.)

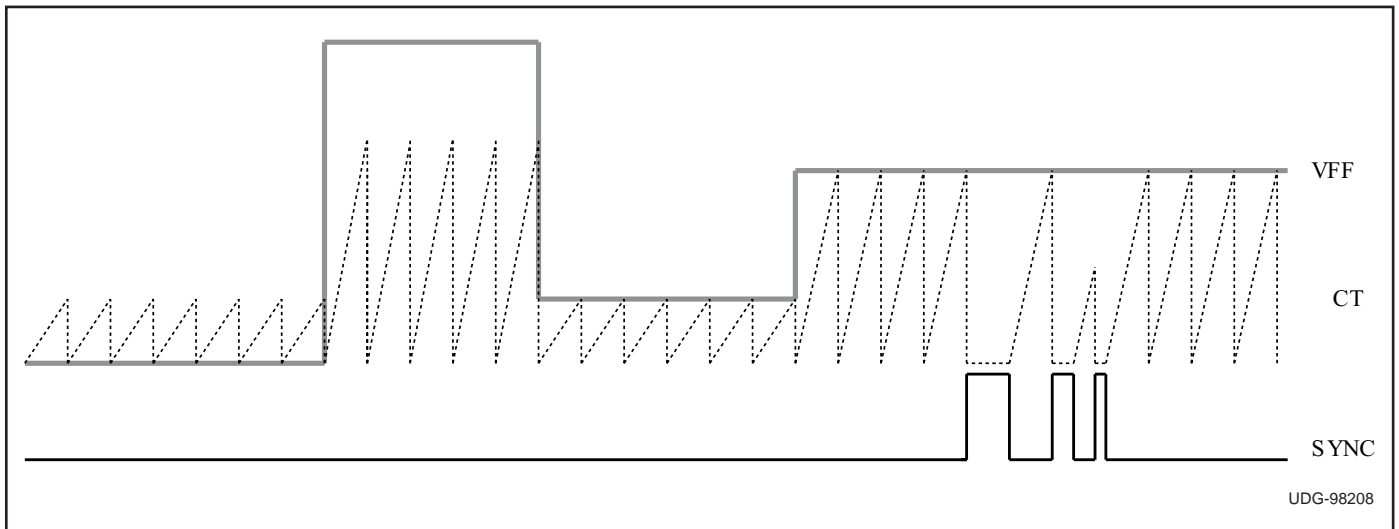

Figure 2. Timing diagram for oscillator waveforms showing feedforward action and synchronization.

TYPICAL CHARACTERISTIC CURVES

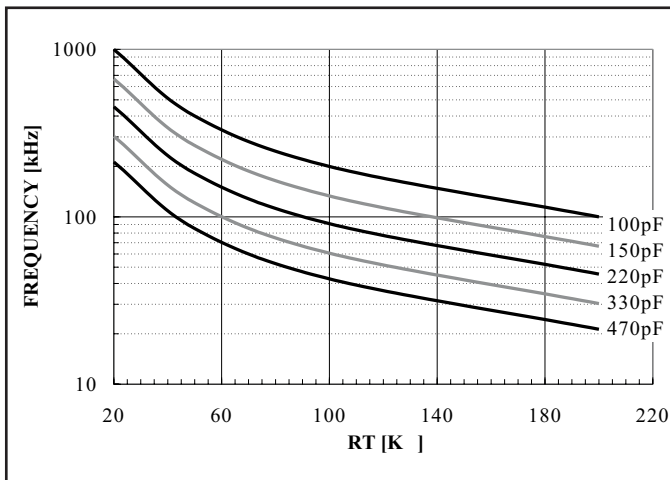

Figure 3. Oscillator frequency vs. RT and CT.

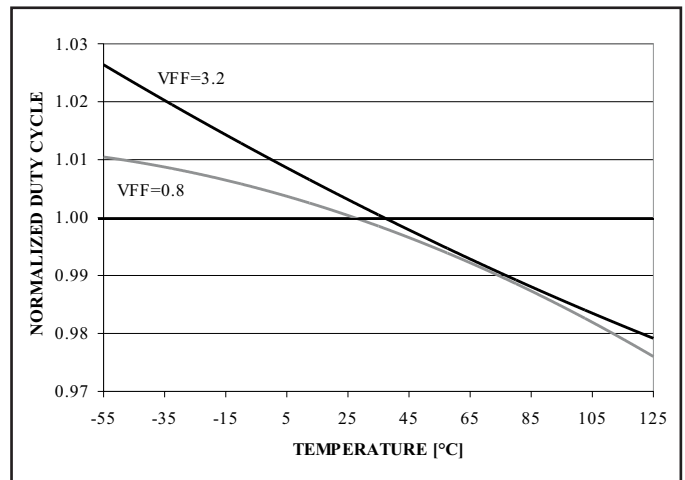

Figure 5. Normalized maximum duty cycle vs. temperature.

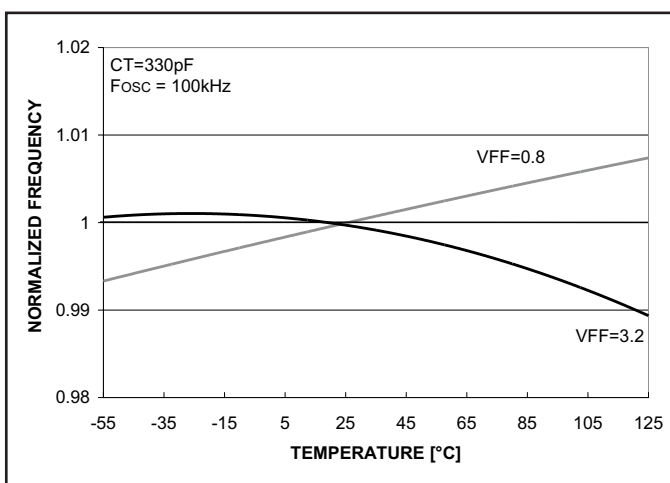
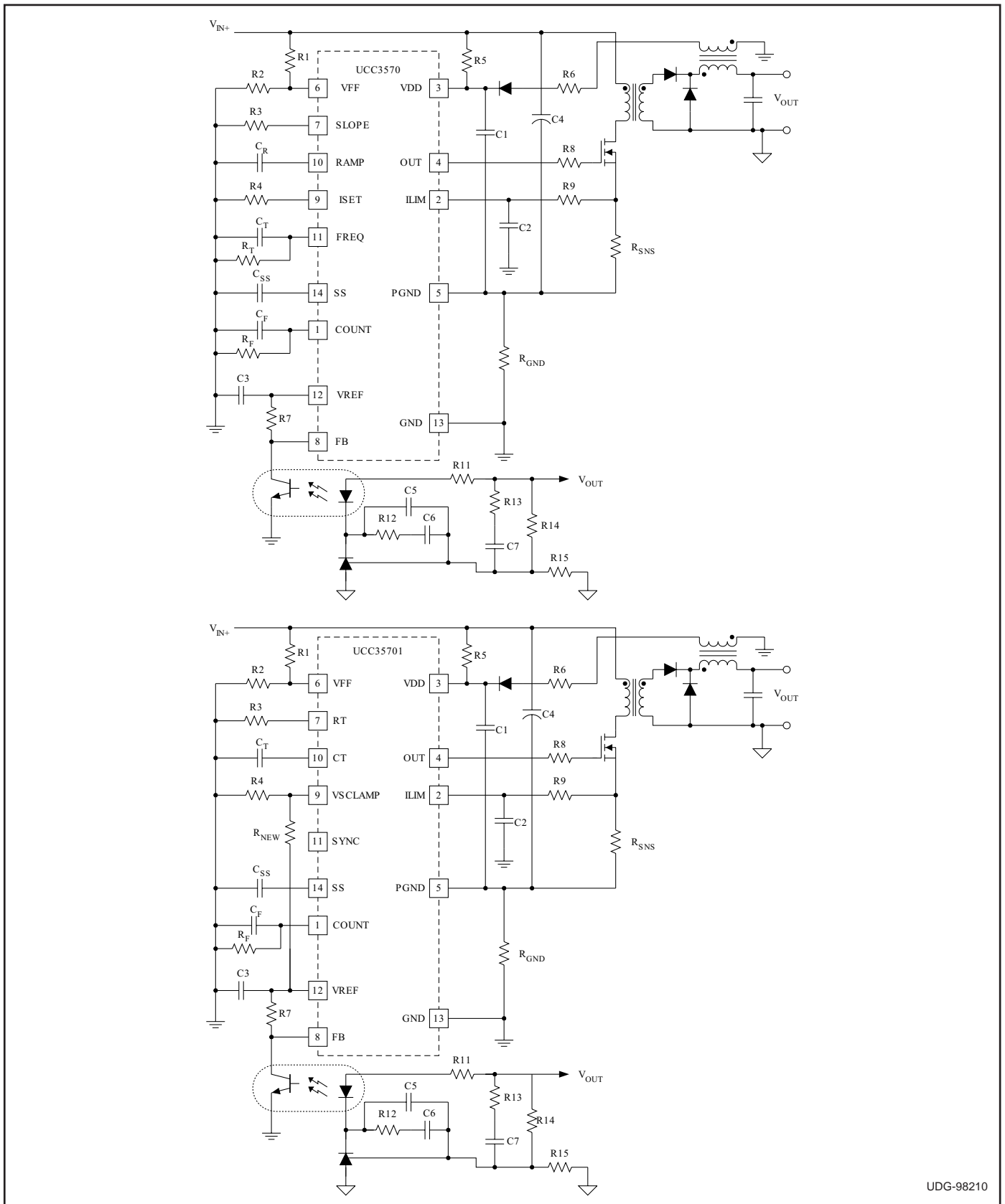

Figure 4. Oscillator frequency vs. temperature.

APPLICATION INFORMATION (cont.)



UDG-98210

Figure 6. Single-ended forward circuit comparison between UCC3750 and UCC37501.

**REVISION HISTORY**

<b>DATE</b>	<b>REVISION</b>	<b>REASON</b>
02/16/05	SLUS293B	Add FB to abs max table. Created revision history table

## IMPORTANT NOTICE

Texas Instruments Incorporated and its subsidiaries (TI) reserve the right to make corrections, modifications, enhancements, improvements, and other changes to its products and services at any time and to discontinue any product or service without notice. Customers should obtain the latest relevant information before placing orders and should verify that such information is current and complete. All products are sold subject to TI's terms and conditions of sale supplied at the time of order acknowledgment.

TI warrants performance of its hardware products to the specifications applicable at the time of sale in accordance with TI's standard warranty. Testing and other quality control techniques are used to the extent TI deems necessary to support this warranty. Except where mandated by government requirements, testing of all parameters of each product is not necessarily performed.

TI assumes no liability for applications assistance or customer product design. Customers are responsible for their products and applications using TI components. To minimize the risks associated with customer products and applications, customers should provide adequate design and operating safeguards.

TI does not warrant or represent that any license, either express or implied, is granted under any TI patent right, copyright, mask work right, or other TI intellectual property right relating to any combination, machine, or process in which TI products or services are used. Information published by TI regarding third-party products or services does not constitute a license from TI to use such products or services or a warranty or endorsement thereof. Use of such information may require a license from a third party under the patents or other intellectual property of the third party, or a license from TI under the patents or other intellectual property of TI.

Reproduction of information in TI data books or data sheets is permissible only if reproduction is without alteration and is accompanied by all associated warranties, conditions, limitations, and notices. Reproduction of this information with alteration is an unfair and deceptive business practice. TI is not responsible or liable for such altered documentation.

Resale of TI products or services with statements different from or beyond the parameters stated by TI for that product or service voids all express and any implied warranties for the associated TI product or service and is an unfair and deceptive business practice. TI is not responsible or liable for any such statements.

Following are URLs where you can obtain information on other Texas Instruments products and application solutions:

<b>Products</b>		<b>Applications</b>	
Amplifiers	<a href="http://amplifier.ti.com">amplifier.ti.com</a>	Audio	<a href="http://www.ti.com/audio">www.ti.com/audio</a>
Data Converters	<a href="http://dataconverter.ti.com">dataconverter.ti.com</a>	Automotive	<a href="http://www.ti.com/automotive">www.ti.com/automotive</a>
DSP	<a href="http://dsp.ti.com">dsp.ti.com</a>	Broadband	<a href="http://www.ti.com/broadband">www.ti.com/broadband</a>
Interface	<a href="http://interface.ti.com">interface.ti.com</a>	Digital Control	<a href="http://www.ti.com/digitalcontrol">www.ti.com/digitalcontrol</a>
Logic	<a href="http://logic.ti.com">logic.ti.com</a>	Military	<a href="http://www.ti.com/military">www.ti.com/military</a>
Power Mgmt	<a href="http://power.ti.com">power.ti.com</a>	Optical Networking	<a href="http://www.ti.com/opticalnetwork">www.ti.com/opticalnetwork</a>
Microcontrollers	<a href="http://microcontroller.ti.com">microcontroller.ti.com</a>	Security	<a href="http://www.ti.com/security">www.ti.com/security</a>
		Telephony	<a href="http://www.ti.com/telephony">www.ti.com/telephony</a>
		Video & Imaging	<a href="http://www.ti.com/video">www.ti.com/video</a>
		Wireless	<a href="http://www.ti.com/wireless">www.ti.com/wireless</a>

Mailing Address: Texas Instruments  
Post Office Box 655303 Dallas, Texas 75265