

DUAL CHANNEL SYNCHRONIZED CURRENT-MODE PWM

FEATURES

- Single Oscillator Synchronizes Two PWMs
- 150- μ A Startup Supply Current
- 2-mA Operating Supply Current
- Operation to 1 MHz
- Internal Soft-Start
- Full-Cycle Fault Restart
- Internal Leading-Edge Blanking of the Current Sense Signal
- 1-A Totem Pole Outputs
- 75-ns Typical Response from Current Sense to Output
- 1.5% Tolerance Voltage Reference

DESCRIPTION

The UCC3810 is a high-speed BiCMOS controller integrating two synchronized pulse width modulators for use in off-line and dc-to-dc power supplies. The UCC3810 family provides perfect synchronization between two PWMs by using the same oscillator. The oscillator's sawtooth waveform can be used for slope compensation if required.

Using a toggle flip-flop to alternate between modulators, the UCC3810 ensures that one PWM does not slave, interfere, or otherwise affect the other PWM. This toggle flip-flop also ensures that each PWM is limited to 50% maximum duty cycle, insuring adequate off-time to reset magnetic elements. This device contains many of the same elements of the UC3842 current mode controller family, combined with the enhancements of the UCC3802. This minimizes power supply parts count. Enhancements include leading edge blanking of the current sense signals, full cycle fault restart, CMOS output drivers, and outputs which remain low even when the supply voltage is removed.

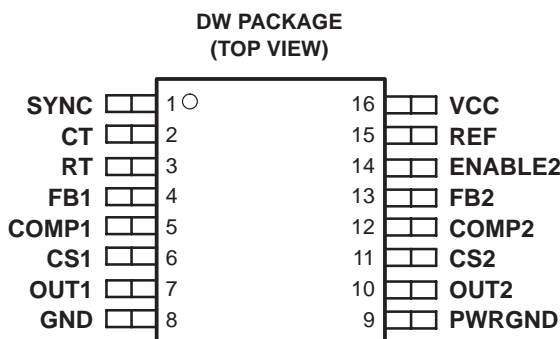
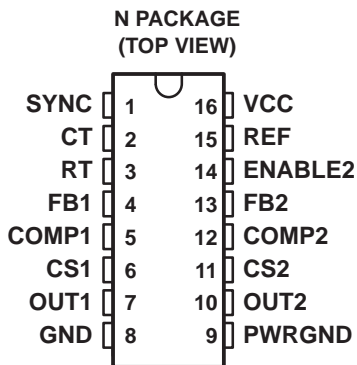

ERROR AMPLIFIER GAIN AND PHASE vs FREQUENCY

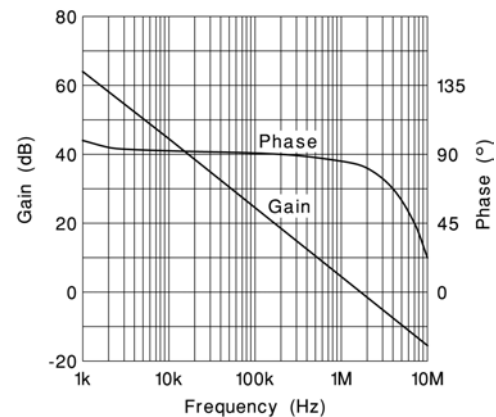

UCC2810, UCC3810

SLUS162C – FEBRUARY 1999 – REVISED NOVEMBER 2004

ORDERING INFORMATION

T _J	PACKAGED DEVICES ⁽¹⁾	
	SOP (DW)	PDIP (N)
-40°C to 85°C	UCC2810DW (16)	UCC2810N (16)
0°C to 70°C	UCC3810DW (16)	UCC3810N (16)

(1) All packages are available taped and reeled (indicated by the R suffix on the device type e.g., UCC2810JR)

ABSOLUTE MAXIMUM RATINGS

over operating free-air temperature range unless otherwise noted⁽¹⁾⁽³⁾

		UNIT
Supply voltage ⁽²⁾ , V _{CC}	11	V
Supply current, I _{CC}	20	mA
Output peak current, OUT1, OUT2, 5% duty cycle	±1	A
Output energy, OUT1, OUT2, capacitive load	20	μJ
Analog inputs, FB1, FB2, CS1, CS2, SYNC	-0.3 to 6.3	V
Operating junction temperature, T _J	150	°C
Storage temperature range, T _{stg}	-65 to 150	°C
Lead temperature (soldering, 10 sec)	300	°C

(1) Currents are positive into, negative out of the specified terminal. All voltages are with respect to GND.

(2) In normal operation, V_{CC} is powered through a current-limiting resistor. Absolute maximum of 11 V applies when driven from a low impedance such that the V_{CC} current does not exceed 20 mA.

(3) Stresses beyond those listed under "absolute maximum ratings" may cause permanent damage to the device. These are stress ratings only, and functional operation of the device at these or any other conditions beyond those indicated under "recommended operating conditions" is not implied. Exposure to absolute-maximum-rated conditions for extended periods may affect device reliability.

BLOCK DIAGRAM

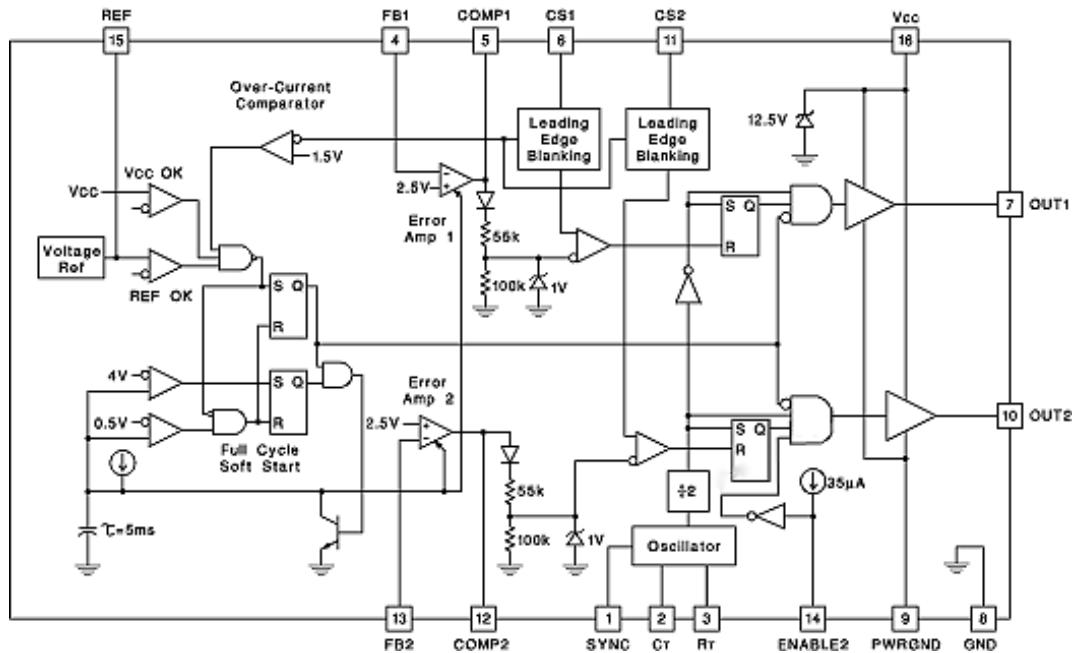

UDG-92062-2

ELECTRICAL CHARACTERISTICS

All parameters are the same for both channels, $-40^{\circ}\text{C} \leq T_A \leq 85^{\circ}\text{C}$ for the UCC2810, $0^{\circ}\text{C} \leq T_A \leq 70^{\circ}\text{C}$ for the UCC3810, $V_{CC} = 10\text{ V}^{(1)}$; $R_T = 150\text{ k}\Omega$, $C_T = 120\text{ pF}$; no load; $T_A = T_J$; (unless otherwise specified)

PARAMETER	TEST CONDITIONS	MIN	TYP	MAX	UNIT
REFERENCE					
V_{CC} Output voltage	$T_J = 25^{\circ}\text{C}$	4.925	5.000	5.075	V
	$T_J = \text{full range, } 0\text{ mA} \leq I_{REF} \leq 5\text{ mA}$	4.85	5.00	5.10	
Load regulation	$0\text{ mA} \leq I_{REF} \leq 5\text{ mA}$		5	30	mV
Line regulation	UVLO stop threshold voltage, $0.5\text{ V} \leq V_{CC} \leq V_{SHUNT}$		12		
Output noise voltage ⁽⁷⁾	$10\text{ Hz} < f < 10\text{ kHz, } T_J = 25^{\circ}\text{C}$		235		μV
Long term stability ⁽⁷⁾	$T_A = 125^{\circ}\text{C, } 1000\text{ hours}$		5		mV
$I_{O(SC)}$ Output short circuit current			-8	-25	mA
OSCILLATOR					
f_{OSC} Oscillator frequency ⁽²⁾	$R_T = 30\text{ k}\Omega$ $C_T = 120\text{ pF}$	760	880	1000	kHz
	$R_T = 150\text{ k}\Omega$ $C_T = 120\text{ pF}$	190	220	250	
Temperature stability ⁽⁷⁾			2.5%		
Peak voltage			2.5		V
Valley voltage			0.05		
Peak-to-peak amplitude		2.25	2.45	2.65	
SYNC threshold voltage		0.80	1.65	2.20	
SYNC input current	SYNC = 5 V		30		μA
ERROR AMPLIFIER					
V_{FB} FB input voltage	COMP = 2.5 V	2.44	2.50	2.56	V
I_{FB} FB input bias current				± 1	μA
Open loop voltage gain		60	73		dB
f_{GAIN} Unity gain bandwidth ⁽⁷⁾			2		MHz
I_{SINK} Sink current, COMP	FB = 2.7 V, COMP = 1 V	0.3	1.4	3.5	mA
I_{SRCE} Source current, COMP	FB = 1.8 V, COMP = 4 V	-0.2	-0.5	-0.8	
Minimum duty cycle	COMP = 0 V			0%	
Soft-start rise time, COMP	FB = 1.8 V, rise from 0.5 V to (REF - 1.5 V)		5		ms

(1) For UCC3810, adjust V_{CC} above the start threshold before setting at 10 V.

(2) Oscillator frequency is twice the output frequency. $f_{OSC} = \frac{4}{R_T \times C_T}$

(3) Current sense gain A is defined by: $A = \frac{\Delta V_{COMP}}{\Delta V_{CS}}$, $0\text{ V} \leq V_{CS} \leq 0.8\text{ V}$.

(4) Parameter measured at trip point of latch with FB = 0 V.

(5) CS blank time is measured as the difference between the minimum non-zero on-time and the CS-to-OUT delay.

(6) Start threshold voltage and V_{CC} internal zener voltage track each other.

(7) Ensured by design. Not production tested.

UCC2810, UCC3810

SLUS162C – FEBRUARY 1999 – REVISED NOVEMBER 2004

ELECTRICAL CHARACTERISTICS

All parameters are the same for both channels, $-40^{\circ}\text{C} \leq T_A \leq 85^{\circ}\text{C}$ for the UCC2810, $0^{\circ}\text{C} \leq T_A \leq 70^{\circ}\text{C}$ for the UCC3810, $V_{CC} = 10\text{ V}^{(1)}$; $R_T = 150\text{ k}\Omega$, $C_T = 120\text{ pF}$; no load; $T_A = T_J$; (unless otherwise specified)

PARAMETER	TEST CONDITIONS	MIN	TYP	MAX	UNIT
CURRENT SENSE					
Gain ⁽³⁾		1.20	1.55	1.80	V/V
Maximum input signal ⁽⁴⁾	COMP = 5 V	0.9	1.0	1.1	V
I_{CS} Input bias current, CS				±200	nA
Propagation delay time (CS to OUT)	CS steps from 0 V to 1.2 V, COMP = 2.5 V		75		ns
Blank time, CS ⁽⁵⁾			55		
Overcurrent threshold voltage, CS		1.35	1.55	1.85	V
COMP-to-CS offset voltage	CS = 0 V	0.45	0.90	1.35	
PWM					
Maximum duty cycle ⁽⁷⁾	$R_T = 150\text{ k}\Omega$, $C_T = 120\text{ pF}$	45%	49%	50%	
	$R_T = 30\text{ k}\Omega$, $C_T = 120\text{ pF}$	40%	45%	48%	
Minimum on-time	CS = 1.2 V, COMP = 5 V		130		ns
OUTPUT					
V_{OL} Low-level output voltage	$I_{OUT} = 20\text{ mA}$		0.12	0.42	V
	$I_{OUT} = 200\text{ mA}$		0.48	1.10	
	$I_{OUT} = 20\text{ mA}$, $V_{CC} = 0\text{ V}$		0.7	1.2	
V_{OH} High-level output voltage ($V_{CC} - OUT$)	$I_{OUT} = -20\text{ mA}$		0.15	0.42	ns
	$I_{OUT} = -200\text{ mA}$		1.2	2.3	
t_R Rise time, OUT	$C_{OUT} = 1\text{ nF}$		20	50	ns
t_F Fall time, OUT	$C_{OUT} = 1\text{ nF}$		30	60	
UNDERVOLTAGE LOCKOUT (UVLO)					
Start threshold voltage		9.6	11.3	13.2	V
Stop threshold voltage		7.1	8.3	9.5	
Start-to-stop hysteresis		1.7	3.0	4.7	
ENABLE2 input bias current	ENABLE2 = 0 V	-20	-35	-55	μA
ENABLE2 input threshold voltage		0.80	1.53	2.00	V

(1) For UCC3810, adjust V_{CC} above the start threshold before setting at 10 V.

(2) Oscillator frequency is twice the output frequency. $f_{osc} = \frac{4}{R_T \times C_T}$

(3) Current sense gain A, is defined by: $A = \frac{\Delta V_{COMP}}{\Delta V_{CS}}$, $0\text{ V} \leq V_{CS} \leq 0.8\text{ V}$.

(4) Parameter measured at trip point of latch with $FB = 0\text{ V}$.

(5) CS blank time is measured as the difference between the minimum non-zero on-time and the CS-to-OUT delay.

(6) Start threshold voltage and V_{CC} internal zener voltage track each other.

(7) Ensured by design. Not production tested.

ELECTRICAL CHARACTERISTICS

All parameters are the same for both channels, $-40^{\circ}\text{C} \leq T_A \leq 85^{\circ}\text{C}$ for the UCC2810, $0^{\circ}\text{C} \leq T_A \leq 70^{\circ}\text{C}$ for the UCC3810, $V_{CC} = 10\text{ V}^{(1)}$; $R_T = 150\text{ k}\Omega$, $C_T = 120\text{ pF}$; no load; $T_A = T_J$; (unless otherwise specified)

PARAMETER	TEST CONDITIONS	MIN	TYP	MAX	UNIT
OVERALL					
Startup current	$V_{CC} < \text{Start threshold voltage}$		0.15	0.25	mA
Operating supply current, outputs off	$V_{CC} = 10\text{ V}$, $\text{FB} = 2.75\text{ V}$		2	3	
Operating supply current, outputs on	$V_{CC} = 10\text{ V}$, $\text{CS} = 0\text{ V}$, $R_T = 150\text{ k}\Omega$		3.2	5.1	
	$V_{CC} = 10\text{ V}$, $\text{CS} = 0\text{ V}$, $R_T = 30\text{ k}\Omega$		8.5	14.5	
VCC internal zener voltage ⁽⁶⁾	$I_{CC} = 10\text{ mA}$	11.0	12.9	14.0	V
VCC internal zener voltage minus start threshold voltage		0.4	1.2		

(6) Start threshold voltage and V_{CC} internal zener voltage track each other.

Terminal Functions

TERMINAL		I/O	DESCRIPTION
NAME	NO.		
COMP1	5	O	Low impedance output of the error amplifiers.
COMP2	12	O	
CS1	6	I	Current sense inputs to the PWM comparators. These inputs have leading edge blanking. For most applications, no input filtering is required. Leading edge blanking disconnects the CS inputs from all internal circuits for the first 55 ns of each PWM cycle. When used with very slow diodes or in other applications where the current sense signal is unusually noisy, a small current-sense R-C filter may be required.
CS2	11	I	
CT	2	O	The timing capacitor of the oscillator. Recommended values of CT are between 100 pF and 1 nF. Connect the timing capacitor directly across CT and GND.
ENABLE2	14	I	A logic input which disables PWM 2 when low. This input has no effect on PWM 1. This input is internally pulled high. In most applications it can be left floating. In unusually noisy applications, the input should be bypassed with a 1-nF ceramic capacitor. This input has TTL compatible thresholds.
FB1	4	I	The high impedance inverting inputs of the error amplifiers.
FB2	13	I	
GND	8	–	To separate noise from the critical control circuits, this part has two different ground connections: GND and PWRGND. GND and PWRGND must be electrically connected together. However, use care to avoid coupling noise into GND.
OUT1	7	O	The high-current push-pull outputs of the PWM are intended to drive power MOSFET gates through a small resistor. This resistor acts as both a current limiting resistor and as a damping impedance to minimize ringing and overshoot.
OUT2	10	O	
PWRGND	9	–	To separate noise from the critical control circuits, this part has two different ground connections: GND and PWRGND. GND and PWRGND must be electrically connected together.
REF	15	O	The output of the 5-V reference. Bypass REF to GND with a ceramic capacitor $\geq 0.01\text{-}\mu\text{F}$ for best performance.
RT	3	O	The oscillator charging current is set by the value of the resistor connected from RT to GND. This pin is regulated to 1 V, but the actual charging current is $10\text{ V}/R_T$. Recommended values of R_T are between 10 k Ω and 470 k Ω . For a given frequency, higher timing resistors give higher maximum duty cycle and slightly lower overall power consumption.
SYNC	1	I	This logic input can be used to synchronize the oscillator to a free running oscillator in another part. This pin is edge triggered with TTL thresholds, and requires at least a 10-ns-wide pulse. If unused, this pin can be grounded, open circuited, or connected to REF.
VCC	16	I	The power input to the device. This pin supplies current to all functions including the high current output stages and the precision reference. Therefore, it is critical that VCC be directly bypassed to PWRGND with an 0.1- μF ceramic capacitor.

APPLICATION INFORMATION

timing resistor

Supply current decreases with increased R_T by the relationship:

$$\Delta I_{CC} = \frac{11 V}{R_T} \tag{1}$$

For more information, see the detailed oscillator block diagram.

leading edge blanking and current sense

Figure 1 shows how an external power stage is connected to the UCC3810. The gate of an external power N-channel MOSFET is connected to OUT through a small current-limiting resistor. For most applications, a 10-Ω resistor is adequate to limit peak current and also practical at damping resonances between the gate driver and the MOSFET input reactance. Long gate lead length increases gate capacitance and mandates a higher series gate resistor to damp the R-L-C tank formed by the lead, the MOSFET input reactance, and the device's driver output resistance.

The UCC3810 features internal leading edge blanking of the current-sense signal on both current sense inputs. The blank time starts when OUT rises and continues for 55 ns. During that 55 ns period, the signal on CS is ignored. For most PWM applications, this means that the CS input can be connected to the current-sense resistor as shown in Figure 1. However, high speed grounding practices and short lead lengths are still required for good performance.

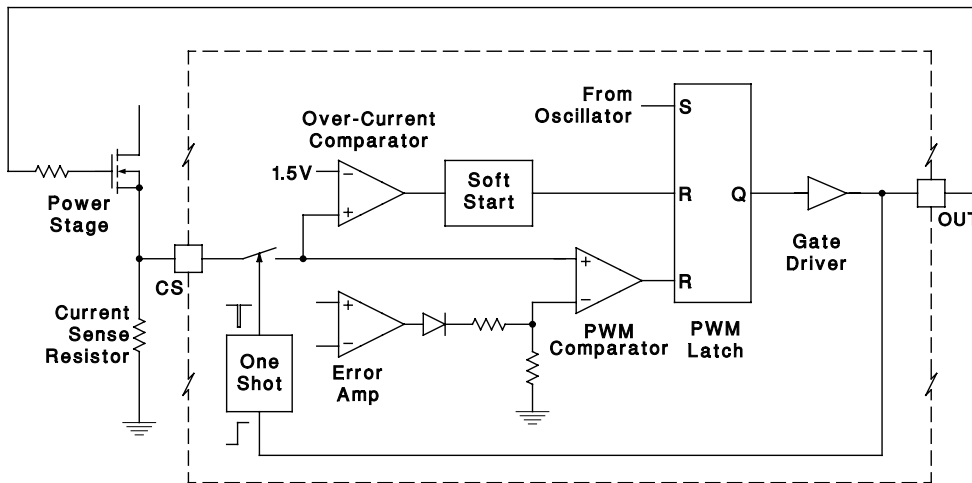

Figure 1. Detailed Block Diagram

oscillator

The UCC3810 oscillator generates a sawtooth wave at CT. The sawtooth rise time is set by the resistor from RT to GND. Since R_T is biased at 1 V, the current through R_T is $1 V/R_T$. The actual charging current is 10 times higher. The fall time is set by an internal transistor on-resistance of approximately 100 Ω. During the fall time, all outputs are off and the maximum duty cycle is reduced to below 50%. Larger timing capacitors increase the discharge time and reduce frequency. However, the percentage maximum duty cycle is only a function of the timing resistor R_T , and the internal 100-Ω discharge resistance.

APPLICATION INFORMATION

error amplifier output stage

The UCC3810 error amplifiers are operational amplifiers with low-output resistance and high-input resistance. The output stage of one error amplifier is shown in Figure 3. This output stage allows the error amplifier output to swing close to GND and as high as one diode drop below 5 V with little loss in amplifier performance.

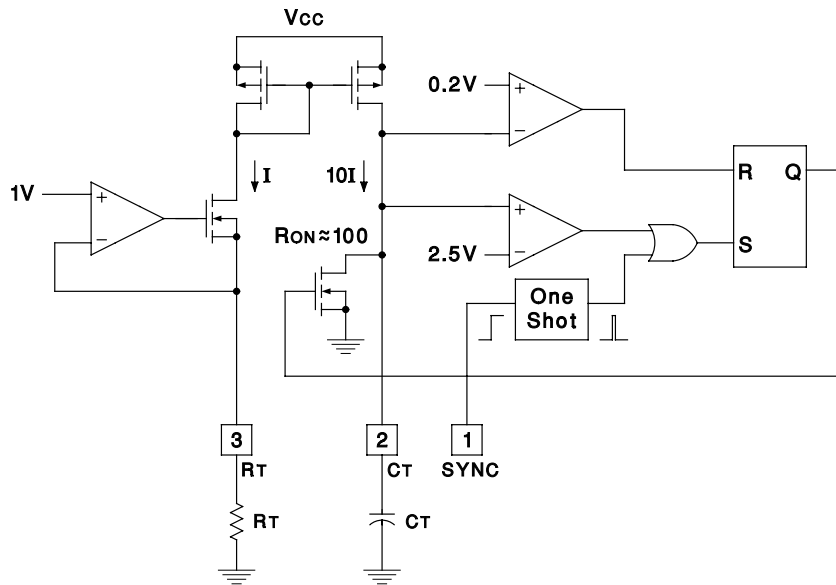

Figure 2. Oscillator

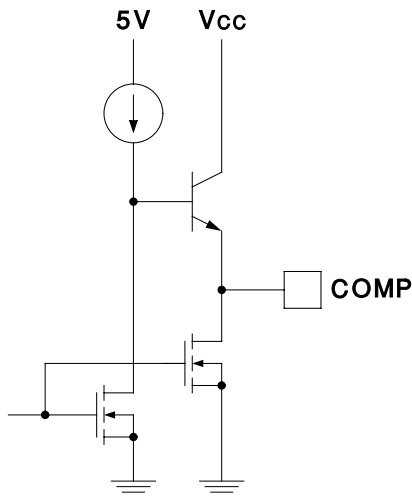

Figure 3. Error Amplifier Output Stage

TYPICAL CHARACTERISTICS

ERROR AMPLIFIER GAIN AND PHASE
VS
FREQUENCY

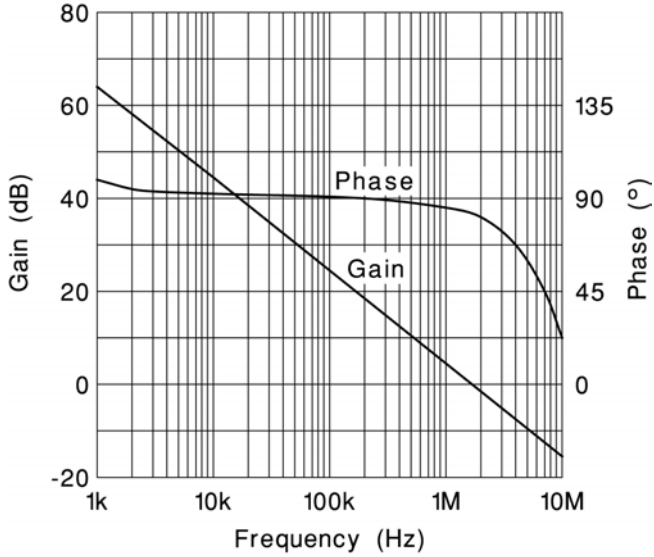

Figure 4

OSCILLATOR FREQUENCY
VS
TIMING RESISTANCE

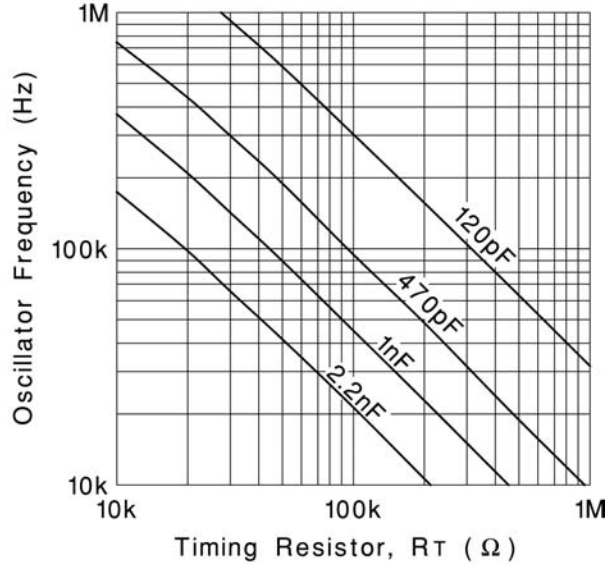

Figure 5

OSCILLATOR FREQUENCY
VS
TEMPERATURE

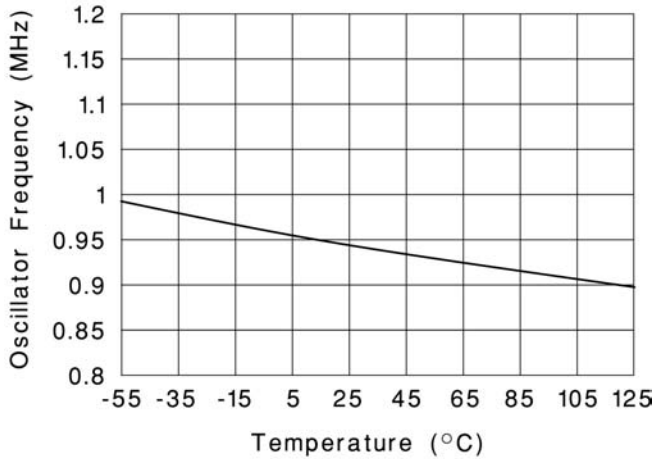

Figure 6

MAXIMUM DUTY CYCLE
VS
TIMING RESISTANCE

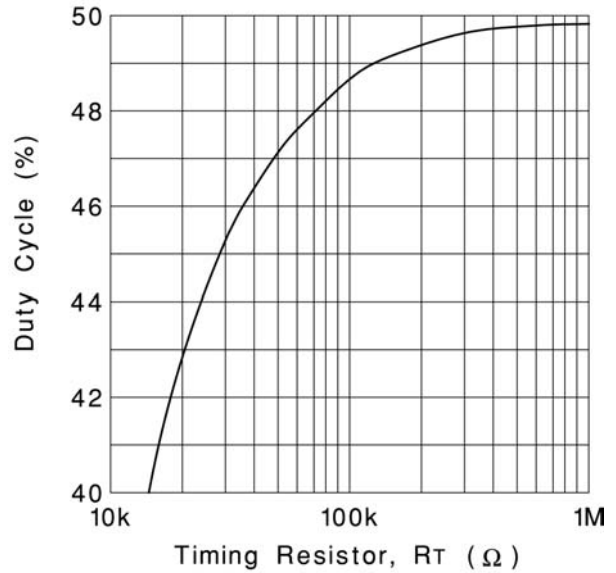

Figure 7

TYPICAL CHARACTERISTICS

INPUT CURRENT
vs
OSCILLATOR FREQUENCY

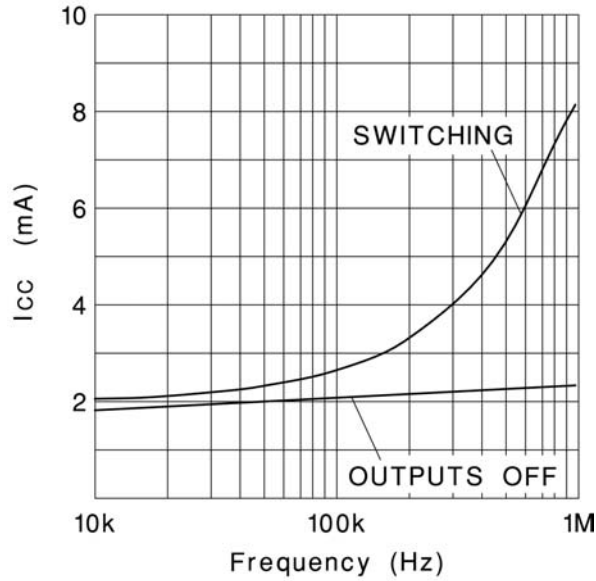

Figure 8

MAXIMUM DUTY CYCLE
vs
FREQUENCY

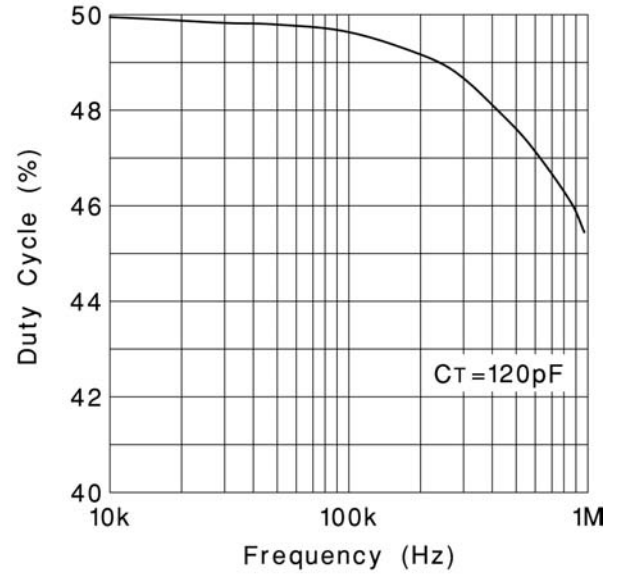
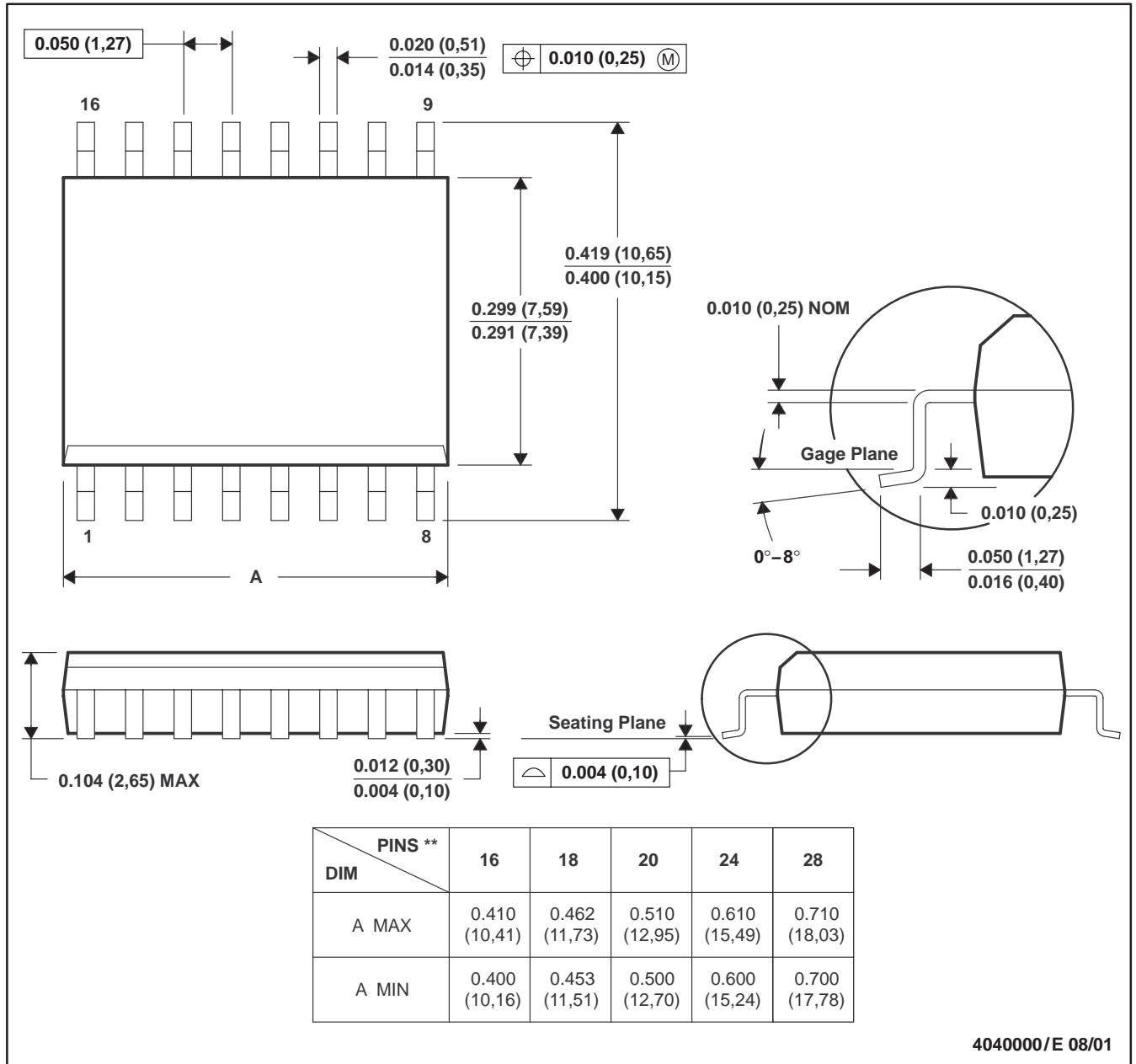

Figure 9

DW (R-PDSO-G**)

PLASTIC SMALL-OUTLINE PACKAGE

16 PINS SHOWN



- NOTES:
- A. All linear dimensions are in inches (millimeters).
 - B. This drawing is subject to change without notice.
 - C. Body dimensions do not include mold flash or protrusion not to exceed 0.006 (0,15).
 - D. Falls within JEDEC MS-013

UCC2810, UCC3810

SLUS162C – FEBRUARY 1999 – REVISED NOVEMBER 2004

N (R-PDIP-T**)

PLASTIC DUAL-IN-LINE PACKAGE

16 PINS SHOWN

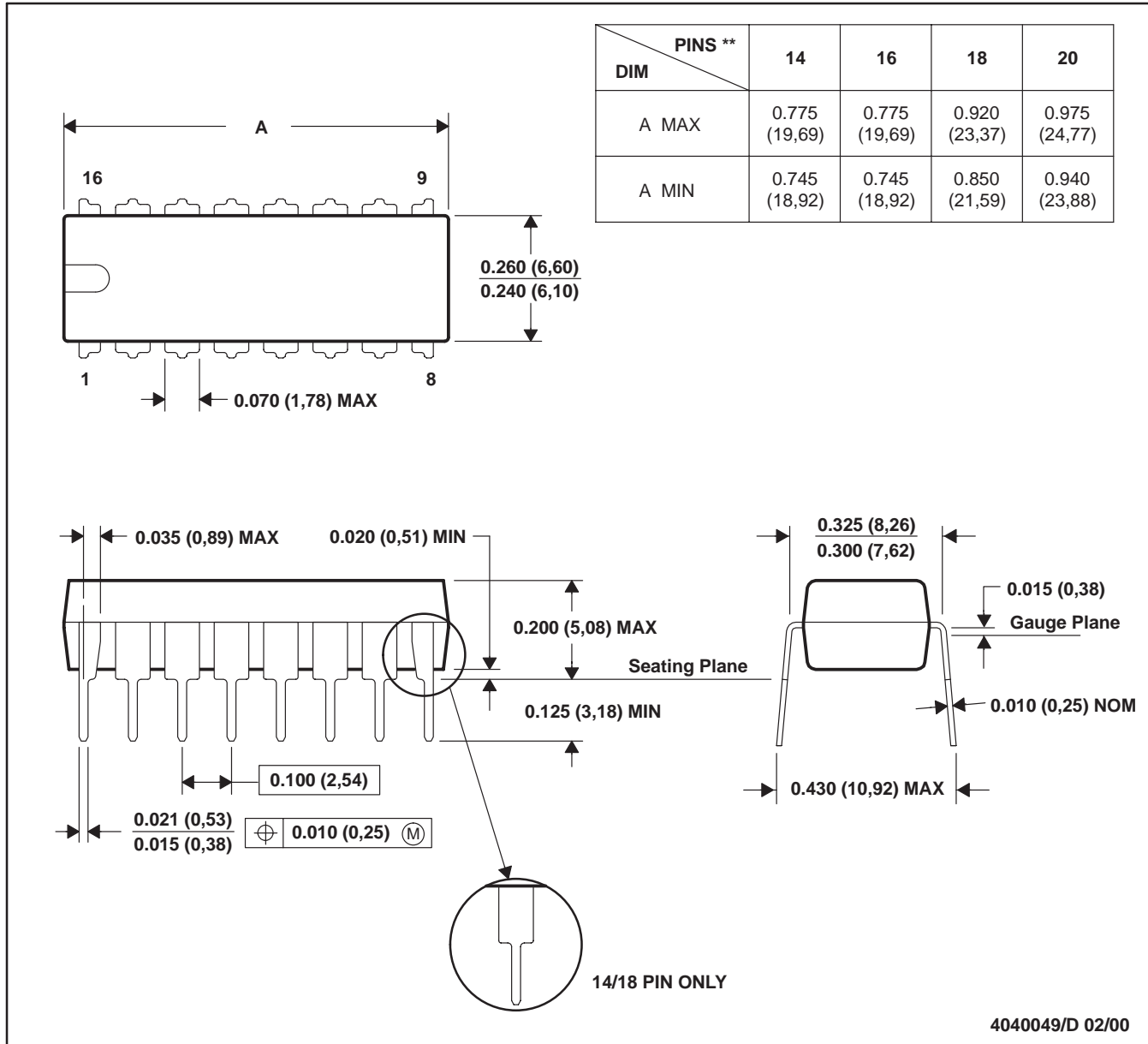

- NOTES: A. All linear dimensions are in inches (millimeters).
 B. This drawing is subject to change without notice.
 C. Falls within JEDEC MS-001 (20-pin package is shorter than MS-001).

PACKAGING INFORMATION

Orderable Device	Status ⁽¹⁾	Package Type	Package Drawing	Pins	Package Qty	Eco Plan ⁽²⁾	Lead/Ball Finish	MSL Peak Temp ⁽³⁾
UCC2810DW	ACTIVE	SOIC	DW	16	40	None	CU NIPDAU	Level-2-220C-1 YEAR
UCC2810DWTR	ACTIVE	SOIC	DW	16	2000	None	CU NIPDAU	Level-2-220C-1 YEAR
UCC2810N	ACTIVE	PDIP	N	16	25	None	CU NIPDAU	Level-NA-NA-NA
UCC3810DW	ACTIVE	SOIC	DW	16	40	None	CU NIPDAU	Level-2-220C-1 YEAR
UCC3810DWTR	ACTIVE	SOIC	DW	16	2000	None	CU NIPDAU	Level-2-220C-1 YEAR
UCC3810DWTRG4	ACTIVE	SOIC	DW	16	2000	Green (RoHS & no Sb/Br)	CU NIPDAU	Level-2-260C-1 YEAR
UCC3810N	ACTIVE	PDIP	N	16	25	None	CU NIPDAU	Level-NA-NA-NA

⁽¹⁾ The marketing status values are defined as follows:

ACTIVE: Product device recommended for new designs.

LIFEBUY: TI has announced that the device will be discontinued, and a lifetime-buy period is in effect.

NRND: Not recommended for new designs. Device is in production to support existing customers, but TI does not recommend using this part in a new design.

PREVIEW: Device has been announced but is not in production. Samples may or may not be available.

OBSELETE: TI has discontinued the production of the device.

⁽²⁾ Eco Plan - May not be currently available - please check <http://www.ti.com/productcontent> for the latest availability information and additional product content details.

None: Not yet available Lead (Pb-Free).

Pb-Free (RoHS): TI's terms "Lead-Free" or "Pb-Free" mean semiconductor products that are compatible with the current RoHS requirements for all 6 substances, including the requirement that lead not exceed 0.1% by weight in homogeneous materials. Where designed to be soldered at high temperatures, TI Pb-Free products are suitable for use in specified lead-free processes.

Green (RoHS & no Sb/Br): TI defines "Green" to mean "Pb-Free" and in addition, uses package materials that do not contain halogens, including bromine (Br) or antimony (Sb) above 0.1% of total product weight.

⁽³⁾ MSL, Peak Temp. -- The Moisture Sensitivity Level rating according to the JEDEC industry standard classifications, and peak solder temperature.

Important Information and Disclaimer:The information provided on this page represents TI's knowledge and belief as of the date that it is provided. TI bases its knowledge and belief on information provided by third parties, and makes no representation or warranty as to the accuracy of such information. Efforts are underway to better integrate information from third parties. TI has taken and continues to take reasonable steps to provide representative and accurate information but may not have conducted destructive testing or chemical analysis on incoming materials and chemicals. TI and TI suppliers consider certain information to be proprietary, and thus CAS numbers and other limited information may not be available for release.

In no event shall TI's liability arising out of such information exceed the total purchase price of the TI part(s) at issue in this document sold by TI to Customer on an annual basis.

IMPORTANT NOTICE

Texas Instruments Incorporated and its subsidiaries (TI) reserve the right to make corrections, modifications, enhancements, improvements, and other changes to its products and services at any time and to discontinue any product or service without notice. Customers should obtain the latest relevant information before placing orders and should verify that such information is current and complete. All products are sold subject to TI's terms and conditions of sale supplied at the time of order acknowledgment.

TI warrants performance of its hardware products to the specifications applicable at the time of sale in accordance with TI's standard warranty. Testing and other quality control techniques are used to the extent TI deems necessary to support this warranty. Except where mandated by government requirements, testing of all parameters of each product is not necessarily performed.

TI assumes no liability for applications assistance or customer product design. Customers are responsible for their products and applications using TI components. To minimize the risks associated with customer products and applications, customers should provide adequate design and operating safeguards.

TI does not warrant or represent that any license, either express or implied, is granted under any TI patent right, copyright, mask work right, or other TI intellectual property right relating to any combination, machine, or process in which TI products or services are used. Information published by TI regarding third-party products or services does not constitute a license from TI to use such products or services or a warranty or endorsement thereof. Use of such information may require a license from a third party under the patents or other intellectual property of the third party, or a license from TI under the patents or other intellectual property of TI.

Reproduction of information in TI data books or data sheets is permissible only if reproduction is without alteration and is accompanied by all associated warranties, conditions, limitations, and notices. Reproduction of this information with alteration is an unfair and deceptive business practice. TI is not responsible or liable for such altered documentation.

Resale of TI products or services with statements different from or beyond the parameters stated by TI for that product or service voids all express and any implied warranties for the associated TI product or service and is an unfair and deceptive business practice. TI is not responsible or liable for any such statements.

Following are URLs where you can obtain information on other Texas Instruments products and application solutions:

Products		Applications	
Amplifiers	amplifier.ti.com	Audio	www.ti.com/audio
Data Converters	dataconverter.ti.com	Automotive	www.ti.com/automotive
DSP	dsp.ti.com	Broadband	www.ti.com/broadband
Interface	interface.ti.com	Digital Control	www.ti.com/digitalcontrol
Logic	logic.ti.com	Military	www.ti.com/military
Power Mgmt	power.ti.com	Optical Networking	www.ti.com/opticalnetwork
Microcontrollers	microcontroller.ti.com	Security	www.ti.com/security
		Telephony	www.ti.com/telephony
		Video & Imaging	www.ti.com/video
		Wireless	www.ti.com/wireless

Mailing Address: Texas Instruments
Post Office Box 655303 Dallas, Texas 75265