



BiCMOS LOW-POWER CURRENT-MODE PWM CONTROLLER

FEATURES

- Enhanced Replacement for UC3842A Family With Pin-to-Pin Compatibility
- 1-MHz Operation
- 50- μ A Standby Current, 100- μ A Maximum
- Low Operating Current of 2.3 mA at 52 kHz
- Fast 35-ns Cycle-by-Cycle Overcurrent Limiting
- ± 1 -A Peak Output Current
- Rail-to-Rail Output Swings with 25-ns Rise and 20-ns Fall Times
- $\pm 1\%$ Initial Trimmed 2.5-V Error Amplifier Reference
- Trimmed Oscillator Discharge Current
- New Under Voltage Lockout Versions
- MSOP-8 Package Minimizes Board Space

APPLICATIONS

- Switch-Mode Power Supplies
- dc-to-dc Converters
- Board Mount Power Modules

DESCRIPTION

UCC38C4x family is a high-performance current-mode PWM controller. It is an enhanced BiCMOS version with pin-for-pin compatibility to the industry standard UC384xA family and UC384x family of PWM controllers. In addition, lower startup voltage versions of 7 V are offered as UCC38C40 and UCC38C41.

Providing necessary features to control fixed frequency, peak current-mode power supplies, this family offers the following performance advantages. The device offers high-frequency operation up to 1 MHz with low start-up and operating currents, thus minimizing start-up loss and low operating power consumption for improved efficiency. The device also features a very fast current-sense-to-output delay time of 35 ns and a ± 1 A peak output current capability with improved rise and fall times for driving large external MOSFETs directly.

The UCC38C4x family is offered in 8-pin packages, MSOP (DGK), SOIC (D) and PDIP (P).

FUNCTIONAL BLOCK DIAGRAM

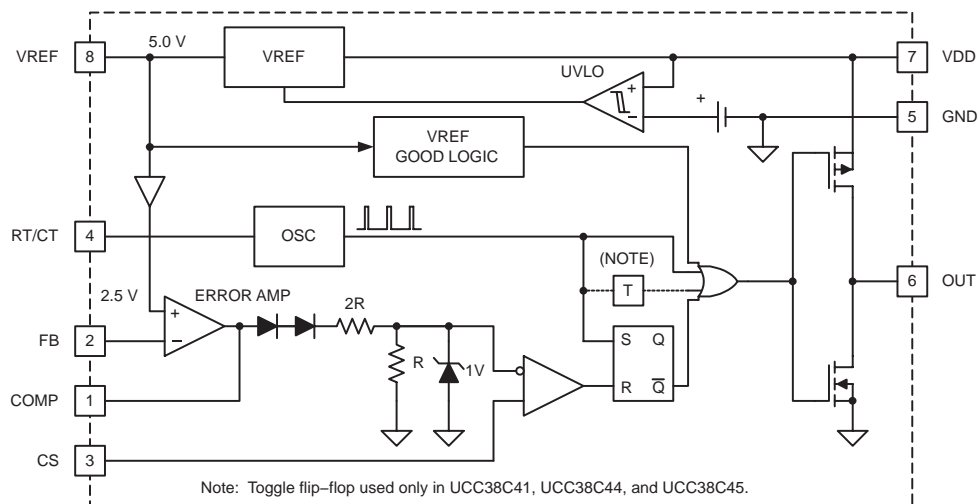

UDG-99139



Please be aware that an important notice concerning availability, standard warranty, and use in critical applications of Texas Instruments semiconductor products and disclaimers thereto appears at the end of this data sheet.

UCC28C40, UCC28C41, UCC28C42, UCC28C43, UCC28C44, UCC28C45 UCC38C40, UCC38C41, UCC38C42, UCC38C43, UCC38C44, UCC38C45

SLUS458C – AUGUST 2001 – REVISED SEPTEMBER 2003

recommended operating conditions

	MIN	MAX	UNIT
Input voltage, V_{DD}		18	V
Output voltage range, V_{OUT}		18	V
Average output current, $I_{OUT}^{\dagger\dagger}$		200	mA
Reference output current, $I_{OUT(ref)}^{\dagger\dagger}$		-20	mA
Operating junction temperature, $T_J^{\dagger\dagger}$	-55	150	°C

^{††} It is not recommended that the device operate under conditions beyond those specified in this table for extended periods of time.

absolute maximum ratings over operating free-air temperature (unless otherwise noted)^{†§}

Supply voltage (V_{DD})	20 V
(MAX ICC)	30 mA
Output current, I_{OUT} peak	±1 A
Output energy, capacitive load	5 μ J
Voltage rating (COMP, CS, FB)	-0.3 V to 6.3 V
(OUT)	-0.3 V to 20 V
(RT/CT)	-0.3 V to 6.3 V
(VREF)	7 V
Error amplifier output sink current	10 mA
Total Power Dissipation at $T_A = 25^\circ\text{C}$:	
D package ($\theta_{jc} = 22^\circ\text{C/W}$, $\theta_{ja} = 40 - 70^\circ\text{C/W}$)	650 mW
DGK package ($\theta_{jc} = 41^\circ\text{C/W}$, $\theta_{ja} = 238 - 269^\circ\text{C/W}$)	350 mW
P package ($\theta_{jc} = 50^\circ\text{C/W}$, $\theta_{ja} = 110^\circ\text{C/W}$)	850 mW
Operating junction temperature range, T_J	-55°C to 150°C
Storage temperature range T_{stg}	-65°C to 150°C
Lead Temperature (Soldering, 10 seconds)	300°C

[†] Stresses beyond those listed under “absolute maximum ratings” may cause permanent damage to the device. These are stress ratings only, and functional operation of the device at these or any other conditions beyond those indicated under “recommended operating conditions” is not implied. Exposure to absolute-maximum-rated conditions for extended periods may affect device reliability.

[§] All voltages are with respect to ground. Currents are positive into and negative out of the specified terminals. Consult the Packaging Section of the Databook for thermal limitations and considerations of the package.

AVAILABLE OPTIONS

T_A	MAXIMUM DUTY CYCLE	UVLO ON/OFF	SOIC-8 SMALL OUTLINE (D) [†]	PDIP-8 PLASTIC DIP (P)	MSOP-8 SMALL OUTLINE (DGK) [†]
-40°C to 105°C	100%	14.5V / 9.0V	UCC28C42D	UCC28C42P	UCC28C42DGK
		8.4V / 7.6V	UCC28C43D	UCC28C43P	UCC28C43DGK
		7.0V / 6.6V	UCC28C40D	UCC28C40P	UCC28C40DGK
	50%	14.5V / 9.0V	UCC28C44D	UCC28C44P	UCC28C44DGK
		8.4V / 7.6V	UCC28C45D	UCC28C45P	UCC28C45DGK
		7.0V / 6.6V	UCC28C41D	UCC28C41P	UCC28C41DGK
0°C to 70°C	100%	14.5V / 9.0V	UCC38C42D	UCC38C42P	UCC38C42DGK
		8.4V / 7.6V	UCC38C43D	UCC38C43P	UCC38C43DGK
		7.0V / 6.6V	UCC38C40D	UCC38C40P	UCC38C40DGK
	50%	14.5V / 9.0V	UCC38C44D	UCC38C44P	UCC38C44DGK
		8.4V / 7.6V	UCC38C45D	UCC38C45P	UCC38C45DGK
		7.0V / 6.6V	UCC38C41D	UCC38C41P	UCC38C41DGK

[†] D (SOIC-8) and DGK (MSOP-8) packages are available taped and reeled. Add R suffix to device type (e.g. UCC28C42DR) to order quantities of 2500 devices per reel. Tube quantities are 75 for D packages (SOIC-8) and 80 for DGK package (MSOP-8), and 50 for P package (PDIP-8).

UCC28C40, UCC28C41, UCC28C42, UCC28C43, UCC28C44, UCC28C45 UCC38C40, UCC38C41, UCC38C42, UCC38C43, UCC38C44, UCC38C45

SLUS458C – AUGUST 2001 – REVISED SEPTEMBER 2003

electrical characteristics $V_{DD} = 15\text{ V}$ (See Note 1), $R_T = 10\text{ k}\Omega$, $C_T = 3.3\text{ nF}$, $C_{VDD} = 0.1\mu\text{F}$ and no load on the outputs, $T_A = -40^\circ\text{C}$ to 105°C for the UCC28C4x and $T_A = 0^\circ\text{C}$ to 70°C for the UCC38C4x, $T_A = T_J$ (unless otherwise noted)

PARAMETER	TEST CONDITIONS	MIN	TYP	MAX	UNITS
Reference Section					
Output voltage, initial accuracy	$T_A = 25^\circ\text{C}$ $I_{OUT} = 1\text{ mA}$	4.9	5.0	5.1	V
Line regulation	$V_{DD} = 12\text{ V}$ to 18 V		0.2	20	mV
Load regulation	1mA to 20mA		3	25	mV
Temperature stability	See Note 2		0.2	0.4	mV/°C
Total output variation	See Note 2	4.82		5.18	V
Output noise voltage	10 Hz to 10 kHz, $T_A = 25^\circ\text{C}$, See Note 2		50		μV
Long term stability	1000 hours, $T_A = 125^\circ\text{C}$, See Note 2		5	25	mV
Output short circuit		-30	-45	-55	mA
Oscillator Section					
Initial accuracy	$T_A = 25^\circ\text{C}$, See Note 3	50.5	53	55	kHz
Voltage stability	$V_{DD} = 12\text{ V}$ to 18 V		0.2%	1.0%	
Temperature stability	T_{MIN} to T_{MAX} , See Note 2		1%	2.5%	
Amplitude	RT/CT Pin peak-to-peak		1.9		V
Discharge current	$T_A = 25^\circ\text{C}$, RT/CT = 2 V, See Note 4	7.7	8.4	9.0	mA
	RT/CT = 2 V, See Note 4	7.2	8.4	9.5	mA
Error Amplifier Section					
Feedback input voltage, initial accuracy	$V_{COMP} = 2.5\text{ V}$, $T_A = 25^\circ\text{C}$	2.475	2.500	2.525	V
Feedback input voltage, total variation	$V_{COMP} = 2.5\text{ V}$,	2.45	2.50	2.55	V
Input bias current	$V_{FB} = 5.0\text{ V}$		-0.1	-2.0	μA
Open-loop voltage gain (A_{VOL})	$V_{OUT} = 2\text{ V}$ to 4 V	65	90		dB
Unity gain bandwidth	See Note 2	1.0	1.5		MHz
Power supply rejection ratio (PSRR)	$V_{DD} = 12\text{ V}$ to 18 V	60			dB
Output sink current	$V_{FB} = 2.7\text{ V}$, $V_{COMP} = 1.1\text{ V}$	2	14		mA
Output source current	$V_{FB} = 2.3\text{ V}$, $V_{COMP} = 5\text{ V}$	-0.5	-1.0		mA
High-level output voltage (VOH)	$V_{FB} = 2.7\text{ V}$, $R_{LOAD} = 15\text{ k}$ to GND	5	6.8		V
Low-level output voltage (VOL)	$V_{FB} = 2.7\text{ V}$, $R_{LOAD} = 15\text{ k}$ to VREF		0.1	1.1	V
Current Sense Section					
Gain	See Note 5, 6	2.85	3.00	3.15	V/V
Maximum input signal	$V_{FB} < 2.4\text{ V}$	0.9	1.0	1.1	V
Power supply rejection ratio (PSRR)	$V_{DD} = 12\text{ V}$ to 18 V , See Note 2, 5		70		dB
Input bias current			-0.1	-2.0	μA
CS to output delay			35	70	ns
COMP to CS offset	$V_{CS} = 0\text{ V}$		1.15		V

NOTE: 1. Adjust V_{DD} above the start threshold before setting at 15 V.

NOTE: 2. Ensured by design. Not production tested.

NOTE: 3. Output frequencies of the UCC38C41, UCC38C44 and the UCC38C45 are half the oscillator frequency.

NOTE: 4. Oscillator discharge current is measured with $R_T = 10\text{ k}\Omega$ to V_{REF} .

NOTE: 5. Parameter measured at trip point of latch with $V_{FB} = 0\text{ V}$.

NOTE: 6. Gain is defined as $ACS = \frac{\Delta V_{COM}}{\Delta V_{CS}}$, $0\text{ V} \leq V_{CS} \leq 900\text{ mV}$

UCC28C40, UCC28C41, UCC28C42, UCC28C43, UCC28C44, UCC28C45 UCC38C40, UCC38C41, UCC38C42, UCC38C43, UCC38C44, UCC38C45

SLUS458C – AUGUST 2001 – REVISED SEPTEMBER 2003

electrical characteristics $V_{DD} = 15\text{ V}$ (See Note 1), $R_T = 10\text{ k}\Omega$, $C_T = 3.3\text{ nF}$, $C_{VDD} = 0.1\text{ }\mu\text{F}$ and no load on the outputs, $T_A = -40^\circ\text{C}$ to 105°C for the UCC28C4x and $T_A = 0^\circ\text{C}$ to 70°C for the UCC38C4x, $T_A = T_J$ (unless otherwise noted)

PARAMETER	TEST CONDITIONS	MIN	TYP	MAX	UNITS
Output Section					
$V_{OUT\text{ low}}$ ($R_{DS(on)}$ pull-down)	$I_{SINK} = 200\text{ mA}$		5.5	15	Ω
$V_{OUT\text{ high}}$ ($R_{DS(on)}$ pull-up)	$I_{SOURCE} = 200\text{ mA}$		10	25	
Rise time	$T_A = 25^\circ\text{C}$, $C_{LOAD} = 1\text{ nF}$		25	50	ns
Fall time	$T_A = 25^\circ\text{C}$, $C_{LOAD} = 1\text{ nF}$		20	40	
Undervoltage Lockout Section					
Start threshold	UCC38C42, UCC38C44	13.5	14.5	15.5	V
	UCC38C43, UCC38C45	7.8	8.4	9.0	
	UCC38C40, UCC38C41	6.5	7.0	7.5	
Minimum operating voltage	UCC38C42, UCC38C44	8	9	10	
	UCC38C43, UCC38C45	7.0	7.6	8.2	
	UCC38C40, UCC38C41	6.1	6.6	7.1	
PWM Section					
Maximum duty cycle	UCC38C42, UCC38C43, UCC38C40, $V_{FB} < 2.4\text{ V}$	94%	96%		
	UCC38C44, UCC38C45, UCC38C41, $V_{FB} < 2.4\text{ V}$	47%	48%		
Minimum duty cycle	$V_{FB} > 2.6\text{ V}$			0%	
Current Supply Section					
Start-up current ($I_{START-UP}$)	$V_{DD} = \text{Undervoltage lockout start threshold } (-0.5\text{ V})$		50	100	μA
Operating supply current (I_{DD})	$V_{FB} = V_{CS} = 0\text{ V}$		2.3	3.0	mA

NOTE 1: Adjust V_{DD} above the start threshold before setting at 15 V.

PDIP (P) or SOIC (D) PACKAGE
(TOP VIEW)

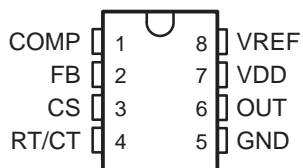

MSOP (DGK) PACKAGE
(TOP VIEW)

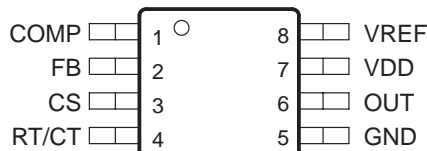

pin assignments

COMP: This pin provides the output of the error amplifier for compensation. In addition, the COMP pin is frequently used as a control port by utilizing a secondary-side error amplifier to send an error signal across the secondary-primary isolation boundary through an opto-isolator.

CS: The current sense pin is the non-inverting input to the PWM comparator. This is compared to a signal proportional to the error amplifier output voltage. A voltage ramp can be applied to this pin to run the device with a voltage mode control configuration.

FB: This pin is the inverting input to the error amplifier. The non-inverting input to the error amplifier is internally trimmed to $2.5\text{ V} \pm 1\%$.

GND: Ground return pin for the output driver stage and the logic level controller section.

OUT: The output of the on-chip drive stage. OUT is intended to directly drive a MOSFET. The OUT pin in the UCC38C40, UCC38C42 and UCC38C43 is the same frequency as the oscillator, and can operate near 100% duty cycle. In the UCC38C41, UCC38C44 and the UCC38C45, the frequency of OUT is one-half that of the oscillator due to an internal T flipflop. This limits the maximum duty cycle to $< 50\%$.

RT/CT: Timing resistor and timing capacitor. The timing capacitor should be connected to the device ground using minimal trace length.

VDD: Power supply pin for the device. This pin should be bypassed with a $0.1\text{-}\mu\text{F}$ capacitor with minimal trace lengths. Additional capacitance may be needed to provide hold up power to the device during startup.

VREF: 5-V reference. For stability, the reference should be bypassed with a $0.1\text{-}\mu\text{F}$ capacitor to ground using the minimal trace length possible.

APPLICATION INFORMATION

This device is a pin-for-pin replacement of the bipolar UC3842 family of controllers, the industry standard PWM controller for single-ended converters. Familiarity with this controller family is assumed.

The UCC28C4x/UCC38C4x series is an enhanced replacement with pin-to-pin compatibility to the bipolar UC284x/UC384x and UC284xA/UC384xA families. The new series offers improved performance when compared to older bipolar devices and other competitive BiCMOS devices with similar functionality. Note that these improvements discussed below generally consist of tighter specification limits that are a subset of the older product ratings, maintaining drop-in capability. In new designs these improvements can be utilized to reduce the component count or enhance circuit performance when compared to the previously available devices.

advantages

This device increases the total circuit efficiency whether operating off-line or in dc input circuits. In off-line applications the low start-up current of this device reduces steady state power dissipation in the startup resistor, and the low operating current maximizes efficiency while running. The low running current also provides an efficiency boost in battery operated supplies.

low voltage operation

Two members of the UCC38C4x family are intended for applications that require a lower start-up voltage than the original family members. The UCC38C40 and UCC38C41 have a turn-on voltage of 7.0 V typical and exhibit hysteresis of 0.4 V for a turn-off voltage of 6.6 V. This reduced start-up voltage enables use in systems with lower voltages, such as 12-V battery systems which are nearly discharged.

high speed operation

The BiCMOS design allows operation at high frequencies that were not feasible in the predecessor bipolar devices. First, the output stage has been redesigned to drive the external power switch in approximately half the time of the earlier devices. Second, the internal oscillator is more robust with less variation as frequency increases. In addition, the current sense to output delay has been reduced by a factor of three, to 45ns typical. These features combine to provide a device capable of reliable high frequency operation.

The UCC38C4x family oscillator is true to the curves of the original bipolar devices at lower frequencies yet extends the frequency programmability range to at least 1MHz. This allows the device to offer pin to pin capability where required yet capable of extending the operational range to the higher frequencies typical of latest applications. When the original UC3842 was released in 1984 most switching supplies operated between 20kHz and 100kHz. Today, the UCC38C4x can be used in designs cover a span roughly ten times higher than those numbers.

start/run current improvements

The start-up current is only 60 μ A typical, a significant reduction from the bipolar device's ratings of 300 μ A (UC384xA). For operation over the temperature range of -40 to 85° C the UCC28C4x devices offer a maximum startup current of 100 μ A, an improvement over competitive BiCMOS devices. This allows the power supply designer to further optimize the selection of the startup resistor value to provide a more efficient design. In applications where low component cost overrides maximum efficiency the low run current of 2.3 mA, typical, may allow the control device to run directly through the single resistor to (+) rail, rather than needing a bootstrap winding on the power transformer, along with a rectifier. The start/run resistor for this case must also pass enough current to allow driving the primary switching MOSFET, which may be a few milliamps in small devices.

APPLICATION INFORMATION

± 1% initial reference voltage

The BiCMOS internal reference of 2.5 V has an enhanced design and utilizes production trim to allow initial accuracy of ±1% at room temperature and ± 2% over the full temperature range. This can be used to eliminate an external reference in applications that do not require the extreme accuracy afforded by the additional device. This is very useful for nonisolated dc-to-dc applications where the control device is referenced to the same common as the output. It is also applicable in offline designs that regulate on the primary side of the isolation boundary by looking at a primary bias winding, or perhaps from a winding on the output inductor of a buck-derived circuit.

reduced discharge current variation

The original UC3842 oscillator did not have trimmed discharged current, and the parameter was not specified on the datasheet. Since many customers attempted to use the discharge current to set a crude deadtime limit the UC3842A family was released with a trimmed discharge current specified at 25°C. The UCC28C4x/UCC38C4x series now offers even tighter control of this parameter, with approximately ±3% accuracy at 25°C, and less than 10% variation over temperature using the UCC28C4x devices. This level of accuracy can enable a meaningful limit to be programmed, a feature not currently seen in competitive BiCMOS devices. The improved oscillator and reference also contribute to decreased variation in the peak to peak variation in the oscillator waveform, which is often used as the basis for slope compensation for the complete power system.

soft-start

The following diagram provides a typical soft-start circuit for use with the UCC38C42. The values of R and C should be selected to bring the COMP pin up at a controlled rate, limiting the peak current supplied by the power stage. After the soft-start interval is complete the capacitor continues to charge to V_{REF} , effectively removing the PNP transistor from circuit considerations.

The optional diode in parallel with the resistor forces a soft-start each time the PWM goes through UVLO and the reference (V_{REF}) goes low. Without the diode, the capacitor otherwise remains charged during a brief loss of supply or brown-out, and no soft-start is enabled upon reapplication of V_{IN} .

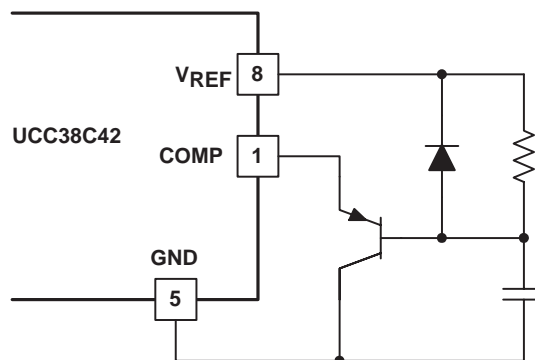

Figure 1

UDG-01072

APPLICATION INFORMATION

oscillator synchronization

The UCC38C4x oscillator has the same synchronization characteristics as the original bipolar devices. Thus, the information in the Application Note U-100A, *UC3842/3/4/5 Provides Low-Cost Current-Mode Control*, (TI Literature No. SLUA143) still applies. The application note describes how a small resistor from the timing capacitor-to-ground can offer an insertion point for synchronization to an external clock, (see Figures 2 and 3). Figure 2 shows how the UCC38C42 can be synchronized to an external clock source. This allows precise control of frequency and dead time with a digital pulse train.

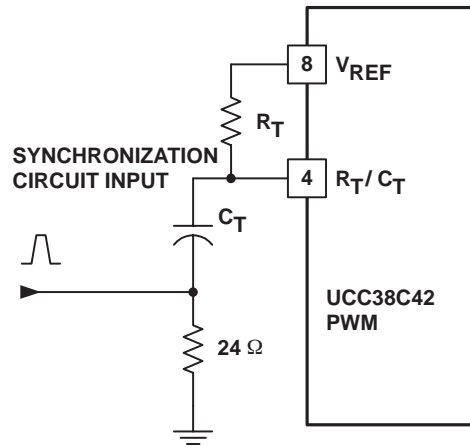

UDG-01069

Figure 2. Oscillator Synchronization Circuit

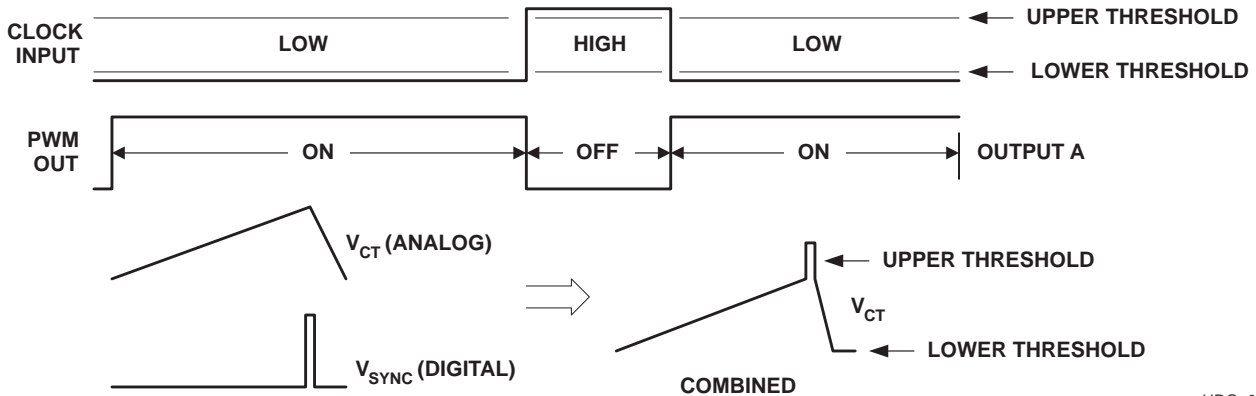

UDG-01070

Figure 3. Synchronization to an External Clock

APPLICATION INFORMATION

precautions

The absolute maximum supply voltage is 20 V, including any transients that may be present. If this voltage is exceeded, device damage is likely. This is in contrast to the predecessor bipolar devices, which could survive up to 30 V. Thus, the supply pin should be decoupled as close to the ground pin as possible. Also, since no clamp is included in the device, the supply pin should be protected from external sources which could exceed the 20 V level.

Careful layout of the printed board has always been a necessity for high frequency power supplies. As the device switching speeds and operating frequencies increase the layout of the converter becomes increasingly important.

This 8-pin device has only a single ground for the logic and power connections. This forces the gate drive current pulses to flow through the same ground that the control circuit uses for reference. Thus, the interconnect inductance should be minimized as much as possible. One implication is to place the device (gate driver) circuitry close to the MOSFET it is driving. Note that this can conflict with the need for the error amplifier and the feedback path to be away from the noise generating components.

circuit applications

Figure 4 shows a typical off-line application.

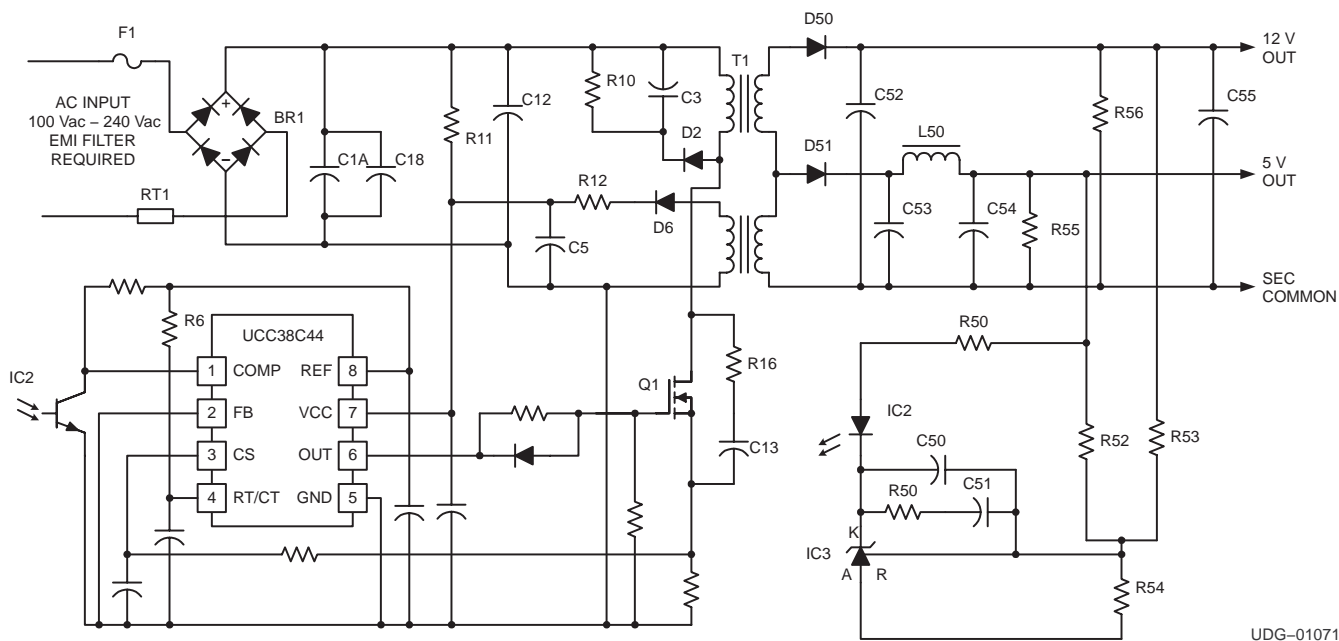

UDG-01071

Figure 4. Typical Off-Line Application

Figure 5 shows the forward converter with synchronous rectification. This application provides 48 V to 3.3 V at 10 A with over 85% efficiency and uses the UCC38C42 as the secondary-side controller and UCC3961 as the primary-side startup control device.

APPLICATION INFORMATION

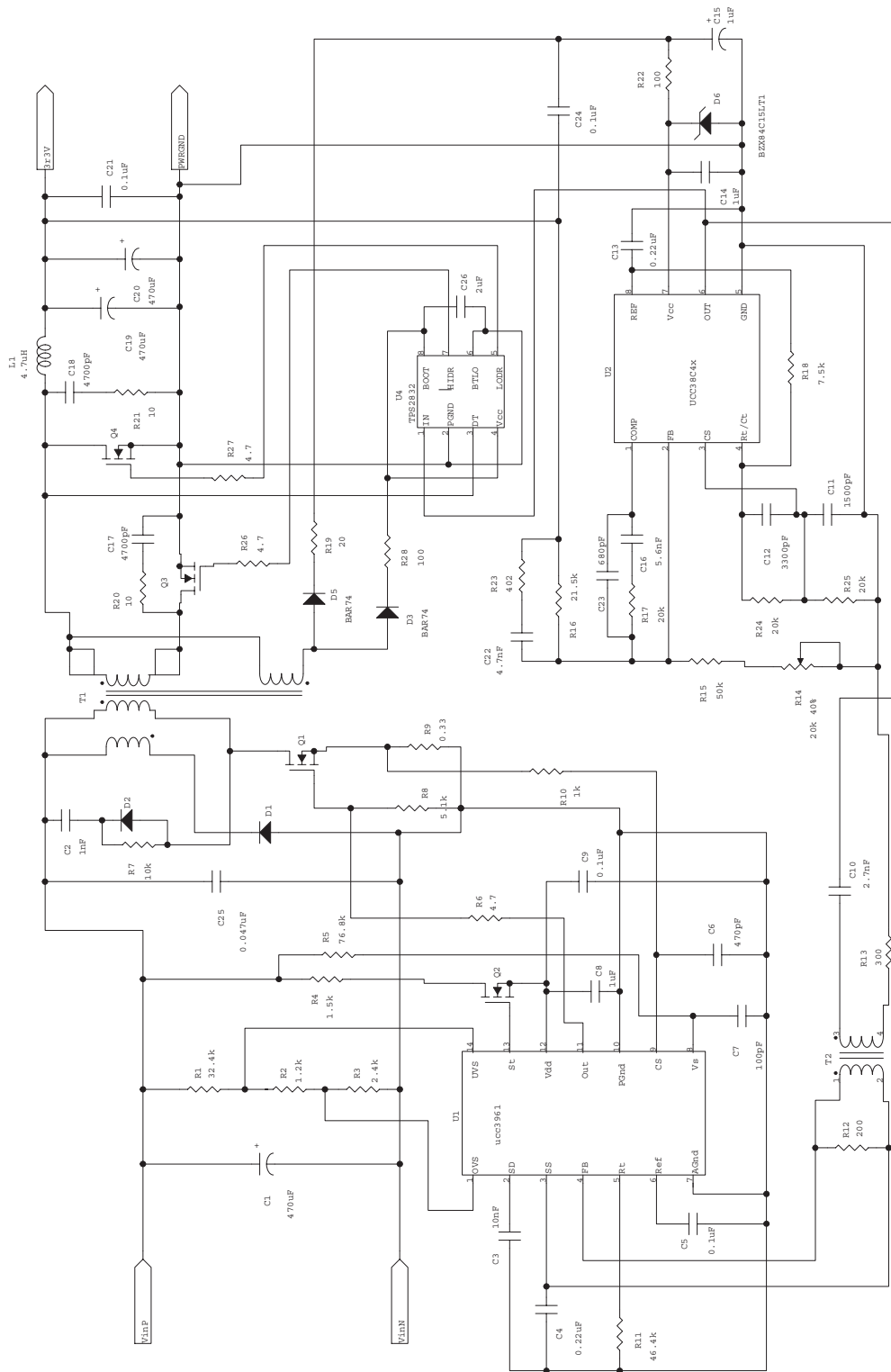

Figure 5. Forward Converter with Synchronous Rectification Using the UCC38C42 as the Secondary-Side Controller

TYPICAL CHARACTERISTICS

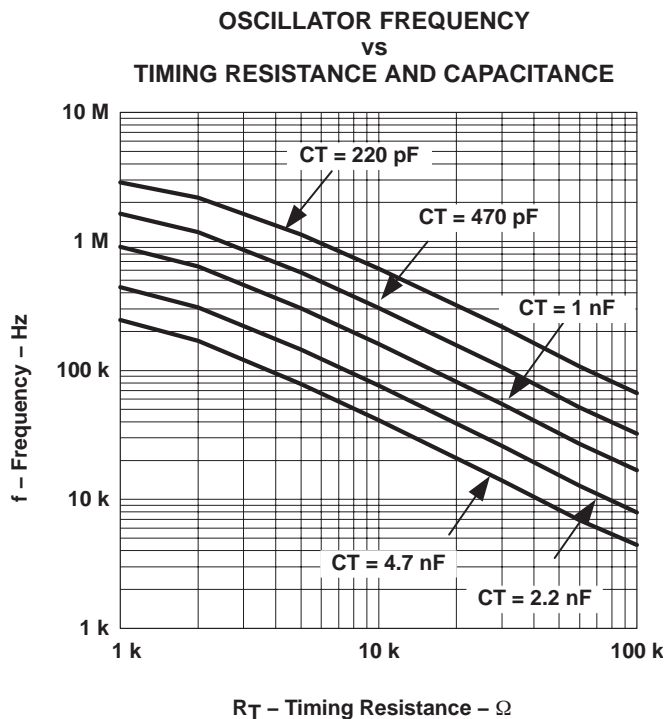

Figure 6

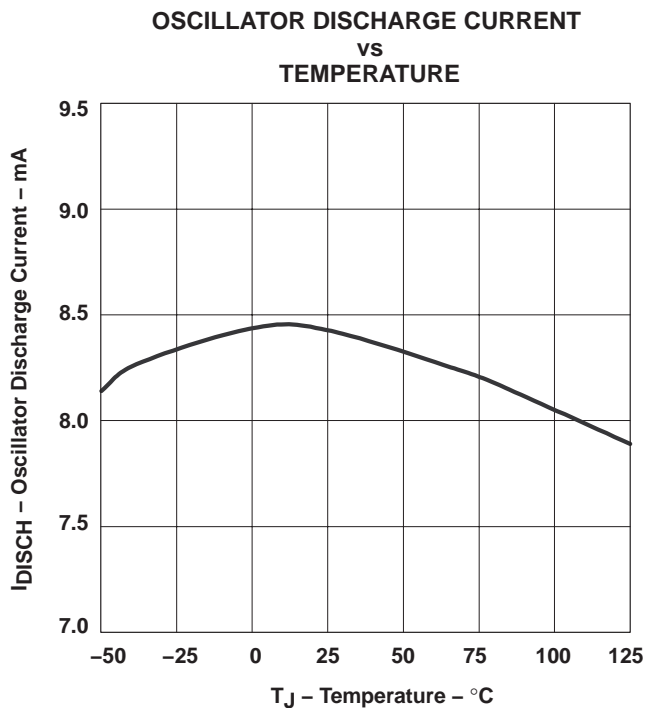

Figure 7

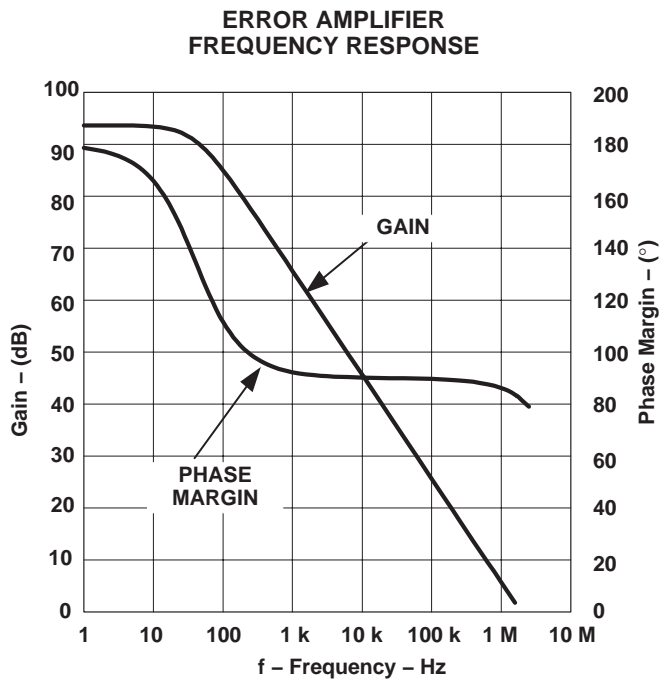

Figure 8

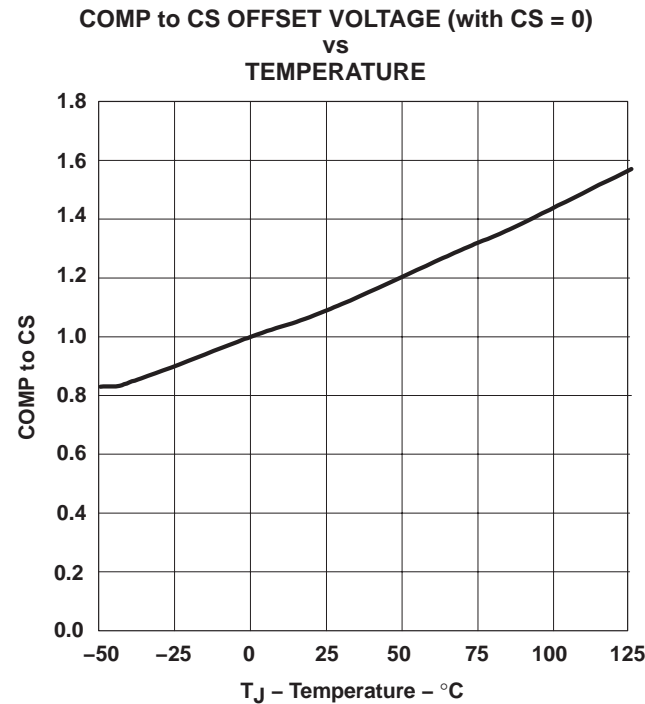

Figure 9

TYPICAL CHARACTERISTICS

**REFERENCE VOLTAGE
vs
TEMPERATURE**

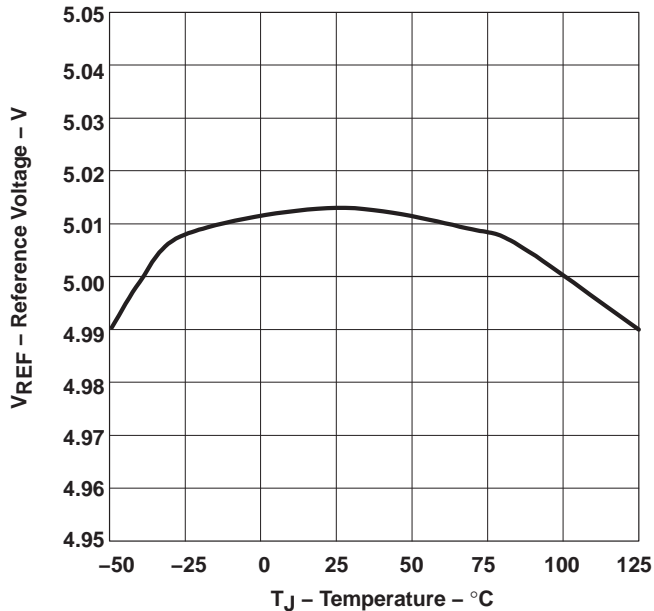

Figure 10

**ERROR AMPLIFIER REFERENCE VOLTAGE
vs
TEMPERATURE**

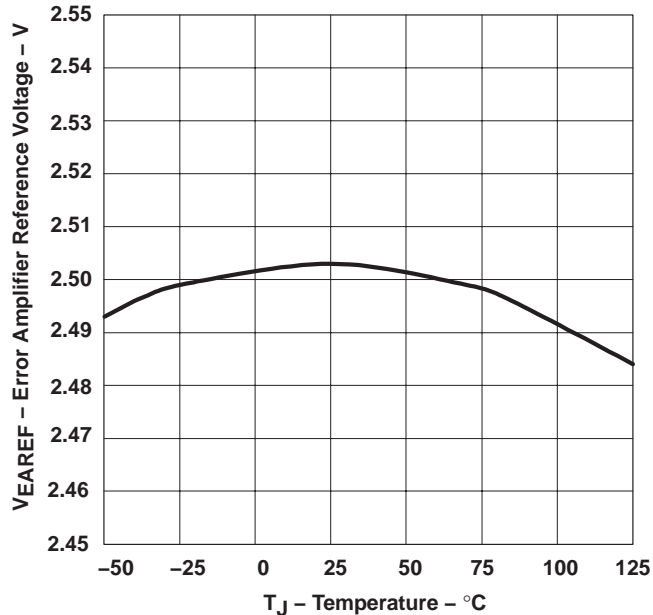

Figure 11

**REFERENCE SHORT-CIRCUIT CURRENT
vs
TEMPERATURE**

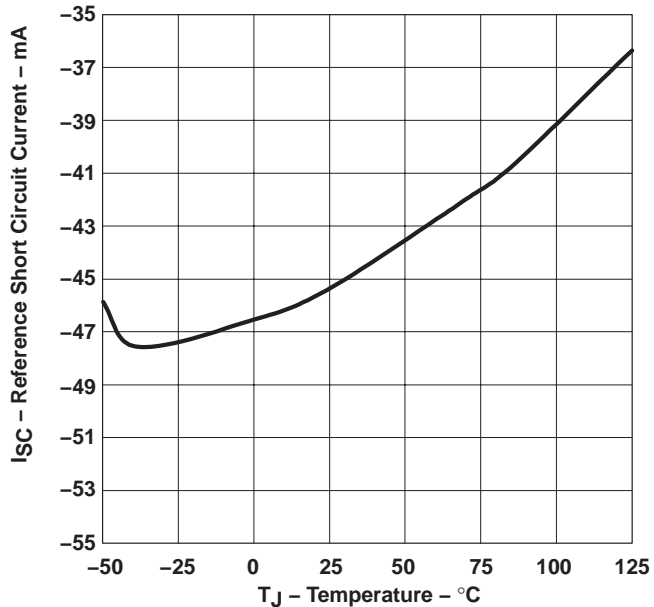

Figure 12

**ERROR AMPLIFIER INPUT BIAS CURRENT
vs
TEMPERATURE**

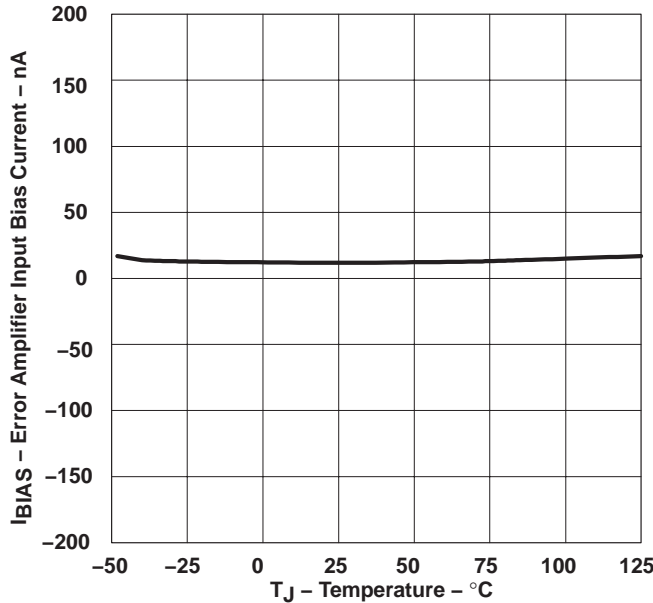

Figure 13

TYPICAL CHARACTERISTICS

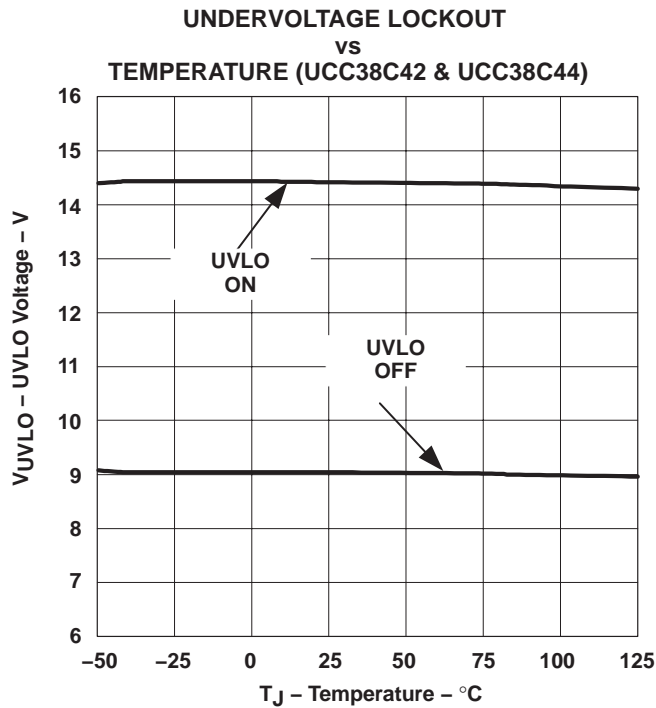

Figure 14

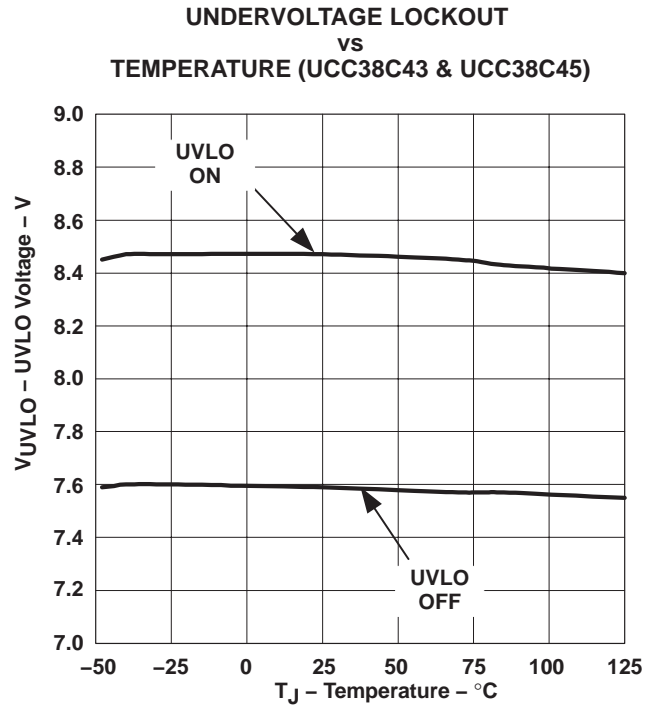

Figure 15

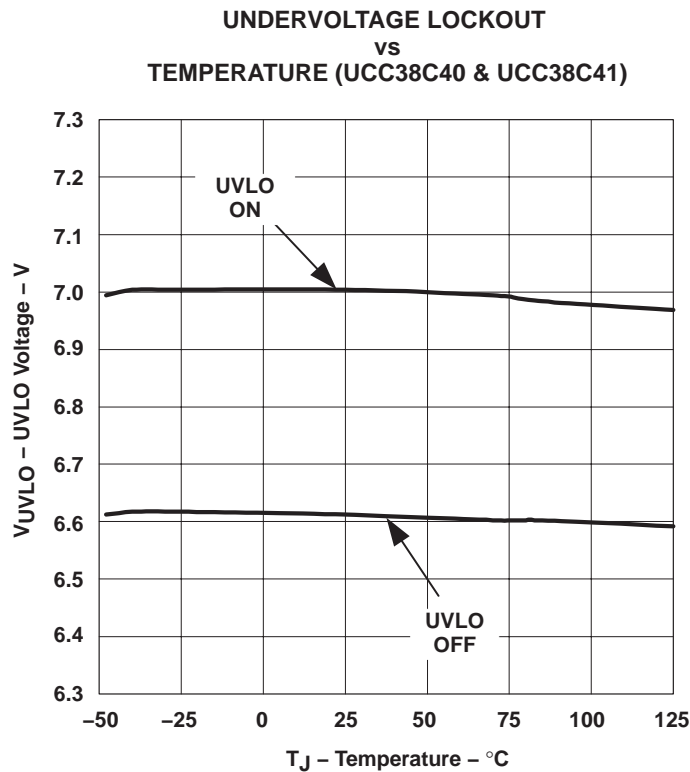

Figure 16

TYPICAL CHARACTERISTICS

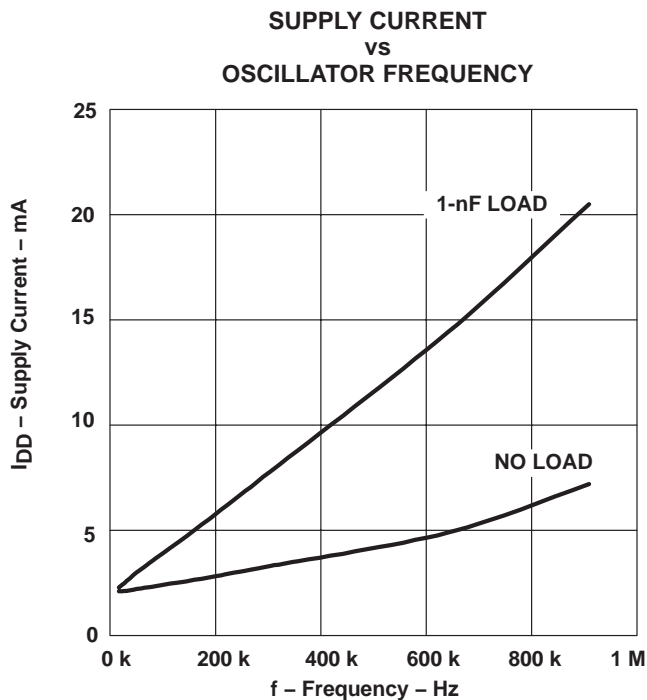

Figure 17

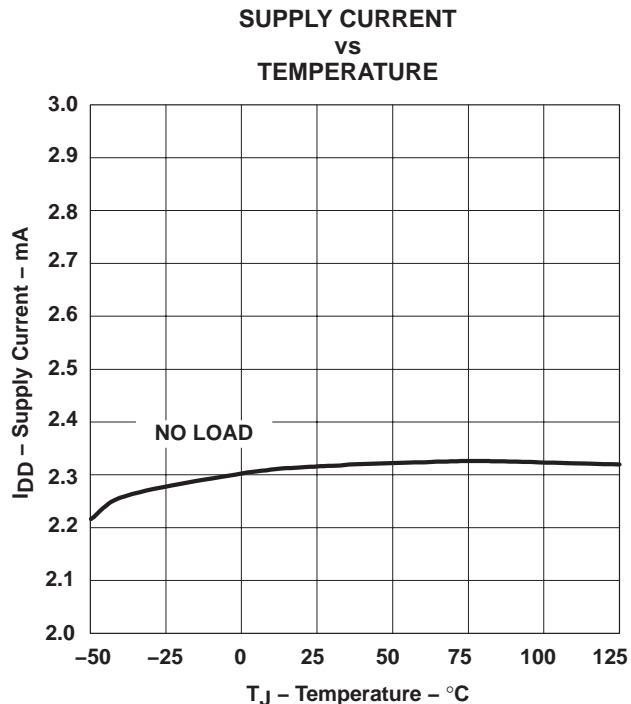

Figure 18

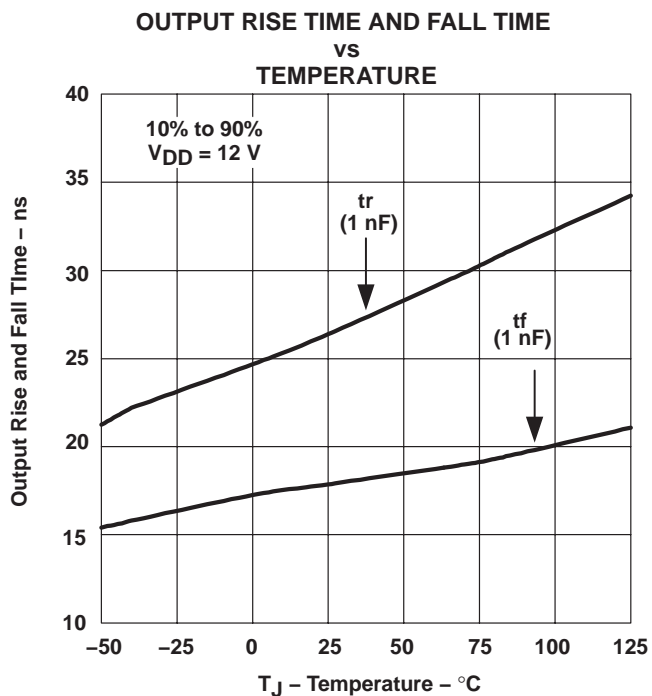

Figure 19

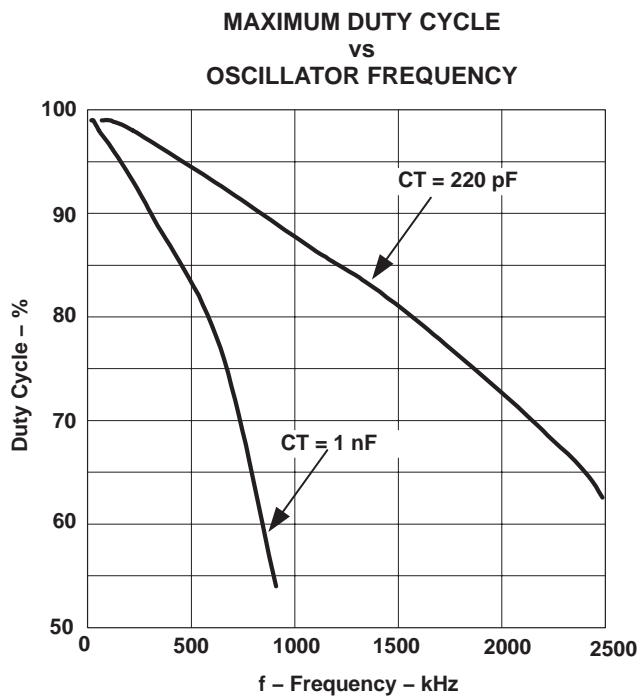

Figure 20

TYPICAL CHARACTERISTICS

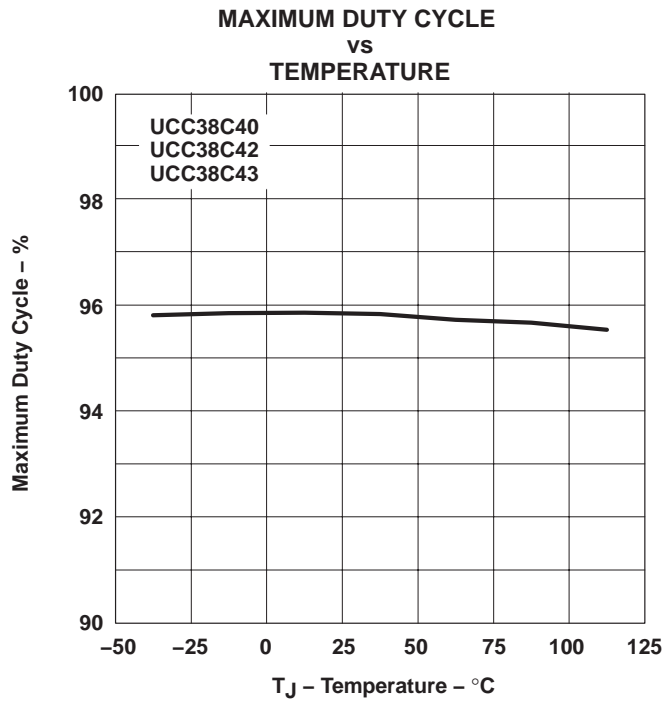

Figure 21

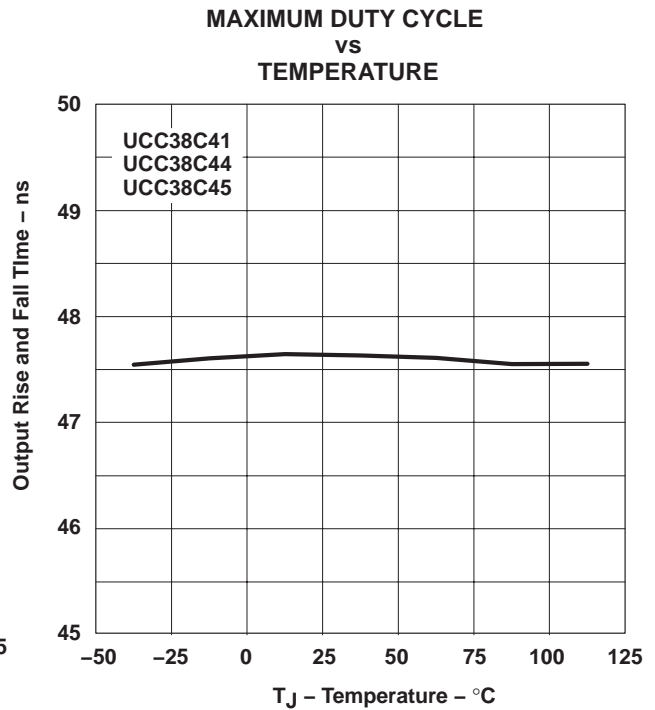

Figure 22

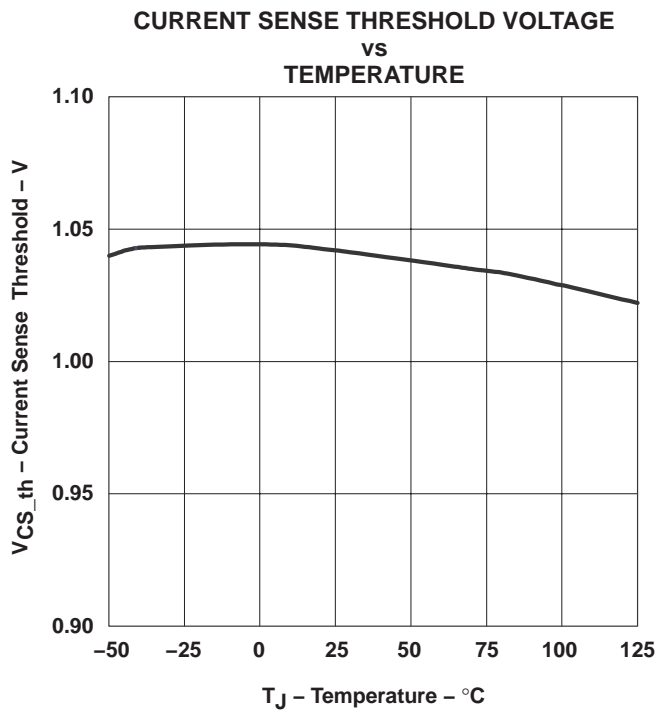

Figure 23

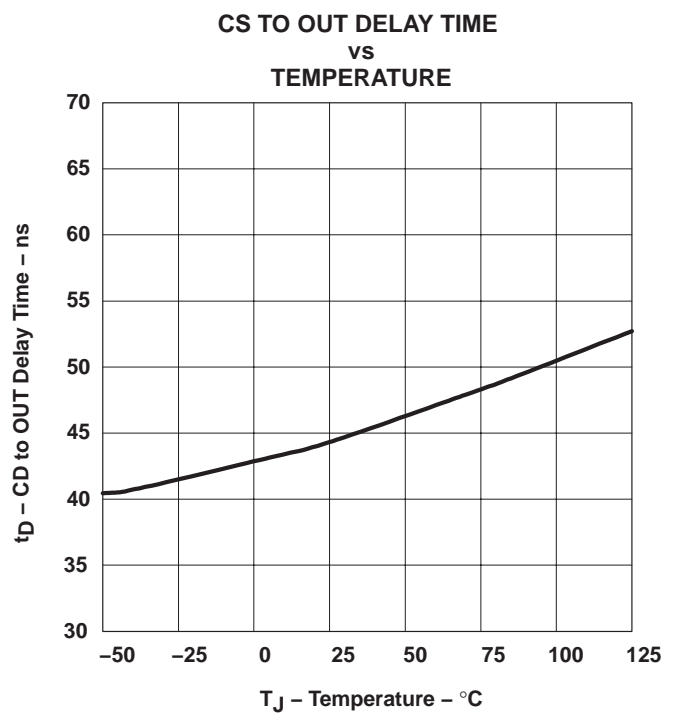

Figure 24

UCC28C40, UCC28C41, UCC28C42, UCC28C43, UCC28C44, UCC28C45
UCC38C40, UCC38C41, UCC38C42, UCC38C43, UCC38C44, UCC38C45

SLUS458C – AUGUST 2001 – REVISED SEPTEMBER 2003

MECHANICAL DATA

D (SOIC)

PLASTIC SMALL-OUTLINE PACKAGE

Note: UCC38C4x is offered in an 8-pin package ONLY.

14 PINS SHOWN

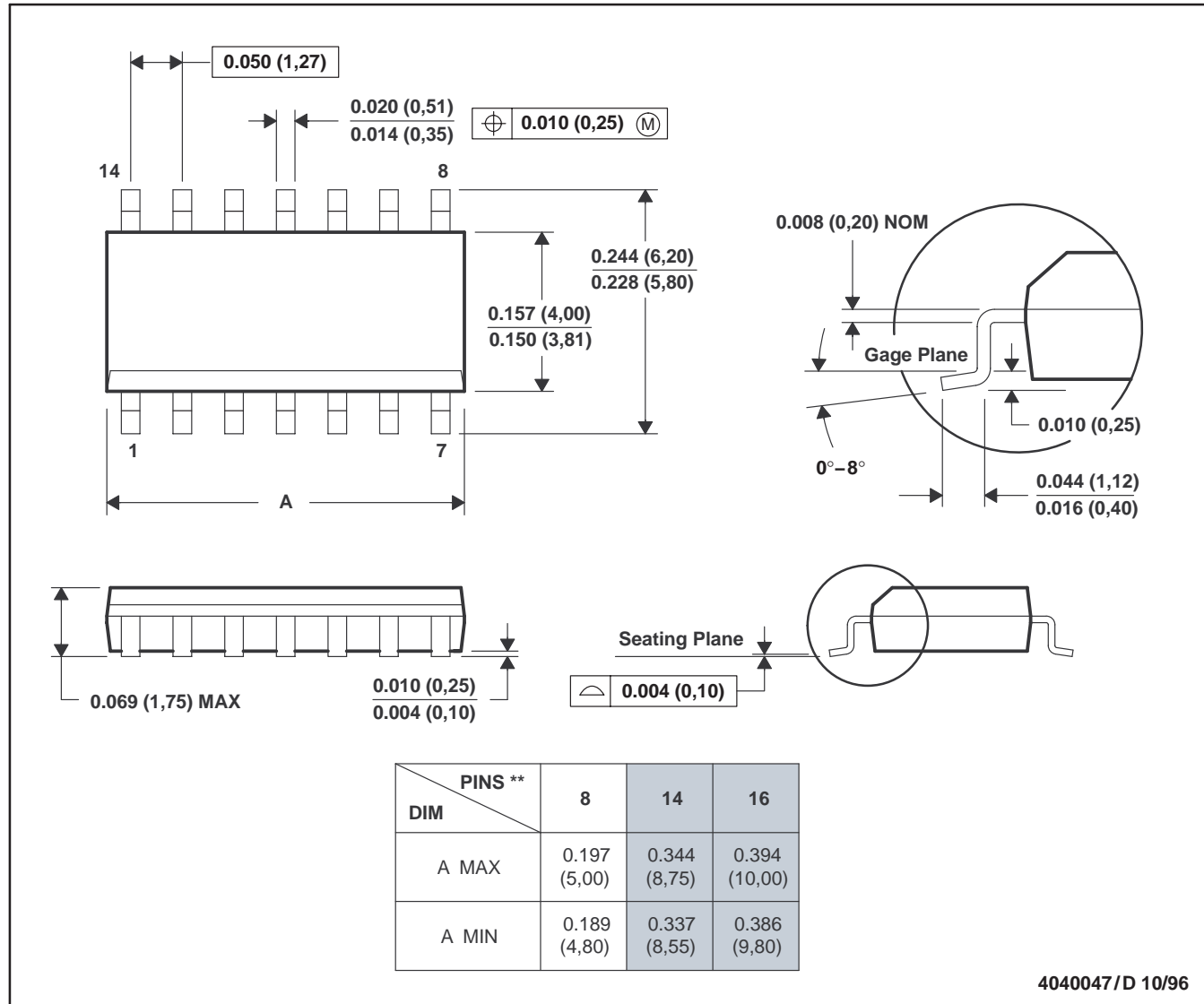

- NOTES: A. All linear dimensions are in inches (millimeters).
 B. This drawing is subject to change without notice.
 C. Body dimensions do not include mold flash or protrusion, not to exceed 0.006 (0,15).
 D. Falls within JEDEC MS-012

MECHANICAL DATA

DGK (R-PDSO-G8)

PLASTIC SMALL-OUTLINE PACKAGE

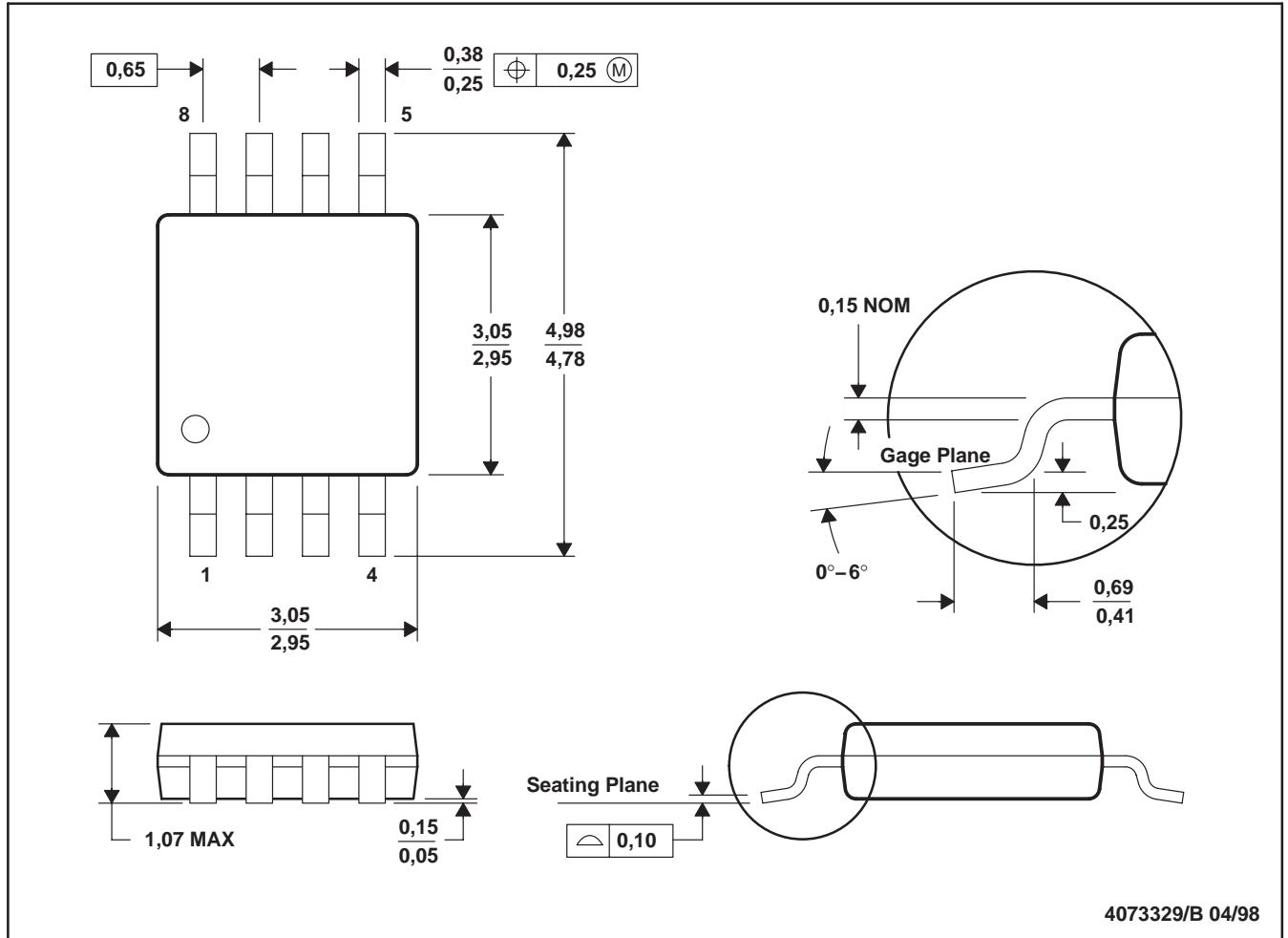

- NOTES: A. All linear dimensions are in millimeters.
 B. This drawing is subject to change without notice.
 C. Body dimensions do not include mold flash or protrusion.
 D. Falls within JEDEC MO-187

UCC28C40, UCC28C41, UCC28C42, UCC28C43, UCC28C44, UCC28C45
UCC38C40, UCC38C41, UCC38C42, UCC38C43, UCC38C44, UCC38C45

SLUS458C – AUGUST 2001 – REVISED SEPTEMBER 2003

MECHANICAL DATA

P (PDIP)

PLASTIC DUAL-IN-LINE

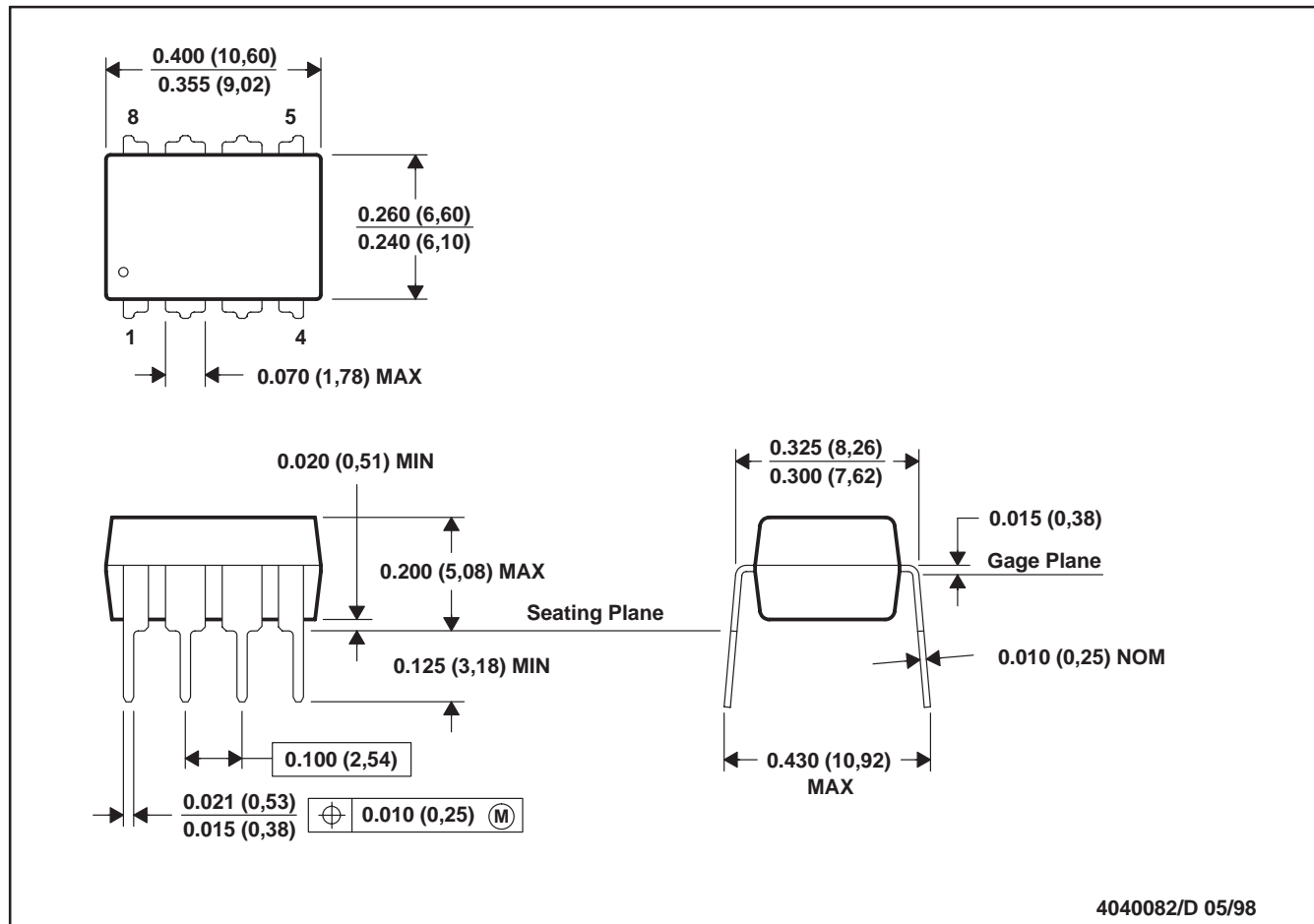

- NOTES: A. All linear dimensions are in inches (millimeters).
 B. This drawing is subject to change without notice.
 C. Falls within JEDEC MS-001

PACKAGING INFORMATION

Orderable Device	Status ⁽¹⁾	Package Type	Package Drawing	Pins	Package Qty	Eco Plan ⁽²⁾	Lead/Ball Finish	MSL Peak Temp ⁽³⁾
UCC28C40D	ACTIVE	SOIC	D	8	75	None	CU NIPDAU	Level-1-220C-UNLIM
UCC28C40DGK	ACTIVE	MSOP	DGK	8	100	None	CU NIPDAU	Level-1-220C-UNLIM
UCC28C40DGKR	ACTIVE	MSOP	DGK	8	2500	None	CU NIPDAU	Level-1-220C-UNLIM
UCC28C40DR	ACTIVE	SOIC	D	8	2500	None	CU NIPDAU	Level-1-220C-UNLIM
UCC28C40P	ACTIVE	PDIP	P	8	50	Pb-Free (RoHS)	CU NIPDAU	Level-NC-NC-NC
UCC28C41D	ACTIVE	SOIC	D	8	75	None	CU NIPDAU	Level-1-220C-UNLIM
UCC28C41DGK	ACTIVE	MSOP	DGK	8	100	None	CU NIPDAU	Level-1-220C-UNLIM
UCC28C41DGKR	ACTIVE	MSOP	DGK	8	2500	None	CU NIPDAU	Level-1-220C-UNLIM
UCC28C41DR	ACTIVE	SOIC	D	8	2500	None	CU NIPDAU	Level-1-220C-UNLIM
UCC28C41P	ACTIVE	PDIP	P	8	50	Pb-Free (RoHS)	CU NIPDAU	Level-NC-NC-NC
UCC28C42D	ACTIVE	SOIC	D	8	75	None	CU NIPDAU	Level-1-220C-UNLIM
UCC28C42DGK	ACTIVE	MSOP	DGK	8	100	None	CU SNPB	Level-1-220C-UNLIM
UCC28C42DGKR	ACTIVE	MSOP	DGK	8	2500	None	CU SNPB	Level-1-220C-UNLIM
UCC28C42DR	ACTIVE	SOIC	D	8	2500	None	CU NIPDAU	Level-1-220C-UNLIM
UCC28C42P	ACTIVE	PDIP	P	8	50	Pb-Free (RoHS)	CU NIPDAU	Level-NC-NC-NC
UCC28C43D	ACTIVE	SOIC	D	8	75	None	CU NIPDAU	Level-1-220C-UNLIM
UCC28C43DGK	ACTIVE	MSOP	DGK	8	100	None	CU NIPDAU	Level-1-220C-UNLIM
UCC28C43DGKR	ACTIVE	MSOP	DGK	8	2500	None	CU NIPDAU	Level-1-220C-UNLIM
UCC28C43DR	ACTIVE	SOIC	D	8	2500	None	CU NIPDAU	Level-1-220C-UNLIM
UCC28C43P	ACTIVE	PDIP	P	8	50	Pb-Free (RoHS)	CU NIPDAU	Level-NC-NC-NC
UCC28C44D	ACTIVE	SOIC	D	8	75	None	CU NIPDAU	Level-1-220C-UNLIM
UCC28C44DGK	ACTIVE	MSOP	DGK	8	100	None	CU SNPB	Level-1-220C-UNLIM
UCC28C44DGKR	ACTIVE	MSOP	DGK	8	2500	None	CU SNPB	Level-1-220C-UNLIM
UCC28C44DR	ACTIVE	SOIC	D	8	2500	None	CU NIPDAU	Level-1-220C-UNLIM
UCC28C44P	ACTIVE	PDIP	P	8	50	Pb-Free (RoHS)	CU NIPDAU	Level-NC-NC-NC
UCC28C45D	ACTIVE	SOIC	D	8	75	None	CU NIPDAU	Level-1-220C-UNLIM
UCC28C45DGK	ACTIVE	MSOP	DGK	8	100	None	CU SNPB	Level-1-220C-UNLIM
UCC28C45DGKR	ACTIVE	MSOP	DGK	8	2500	None	CU SNPB	Level-1-220C-UNLIM
UCC28C45DGKRG4	ACTIVE	MSOP	DGK	8	2500	Green (RoHS & no Sb/Br)	CU NIPDAU	Level-1-260C-UNLIM
UCC28C45DR	ACTIVE	SOIC	D	8	2500	None	CU NIPDAU	Level-1-220C-UNLIM
UCC28C45DRG4	ACTIVE	SOIC	D	8	2500	Green (RoHS & no Sb/Br)	CU NIPDAU	Level-2-260C-1 YEAR
UCC28C45P	ACTIVE	PDIP	P	8	50	Pb-Free (RoHS)	CU NIPDAU	Level-NC-NC-NC
UCC38C40D	ACTIVE	SOIC	D	8	75	None	CU NIPDAU	Level-1-220C-UNLIM
UCC38C40DGK	ACTIVE	MSOP	DGK	8	100	None	CU NIPDAU	Level-1-220C-UNLIM
UCC38C40DGKR	ACTIVE	MSOP	DGK	8	2500	None	CU NIPDAU	Level-1-220C-UNLIM
UCC38C40DR	ACTIVE	SOIC	D	8	2500	None	CU NIPDAU	Level-1-220C-UNLIM

Orderable Device	Status ⁽¹⁾	Package Type	Package Drawing	Pins	Package Qty	Eco Plan ⁽²⁾	Lead/Ball Finish	MSL Peak Temp ⁽³⁾
UCC38C40P	ACTIVE	PDIP	P	8	50	Pb-Free (RoHS)	CU NIPDAU	Level-NC-NC-NC
UCC38C41D	ACTIVE	SOIC	D	8	50	None	CU NIPDAU	Level-1-220C-UNLIM
UCC38C41DGK	ACTIVE	MSOP	DGK	8	100	None	CU NIPDAU	Level-1-220C-UNLIM
UCC38C41DGKR	ACTIVE	MSOP	DGK	8	2500	None	CU NIPDAU	Level-1-220C-UNLIM
UCC38C41DR	ACTIVE	SOIC	D	8	2500	None	CU NIPDAU	Level-1-220C-UNLIM
UCC38C41P	ACTIVE	PDIP	P	8	50	Pb-Free (RoHS)	CU NIPDAU	Level-NC-NC-NC
UCC38C41PG4	ACTIVE	PDIP	P	8	50	None	Call TI	Call TI
UCC38C42D	ACTIVE	SOIC	D	8	75	None	CU NIPDAU	Level-1-220C-UNLIM
UCC38C42DGK	ACTIVE	MSOP	DGK	8	100	None	CU SNPB	Level-1-220C-UNLIM
UCC38C42DGKR	ACTIVE	MSOP	DGK	8	2500	None	CU SNPB	Level-1-220C-UNLIM
UCC38C42DR	ACTIVE	SOIC	D	8	2500	None	CU NIPDAU	Level-1-220C-UNLIM
UCC38C42P	ACTIVE	PDIP	P	8	50	Pb-Free (RoHS)	CU NIPDAU	Level-NC-NC-NC
UCC38C43D	ACTIVE	SOIC	D	8	75	None	CU NIPDAU	Level-1-220C-UNLIM
UCC38C43DGK	ACTIVE	MSOP	DGK	8	100	None	Call TI	Level-1-220C-UNLIM
UCC38C43DGKR	ACTIVE	MSOP	DGK	8	2500	None	Call TI	Level-1-220C-UNLIM
UCC38C43DR	ACTIVE	SOIC	D	8	2500	None	CU NIPDAU	Level-1-220C-UNLIM
UCC38C43P	ACTIVE	PDIP	P	8	50	Pb-Free (RoHS)	CU NIPDAU	Level-NC-NC-NC
UCC38C44D	ACTIVE	SOIC	D	8	75	None	CU NIPDAU	Level-1-220C-UNLIM
UCC38C44DGK	ACTIVE	MSOP	DGK	8	100	None	CU SNPB	Level-1-220C-UNLIM
UCC38C44DGKR	ACTIVE	MSOP	DGK	8	2500	None	CU SNPB	Level-1-220C-UNLIM
UCC38C44DR	ACTIVE	SOIC	D	8	2500	None	CU NIPDAU	Level-1-220C-UNLIM
UCC38C44P	ACTIVE	PDIP	P	8	50	Pb-Free (RoHS)	CU NIPDAU	Level-NC-NC-NC
UCC38C45D	ACTIVE	SOIC	D	8	75	None	CU NIPDAU	Level-1-220C-UNLIM
UCC38C45DGK	ACTIVE	MSOP	DGK	8	100	None	CU NIPDAU	Level-1-220C-UNLIM
UCC38C45DGKR	ACTIVE	MSOP	DGK	8	2500	None	CU NIPDAU	Level-1-220C-UNLIM
UCC38C45DR	ACTIVE	SOIC	D	8	2500	None	CU NIPDAU	Level-1-220C-UNLIM
UCC38C45P	ACTIVE	PDIP	P	8	50	Pb-Free (RoHS)	Call TI	Level-NC-NC-NC

⁽¹⁾ The marketing status values are defined as follows:

ACTIVE: Product device recommended for new designs.

LIFEBUY: TI has announced that the device will be discontinued, and a lifetime-buy period is in effect.

NRND: Not recommended for new designs. Device is in production to support existing customers, but TI does not recommend using this part in a new design.

PREVIEW: Device has been announced but is not in production. Samples may or may not be available.

OBsolete: TI has discontinued the production of the device.

⁽²⁾ Eco Plan - May not be currently available - please check <http://www.ti.com/productcontent> for the latest availability information and additional product content details.

None: Not yet available Lead (Pb-Free).

Pb-Free (RoHS): TI's terms "Lead-Free" or "Pb-Free" mean semiconductor products that are compatible with the current RoHS requirements for all 6 substances, including the requirement that lead not exceed 0.1% by weight in homogeneous materials. Where designed to be soldered at high temperatures, TI Pb-Free products are suitable for use in specified lead-free processes.

Green (RoHS & no Sb/Br): TI defines "Green" to mean "Pb-Free" and in addition, uses package materials that do not contain halogens, including bromine (Br) or antimony (Sb) above 0.1% of total product weight.

⁽³⁾ MSL, Peak Temp. -- The Moisture Sensitivity Level rating according to the JEDEC industry standard classifications, and peak solder temperature.

Important Information and Disclaimer: The information provided on this page represents TI's knowledge and belief as of the date that it is provided. TI bases its knowledge and belief on information provided by third parties, and makes no representation or warranty as to the accuracy of such information. Efforts are underway to better integrate information from third parties. TI has taken and continues to take reasonable steps to provide representative and accurate information but may not have conducted destructive testing or chemical analysis on incoming materials and chemicals. TI and TI suppliers consider certain information to be proprietary, and thus CAS numbers and other limited information may not be available for release.

In no event shall TI's liability arising out of such information exceed the total purchase price of the TI part(s) at issue in this document sold by TI to Customer on an annual basis.

P (R-PDIP-T8)

PLASTIC DUAL-IN-LINE

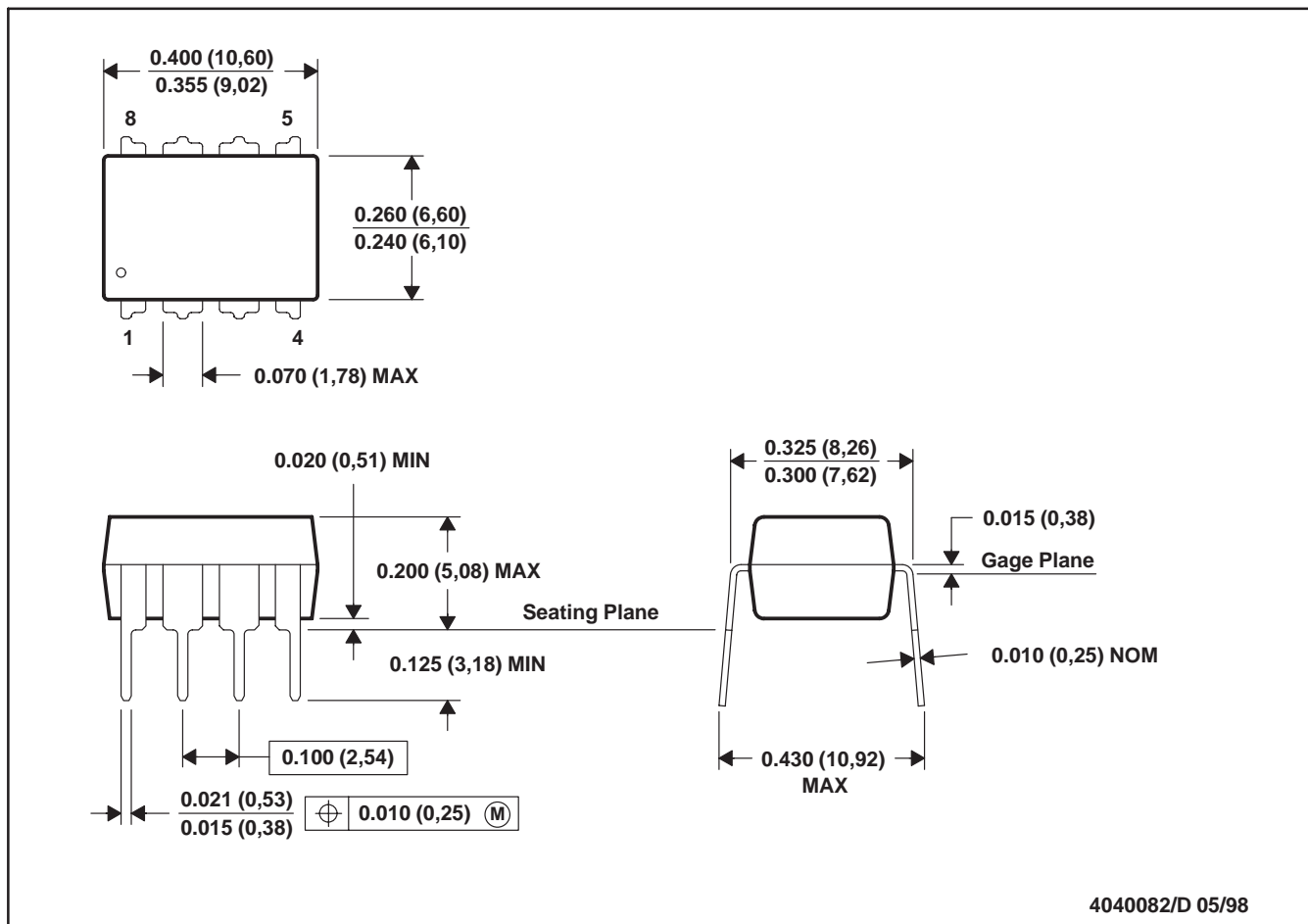

4040082/D 05/98

- NOTES: A. All linear dimensions are in inches (millimeters).
 B. This drawing is subject to change without notice.
 C. Falls within JEDEC MS-001

For the latest package information, go to http://www.ti.com/sc/docs/package/pkg_info.htm



DGK (S-PDSO-G8)

PLASTIC SMALL-OUTLINE PACKAGE

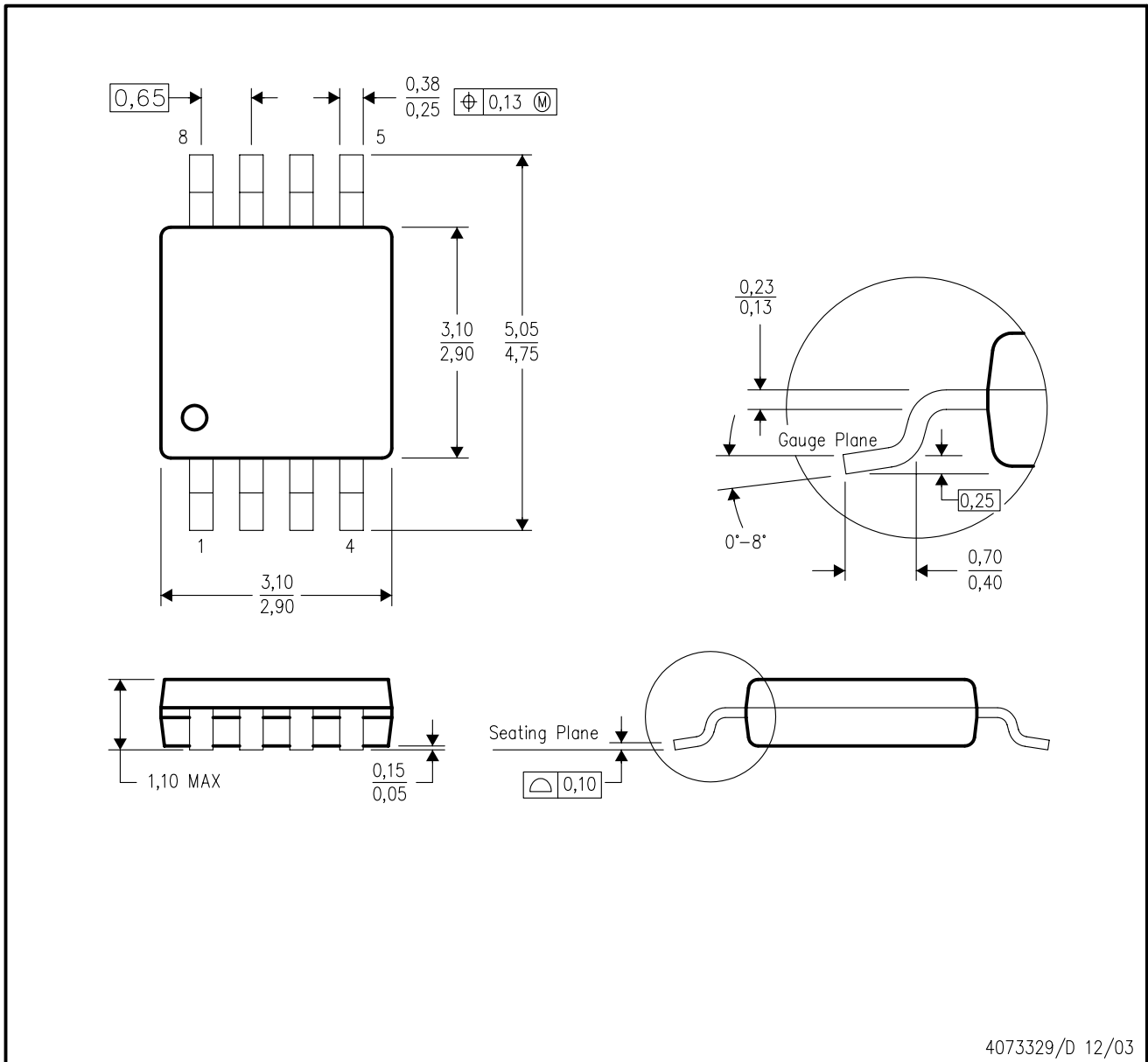

- NOTES:
- A. All linear dimensions are in millimeters.
 - B. This drawing is subject to change without notice.
 - C. Body dimensions do not include mold flash or protrusion.
 - D. Falls within JEDEC MO-187 variation AA.

D (R-PDSO-G8)

PLASTIC SMALL-OUTLINE PACKAGE

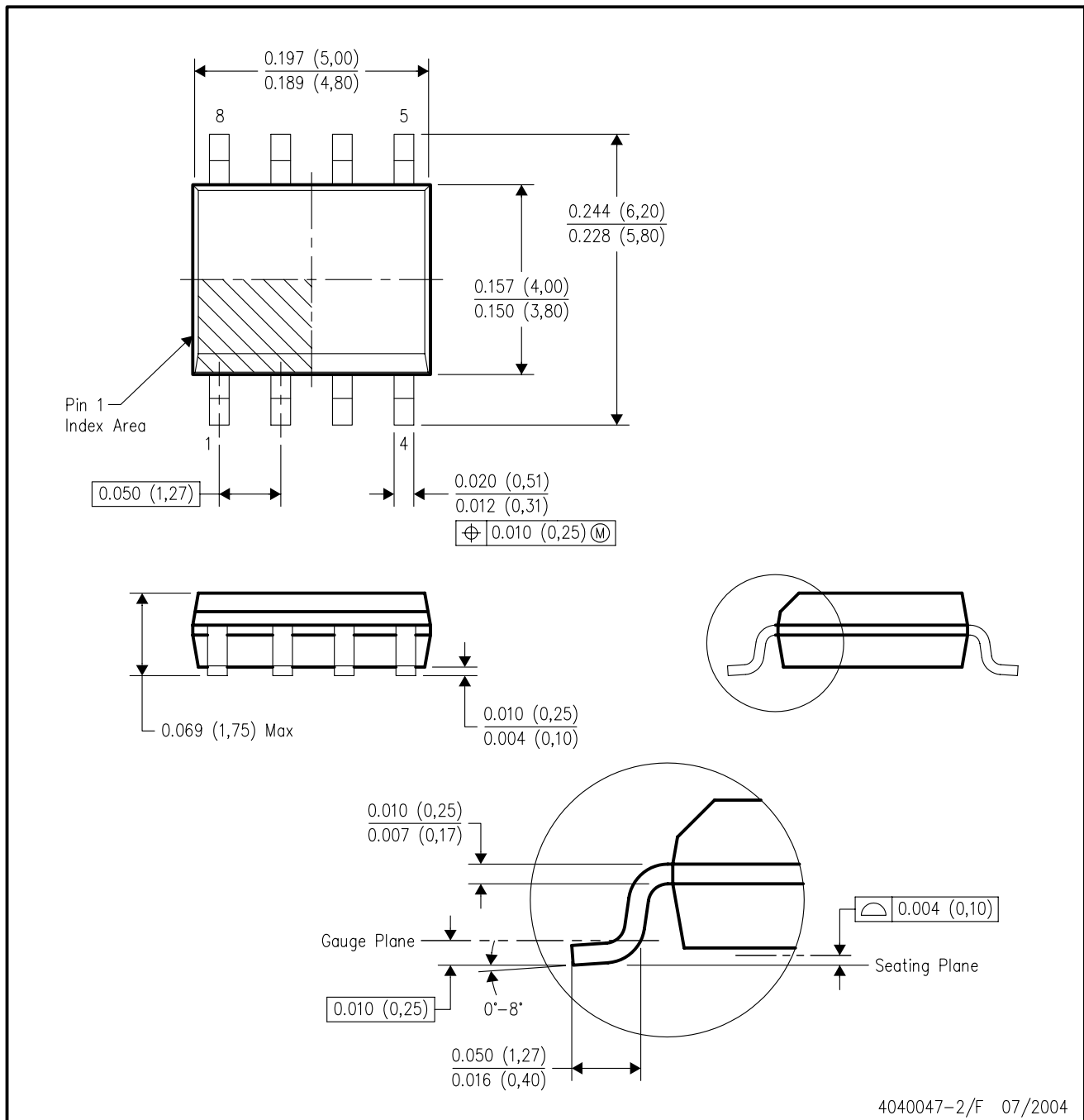

- NOTES:
- A. All linear dimensions are in inches (millimeters).
 - B. This drawing is subject to change without notice.
 - C. Body dimensions do not include mold flash or protrusion not to exceed 0.006 (0,15).
 - D. Falls within JEDEC MS-012 variation AA.

IMPORTANT NOTICE

Texas Instruments Incorporated and its subsidiaries (TI) reserve the right to make corrections, modifications, enhancements, improvements, and other changes to its products and services at any time and to discontinue any product or service without notice. Customers should obtain the latest relevant information before placing orders and should verify that such information is current and complete. All products are sold subject to TI's terms and conditions of sale supplied at the time of order acknowledgment.

TI warrants performance of its hardware products to the specifications applicable at the time of sale in accordance with TI's standard warranty. Testing and other quality control techniques are used to the extent TI deems necessary to support this warranty. Except where mandated by government requirements, testing of all parameters of each product is not necessarily performed.

TI assumes no liability for applications assistance or customer product design. Customers are responsible for their products and applications using TI components. To minimize the risks associated with customer products and applications, customers should provide adequate design and operating safeguards.

TI does not warrant or represent that any license, either express or implied, is granted under any TI patent right, copyright, mask work right, or other TI intellectual property right relating to any combination, machine, or process in which TI products or services are used. Information published by TI regarding third-party products or services does not constitute a license from TI to use such products or services or a warranty or endorsement thereof. Use of such information may require a license from a third party under the patents or other intellectual property of the third party, or a license from TI under the patents or other intellectual property of TI.

Reproduction of information in TI data books or data sheets is permissible only if reproduction is without alteration and is accompanied by all associated warranties, conditions, limitations, and notices. Reproduction of this information with alteration is an unfair and deceptive business practice. TI is not responsible or liable for such altered documentation.

Resale of TI products or services with statements different from or beyond the parameters stated by TI for that product or service voids all express and any implied warranties for the associated TI product or service and is an unfair and deceptive business practice. TI is not responsible or liable for any such statements.

Following are URLs where you can obtain information on other Texas Instruments products and application solutions:

Products		Applications	
Amplifiers	amplifier.ti.com	Audio	www.ti.com/audio
Data Converters	dataconverter.ti.com	Automotive	www.ti.com/automotive
DSP	dsp.ti.com	Broadband	www.ti.com/broadband
Interface	interface.ti.com	Digital Control	www.ti.com/digitalcontrol
Logic	logic.ti.com	Military	www.ti.com/military
Power Mgmt	power.ti.com	Optical Networking	www.ti.com/opticalnetwork
Microcontrollers	microcontroller.ti.com	Security	www.ti.com/security
		Telephony	www.ti.com/telephony
		Video & Imaging	www.ti.com/video
		Wireless	www.ti.com/wireless

Mailing Address: Texas Instruments
Post Office Box 655303 Dallas, Texas 75265