

Frequency Foldback Current Mode PWM Controller

FEATURES

- Frequency Foldback Reduces Operating Frequency Under Fault Conditions
- Accurate Programmable Volt-Second Clamp
- Programmable Maximum Duty Cycle Clamp
- Oscillator Synchronization
- Overcurrent Protection
- Shutdown with Full Soft Start
- Wide Gain Bandwidth Amplifier (GBW > 2.5MHz)
- Current Mode Operation
- Precision 5V Reference

DESCRIPTION

The UCC3884 is a high performance current mode PWM controller intended for single ended switch mode power supplies. The chip implements a frequency foldback scheme that decreases the oscillator frequency as the output voltage falls below a programmed value. This technique decreases the average output current sourced into a low impedance load which can occur during an output short circuit or overload condition. Excessive short circuit current is more prevalent in high frequency converters where the propagation delay and switch turn-off time forces a minimum attainable duty cycle. An accurate volt-second clamp limits the duty cycle during line or load transient conditions which could otherwise saturate the transformer. The volt-second clamp may also be used with an external overvoltage protection circuit to handle fault conditions such as current sense disconnect or current transformer saturation. The frequency foldback, volt-second clamp, cycle-by-cycle current limit, and overcurrent shutdown provide a rich set of protection features for use in peak current mode pulse width modulators.

BLOCK DIAGRAM

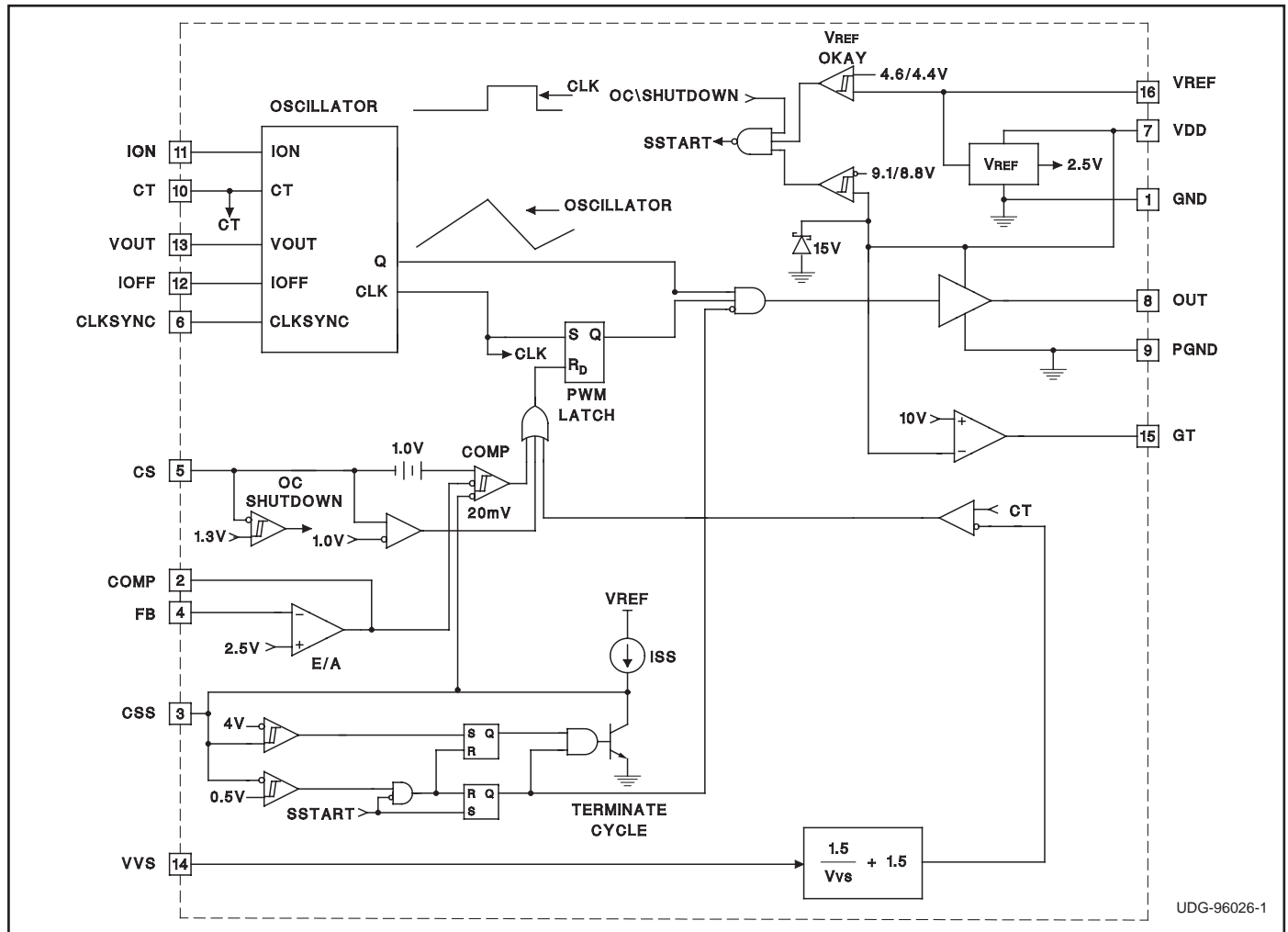

UDG-96026-1

ABSOLUTE MAXIMUM RATINGS

Supply Voltage	15V
Output Sink Current	1A
Output Source Current	0.5A
All Other Pins	6V
Storage Temperature	-65°C to +150°C
Junction Temperature	-55°C to +150°C
Lead Temperature (Soldering, 10 sec.)	+300°C

Currents are positive into, negative out of the specified terminal. Consult Packaging Section of Databook for thermal limitations and considerations of packages.

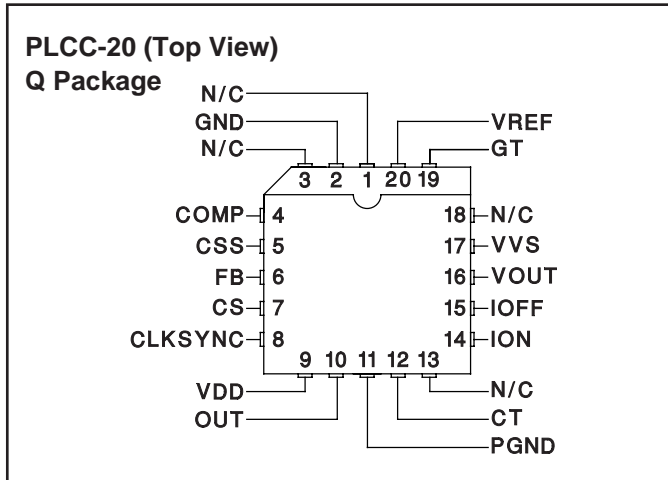

CONNECTION DIAGRAMS

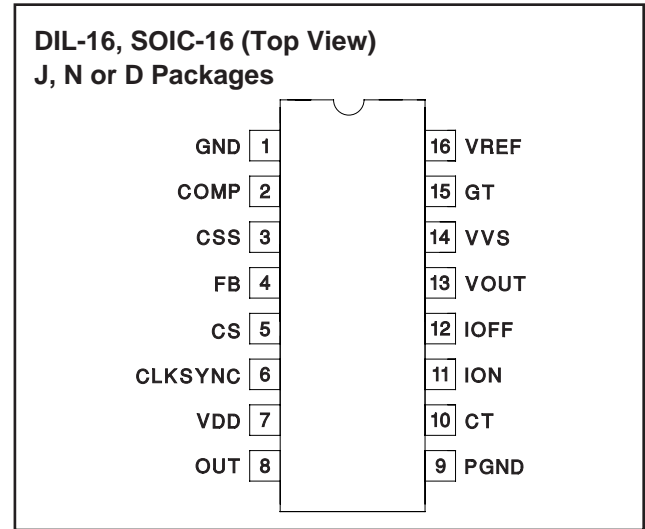

ELECTRICAL CHARACTERISTICS: Unless otherwise specified, these specifications apply for $T_A = -55^\circ\text{C}$ to 125°C for the UCC1884, -40°C to 85°C for the UCC2884, and 0°C to 70°C for the UCC3884, $C_T = 220\text{pF}$, $R_{ON} = 53\text{k}$, $R_{OFF} = 38\text{k}$, $V_{OUT} = V_{REF}$, $V_{VS} = 0\text{V}$, $C_{SS} = 2.5\text{nF}$, $V_{DD} = 11\text{V}$, Output no load, $T_A = T_J$.

PARAMETER	TEST CONDITIONS	MIN	TYP	MAX	UNITS
5V Reference Section					
VREF	$I_{REF} = 0\text{mA}$	4.86	5	5.14	V
Line Regulation	$V_{DD} = 10\text{V}$ to 12V		1	10	mV
Load Regulation	$0 < I_{REF} < 5\text{mA}$		1	20	mV
Short Circuit I	$V_{REF} = 0\text{V}$		15	45	mA
Oscillator Section					
Accuracy	$V_{OUT} = V_{REF}$	360	400	440	kHz
Foldback Frequency	$V_{OUT} = 0.75\text{V}$	200	230	260	kHz
CLKSYNC Output High		4.8	5	5.2	V
CLKSYNC Output Low			0.0	0.4	V
CLKSYNC Sink Current	$CLKSYNC = 1\text{V}$	1.2	2.2		mA
CLKSYNC Source Current	$CLKSYNC = 3\text{V}$		-0.2	-0.1	mA
CLKSYNC Input Threshold	$CLKSYNC$ from 5V to 0V (Edge Detect)	2.5	3.0	3.5	V
Error Amplifier Section					
I_B	Total Bias Current; Regulating Level	-1		1	μA
FB Voltage	$FB = COMP$	2.43	2.5	2.57	V
A_{vo}		50	90		dB
GBW	$F = 100\text{kHz}$ (Note 1)	2.5	5		MHz
Output Source Current	$FB = 2.3\text{V}$, $COMP = 2.5\text{V}$	-0.6	-1.2		mA
Output Sink Current	$FB = 2.7\text{V}$, $V_{COMP} = 1\text{V}$	0.250	1.5		mA
V_{OL}	$I_O = 100\mu\text{A}$		0.3	0.9	V
V_{OH}	$I_O = -100\mu\text{A}$	2.7	3.1	3.5	V

ELECTRICAL CHARACTERISTICS: Unless otherwise specified, these specifications apply for $T_A = -55^{\circ}\text{C}$ to 125°C for the UCC1884, -40°C to 85°C for the UCC2884, and 0°C to 70°C for the UCC3884, $C_T = 220\text{pF}$, $R_{ON} = 53\text{k}$, $R_{OFF} = 38\text{k}$, $V_{OUT} = V_{REF}$, $V_{VS} = 0\text{V}$, $C_{SS} = 2.5\text{nF}$, $V_{DD} = 11\text{V}$, Output no load, $T_A = T_J$.

PARAMETER	TEST CONDITIONS	MIN	TYP	MAX	UNITS
PWM Section					
Minimum Duty Cycle	FB = 3V, CS = 0V			0	%
Maximum Duty Cycle	FB = 0V, CS = 0V	75	78	81	%
Current Sense Section					
Input Bias Current (CS)				3.0	μA
CS Shutdown Threshold		1.235	1.3	1.365	V
CS Shutdown Hysteresis			20		mV
CS Over Current Threshold		0.95	1	1.05	V
Current/Fault Section					
Soft Start Charge Current		-10	-20	-30	μA
Soft Start Discharge Current		10	20	30	μA
V_{OL}			0	50	mV
Soft Start Complete Threshold		3.6	4	4.4	V
Soft Start Restart Threshold		0.4	0.5	0.6	V
Volt Second Clamp					
Duty Cycle	VVS = 1.4V, $T_A = 0^{\circ}\text{C}$ to 70°C	53.8	56.8	59.8	%
	VVS = 3.6V, $T_A = -55^{\circ}\text{C}$ to 125°C	19.8	22	26.0	%
	VVS = 3.6V, $T_A = -40^{\circ}\text{C}$ to 85°C	20.9	22	25.0	%
	VVS = 3.6V, $T_A = 0^{\circ}\text{C}$ to 70°C	21	22	23	%
I_B	VVS = 3.7V	-1		+1	μA
Output Stage					
Output Low Saturation	$I_{OUT} = 100\text{mA}$		0.5	0.9	V
Output High Saturation	$I_{OUT} = -50\text{mA}$		0.5	0.9	V
	$I_{OUT} = -200\text{mA}$ (Note 1)			1.9	V
UVLO Output Low Saturation	$I_{OUT} = 20\text{mA}$, $V_{DD} = 0\text{V}$		0.7	1.2	V
Rise Time	$C_L = 1\text{nF}$		50	70	ns
Fall Time	$C_L = 1\text{nF}$		30	50	ns
Undervoltage Lockout					
Turn-On Threshold Voltage		8.4	8.9	9.4	V
Hysteresis		200	600	1000	mV
Startup Regulator					
Regulated VDD Voltage		9.5	10	10.5	V
VDD Override Threshold				10.7	V
Overall					
V_{DD} Range				14.5	V
I_{DD} (run)	$f = 400\text{kHz}$	2	5	10	mA
I_{DD} Startup Current	$V_{DD} = 5.4\text{V}$	100		250	μA
VDD Clamp	$I_{DD} = 10\text{mA}$	12	13.5	15	V

Note 1: Guaranteed by design. Not 100% tested in production.

PIN DESCRIPTIONS

CLKSYNC: An edge triggered active low TTL signal to this pin synchronizes the oscillator to an external clock. When VOUT decreases below 3.0V, the frequency foldback circuit is activated and the controller becomes unsynchronized. When VOUT exceeds 3.0V, the controller resynchronizes to the external clock.

COMP: The output of the voltage error amplifier used for compensation. The output is clamped to 3.0V minimum.

CS: Current sense input. This pin accepts a voltage proportional to converter inductor current. The voltage at CS is compared to the output of the compensated error amplifier to control the on-time of the switch. Voltage mode control can be realized by driving this pin with a fixed sawtooth ramp. Voltage feedforward is achieved by making the peak of this ramp proportional to the input voltage.

CSS: A capacitor, CSS, to ground programs the soft start time for the power up sequence. This function is also used when an overcurrent fault occurs. As CSS is charged, the PWM comparator uses the lowest of either the voltage at CSS or the error amplifier output voltage to determine the duty cycle. The duty cycle, therefore, slowly increases during the soft start cycle. The faults that cause CSS to discharge and shutdown the controller are the logical OR of VREF below 4.4V or VDD below 8.8V. If a fault is still present when CSS is discharged below 0.5V, the supply remains off until the fault is cleared. The soft start time is determined by:

$$T_{SS} = 3.5 \cdot \frac{C_{SS}}{I_{SS}}$$

where I_{SS} is 20μA. A current limit terminates the present cycle. It does not generate a soft start cycle.

CT: A capacitor, CT to ground, is charged and discharged creating the oscillator waveform. This waveform varies between 1.5V and 3.5V. The operating frequency is determined by:

$$f = \frac{4.4}{C_T \cdot \left(\frac{R_{ON}}{1.5} + \frac{R_{OFF}}{3.5} \right)}$$

The ratio of the time duration of the positive sloped portion of the CT voltage waveform to the period gives the maximum duty cycle.

FB: The inverting input of the voltage amplifier used to sense the output voltage. The non-inverting input of the error amplifier is internally connected to 2.5V.

GND: The ground pin internally used for all the amplifiers and as the return for all resistor and capacitor connections to the UCC3884.

GT: Used to drive an external depletion-mode MOSFET for the housekeeping power supply. The MOSFET is turned off when the bootstrap winding voltage exceeds 10V. There is 300mV of hysteresis around the 10V turn-off voltage to prevent oscillation. See Typical Application.

IOFF: A resistor, ROFF, to ground, programs the discharge current of the timing capacitor CT. This is a variable discharge current which determines the negative slope of the oscillator voltage waveform at CT. The discharge time is dependent on the voltage at the VOUT pin. The discharge current is given by IOFF = VOUT/ROFF. The VOUT pin is internally clamped to 3.5V maximum.

ION: A resistor, RON, to ground programs the charge current of the timing capacitor, CT, which generates the positive slope of the oscillator waveform. The charge time is constant and corresponds to the maximum output on-time at OUT. The charge current equation is ION = 1.5V/RON. When required the linear positive slope of the CT voltage could be buffered and used to provide slope compensation into the CS pin.

OUT: The output of the controller. The peak source current is 0.5A and the peak sink current is 1.0A. The faults listed under the CSS description turn off this output.

PGND: The power ground pin is used as the return for the output transistor drive stage.

VDD: The input voltage of the chip. A low ESR and ESL ceramic capacitor from this pin to GND should be used to bypass internal switching transients.

VOUT: This pin accomplishes frequency foldback by controlling the discharge current for the oscillator CT capacitor. A dc voltage proportional to the output voltage is connected to this pin. To startup with zero output voltage the user should tie a resistor between VREF and VOUT. The value depends on the lowest desired operating frequency. When VOUT decreases below 3.5V the frequency decreases by reducing the discharge current IOFF. When VOUT increases, the frequency increases by increasing the discharge current. The maximum operating frequency occurs when VOUT = 3.5V. The CT charge time is constant to guarantee a maximum output duty cycle. This pin must be above 3.0V to allow synchronization to occur.

PIN DESCRIPTIONS (cont.)

VREF: This pin is the output of the 5V regulated reference. Bypass this pin with a low ESR and ESL ceramic capacitor (e.g., 0.47 μ F).

VVS: Provides a programmable duty cycle clamp which is dependent upon the input voltage. A resistor divider network reduces the input voltage supplied to VVS. The

IC determines the reciprocal of the voltage at VVS and scales the result. The voltage is then compared to the oscillator waveform to clamp the duty cycle. The purpose of this clamp is to reduce the likelihood of saturating the isolation transformer during unusual line or load conditions.

APPLICATION INFORMATION

Theory of Operation

The UCC3884 current mode PWM controller contains a programmable oscillator which includes the ability to synchronize multiple PWMs. The positive and negative sloped portions of the oscillator waveform (measured at CT), have time intervals that are set by external resistors at ION and IOFF. The operating frequency is inversely proportional to the timing capacitor. The negative sloped portion of the oscillator waveform is extended in time as the measured output voltage decreases providing protection during output faults. The power supply output voltage and the voltage from VREF are fed back to VOUT. When the output voltage decreases, the voltage at VOUT also decreases. As VOUT decreases below 3.5V, the operating frequency decreases. This reduction in frequency allows the duty cycle to decrease below what the CS to OUT delay would otherwise permit. This is referred to as frequency foldback. An output short circuit or overload causes the converter to enter the frequency foldback mode. Synchronization to other controllers can only occur during normal operation, that is, when VOUT is greater than 3.0V.

GT is provided to turn off an external depletion-mode MOSFET after startup when the bootstrap winding exceeds 10V. This depletion-mode MOSFET is used in the housekeeping section of the converter to simplify startup biasing circuitry. The amplifier that drives this MOSFET has 300mV of hysteresis to avoid oscillation during power up.

An accurate programmable volt-second technique clamps the duty cycle. The duty cycle limit is inversely proportional to input voltage and a resistor divider network is used to program the proportionality constant. At a given input voltage and constant load, under closed loop control, the operating duty cycle is a fixed value. The volt-second clamp duty cycle may then be set somewhat higher than this operating duty cycle. For other input voltages, the volt-second clamp will still exceed the steady state operating duty cycle. This allows normal closed loop operation of the converter. It is during

a load transient (a fault such as a momentary short circuit) as the error amplifier increases the duty cycle, that when the volt-second clamp accurately limits the maximum volt-seconds. This ensures that the transformer does not saturate during a fault which can fail the power supply. After the fault is removed the converter resumes closed loop control.

CSS is provided which allows the UCC3884 to be disabled with an external transistor. The increasing pulse width at OUT during soft start should be programmed to be less than the pulse width of the duty cycle limit that the frequency foldback circuitry creates. The frequency foldback circuit will be in effect during soft start since the output voltage fed back to VOUT is less than 3.5V. Designing the circuit in this fashion allows a proper startup sequence.

The current sense feedback pin has an overcurrent protection feature which forces a soft start cycle only if the IC is not currently in a soft start cycle. A 1V bias at the PWM comparator's non-inverting input and a reset dominant PWM latch permit zero duty cycle operation.

The error amplifier has a wide gain-bandwidth product and its non-inverting input is internally set to 2.5VDC.

Oscillator

The oscillator has charge and discharge currents programmed with resistors to ground from ION and IOFF respectively, as seen on the Oscillator Block Diagram (Fig. 1). This generates a linear sawtooth waveform on CT. Frequency foldback is accomplished by the level shifted output voltage controlling the VOUT voltage which decreases the discharge current and the frequency.

Synchronization is accomplished by coupling the fastest oscillator CLKS SYNC signal as shown on the Oscillator Synchronization Diagram (Fig. 2). The fastest (master) CLKS SYNC pin will couple a negative pulse into the slower (slave) CLKS SYNC pins forcing the slaves' CT pins to quickly discharge as shown on the Oscillator Waveform diagram (Fig. 3).

APPLICATION INFORMATION (cont.)

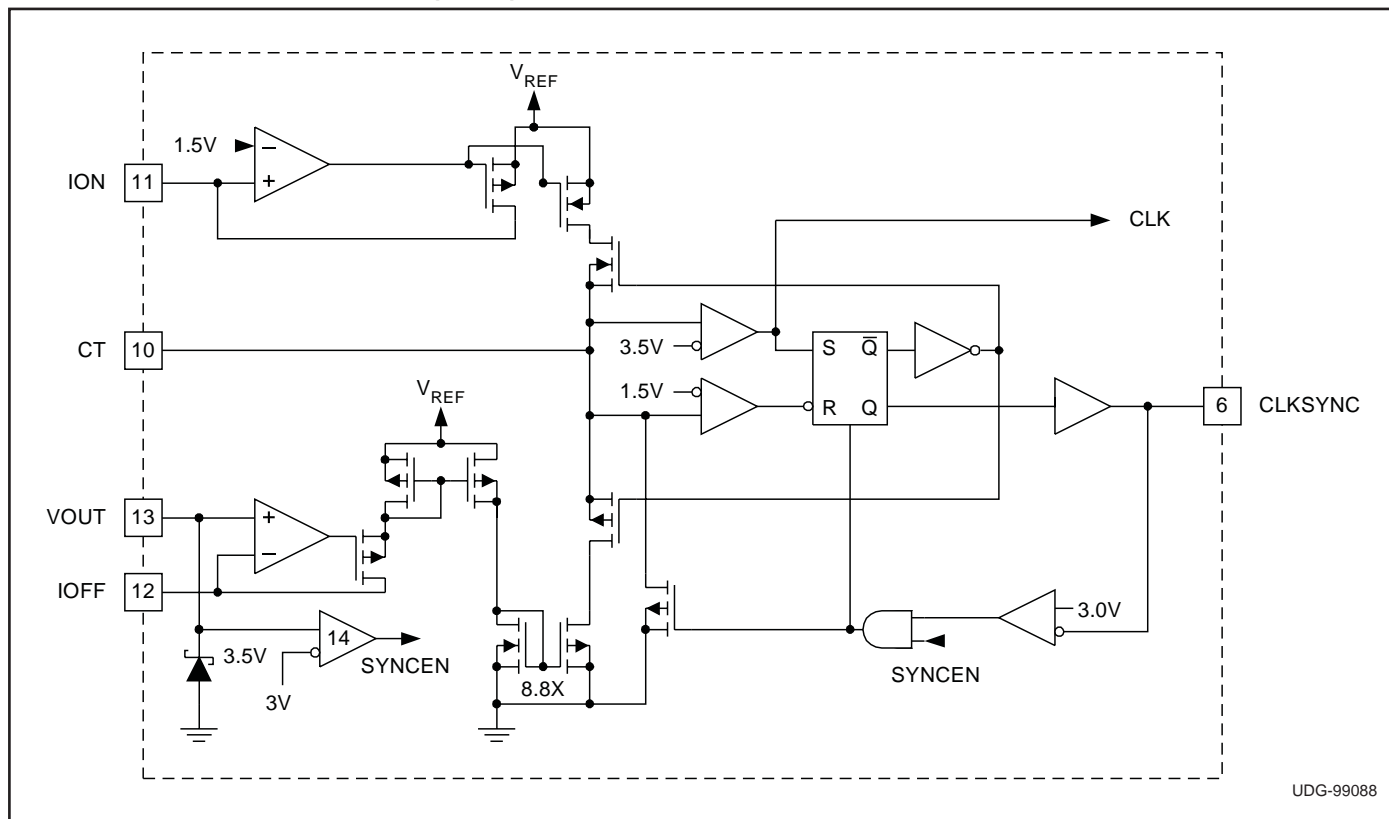

Figure 1. UCC3884 oscillator.

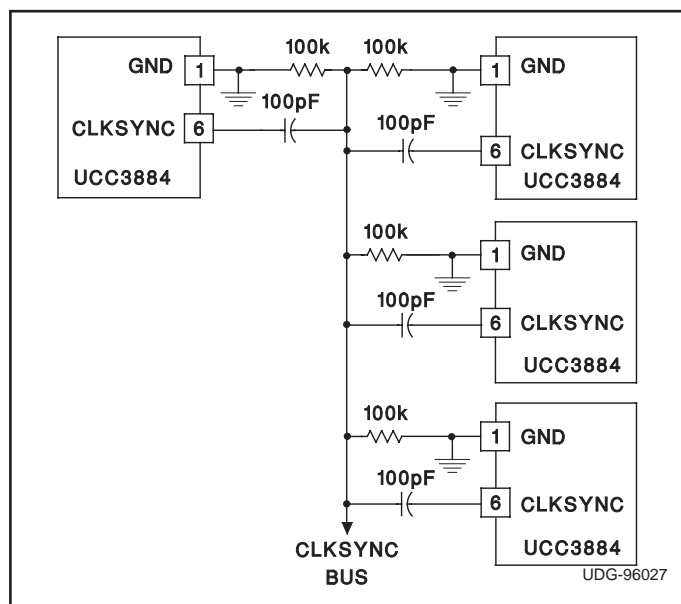

Figure 2. Oscillator synchronization connection diagram.

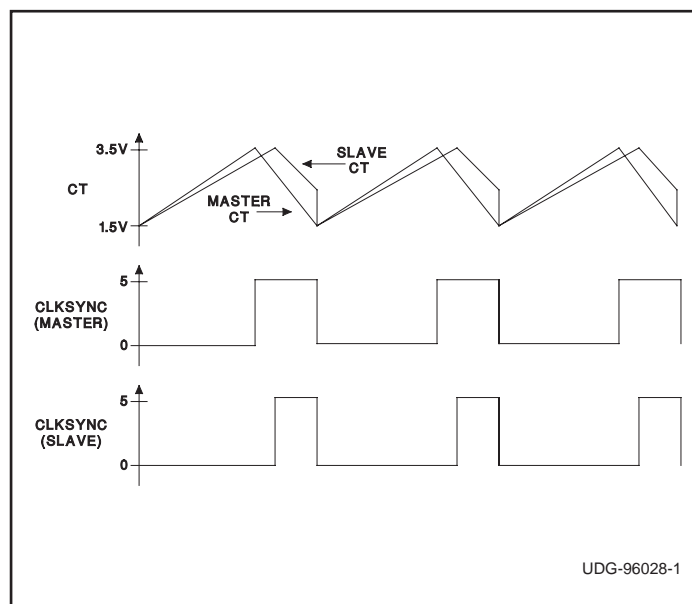

Figure 3. Oscillator waveforms.

PACKAGING INFORMATION

Orderable Device	Status ⁽¹⁾	Package Type	Package Drawing	Pins	Package Qty	Eco Plan ⁽²⁾	Lead/Ball Finish	MSL Peak Temp ⁽³⁾
UCC3884D	ACTIVE	SOIC	D	16	40	None	CU NIPDAU	Level-1-220C-UNLIM
UCC3884DTR	ACTIVE	SOIC	D	16	2500	None	CU NIPDAU	Level-1-220C-UNLIM
UCC3884N	ACTIVE	PDIP	N	16	25	None	CU NIPDAU	Level-NA-NA-NA

⁽¹⁾ The marketing status values are defined as follows:

ACTIVE: Product device recommended for new designs.

LIFEBUY: TI has announced that the device will be discontinued, and a lifetime-buy period is in effect.

NRND: Not recommended for new designs. Device is in production to support existing customers, but TI does not recommend using this part in a new design.

PREVIEW: Device has been announced but is not in production. Samples may or may not be available.

OBSOLETE: TI has discontinued the production of the device.

⁽²⁾ Eco Plan - May not be currently available - please check <http://www.ti.com/productcontent> for the latest availability information and additional product content details.

None: Not yet available Lead (Pb-Free).

Pb-Free (RoHS): TI's terms "Lead-Free" or "Pb-Free" mean semiconductor products that are compatible with the current RoHS requirements for all 6 substances, including the requirement that lead not exceed 0.1% by weight in homogeneous materials. Where designed to be soldered at high temperatures, TI Pb-Free products are suitable for use in specified lead-free processes.

Green (RoHS & no Sb/Br): TI defines "Green" to mean "Pb-Free" and in addition, uses package materials that do not contain halogens, including bromine (Br) or antimony (Sb) above 0.1% of total product weight.

⁽³⁾ MSL, Peak Temp. -- The Moisture Sensitivity Level rating according to the JEDEC industry standard classifications, and peak solder temperature.

Important Information and Disclaimer: The information provided on this page represents TI's knowledge and belief as of the date that it is provided. TI bases its knowledge and belief on information provided by third parties, and makes no representation or warranty as to the accuracy of such information. Efforts are underway to better integrate information from third parties. TI has taken and continues to take reasonable steps to provide representative and accurate information but may not have conducted destructive testing or chemical analysis on incoming materials and chemicals. TI and TI suppliers consider certain information to be proprietary, and thus CAS numbers and other limited information may not be available for release.

In no event shall TI's liability arising out of such information exceed the total purchase price of the TI part(s) at issue in this document sold by TI to Customer on an annual basis.

IMPORTANT NOTICE

Texas Instruments Incorporated and its subsidiaries (TI) reserve the right to make corrections, modifications, enhancements, improvements, and other changes to its products and services at any time and to discontinue any product or service without notice. Customers should obtain the latest relevant information before placing orders and should verify that such information is current and complete. All products are sold subject to TI's terms and conditions of sale supplied at the time of order acknowledgment.

TI warrants performance of its hardware products to the specifications applicable at the time of sale in accordance with TI's standard warranty. Testing and other quality control techniques are used to the extent TI deems necessary to support this warranty. Except where mandated by government requirements, testing of all parameters of each product is not necessarily performed.

TI assumes no liability for applications assistance or customer product design. Customers are responsible for their products and applications using TI components. To minimize the risks associated with customer products and applications, customers should provide adequate design and operating safeguards.

TI does not warrant or represent that any license, either express or implied, is granted under any TI patent right, copyright, mask work right, or other TI intellectual property right relating to any combination, machine, or process in which TI products or services are used. Information published by TI regarding third-party products or services does not constitute a license from TI to use such products or services or a warranty or endorsement thereof. Use of such information may require a license from a third party under the patents or other intellectual property of the third party, or a license from TI under the patents or other intellectual property of TI.

Reproduction of information in TI data books or data sheets is permissible only if reproduction is without alteration and is accompanied by all associated warranties, conditions, limitations, and notices. Reproduction of this information with alteration is an unfair and deceptive business practice. TI is not responsible or liable for such altered documentation.

Resale of TI products or services with statements different from or beyond the parameters stated by TI for that product or service voids all express and any implied warranties for the associated TI product or service and is an unfair and deceptive business practice. TI is not responsible or liable for any such statements.

Following are URLs where you can obtain information on other Texas Instruments products and application solutions:

Products		Applications	
Amplifiers	amplifier.ti.com	Audio	www.ti.com/audio
Data Converters	dataconverter.ti.com	Automotive	www.ti.com/automotive
DSP	dsp.ti.com	Broadband	www.ti.com/broadband
Interface	interface.ti.com	Digital Control	www.ti.com/digitalcontrol
Logic	logic.ti.com	Military	www.ti.com/military
Power Mgmt	power.ti.com	Optical Networking	www.ti.com/opticalnetwork
Microcontrollers	microcontroller.ti.com	Security	www.ti.com/security
		Telephony	www.ti.com/telephony
		Video & Imaging	www.ti.com/video
		Wireless	www.ti.com/wireless

Mailing Address: Texas Instruments
Post Office Box 655303 Dallas, Texas 75265