

ULQ2003A-Q1, ULQ2004A-Q1, HIGH-VOLTAGE HIGH-CURRENT DARLINGTON TRANSISTOR ARRAY

SGLS148A – DECEMBER 2002 – REVISED OCTOBER 2004

- Qualification in Accordance With AEC-Q100†
- Qualified for Automotive Applications
- Customer-Specific Configuration Control Can Be Supported Along With Major-Change Approval
- ESD Protection Exceeds 200 V Using Machine Model (C = 200 pF, R = 0)
- 500-mA Rated Collector Current (Single Output)
- High-Voltage Outputs . . . 50 V
- Output Clamp Diodes
- Inputs Compatible With Various Types of Logic
- Relay-Driver Applications

† Contact Texas Instruments for details. Q100 qualification data available on request.

D PACKAGE
(TOP VIEW)

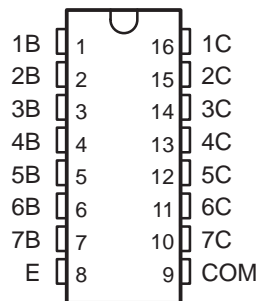

description

The ULQ2003A-Q1 and ULQ2004A-Q1 are high-voltage, high-current Darlington transistor arrays. Each consists of seven npn Darlington pairs that feature high-voltage outputs with common-cathode clamp diodes for switching inductive loads. The collector-current rating of a single Darlington pair is 500 mA. The Darlington pairs can be paralleled for higher current capability. Applications include relay drivers, hammer drivers, lamp drivers, display drivers (LED and gas discharge), line drivers, and logic buffers.

The ULQ2003A-Q1 has a 2.7-k Ω series base resistor for each Darlington pair, for operation directly with TTL or 5-V CMOS devices. The ULQ2004A-Q1 has a 10.5-k Ω series base resistor to allow operation directly from CMOS devices that use supply voltages of 6 V to 15 V. The required input current of the ULQ2004A-Q1 is below that of the ULQ2003A-Q1.

AVAILABLE OPTIONS

T _A	D PACKAGES†
	SMALL OUTLINE
-40°C to 105°C	ULQ2003ATDQ1 ULQ2003ATDRQ1
	ULQ2004ATDQ1‡ ULQ2004ATDRQ1

† The D package is available taped and reeled. Add the suffix R to device type (e.g., ULQ2003TDADRQ1).

‡ ULQ2004ATDQ1 is Product Preview only.



Please be aware that an important notice concerning availability, standard warranty, and use in critical applications of Texas Instruments semiconductor products and disclaimers thereto appears at the end of this data sheet.

PRODUCTION DATA information is current as of publication date. Products conform to specifications per the terms of Texas Instruments standard warranty. Production processing does not necessarily include testing of all parameters.

 **TEXAS
INSTRUMENTS**

POST OFFICE BOX 655303 • DALLAS, TEXAS 75265

Copyright © 2004, Texas Instruments Incorporated

ULQ2003A-Q1, ULQ2004A-Q1, HIGH-VOLTAGE HIGH-CURRENT DARLINGTON TRANSISTOR ARRAY

SGLS148A – DECEMBER 2002 – REVISED OCTOBER 2004

logic diagram

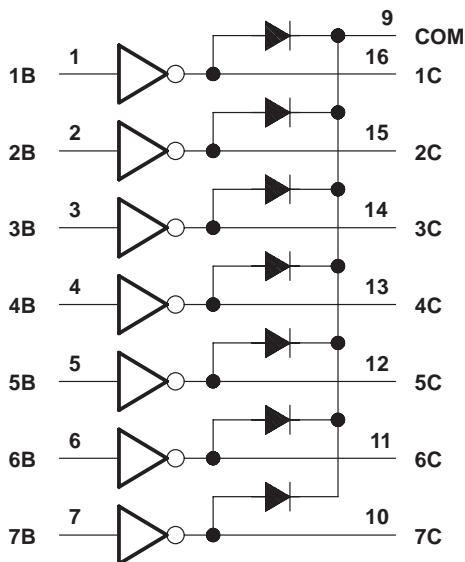

schematics (each Darlington pair)

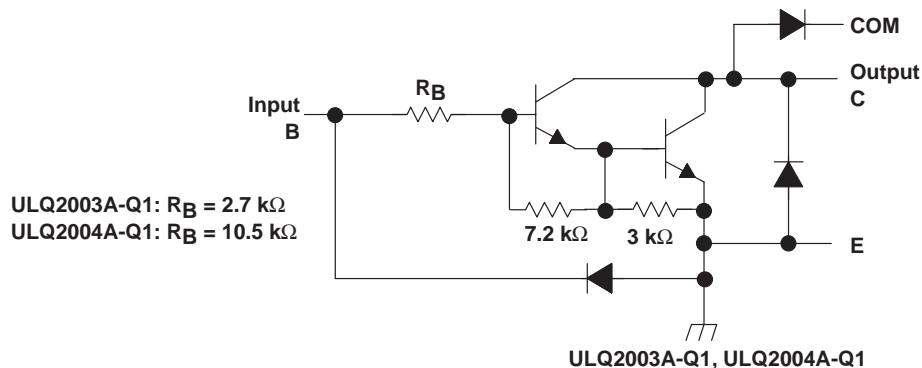

All resistor values shown are nominal.

absolute maximum ratings at 25°C free-air temperature (unless otherwise noted)†

Collector-emitter voltage	50 V
Clamp diode reverse voltage (see Note 1)	50 V
Input voltage, V_I (see Note 1)	30 V
Peak collector current (see Figure 14)	500 mA
Output clamp current, I_{OK}	500 mA
Total emitter-terminal current	-2.5 A
Continuous total power dissipation	See Dissipation Rating Table
Package thermal impedance, θ_{JA} (see Note 2)	73°C/W
Operating free-air temperature range, T_A	-40°C to 105°C
Lead temperature 1,6 mm (1/16 inch) from case for 10 seconds	260°C
Storage temperature range, T_{STG}	-65°C to 150°C

† Stresses beyond those listed under “absolute maximum ratings” may cause permanent damage to the device. These are stress ratings only, and functional operation of the device at these or any other conditions beyond those indicated under “recommended operating conditions” is not implied. Exposure to absolute-maximum-rated conditions for extended periods may affect device reliability.

NOTES: 1. All voltage values are with respect to the emitter/substrate terminal E, unless otherwise noted.
 2. The package thermal impedance is calculated in accordance with JESD 51-7.



ULQ2003A-Q1, ULQ2004A-Q1, HIGH-VOLTAGE HIGH-CURRENT DARLINGTON TRANSISTOR ARRAY

SGLS148A – DECEMBER 2002 – REVISED OCTOBER 2004

DISSIPATION RATING TABLE

PACKAGE	$T_A = 25^\circ\text{C}$ POWER RATING	DERATING FACTOR ABOVE $T_A = 25^\circ\text{C}$	$T_A = 85^\circ\text{C}$ POWER RATING	$T_A = 105^\circ\text{C}$ POWER RATING
D	950 mW	7.6 mW/°C	494 mW	342 mW

electrical characteristics over recommended operating conditions (unless otherwise noted)

PARAMETER	TEST CONDITIONS	ULQ2003A-Q1			ULQ2004A-Q1			UNIT
		MIN	TYP	MAX	MIN	TYP	MAX	
$V_{I(on)}$ On-state input voltage, See Figure 6	$V_{CE} = 2\text{ V}$	$I_C = 125\text{ mA}$					5	V
		$I_C = 200\text{ mA}$			2.7		6	
		$I_C = 250\text{ mA}$			2.9			
		$I_C = 275\text{ mA}$					7	
		$I_C = 300\text{ mA}$			3			
		$I_C = 350\text{ mA}$					8	
$V_{CE(sat)}$ Collector-emitter saturation voltage, See Figure 5	$I_I = 250\ \mu\text{A}, I_C = 100\text{ mA}$		0.9	1.2		0.9	1.1	V
	$I_I = 350\ \mu\text{A}, I_C = 200\text{ mA}$		1	1.4		1	1.3	
	$I_I = 500\ \mu\text{A}, I_C = 350\text{ mA}$		1.2	1.7		1.2	1.6	
I_{CEX} Collector cutoff current	$V_{CE} = 50\text{ V}, I_I = 0,$ See Figure 1			100			50	μA
	$V_{CE} = 50\text{ V},$ See Figure 2	$I_I = 0$ $V_I = 1\text{ V}$					100 500	
V_F Clamp forward voltage, See Figure 8	$I_F = 350\text{ mA}$		1.7	2.2		1.7	2.1	V
$I_{I(off)}$ Off-state input current, See Figure 3	$V_{CE} = 50\text{ V}, I_C = 500\ \mu\text{A}$	30	65		50	65		μA
I_I Input current, see Figure 4	$V_I = 3.85\text{ V}$		0.93	1.35				mA
	$V_I = 5\text{ V}$				0.35	0.5		
	$V_I = 12\text{ V}$				1	1.45		
I_R Clamp reverse current, See Figure 7	$V_R = 50\text{ V}, T_A = 25^\circ\text{C}$			100			50	μA
	$V_R = 50\text{ V}$			100			100	
C_i Input capacitance	$V_I = 0, f = 1\text{ MHz}$		15	25		15	25	pF

switching characteristics over recommended operating conditions (unless otherwise noted)

PARAMETER	TEST CONDITIONS	ULQ2003A-Q1, ULQ2004A-Q1			UNIT
		MIN	TYP	MAX	
t_{PLH} Propagation delay time, low-to-high level output	See Figure 9		1	10	μs
t_{PHL} Propagation delay time, high-to-low level output	See Figure 9		1	10	μs
V_{OH} High-level output voltage after switching	$V_S = 50\text{ V}, I_O \approx 300\text{ mA},$ See Figure 10		$V_S - 500$		mV



ULQ2003A-Q1, ULQ2004A-Q1, HIGH-VOLTAGE HIGH-CURRENT DARLINGTON TRANSISTOR ARRAY

SGLS148A – DECEMBER 2002 – REVISED OCTOBER 2004

PARAMETER MEASUREMENT INFORMATION

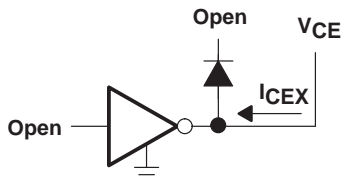

Figure 1. I_{CEX} Test Circuit

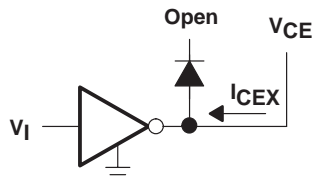

Figure 2. I_{CEX} Test Circuit

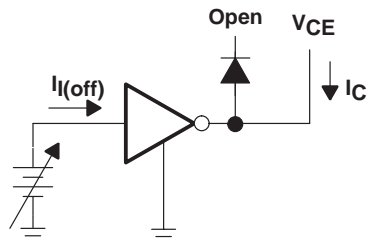

Figure 3. $I_{I(off)}$ Test Circuit

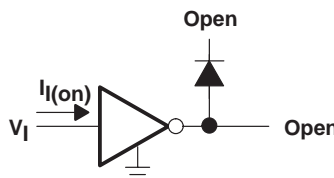
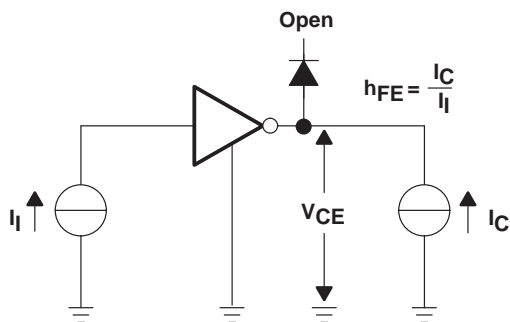

Figure 4. I_I Test Circuit



NOTE: I_I is fixed for measuring $V_{CE(sat)}$, variable for measuring h_{FE} .

Figure 5. h_{FE} , $V_{CE(sat)}$ Test Circuit

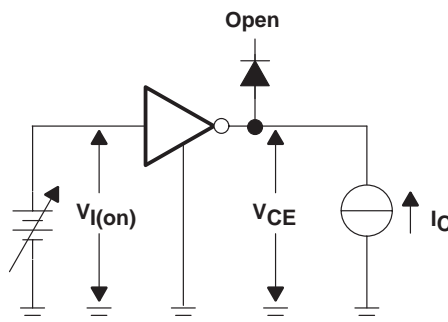

Figure 6. $V_{I(on)}$ Test Circuit

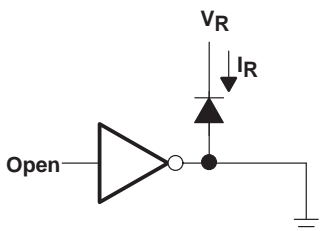

Figure 7. I_R Test Circuit

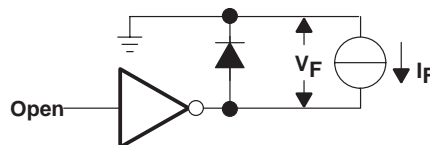

Figure 8. V_F Test Circuit

PARAMETER MEASUREMENT INFORMATION

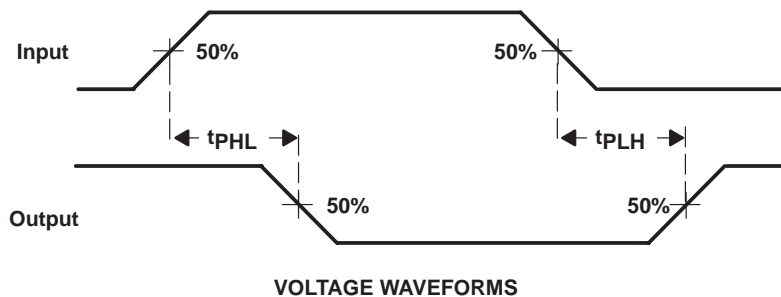
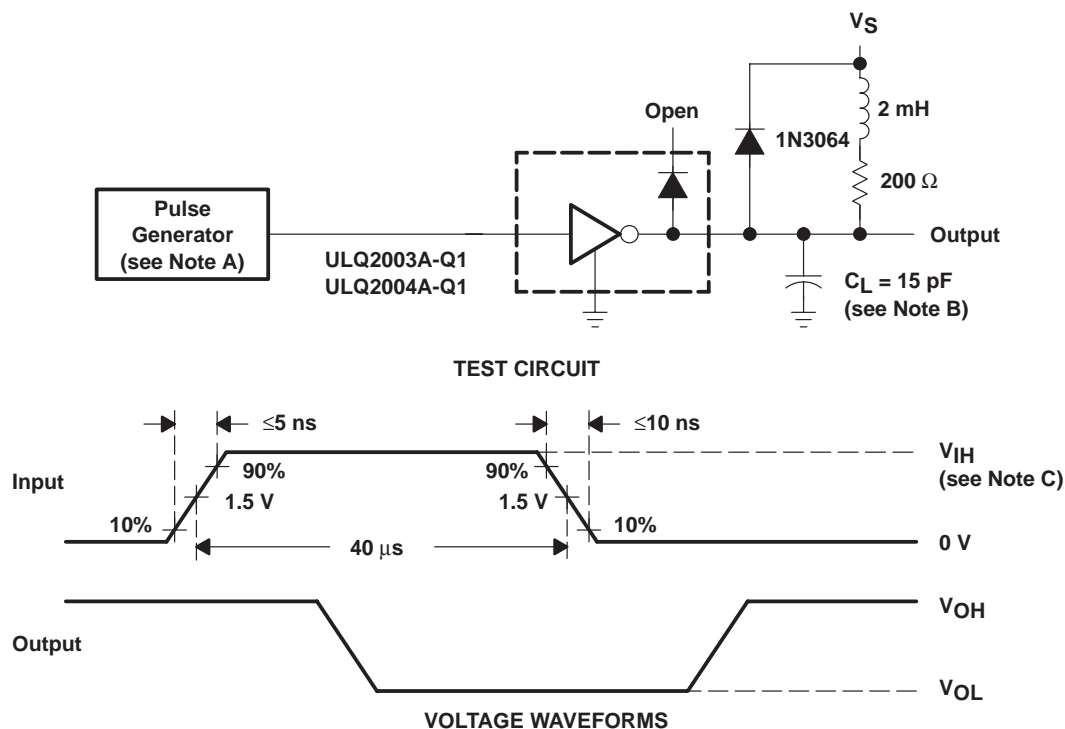

Figure 9. Propagation Delay-Time Waveforms



- NOTES: A. The pulse generator has the following characteristics: PRR = 12.5 kHz, $Z_O = 50 \Omega$.
 B. C_L includes probe and jig capacitance.
 C. For testing the ULQ2003A-Q1, $V_{IH} = 3 \text{ V}$; for the ULQ2004A-Q1, $V_{IH} = 8 \text{ V}$.

Figure 10. Latch-Up Test Circuit and Voltage Waveforms

ULQ2003A-Q1, ULQ2004A-Q1, HIGH-VOLTAGE HIGH-CURRENT DARLINGTON TRANSISTOR ARRAY

SGLS148A – DECEMBER 2002 – REVISED OCTOBER 2004

TYPICAL CHARACTERISTICS

COLLECTOR-EMITTER SATURATION VOLTAGE
vs
COLLECTOR CURRENT
(ONE DARLINGTON)

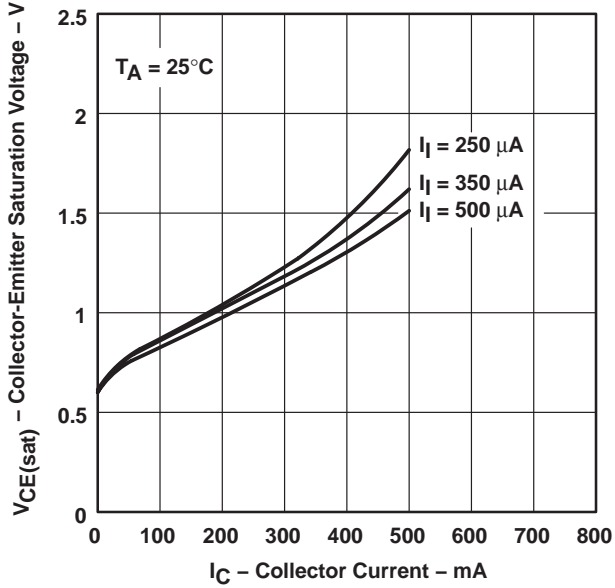

Figure 11

COLLECTOR-EMITTER SATURATION VOLTAGE
vs
TOTAL COLLECTOR CURRENT
(TWO DARLINGTONS IN PARALLEL)

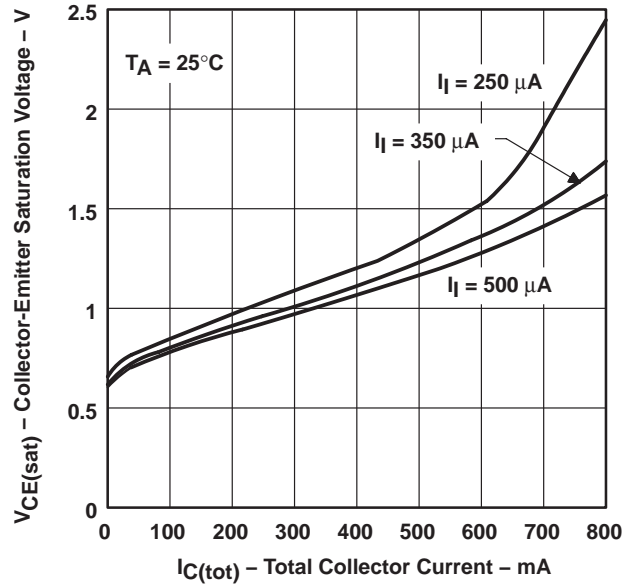

Figure 12

COLLECTOR CURRENT
vs
INPUT CURRENT

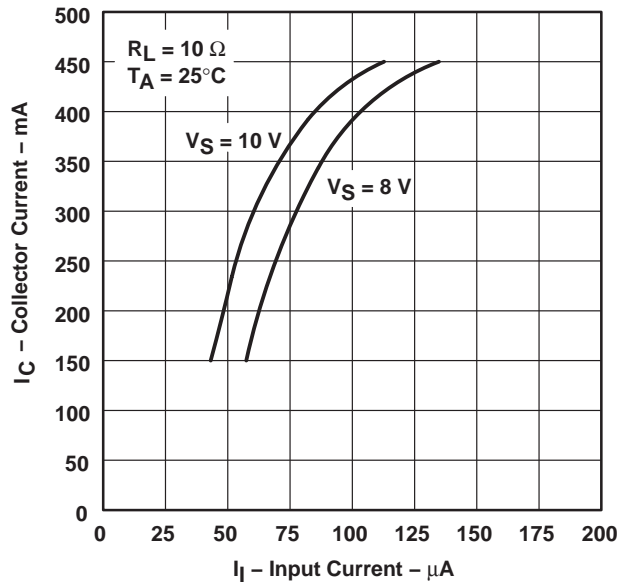

Figure 13

THERMAL INFORMATION

MAXIMUM COLLECTOR CURRENT
vs
DUTY CYCLE

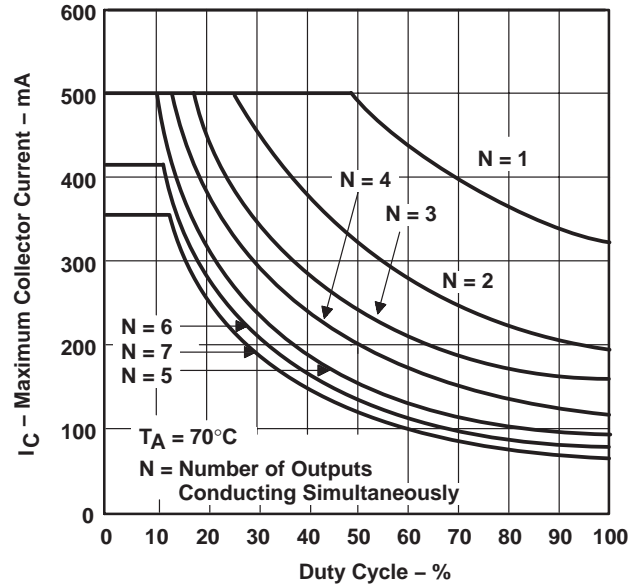

Figure 14

ULQ2003A-Q1, ULQ2004A-Q1, HIGH-VOLTAGE HIGH-CURRENT DARLINGTON TRANSISTOR ARRAY

SGLS148A – DECEMBER 2002 – REVISED OCTOBER 2004

APPLICATION INFORMATION

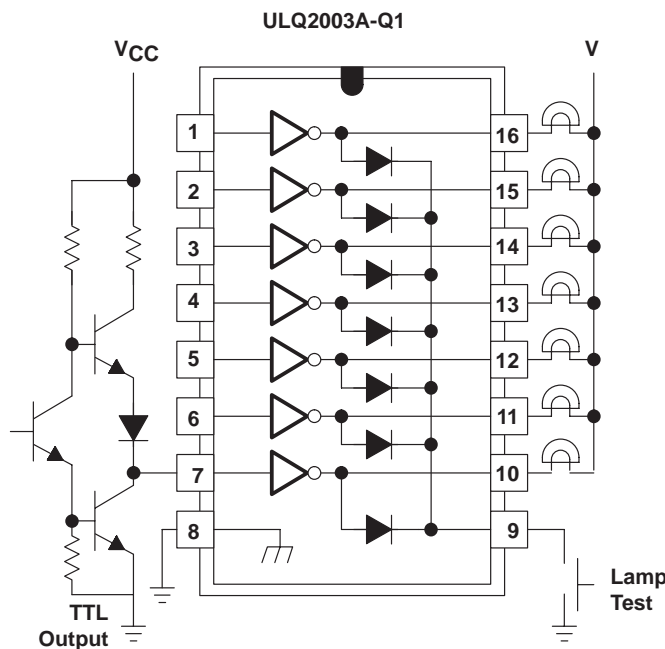

Figure 15. TTL to Load

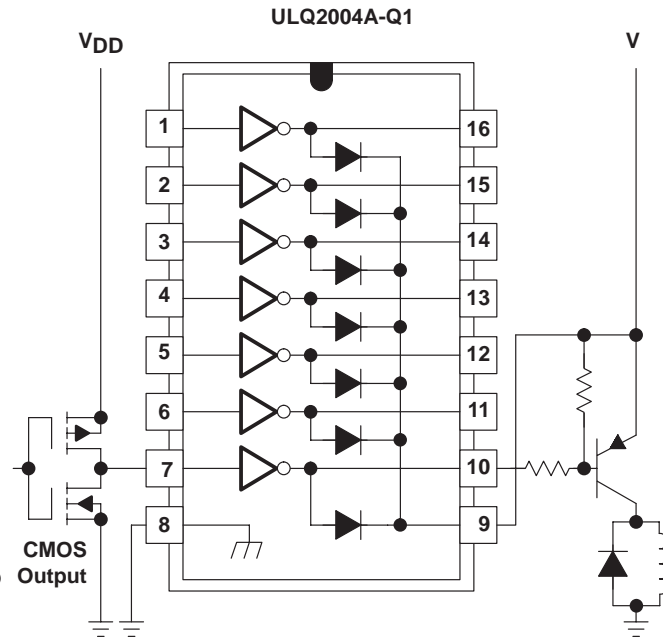

Figure 16. Buffer for Higher Current Loads

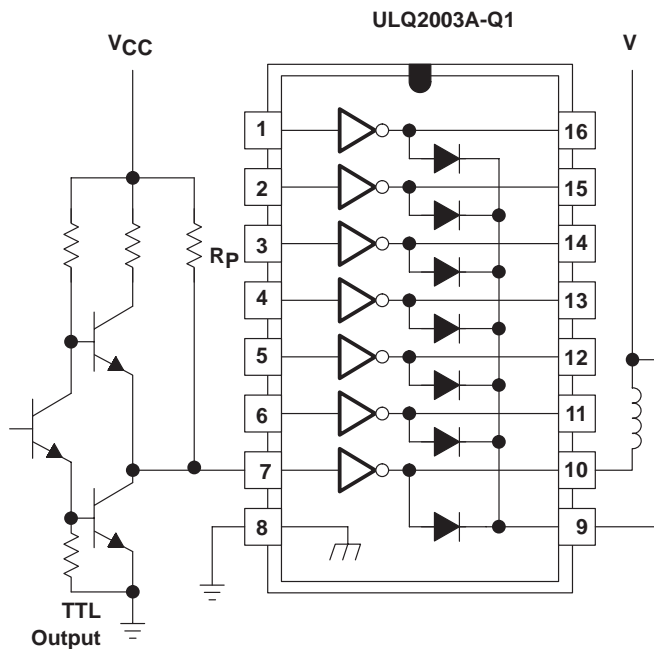

Figure 17. Use of Pullup Resistors
to Increase Drive Current

PACKAGING INFORMATION

Orderable Device	Status ⁽¹⁾	Package Type	Package Drawing	Pins	Package Qty	Eco Plan ⁽²⁾	Lead/Ball Finish	MSL Peak Temp ⁽³⁾
ULQ2003ATDQ1	ACTIVE	SOIC	D	16	40	Pb-Free (RoHS)	CU NIPDAU	Level-2-250C-1 YEAR/ Level-1-235C-UNLIM
ULQ2003ATDRQ1	ACTIVE	SOIC	D	16	2500	Pb-Free (RoHS)	CU NIPDAU	Level-2-250C-1 YEAR/ Level-1-235C-UNLIM
ULQ2004ATDRQ1	ACTIVE	SOIC	D	16	2500	Pb-Free (RoHS)	CU NIPDAU	Level-2-250C-1 YEAR/ Level-1-235C-UNLIM

⁽¹⁾ The marketing status values are defined as follows:

ACTIVE: Product device recommended for new designs.

LIFEBUY: TI has announced that the device will be discontinued, and a lifetime-buy period is in effect.

NRND: Not recommended for new designs. Device is in production to support existing customers, but TI does not recommend using this part in a new design.

PREVIEW: Device has been announced but is not in production. Samples may or may not be available.

OBsolete: TI has discontinued the production of the device.

⁽²⁾ Eco Plan - May not be currently available - please check <http://www.ti.com/productcontent> for the latest availability information and additional product content details.

None: Not yet available Lead (Pb-Free).

Pb-Free (RoHS): TI's terms "Lead-Free" or "Pb-Free" mean semiconductor products that are compatible with the current RoHS requirements for all 6 substances, including the requirement that lead not exceed 0.1% by weight in homogeneous materials. Where designed to be soldered at high temperatures, TI Pb-Free products are suitable for use in specified lead-free processes.

Green (RoHS & no Sb/Br): TI defines "Green" to mean "Pb-Free" and in addition, uses package materials that do not contain halogens, including bromine (Br) or antimony (Sb) above 0.1% of total product weight.

⁽³⁾ MSL, Peak Temp. -- The Moisture Sensitivity Level rating according to the JEDEC industry standard classifications, and peak solder temperature.

Important Information and Disclaimer:The information provided on this page represents TI's knowledge and belief as of the date that it is provided. TI bases its knowledge and belief on information provided by third parties, and makes no representation or warranty as to the accuracy of such information. Efforts are underway to better integrate information from third parties. TI has taken and continues to take reasonable steps to provide representative and accurate information but may not have conducted destructive testing or chemical analysis on incoming materials and chemicals. TI and TI suppliers consider certain information to be proprietary, and thus CAS numbers and other limited information may not be available for release.

In no event shall TI's liability arising out of such information exceed the total purchase price of the TI part(s) at issue in this document sold by TI to Customer on an annual basis.

D (R-PDSO-G16)

PLASTIC SMALL-OUTLINE PACKAGE



- NOTES:
- A. All linear dimensions are in inches (millimeters).
 - B. This drawing is subject to change without notice.
 - C. Body dimensions do not include mold flash or protrusion not to exceed 0.006 (0,15).
 - D. Falls within JEDEC MS-012 variation AC.

IMPORTANT NOTICE

Texas Instruments Incorporated and its subsidiaries (TI) reserve the right to make corrections, modifications, enhancements, improvements, and other changes to its products and services at any time and to discontinue any product or service without notice. Customers should obtain the latest relevant information before placing orders and should verify that such information is current and complete. All products are sold subject to TI's terms and conditions of sale supplied at the time of order acknowledgment.

TI warrants performance of its hardware products to the specifications applicable at the time of sale in accordance with TI's standard warranty. Testing and other quality control techniques are used to the extent TI deems necessary to support this warranty. Except where mandated by government requirements, testing of all parameters of each product is not necessarily performed.

TI assumes no liability for applications assistance or customer product design. Customers are responsible for their products and applications using TI components. To minimize the risks associated with customer products and applications, customers should provide adequate design and operating safeguards.

TI does not warrant or represent that any license, either express or implied, is granted under any TI patent right, copyright, mask work right, or other TI intellectual property right relating to any combination, machine, or process in which TI products or services are used. Information published by TI regarding third-party products or services does not constitute a license from TI to use such products or services or a warranty or endorsement thereof. Use of such information may require a license from a third party under the patents or other intellectual property of the third party, or a license from TI under the patents or other intellectual property of TI.

Reproduction of information in TI data books or data sheets is permissible only if reproduction is without alteration and is accompanied by all associated warranties, conditions, limitations, and notices. Reproduction of this information with alteration is an unfair and deceptive business practice. TI is not responsible or liable for such altered documentation.

Resale of TI products or services with statements different from or beyond the parameters stated by TI for that product or service voids all express and any implied warranties for the associated TI product or service and is an unfair and deceptive business practice. TI is not responsible or liable for any such statements.

Following are URLs where you can obtain information on other Texas Instruments products and application solutions:

Products		Applications	
Amplifiers	amplifier.ti.com	Audio	www.ti.com/audio
Data Converters	dataconverter.ti.com	Automotive	www.ti.com/automotive
DSP	dsp.ti.com	Broadband	www.ti.com/broadband
Interface	interface.ti.com	Digital Control	www.ti.com/digitalcontrol
Logic	logic.ti.com	Military	www.ti.com/military
Power Mgmt	power.ti.com	Optical Networking	www.ti.com/opticalnetwork
Microcontrollers	microcontroller.ti.com	Security	www.ti.com/security
		Telephony	www.ti.com/telephony
		Video & Imaging	www.ti.com/video
		Wireless	www.ti.com/wireless

Mailing Address: Texas Instruments
Post Office Box 655303 Dallas, Texas 75265