

OM1905STM OM1912STM OM1915STM
 OM1905NTM OM1912NTM OM1915NTM

ISOLATED HERMETIC FIXED VOLTAGE NEGATIVE REGULATORS APPROVED TO DESC DRAWINGS

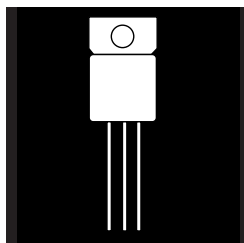

Three Terminal, Fixed Voltage, 1.5 Amp Precision Negative Regulators In Hermetic JEDEC TO-257AA Package

FEATURES

- Isolated Hermetic Package, JEDEC TO-257AA Outline
- Output Voltages: -5V, -12V, -15V
- Output Voltages Set Internally to $\pm 1\%$
- Built-In Thermal Overload Protection
- Short Circuit Current Limiting
- Product Is Also Available In Non-Isolated Package
- Similar To Industry Standards 7905, 7912, 7915

DESCRIPTION

These three terminal negative regulators are supplied in a hermetically sealed metal package whose outline is similar to the industry standard TO-220 plastic package. All protective features are designed into the circuit, including thermal shutdown, current limiting and safe-area control. With heat sinking, they can deliver over 1.5 amps of output current. These units feature internally trimmed output voltages to $\pm 1\%$ of nominal voltage. Standard voltages are -5V, -12V, -15V. These units are ideally suited for Military applications where a hermetically sealed package is required.

PART NUMBER DESIGNATOR

Standard Military Drawing Number	Omnirel Part Number
5962-8874601 UX	OM1905STM
5962-8874601 TX	OM1905NTM
5962-8874701 UX	OM1912STM
5962-8874701 TX	OM1912NTM
5962-8874801 UX	OM1915STM
5962-8874801 TX	OM1915NTM

“U” = Isolated

“T” = Non-Isolated

3.3

ABSOLUTE MAXIMUM RATINGS @ 25°C

Input Voltage -35 V
 Operating Junction Temperature Range -55°C to + 150°C
 Storage Temperature Range - 65°C to + 150°C

Typical Power/Thermal Characteristics:

Rated Power @ 25° C T_C 15W
 T_A 3W
 Thermal Resistance θ_{JC} (Case U) 4.2°C/W
 θ_{JC} (Case T) 3.5°C/W
 θ_{JA} 42°C/W

ELECTRICAL CHARACTERISTICS -5 Volt $V_{IN} = -10V, I_O = 500mA, -55^\circ C \quad T_A \quad 125^\circ C$ (unless otherwise specified)

Parameter	Symbol	Test Conditions	Min.	Max.	Unit
Output Voltage	V_{OUT}	$T_A = 25^\circ C$	-4.95	-5.05	V
		$V_{IN} = -7.5V$ to -20V $I_O = 5mA$ to 1.0, A, $P \leq 15W$	• -4.85	-5.15	V
Line Regulation (Note 1) (Note 4)	V_{RLINE}	$V_{IN} = -7.5V$ to -20V	•	12 25	mV mV
		$V_{IN} = -8.0V$ to -12V	•	5 12	mV mV
Load Regulation (Note 1)	V_{RLOAD}	$I_O = 5mA$ to 1.5 Amp	•	20 25	mV mV
		$I_O = 250mA$ to 750 mA	•	15 30	mV mV
Standby Current Drain	I_{SCD}		•	2.5 3.0	mA mA
			•	0.4	mA
Standby Current Drain Change With Line	ΔI_{SCD} (Line)	$V_{IN} = -7.0V$ to -20V	•	0.4	mA
Standby Current Drain Change With Load	ΔI_{SCD} (Load)	$I_O = 5mA$ to 1000mA	•	0.4	mA
Dropout Voltage	V_{DO}	$\Delta V_{OUT} = 100mV, I_O = 1.0A$	•	2.5	V
Peak Output Current	$I_{O(pk)}$	$T_A = 25^\circ C$	1.5	3.3	A
Short Circuit Current (Note 2)	I_{DS}	$V_{IN} = -35V$	•	1.2 2.8	A A
			•	63	dB
Ripple Rejection	$\frac{\Delta V_{IN}}{\Delta V_{OUT}}$	$f = 120$ Hz, $\Delta V_{IN} = -10V$	•	60	dB
		(Note 3)	•	60	dB
Output Noise Voltage (Note 3)	N_O	$T_A = 25^\circ C, f = 10$ Hz to 100KHz		40	$\mu V/V$ RMS
Long Term Stability (Note 3)	$\frac{\Delta V_{OUT}}{\Delta t}$	$T_A = 25^\circ C, t = 1000$ hrs.		75	mV

Notes:

- Load and Line Regulation are specified at a constant junction temperature. Pulse testing with low duty cycle is used. Changes in output voltage due to heating effects must be taken into account separately.
- Short Circuit protection is only assured up to $V_{IN} = -35V$.
- If not tested, shall be guaranteed to the specified limits.
 The • denotes the specifications which apply over the full operating temperature range.

3.3

OM1905STM/NTM - OM1915NTM/STM

ELECTRICAL CHARACTERISTICS -12 Volt $V_{IN} = -19V, I_O = 500mA, -55^{\circ}C \text{ } T_A \text{ } 125^{\circ}C$ (unless otherwise specified)

Parameter	Symbol	Test Conditions	Min.	Max.	Unit
Output Voltage	V_{OUT}	$T_A = 25^{\circ}C$	-11.88	-12.12	V
		$V_{IN} = -14.5V \text{ to } -27V$ $I_O = 5mA \text{ to } 1.0A, P \leq 15W$	• -11.64	-12.36	V
Line Regulation (Note 1) (Note 4)	V_{RLINE}	$V_{IN} = -14.5V \text{ to } -27V$		20	mV
		$V_{IN} = -16V \text{ to } -22V$		50	mV
Load Regulation (Note 1)	V_{RLOAD}	$I_O = 5mA \text{ to } 1.5A$		10	mV
		$I_O = 250mA \text{ to } 750mA$		30	mV
Standby Current Drain	I_{SCD}			32	mV
				60	mV
Standby Current Drain Change With Line	$D I_{SCD}$ (Line)	$V_{IN} = -14.5V \text{ to } -27V$		16	mV
				30	mV
Standby Current Drain Change With Load	$D I_{SCD}$ (Load)	$I_O = 5mA \text{ to } 1000mA$		3.5	mA
				4.0	mA
Dropout Voltage	V_{DO}	$DV_{OUT} = 100mV, I_O = 1.0A$	• 1.8		V
Peak Output Current	$I_{O(pk)}$	$T_A = 25^{\circ}C, I_O = 5mA \text{ to } 1A$	1.5	3.3	A
Short Circuit Current (Note 2)	I_{DS}	$V_{IN} = -35V$		1.2	A
				2.8	A
Ripple Rejection	$\frac{DV_{IN}}{DV_{OUT}}$	$f = 120Hz, DV_{IN} = -10V$	56		dB
		(Note 3)	• 53		dB
Output Noise Voltage (Note 3)	N_O	$T_A = 25^{\circ}C, f = 10Hz \text{ to } 100KHz$		40	$\mu V/V$ RMS
Long Term Stability (Note 3)	$\frac{DV_{OUT}}{Dt}$	$T_A = 25^{\circ}C, t = 1000hrs.$		120	mV

Notes:

- Load and Line Regulation are specified at a constant junction temperature. Pulse testing with low duty cycle is used. Changes in output voltage due to heating effects must be taken into account separately.
- Short Circuit protection is only assured up to $V_{IN} = -35V$.
- If not tested, shall be guaranteed to the specified limits.
The • denotes the specifications which apply over the full operating temperature range.
- Minimum load current for full line regulation = 5 mA.

MECHANICAL OUTLINE

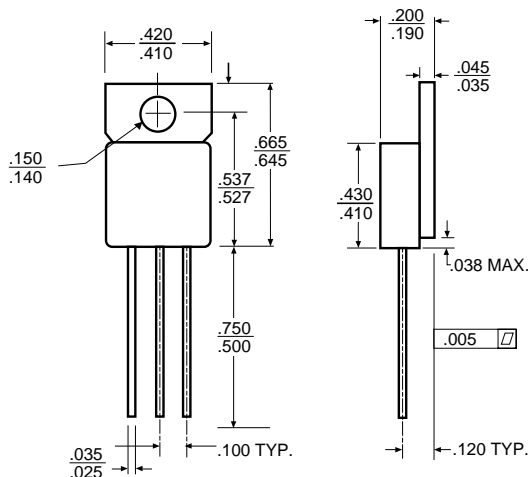

CONNECTION DIAGRAM

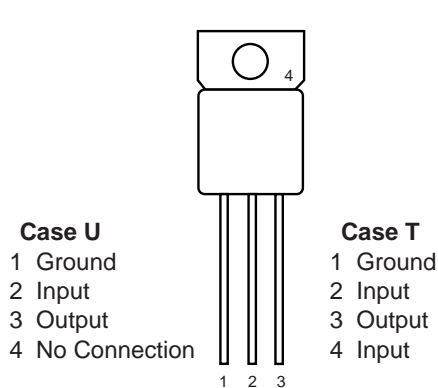

3.3

OM1905STM/NTM - OM1915STM/NTM

ELECTRICAL CHARACTERISTICS -15 Volt $V_{IN} = -23V$, $I_O = 500mA$, $-55^{\circ}C$ T_A $125^{\circ}C$ (unless otherwise specified)

Parameter	Symbol	Test Conditions	Min.	Max.	Unit
Output Voltage	V_{OUT}	$T_A = 25^{\circ}C$	-14.85	-15.15	V
		$V_{IN} = -17.5V$ to $-30V$ $I_O = 5mA$ to $1.0A$, $P \leq 15W$	• -14.55	-15.45	V
Line Regulation (Note 1) (Note 4)	V_{RLINE}	$V_{IN} = -17.5V$ to $-30V$		25	mV
			•	50	mV
		$V_{IN} = -20V$ to $-26V$		15	mV
		•	25	mV	
Load Regulation (Note 1)	V_{RLOAD}	$I_O = 5mA$ to $1.5A$ Amp		35	mV
			•	75	mV
		$I_O = 250mA$ to $750mA$		21	mV
		•	45	mV	
Standby Current Drain	I_{SCD}			6.0	mA
		•	6.5	mA	
Standby Current Drain Change With Line	ΔI_{SCD} (Line)	$V_{IN} = -17.5V$ to $-30V$	•	0.8	mA
Standby Current Drain Change With Load	ΔI_{SCD} (Load)	$I_O = 5mA$ to $1000mA$	•	0.5	mA
Dropout Voltage	V_{DO}	$\Delta V_{OUT} = 100mV$, $I_O = 1.0A$	•	2.5	V
Peak Output Current	$I_{O(pk)}$	$T_A = 25^{\circ}C$	1.5	3.3	A
Short Circuit Current (Note 2)	I_{DS}	$V_{IN} = -35V$		1.2	A
			•	2.8	A
Ripple Rejection	$\frac{\Delta V_{IN}}{\Delta V_{OUT}}$	$f = 120Hz$, $\Delta V_{IN} = -10V$		53	dB
		(Note 3)	•	50	dB
Output Noise Voltage (Note 3)	N_O	$T_A = 25^{\circ}C$, $f = 10Hz$ to $100KHz$		40	$\mu V/V$ RMS
Long Term Stability (Note 3)	$\frac{\Delta V_{OUT}}{Dt}$	$T_A = 25^{\circ}C$, $t = 1000hrs.$		150	mV

Notes:

- Load and Line Regulation are specified at a constant junction temperature. Pulse testing with low duty cycle is used. Changes in output voltage due to heating effects must be taken into account separately.
 - Short Circuit protection is only assured up to $V_{IN} = -35V$.
 - If not tested, shall be guaranteed to the specified limits.
- The • denotes the specifications which apply over the full operating temperature range.

TYPICAL PERFORMANCE CHARACTERISTICS

PEAK OUTPUT

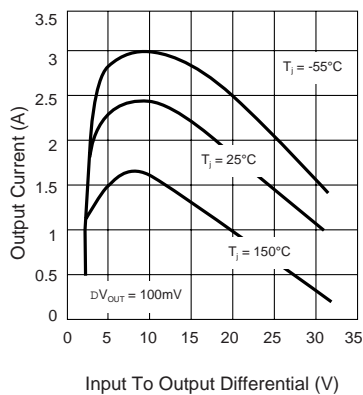

DROPOUT VOLTAGE

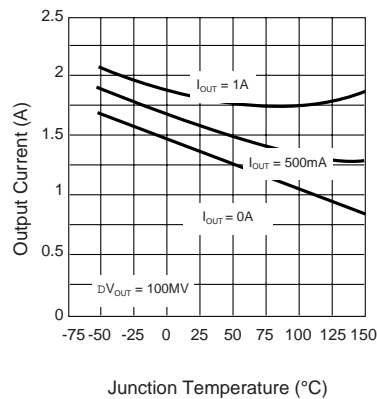

RIPPLE REJECTION

