

T-49-17-06

UM6502E

PRELIMINARY

8-Bit Microprocessor

Features

- UM6502E is the enhanced timing version of UM6502
- Single 5V ± 5% power supply
- N channel, silicon gate, depletion load technology
- 66 instructions
- Decimal and binary arithmetic
- Thirteen addressing modes
- True indexing capability
- Programmable stack pointer
- Variable length stack
- Interrupt capability
- Non-maskable Interrupt
- Bi-directional data bus
- Addressable memory range of up to 64K bytes
- "Ready" input
- Direct memory access capability
- Bus compatible with MC6800
- Choice of external or on-board clocks
- 1MHz, 2MHz, 3MHz and 4MHz versions
- On-chip clock options
 - External single clock input
 - Crystal time base input
- Pipeline architecture

General Description

The UM6502/UM6502E/UM6507/UM6512 microprocessors are totally software compatible with one another. These products provide a selection of addressable memory range, interrupt input options and on-chip clock oscillators and drivers. The UM6502/UM6502E/UM6507 on-chip clock versions are aimed at high

performance, low cost applications where single phase inputs or crystals provide the time base. The UM6512 external clock version is geared for the multi-processor system applications where maximum timing control is mandatory. These products are bus compatible with the MC6800 product offering.

Pin Configurations

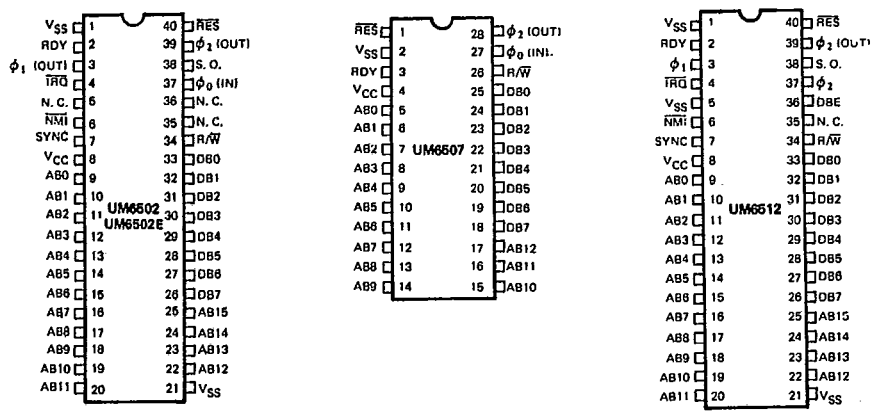



T-49-17-06

UM6502E

Absolute Maximum Ratings*

Supply Voltage V_{CC} -0.3 to +7.0V
 Input Voltage V_{in} -0.3 to +7.0V
 Operating Temperature T_A 0 to 70°C
 Storage Temperature T_{STG} -55 to +150°C

***Comments**

Stresses above those listed under "Absolute Maximum Ratings" may cause permanent damage to the device. These are stress ratings only. Functional operation of this device at these or any other conditions above those indicated in the operational sections of this specification is not implied and exposure to absolute maximum rating conditions for extended periods may affect device reliability.

Microprocessor

D.C. Electrical Characteristics ($V_{CC} = 5.0V \pm 5\%$, $T_A = 0 - 70^\circ C$)
 (ϕ_1, ϕ_2 applies to UM6512, $\phi_0(in)$ applies to UM6502/UM6502E/UM6507)

Symbol	Characteristics	Min.	Max.	Unit	
V_{IH}	Input High Voltage				
	Logic and ϕ_0 (in) for UM6502/UM6502E/UM6507 } { 1, 2, 3 MHz	+ 2.0	V_{CC}	V	
	ϕ_1 and ϕ_2 only for UM6512 } { 4 MHz	+ 3.3	V_{CC}	V	
	All Speeds	$V_{CC} - 0.5$	$V_{CC} + 0.25$	V	
V_{IL}	Input Low Voltage				
	Logic, ϕ_0 (in) (UM6502/UM6502E/UM6507) ϕ_1, ϕ_2 (UM6512)	-0.3 -0.3	+0.8 +0.2	V	
I_{IL}	Input Loading ($V_{in} = 0V, V_{CC} = 5.25V$) RDY, S.O.	-10	-300	μA	
I_{in}	Input Leakage Current ($V_{in} = 0$ to 5.25 V, $V_{CC} = 0$)	-	2.5	μA	
	Logic (Excl. RDY, S.O.)	-	100	μA	
	ϕ_1, ϕ_2 (UM6512)	-	10.0	μA	
	ϕ_0 (in) (UM6502/UM6502E/UM6507)	-			
I_{TSI}	Three-State (Off State) Input Current ($V_{in} = 0.4$ to 2.4 V, $V_{CC} = 5.25V$) DB0-DB7	-	± 10	μA	
V_{OH}	Output High Voltage ($I_{LOAD} = -100 \mu A_{dc}, V_{CC} = 4.75V$) 1, 2 MHz SYNC, DB0-DB7, AB0-AB15, R/W	2.4	-	V	
V_{OL}	Output Low Voltage ($I_{LOAD} = 1.6mA_{dc}, V_{CC} = 4.75V$) 1, 2 MHz SYNC, DB0-DB7, AB0-AB15, R/W	-	0.4	V	
P_D	Power Dissipation 1MHz and 2 MHz ($V_{CC} = 5.25V$)	-	700	mW	
C	Capacitance ($V_{in} = 0, T_A = 25^\circ C, f = 1 MHz$)				
	C_{in}	RES, NMI, RDY, TRQ, S.O., DBE DB0-DB7	-	10 15	pF
	C_{out}	AB0-AB15, R/W, SYNC	-	12	
	$C_{\phi_0}(in)$	ϕ_0 (in) (UM6502/UM6502E/UM6507)	-	15	
	C_{ϕ_1}	ϕ_1 (UM6512)	-	50	
	C_{ϕ_2}	ϕ_2 (UM6512)	-	80	



T-49-17-06

UM6502E

Block Diagram

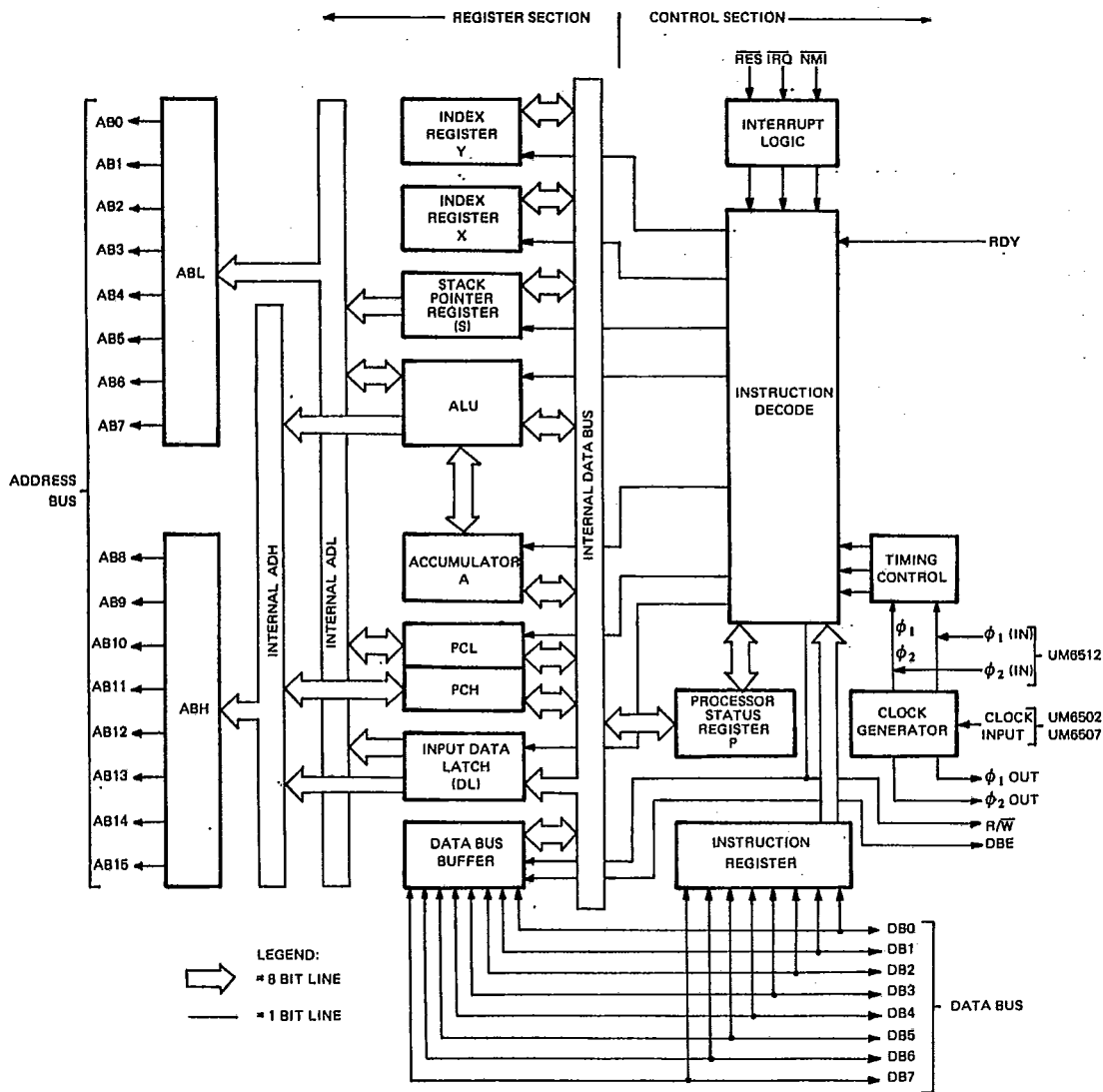

- Notes: 1. Clock generator is not included on UM6512.
 2. Addressing capability and control options vary with each product.

T-49-17-06



UM6502E

Microprocessor

Timing Waveforms

UM6502/UM6502E/
UM6507 CLOCK

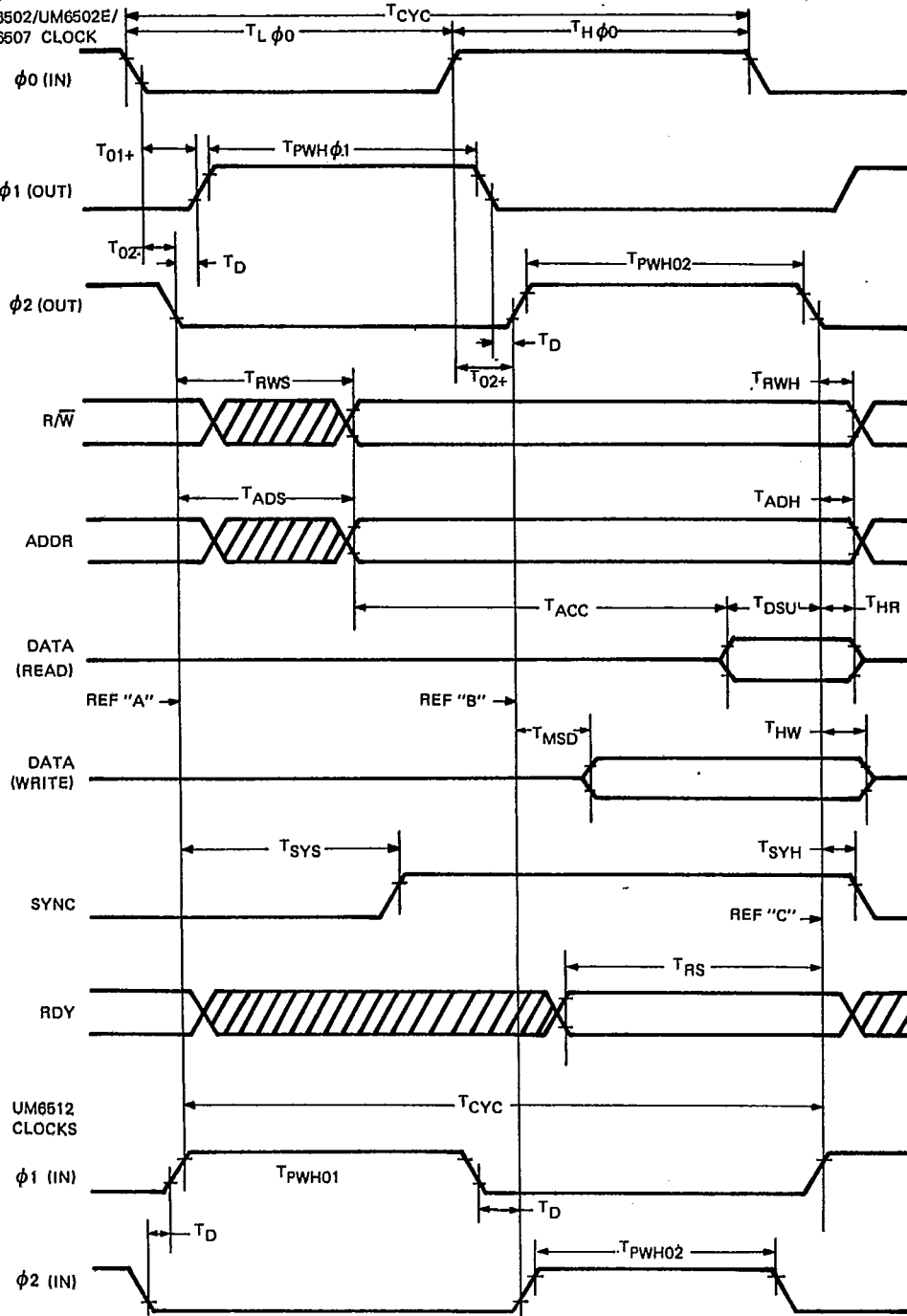



T-49-17-06

UM6502E

Dynamic Operating Characteristics ($V_{CC} = 5.0 \pm 5\%$, $T_A = 0^\circ$ to 70°C)

Parameter	Symbol	1 MHz		2 MHz		3 MHz		4 MHz		Units
		Min.	Max.	Min.	Max.	Min.	Max.	Min.	Max.	
UM6502E										
Cycle Time	T_{CYC}	1.00	40	0.50	40	0.33	40	0.25	40	μs
ϕ_0 (IN) Low Time ⁽²⁾	$T_{L\phi_0}$	480	—	240	—	160	—	110	—	ns
ϕ_0 (IN) High Time ⁽²⁾	$T_{H\phi_0}$	460	—	240	—	160	—	115	—	ns
ϕ_0 Neg to ϕ_1 Pos Delay ⁽⁵⁾	T_{01+}	10	70	—	50	—	45	—	35	ns
ϕ_0 Neg to ϕ_2 Neg Delay ⁽⁵⁾	T_{02-}	5	65	—	45	—	40	—	35	ns
ϕ_0 Pos to ϕ_1 Neg Delay ⁽⁵⁾	T_{01-}	5	65	—	45	—	40	—	30	ns
ϕ_0 Pos to ϕ_2 Pos Delay ⁽⁵⁾	T_{02+}	15	75	—	45	—	45	—	35	ns
ϕ_0 (IN) Rise and Fall Time ⁽¹⁾	T_{RO}, T_{FO}	0	30	—	20	—	15	—	10	ns
ϕ_1 (OUT), Pulse Width	$T_{PWH\phi_1}$	$T_{L\phi_0-20}$	$T_{L\phi_0}$	$T_{L\phi_0-20}$	$T_{L\phi_0}$	$T_{L\phi_0-20}$	$T_{L\phi_0}$	$T_{L\phi_0-20}$	$T_{L\phi_0}$	ns
ϕ_2 (OUT), Pulse Width	$T_{PWH\phi_2}$	$T_{L\phi_0-40}$	$T_{L\phi_0-10}$	$T_{L\phi_0-40}$	$T_{L\phi_0-40}$	$T_{L\phi_0-40}$	$T_{L\phi_0-40}$	$T_{L\phi_0-40}$	$T_{L\phi_0-10}$	ns
Delay Between ϕ_1 and ϕ_2	T_D	5	—	5	—	5	—	5	—	ns
ϕ_1 and ϕ_2 Rise and Fall Times ^(1,3)	T_R, T_F	—	25	—	25	—	15	—	15	ns
UM6502E										
R/W Setup Time	T_{RWS}	—	125	—	100	—	75	—	60	ns
R/W Hold Time	T_{RWH}	30	—	30	—	15	—	15	—	ns
Address Setup Time	T_{ADS}	—	125	—	100	—	75	—	70	ns
Address Hold Time	T_{ADH}	30	—	30	—	15	—	15	—	ns
Read Access Time	T_{ACC}	—	1000-225	—	500-150	—	330-115	—	250-105	ns
Read Data Setup Time	T_{DSU}	100	—	50	—	40	—	35	—	ns
Read Data Hold Time	T_{HR}	10	—	10	—	10	—	10	—	ns
Write Data Setup Time	T_{MDS}	20	175	—	100	—	75	—	60	ns
Write Data Hold Time	T_{HW}	60	—	60	—	30	—	30	—	ns
Sync Setup Time	T_{SYS}	—	125	—	100	—	75	—	60	ns
Sync Hold Time	T_{SYH}	30	—	30	—	15	—	15	—	ns
RDY Setup Time ⁽⁴⁾	T_{RS}	200	—	150	—	120	—	120	—	ns
UM6512										
Cycle Time	T_{CYC}	1.00	40	0.50	40	0.33	40	0.25	40	μs
ϕ_1 Pulse Width	$T_{PWH\phi_1}$	430	—	215	—	150	—	—	—	ns
ϕ_2 Pulse Width	$T_{PWH\phi_2}$	470	—	235	—	160	—	—	—	ns
Delay Between ϕ_1 and ϕ_2	T_D	0	—	0	—	0	—	—	—	ns
ϕ_1 and ϕ_2 Rise and Fall Times ⁽¹⁾	T_R, T_F	0	25	0	20	0	15	—	—	ns

(Cont.)



T-49-17-06

UM6502E

Microprocessor

Parameter	Symbol	1 MHz		2 MHz		3 MHz		4 MHz		Units
		Min.	Max.	Min.	Max.	Min.	Max.	Min.	Max.	
UM6502/UM6507										
Cycle Time	T _{CYC}	1.00	40	0.50	40	0.33	40	0.25	40	μs
φ ₁ (IN) Low Time ⁽²⁾	T _{Lφ₁}	480	—	240	—	160	—	110	—	ns
φ ₀ (IN) High Time ⁽²⁾	T _{Hφ₀}	460	—	240	—	160	—	115	—	ns
φ ₀ Neg to φ ₁ Pos Delay ⁽⁵⁾	T _{O1+}	10	70	10	70	10	70	10	70	ns
φ ₀ Neg to φ ₂ Neg Delay ⁽⁵⁾	T _{O2-}	5	65	5	65	5	65	5	65	ns
φ ₀ Pos to φ ₁ Neg Delay ⁽⁵⁾	T _{O1-}	5	65	5	65	5	65	5	65	ns
φ ₀ Pos to φ ₂ Pos Delay ⁽⁵⁾	T _{O2+}	15	75	15	75	15	75	15	75	ns
φ ₀ (IN) Rise and Fall Time ⁽¹⁾	T _{RO, TFO}	0	30	0	20	0	15	0	10	ns
φ ₁ (OUT), Pulse Width	T _{PWHφ₁}	T _{Lφ₀-20}	T _{Lφ₀}	T _{Lφ₀-20}	T _{Lφ₀}	T _{Lφ₀-20}	T _{Lφ₀}	T _{Lφ₀-20}	T _{Lφ₀}	ns
φ ₂ (OUT), Pulse Width	T _{PWHφ₂}	T _{Lφ₀-40}	T _{Lφ₀-10}	T _{Lφ₀-40}	T _{Lφ₀-40}	T _{Lφ₀-40}	T _{Lφ₀-10}	T _{Lφ₀-40}	T _{Lφ₀-10}	ns
Delay Between φ ₁ and φ ₂	T _D	5	—	5	—	5	—	5	—	ns
φ ₁ and φ ₂ Rise and Fall Times ^(1, 3)	T _{R, TF}	—	25	—	25	—	15	—	15	ns
UM6502/UM6507/UM6512										
R/W Setup Time	T _{RWS}	—	225	—	140	—	110	—	90	ns
R/W Hold Time	T _{RWH}	30	—	30	—	15	—	10	—	ns
Address Setup Time	T _{ADS}	—	225	—	140	—	110	—	90	ns
Address Hold Time	T _{ADH}	30	—	30	—	15	—	10	—	ns
Read Access Time	T _{ACC}	—	650	—	310	—	170	—	110	ns
Read Data Setup Time	T _{DSU}	100	—	50	—	50	—	50	—	ns
Read Data Hold Time	T _{HR}	10	—	10	—	10	—	10	—	ns
Write Data Setup Time	T _{MDS}	20	175	20	100	20	75	—	70	ns
Write Data Hold Time	T _{HW}	60	150	60	150	30	130	20	—	ns
Sync Setup Time	T _{SYH}	—	350	—	175	—	100	—	90	ns
Sync Hold Time	T _{SYH}	30	—	30	—	15	—	15	—	ns
RDY Setup Time ⁽⁴⁾	T _{RS}	200	—	200	—	150	—	120	—	ns

Notes:

1. Measured between 10% and 90% points.
2. Measured at 50% points.
3. Load = 1 TTL load + 30 pF.
4. RDY must never switch states within T_{RS} to end of φ₁.
5. Load = 100 pF.
6. The 2 MHz devices are identified by an "A" suffix.
7. The 3 MHz devices are identified by an "B" suffix.
8. The 4 MHz devices are identified by an "C" suffix.

Timing Diagram Note:

Because the clock generation for the UM6502/UM6502E/UM6507 and UM6512 is different, the two clock timing sections are referenced to the main timing diagram by three reference lines marked REF 'A', REF 'B' and REF 'C'. Reference between the two sets of clock timings is without meaning. Timing parameters referring to these lines and scale variations in the diagrams are of no consequence.



T-49-17-06

UM6502E

PIN FUNCTIONS

Clocks (ϕ_1 , ϕ_2)

The UM6512 requires a two phase non-overlapping clock that runs at the V_{CC} voltage level.

The UM6502/UM6502E/UM6507 clocks are supplied with an internal clock generator. The frequency of these clocks is externally controlled. Clock generator circuits are shown elsewhere in this data sheet.

Address Bus (AB0-AB15)

(See sections on each microprocessor for respective address lines on those devices.)

These outputs are TTL compatible, capable of driving one standard TTL load and 130 pF.

Data Bus (DB0-DB7)

Eight pins are used for the data bus. This is a bi-directional bus, transferring data to and from the device and peripherals. The outputs are three-state buffers, capable of driving one standard TTL load and 130 pF.

Data Bus Enable (DBE)

This TTL compatible input allows external control of the three-state data output buffers and will enable the microprocessor bus driver when in the high state. In normal operation DBE would be driven by the phase two (ϕ_2) clock, thus allowing data output from microprocessor only during ϕ_2 . During the read cycle, the data bus drivers are internally disabled, becoming essentially an open circuit. To disable data bus drivers externally, DBE should be held low. This signal is available on the UM6512 only.

Ready (RDY)

This input signal allows the user to halt the microprocessor on all cycles except write cycles. A negative transition to the low state during or coincident with phase one, (ϕ_1) will halt the microprocessor with the output address lines reflecting the current address being fetched. This condition will remain through a subsequent phase two (ϕ_2) in which the Ready signal is low. This feature allows microprocessor interfacing with low speed PROMS as well as fast (max. 2 cycle) Direct Memory Access (DMA). If ready is low during a write cycle, it is ignored until the following read operation. Ready transitions must not be permitted during ϕ_2 time.

Interrupt Request (\overline{IRQ})

This TTL level input requests that an interrupt sequence begin within the microprocessor. The microprocessor will complete the current instruction being executed before recognizing the request. At the time, the interrupt mask bit in the Status Code Register will be examined. If the interrupt mask flag is not set, the microprocessor will begin an interrupt sequence. The Program Counter and Processor Status Register are stored in the stack. The microprocessor will then set the interrupt mask flag high so that no further interrupts may occur. At the end of this cycle, the program counter low will be loaded from address FFFE, and program counter high from location FFFF, therefore transferring program control to the memory vector located at these addresses. The RDY signal must be in the high state for any interrupt to be recognized. A 3K Ω

external resistor should be used for proper wire-OR operation.

Non-Maskable Interrupt (\overline{NMI})

A negative going transition on this input requests that a non-maskable interrupt sequence be generated within the microprocessor.

\overline{NMI} is an unconditional interrupt. Following completion of the current instruction, the sequence of operations defined for \overline{IRQ} will be performed, regardless of the state interrupt mask flag. The vector addresses loaded into the program counter, low and high, are locations FFFA and FFFB respectively, thereby transferring program control to the memory vector located at these addresses. The instructions loaded at these locations cause the microprocessor to branch to a non-maskable interrupt routine in memory.

\overline{NMI} also requires an external 3K Ω resistor to V_{CC} for proper wire-OR operations.

Inputs \overline{IRQ} and \overline{NMI} are hardware interrupts lines that are sampled during ϕ_2 (phase 2) and will begin the appropriate interrupt routine on the ϕ_1 (phase 1) following the completion of the current instruction.

Set Overflow Flag (S. O.)

A NEGATIVE going edge on this input sets the overflow bit in the Status Code Register. This signal is sampled on the trailing edge of ϕ_1 .

SYNC

This output line is provided to identify those cycles in which the microprocessor is doing an OP CODE fetch. The SYNC line goes high during ϕ_1 of an OP CODE fetch and stays high for the remainder of that cycle. If the RDY line is pulled low during the ϕ_1 clock pulse in which SYNC went high, the processor will stop in its current state and will remain in the state until the RDY line goes high. In this manner, the SYNC signal can be used to control RDY to cause single instruction execution.

Reset (\overline{RES})

This input is used to reset or start the microprocessor from a power down condition. During the time that this line is held low, writing to or from the microprocessor is inhibited. When a positive edge is detected on the input, the microprocessor will immediately begin the reset sequence.

After a system initialization time of six clock cycles, the mask interrupt flag will be set and the microprocessor will load the program counter from the memory vector locations FFFC and FFFD. This is the start location for program control.

After V_{CC} reaches 4.75 volts in a power up routine, reset must be held low for at least two clock cycles. At this time the R/ \overline{W} and SYNC signal will become valid. When the reset signal goes high following these two clock cycles, the microprocessor will proceed with the normal reset procedure detailed above.

Read/Write (R/ \overline{W})

This output signal is used to control the direction of data transfers between the processor and other circuits on the data bus. A high level on R/ \overline{W} signifies data into the processor; a low is for the data transfer out of the processor.



T-49-17-06

UM6502E

PROGRAMMING CHARACTERISTICS

INSTRUCTION SET – ALPHABETIC SEQUENCE

ADC Add Memory to Accumulator with Carry	LDA Load Accumulator with Memory
AND "AND" Memory with Accumulator	LDX Load Index X with Memory
ASL Shift left One Bit (Memory or Accumulator)	LDY Load Index Y with Memory
BCC Branch on Carry Clear	LSR Shift One Bit Right (Memory or Accumulator)
BCS Branch on Carry Set.	NOP No Operation
BEQ Branch on Result Zero	ORA "OR" Memory with Accumulator
BIT Test Bits in Memory with Accumulator	PHA Push Accumulator on Stack
BMI Branch on Result Minus	PHP Push Processor Status on Stack
BNE Branch on Result not Zero	PLA Pull Accumulator from Stack
BPL Branch on Result Plus	PLP Pull Processor Status from Stack
BNK Force Break	ROL Rotate One Bit Left (Memory or Accumulator)
BVC Branch on Overflow Clear	ROR Rotate One Bit Right (Memory or Accumulator)
BVS Branch on Overflow Set	RTI Return from Interrupt
CLC Clear Carry Flag	RTS Return from Subroutine
CLD Clear Decimal Mode	SBC Subtract Memory from Accumulator with Borrow
CLI Clear Interrupt Disable Bit	SEC Set Carry Flag
CLV Clear Overflow Flag	SED Set Decimal Mode
CMP Compare Memory and Accumulator	SEI Set Interrupt Disable Status
CPX Compare Memory and Index X	STA Store Accumulator in Memory
CPY Compare Memory and Index Y	STX Store Index X in Memory
DEC Decrement Memory by One	STY Store Index Y in Memory
DEX Decrement Index X by One	TAX Transfer Accumulator to Index X
DEY Decrement Index Y by One	TAY Transfer Accumulator to Index Y
EOR "Exclusive-or" Memory with Accumulator	TSX Transfer Stack Pointer to Index X
INC Increment Memory by One	TXA Transfer Index X to Accumulator
INX Increment Index X by One	TXS Transfer Index X to Stack Pointer
INY Increment Index Y by One	TYA Transfer Index Y to Accumulator
JMP Jump to New Location	
JSR Jump to New Location Saving Return Address	

Microprocessor

ADDRESSING MODES

Accumulator Addressing

This form of addressing is represented with a one byte instruction, implying an operation on the accumulator.

Immediate Addressing

In immediate addressing, the operand is contained in the second byte of the instruction, with no further memory addressing required.

Absolute Addressing

In absolute addressing, the second byte of the instruction specifies the eight low order bits of the effective address while the third byte specifies the eight high order bits. Thus, the absolute addressing mode allows access to the entire 65K bytes of addressable memory.

Zero Page Addressing

The zero page instructions allow for shorter code and execution times by only fetching the second byte of the

instruction and assuming a zero high address byte. careful use of the zero page can result in significant increase in code efficiency.

Indexed Zero Page Addressing – (X, Y indexing)

This form of addressing is used in conjunction with the index register and is referred to as "Zero Page, "X" or "Zero Page, Y." The effective address is calculated by adding the second byte to the contents of the index register. Since this is a form of "Zero Page" addressing, the content of the second byte references a location in page zero. Additionally due to the "Zero Page" addressing nature of this mode, no carry is added to the high order 8 bits of memory and crossing of page boundaries does not occur.

Indexed Absolute Addressing – (X, Y indexing)

This form of addressing is used in conjunction with X and Y index registers and is referred to as "Absolute,



T-49-17-06

UM6502E

X," and "Absolute, Y." The effective address is formed by adding the contents of X or Y to the address contained in the second and third bytes of the instruction. This mode allows the index register to contain the index or count value and the instruction to contain the base address. This type of indexing allows any location referencing and the index to modify multiple fields resulting in reduced coding and execution time.

Implied Addressing

In the implied addressing mode, the address containing the operand is implicitly stated in the operation code of the instruction.

Relative Addressing

Relative addressing is used only with branch instructions and establishes a destination for the conditional branch.

The second byte of the instruction becomes the operand which is an "Offset" added to the contents of the lower eight bits of the program counter when the counter is set at the next instruction. The range of the offset is -128 to + 127 bytes from the next instruction.

Indexed Indirect Addressing

In indexed indirect addressing (referred to as [Indirect, X]), the second byte of the instruction is added to the contents of the X index register, discarding the carry.

The result of this addition points to a memory location on page zero whose content is the low order eight bits of the effective address. The next memory location in page zero contains the high order eight bits of the effective address. Both memory locations specifying the high and low order bytes of the effective address must be in page zero.

Indirect Indexed Addressing

In indirect indexed addressing (referred to as [Indirect, Y]), the second byte of the instruction points to a memory location in page zero. The content of this memory location is added to the contents of the Y index register, the result being the low order eight bits of the effective address. The carry from this addition is added to the contents of the next page zero memory location, the result being the high order eight bits of the effective address.

Absolute Indirect

The second byte of the instruction contains the low order eight bits of a memory location. The high order eight bits of that memory location is contained in the third byte of the instruction. The content of the fully specified memory location is the low order byte of the effective address. The next memory location contains the high order byte of the effective address which is loaded into the sixteen bits of the program counter.

PROGRAMMING CHARACTERISTICS

PROGRAMMING MODEL

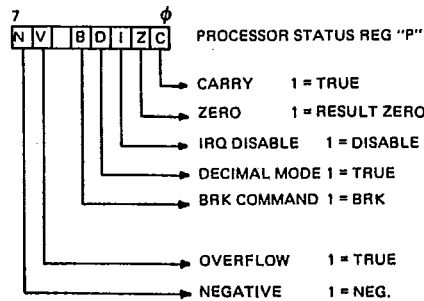
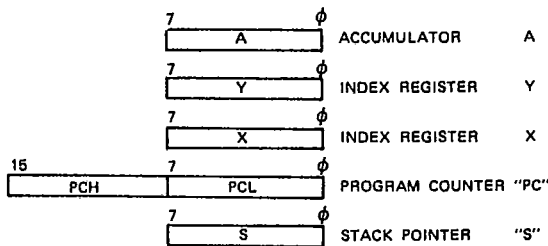



T-49-17-06

UM6502E

Clock Generation Circuits*

*Crystals used are CTS Knight MP Series or equivalents. (Series Mode)

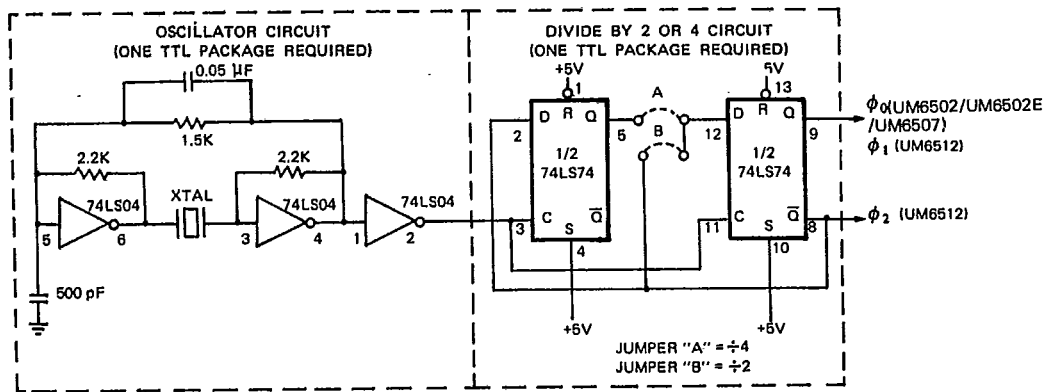

Microprocessor

Crystal Frequency	Output Frequency	
	$\div 2$	$\div 4$
3.679645 MHz	1.7897 MHz	0.894886 MHz
4.194304 MHz	2.097152 MHz	1.048576 MHz

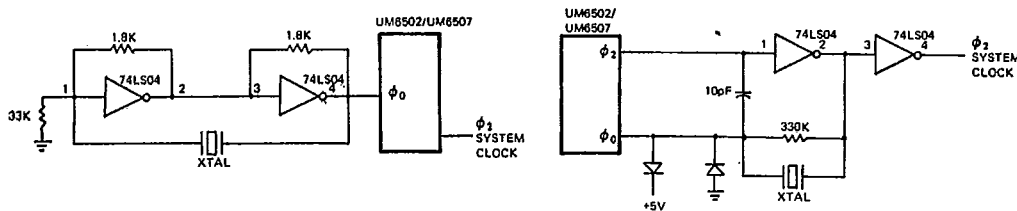

Crystal Application Circuit

Ordering Information

1 MHz	2 MHz	3 MHz	4 MHz
UM6502	UM6502A	UM6502B	UM6502C
UM6502E	UM6502AE	UM6502BE	UM6502CE
UM6507	-	-	-
UM6512	UM6512A	UM6512B	UM6512C

Part Number	Clocks	Pins	IRO	NMI	RYD	Addressing
UM6502	On-Chip	40	✓	✓	✓	64K
UM6502E	On-Chip	40	✓	✓	✓	64K
UM6507	On-Chip	28	✓	✓	✓	8K
UM6512	External	40	✓	✓	✓	64K



T-49-17-06

UM6502E

Instruction Set

INSTRUCTIONS		IMME-DIATE			ABSO-LUTE			ZERO-PAGE			ACCUM			IMPLIED			(IND. X)			(IND. Y)				
MNEMONIC	OPERATION	OP	n	#	OP	n	#	OP	n	#	OP	n	#	OP	n	#	OP	n	#	OP	n	#		
A A A B B B	D N S C C C	C D L C S	A + M + C → A (4) (1) A ← M → A (1) C ← [7] 0 ← 0 BRANCH ON C = 0 (2) BRANCH ON C = 1 (2)	69 29	2 2	2 2	6D 2D 0E	4 4 6	3 3 3	65 25 06	3 3 5	2 2 2					61 21	6 6	2 2	71 31	6 5	2 2		
B B B B B	E I M N P	Q T I E L	BRANCH ON Z = 1 (2) A ← M BRANCH ON N = 1 (2) BRANCH ON Z = 0 (2) BRANCH ON N = 0 (2)				2C	4	3	24	3	2												
B B B C C	R V V L L	K C S C D	BREAK BRANCH ON V = 0 (2) BRANCH ON V = 1 (2) 0 → C 0 → D											00 18 D8	7 2 2	1 2 1								
C C C C C	L L M P P	I V P X Y	0 → I 0 → V A - M X - M Y - M	C9 E0 C0	2 2 2	2 2 2	CD EC CC	4 4 4	3 3 3	C5 E4 C4	3 3 3	2 2 2					C1	6	2	D1	5	2		
D D D E I	E E E Y R	C X Y R	M - 1 → M X - 1 → X Y - 1 → Y AVM → A (1) M + 1 → M	49	2	2	CE 4D EE	6 4 6	3 3 3	C6 45 E6	6 3 5	2 2 2		CA 88	2 2	1 1			41	6	2	51	5	2
I J J L S D R A	N M P P D R A	X Y R A	X + 1 → X Y + 1 → Y JUMP TO NEW LOC JUMP SUB M → A (1)	A9	2	2	4C 20 AD	3 6 4	3 3 3	A5	3	2		E8 C8	2 2	1 1			A1	6	2	B1	5	2
L L L N O R A	D D S O R P A	X Y R P A	M → X (1) M → Y (1) 0 → [7] 0 → C NO OPERATION AVM → A	A2 A0	2 2	2 2	AE AC 4E	4 4 6	3 3 3	A6 A4 46	3 3 5	2 2 2	4A	2	1	EA	2	1	01	6	2	11	5	2
P P P P R	H H L L P R	A P A P L	A → MS S - 1 → S P → MS S - 1 → S S + 1 → S MS → A S + 1 → S MS → P ← [7] 0 ← [C] ←				2E	6	3	28	5	2	2A	2	1	48 08 68 28	3 3 4 4	1 2 1 1						
R R R S S S	O T T B S E	R I S C D	[C] → [7] 0 → [7] 1 RTRN INT RTRN SUB A - M - C → A (1) 1 → C 1 → D	E9	2	2	6E ED	6 4	3 3	66 E5	6 3	2 2	6A	2	1	40 60 38 F8	6 6 2 2	1 1 1 1	E1	6	2	F1	5	2
S S S T T A X	E T T Y A X	I A X Y A X	1 → I A → M X → M Y → M A → X				8D 8E 8C	4 4 4	3 3 3	85 86 84	3 3 3	2 2 2		78 AA	2 2	1 1			81	6	2	91	6	2
T T T T T Y A	A X X S A Y	A X A S A Y	A → Y S → X X → A X → S Y → A											A8 BA 8A 9A 98	2 2 2 2 2	1 1 1 1 1								

- (1) ADD 1 TO N IF PAGE BOUNDARY IS CROSSED
- (2) ADD 1 TO N IF BRANCH OCCURS TO SAME PAGE
ADD 2 TO N IF BRANCH OCCURS TO DIFFERENT PAGE
- (3) CARRY NOT = BORROW
- (4) IF IN DECIMAL MODE Z FLAG IS INVALID
ACCUMULATOR MUST BE CHECKED FOR ZERO RESULT

T-49-17-06



UM6502E

Z PAGE. X			ABS. X			ABS. Y			RELATIVE			INDIRECT			Z PAGE. Y			PROCESSOR STATUS CODES										
OP	n	#	OP	n	#	OP	n	#	OP	n	#	OP	n	#	OP	n	#	7	6	5	4	3	2	1	0	MNEMONIC		
																		N	V	.	B	D	I	Z	C	A	D	C
76 35 16	4 4 6	2 2 2	7D 3D 1E	4 4 7	3 3 3	79 39	4 4	3 3										N	V	Z	C	A	D	C
									90 80	7 2	2 2							N	Z	C	A	D	C
									F0	2	2							M ₇	M ₆	Z	.	B	E	Q
									30 D0 10	2 2 2	2 2 2							B	E	Q	
									50 70	2 2	2 2							.	.	1	.	1	.	.	B	R	K	
																		0	.	B	R	K	
D6	4	2	DD	4	3	D9	4	3									N	0	0	.	C	L	I	
																		N	Z	C	C	L	I
D8	6	2	DE	7	3													N	Z	.	D	E	C
55 F6	4 6	2 2	6D FE	4 7	3 3	69	4	3										N	Z	.	D	E	C
															6C	5	3	N	Z	.	I	N	X
85	4	2	8D	4	3	89	4	3										N	Z	.	I	N	X
																		N	Z	.	I	N	X
84 56 15	4 6 4	2 2 2	BC 5E 1D	4 7 4	3 3 3	BE	4	3							86	4	2	N	Z	.	L	D	X
																		N	Z	.	L	D	X
																		N	Z	.	L	D	X
36	6	2	3E	7	3													N	.	(RESTORED)	.	.	.	Z	.	P	H	A
																		N	.	(RESTORED)	.	.	.	Z	.	P	H	A
76 F5	6 4	2 2	7E FD	7 4	3 3													N	V	Z	(3)	R	O	R
																		N	Z	1	R	O	R
95 94	4 4	2 2	9D	5	3	99	5	3										1	.	S	E	I	
																		S	E	I	
																		N	Z	.	T	A	X
																		N	Z	.	T	A	X
																		N	Z	.	T	A	X

Microprocessor

X INDEX X + ADD M₇ MEMORY BIT 7
 Y INDEX Y - SUBTRACT M₆ MEMORY BIT 6
 A ACCUMULATOR ^ AND n NO. CYCLES
 M MEMORY PER EFFECTIVE ADDRESS V OR # NO. BYTES
 M_s MEMORY PER STACK POINTER ∨ EXCLUSIVE OR