

# The Electronic Control of Fluorescent Lamps

Prepared by **Michael Bairanzade,**  
 Power Semiconductor Applications,  
 Motorola Toulouse, France  
 Edited by **Jim Nappe and Jim Spangler**  
 Motorola USA

**Editor's Note**

The purpose of this application note is to demonstrate the BUL45 bipolar power transistor in a typical application. It is not intended to be a complete, production-ready circuit that meets all regulatory agencies' requirements. The example is centered around a European 55 watt fluorescent lamp not the standard F40T12 U.S. fluorescent lamp.

**Abstract**

The use of fluorescent lighting has been widespread in the consumer and industrial market for many years. The main advantage of fluorescent lighting is its high light output per watt compared to standard incandescent lighting.

As an example, a 32 watt fluorescent tube provides 1700 Lumens at one meter, while a 75 watt tungsten filament bulb provides only 1200 Lumens (a Lux/Watt efficiency of 53 for the fluorescent tube and 16 for the incandescent bulb).

Although the energy savings is significant, there are three major disadvantages with fluorescent lighting:

- Higher initial cost
- Discontinuous light spectrum
- Larger total package

Even with these disadvantages fluorescent lighting systems are preferred for large areas where power consumption is high.

Over the years, many different electronic approaches have been developed to control fluorescent lighting. These systems improve efficiency, extend lamp life and eliminate low-frequency flicker. All three of these advantages help to offset the initial high cost. This application note discusses the standard single lamp magnetic ballast, an electronic approach, limitations of different methods and a recently developed bipolar power transistor from Motorola that significantly improves circuit performance.

## THE STANDARD CIRCUIT

The operation of a standard fluorescent tube requires very few basic parts; ballast (inductor), glow starter and capacitor as shown Figure 1. The gas mixture enclosed in the fluorescent lamp, called a tube, is ionized by means of a high-voltage pulse applied between the two heated electrodes at each end of the tube.

During start-up, the electrodes (actually filaments) are heated when the starter switch is closed. The filaments heat the mercury vapor and the gas near the filaments. Af-

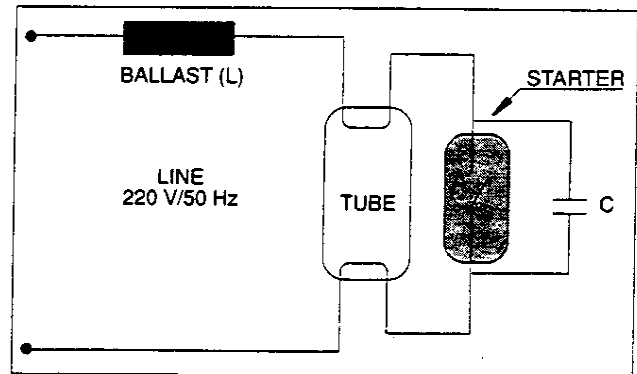

**Figure 1. Standard Fluorescent Tube Circuit**

ter approximately a second, the starter switch automatically opens and causes an inductive kick (a high-voltage spike) from the ballast that ionizes the fluorescent tube gas and drives the tube into the steady-state mode. The tube impedance decreases from near megaohms to its operating value (depending upon the tube internal characteristics, i.e., 250 - 300 ohms for an F40T12). The current in the circuit is limited by lamp impedance and ballast inductive reactance,  $L$ , in series with the power line.

The glow starter switch, commonly called the "starter", is an essential part of the fluorescent tube triggering system. The starter is a bimetallic contact enclosed in a glass envelope which is filled with a neon-based gas mixture and is normally in the open state. When line voltage is applied to the circuit, the voltage across the fluorescent tube is insufficient to ionize the cold gas fluorescent tube mixture. The voltage across the starter is sufficient to ionize the neon mixture which heats up the bimetallic contact and causes the starter switch to close. This action deionizes the starter switch gas and the bimetallic switch begins to cool down while current is flowing in the circuit, heating up the two filaments in the fluorescent tube. When the bimetallic contact cools down sufficiently the starter switch opens. This gives rise to large induced voltage across the fluorescent tube because of the rapid change in current through the ballast inductance,  $L$ . This voltage can be determined using Eq (1):

$$V = L \, di/dt \quad \text{Eq (1)}$$

Since there's no synchronization with the line frequency the starter operates on a random basis. The starter can open at any current level between zero and the maximum circuit current.



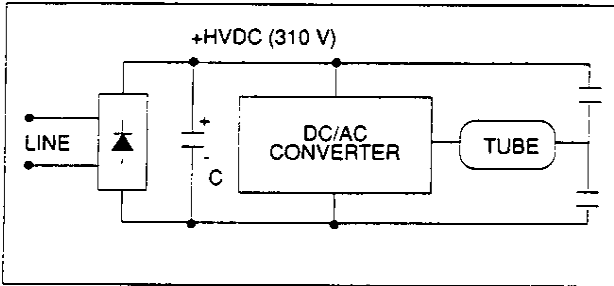

Figure 2. Electronic Ballast Schematic Diagram

If the induced voltage is too low (i.e., the starter opens at a low current level) the gas is not ionized and the tube doesn't turn ON. The start-up sequence is automatically repeated until the gas in the fluorescent tube is fully ionized. This is the flashing that often occurs at turn-on with fluorescent lamp circuits.

In this standard circuit, the gas in the fluorescent tube is extinguished and ionized again with each half-cycle of the line frequency, this is the source of the low-frequency flickering in a standard circuit. To compensate for this phenomenon, dual or multiples of two fluorescent tubes are operated with different phases. One method is to use a capacitor instead of an inductor for one of the lamps. This is called a lead-lag circuit. When these are housed in a single light fixture with a light diffuser the flickering detected by the human eye is significantly reduced.

## THE ELECTRONIC SYSTEM

The basic principle of any electronic fluorescent tube controller (often called "electronic ballast") consists of supplying the tube with a high frequency ac current above 18 kHz. The typical range is from 20 kHz to 60 kHz. This approach has three main advantages:

- Improved energy conversion ratio (light output to watts input)
- Undetectable high-frequency flicker
- Lightweight ballast assembly

The main drawback of the electronic approach is the additional complex circuitry when compared to the simple magnetic inductor ballast (see Figure 2). The following are some electronic ballast topologies that are discussed in this application note:

- Flyback inverters
- Current source resonant circuits (current fed parallel resonant)
- Voltage source resonant circuits (series resonant parallel load)

The flyback topology (see Figure 3) is not very popular because of the high-voltage transients associated with this approach which implies the use of high-voltage power transistors. Also, a flyback circuit decreases the transistor's efficiency due to the switching losses as can be seen in Figure 4. A major disadvantage to the flyback is that the

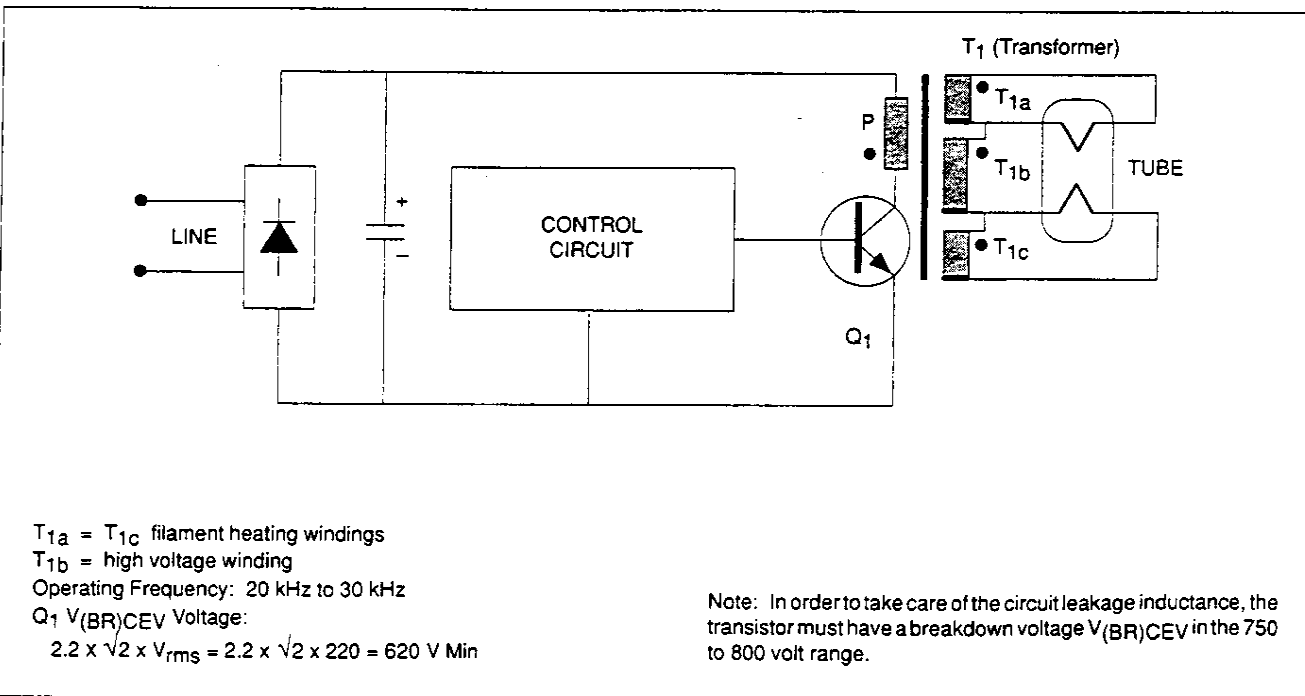

Figure 3. Flyback Topology (Typical Circuit)

waveform produced is a square wave voltage and a triangle current. The lamps want to see sine waves.

To make this circuit produce sine waves additional components are required: inductor and capacitor. When this approach has been used, the transformer has a large leakage reactance between the primary and the secondary windings. The circuit often resembles the horizontal section of a T.V. or CRT monitor with a damper diode and a resonant capacitor on both the primary and secondary side.

The current fed resonant circuit (see Figure 5) has the inherent advantage of being able to sustain, indefinitely, the open or short circuit loads. It is a higher cost approach because it requires an extra inductance called a feed

choke. The circuit is simple but requires high-voltage transistors. For additional information on this topology see the following Motorola Application Notes: Electronic Ballast (AR180) and Bipolar Transistors Excel in Off-Line Resonant Converters (AR181).

In the equivalent circuit of Figure 5,  $V_G$  is  $\pi$  times the  $V_{rms}$  of the input line. As an example, 220 times 3.1259 equals 691  $V_{rms}$  at the resonant frequency. The capacitor,  $C_1$ , is the ballast reactor or dropping element.

The voltage fed resonant topology, sometimes called series resonant (see Figure 6) is a simple circuit approach, easy to implement and without major drawbacks.

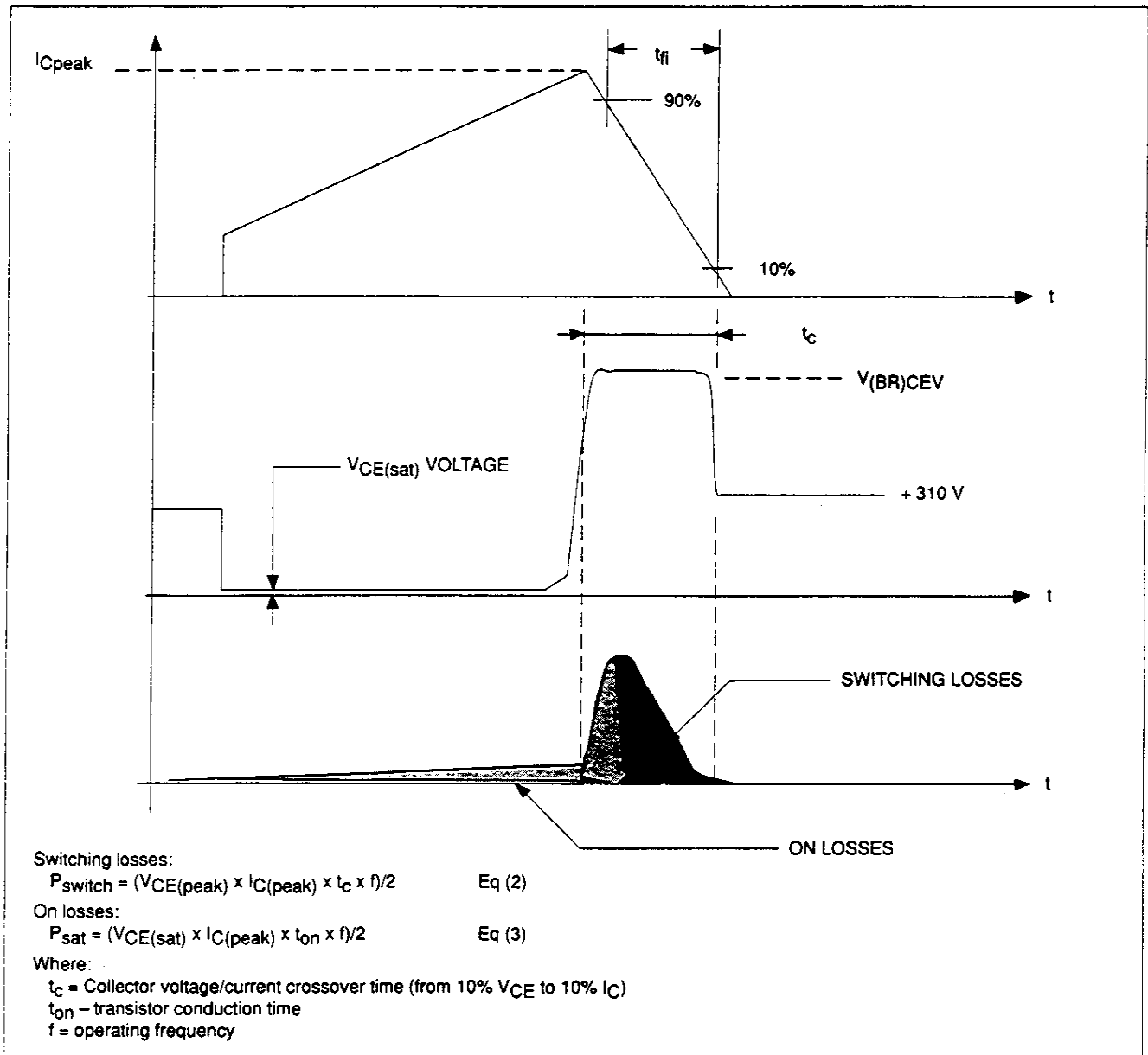

Figure 4. Losses in the Flyback Topology

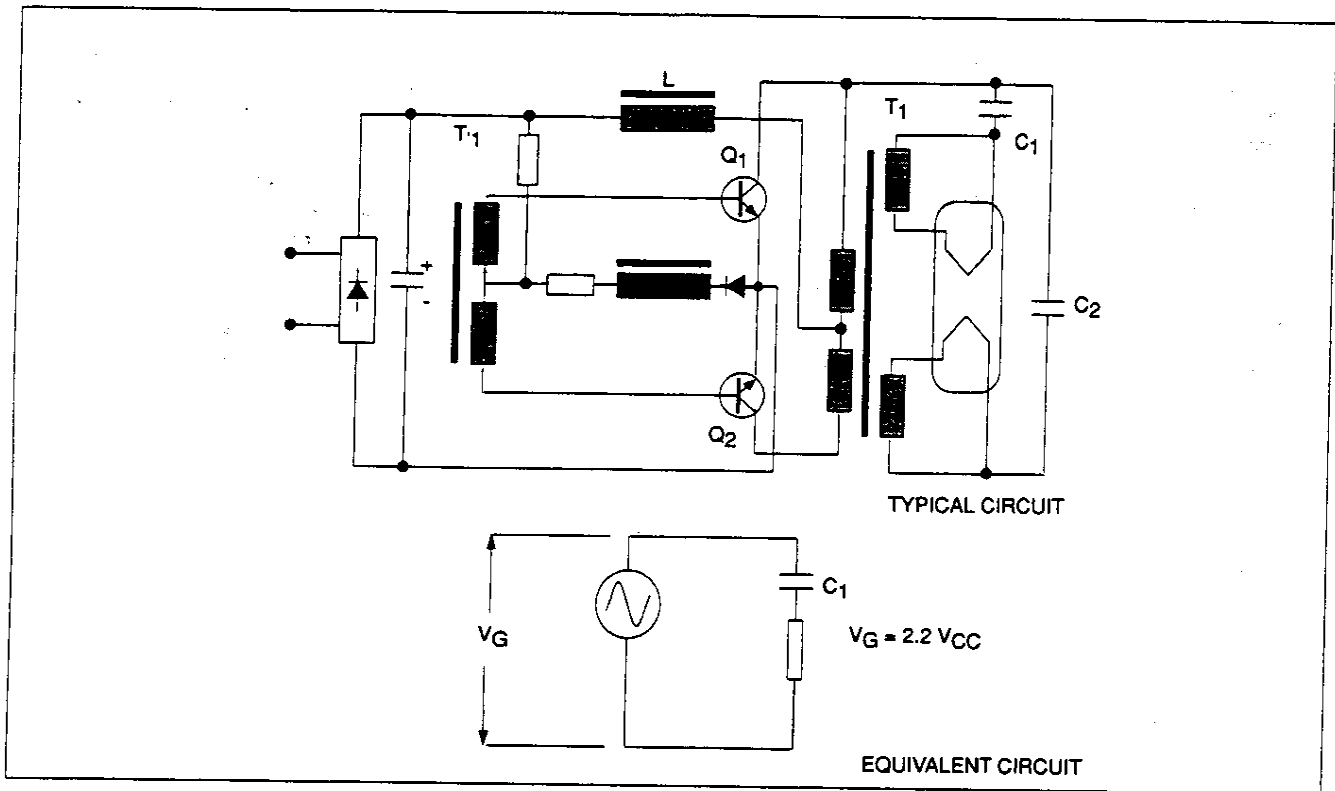

Figure 5. Typical Current Fed Resonant Circuit

Assuming a line voltage tolerance of +15%, the VCE voltage reaches 784 volts. Since the transistor's specification must include some safety margin, the transistor's breakdown voltage must be equal to or higher than

900/950 volts at a collector current of 1 ampere to 2 amperes,  $V_{(BR)CES(sus)}$ .

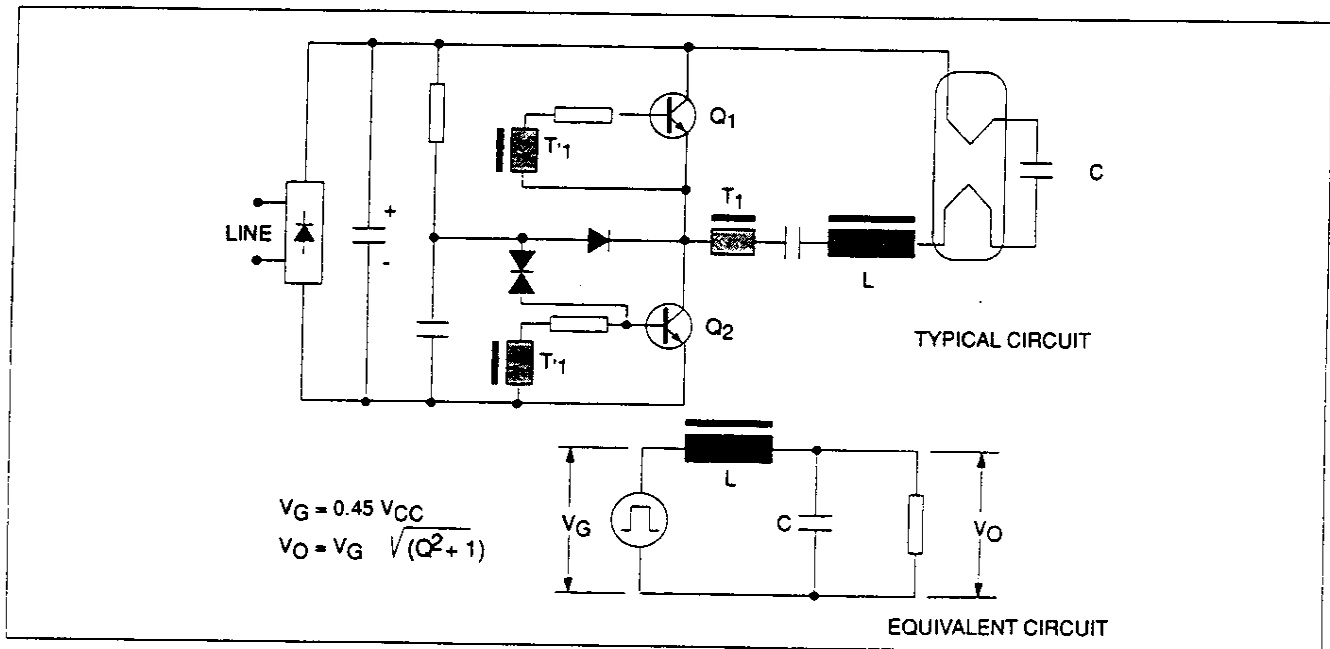

Figure 6. Typical Voltage Fed Resonant Circuit

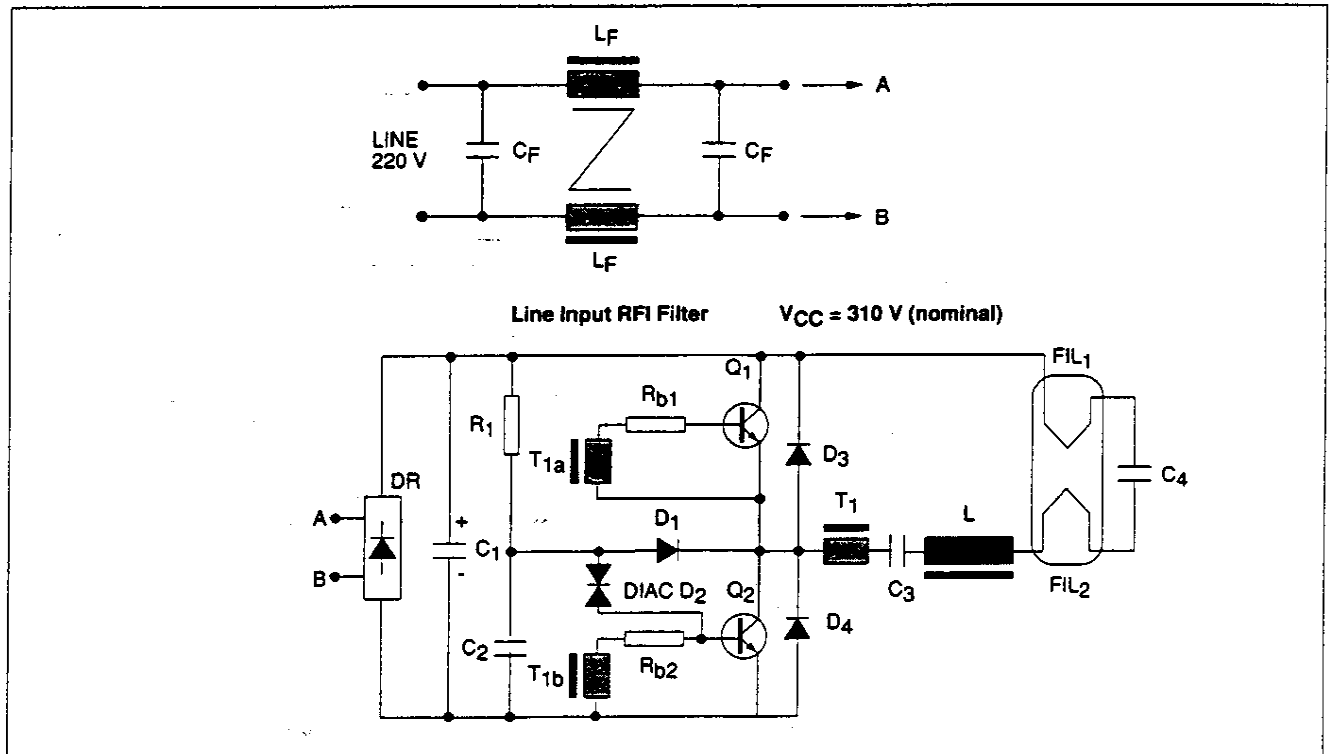

Figure 7. Typical "Voltage Fed Circuit" Schematic Diagram

## THE VOLTAGE FED RESONANT CIRCUIT

This configuration appears to be one approach used by many electronic ballast manufacturers at the present time. It is the one that will be the focus of this application note. This application note will look at the performance improvements using the BUL45 (a detailed schematic diagram is shown in Figure 7). Figure 7 will be used as the reference for the rest of this application note. Waveforms for this type of circuit are shown in Figures 8, 9 and 10.

The line voltage is rectified by DR and charges up capacitor  $C_1$ .  $C_1$  becomes the dc voltage source feeding the fluorescent tube circuit. The input filter, consisting of inductance  $L_f$  and capacitor  $C_f$ , has a dual purpose :

- Protects the circuit against line transients
- Attenuates any EMI (Electro Magnetic Interference) perturbations generated by the high-frequency source that feeds the tube

This input filter is mandatory for all industrial electronic ballasts. It must meet both the German (VDE) and U.S. (FCC and U.L.) specifications which define the maximum RFI levels, creepage distances and the filter frequency response. Details about these specifications can be found in related technical literature supplied by VDE, FCC and U.L. Each country has its own regulatory agencies.

From the basic equivalent circuit shown in Figure 6, the energy transfer from input to load is accomplished using a series resonant circuit. In the schematic diagram of Figure 7, this series resonant circuit consists of the passive components  $L$ ,  $C_3$ , and  $C_4$  in parallel with the fluorescent tube's internal impedance. When the circuit is first turned on, the fluorescent tube is deionized and appears as a high impedance. Capacitor  $C_4$  is virtually in series with  $L$  and  $C_3$  (via the tube filaments  $FIL_1$  and  $FIL_2$ ), yielding an operating point at the resonant frequency given by:

$$f_0 = 1 / 2\pi \sqrt{L (C_3 \times C_4) / (C_3 + C_4)} \quad \text{Eq (4)}$$

At resonance the large voltage generated across capacitor  $C_4$  allows the quasi-instantaneous ionization of the tube. This results in instant starting and often degrades the filaments because the filaments have not been elevated to their proper emission temperature before high voltage is applied. This initial behavior is confirmed by the oscillogram shown in Figure 8, showing the collector current of  $Q_2$  during the start-up phase. At this time the peak collector current value (2.75 amperes) is close to four times the steady-state value (0.75 amperes). It will be necessary to choose power transistors for  $Q_1$  and  $Q_2$  that can handle these high start-up current levels when operating at the unloaded resonant frequency. The current in the L/C network is limited only by the dc resistance of the circuit. See Appendix for more details.

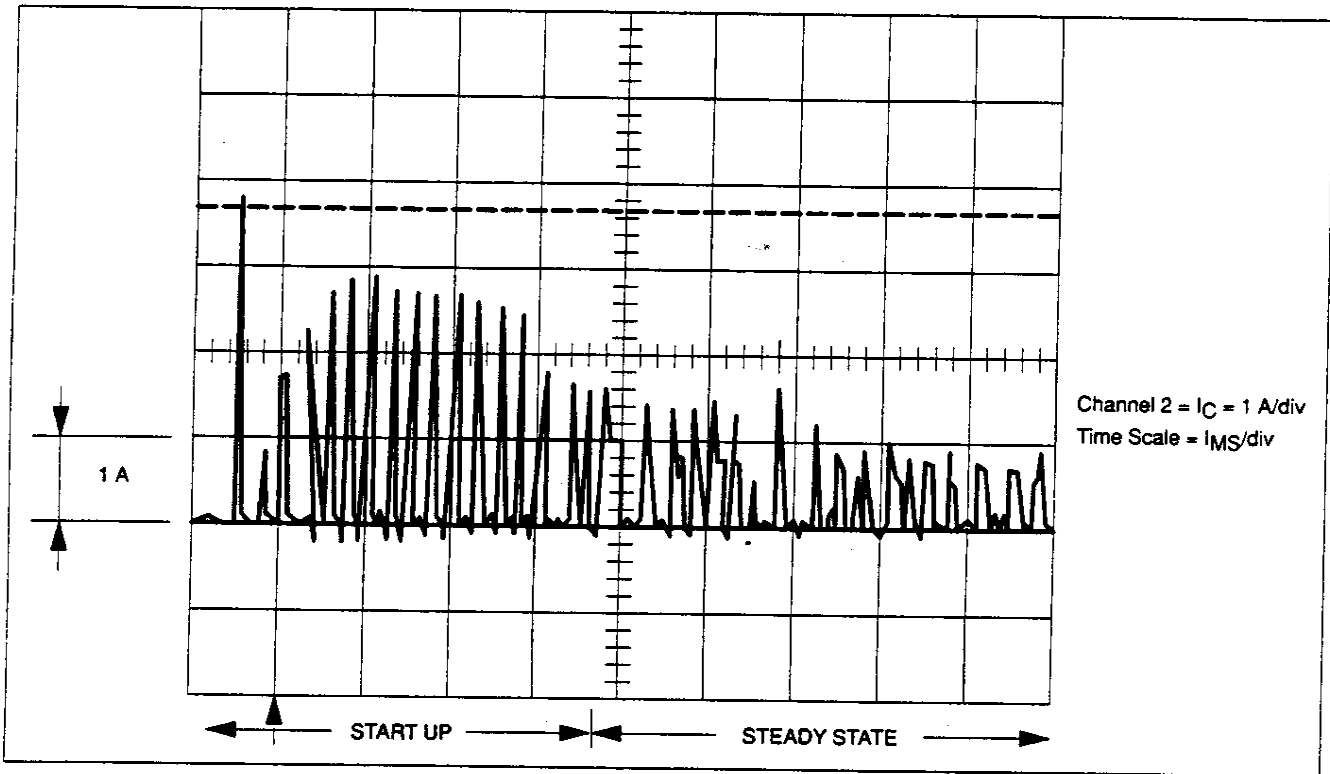

Figure 8. Start-Up Collector Current

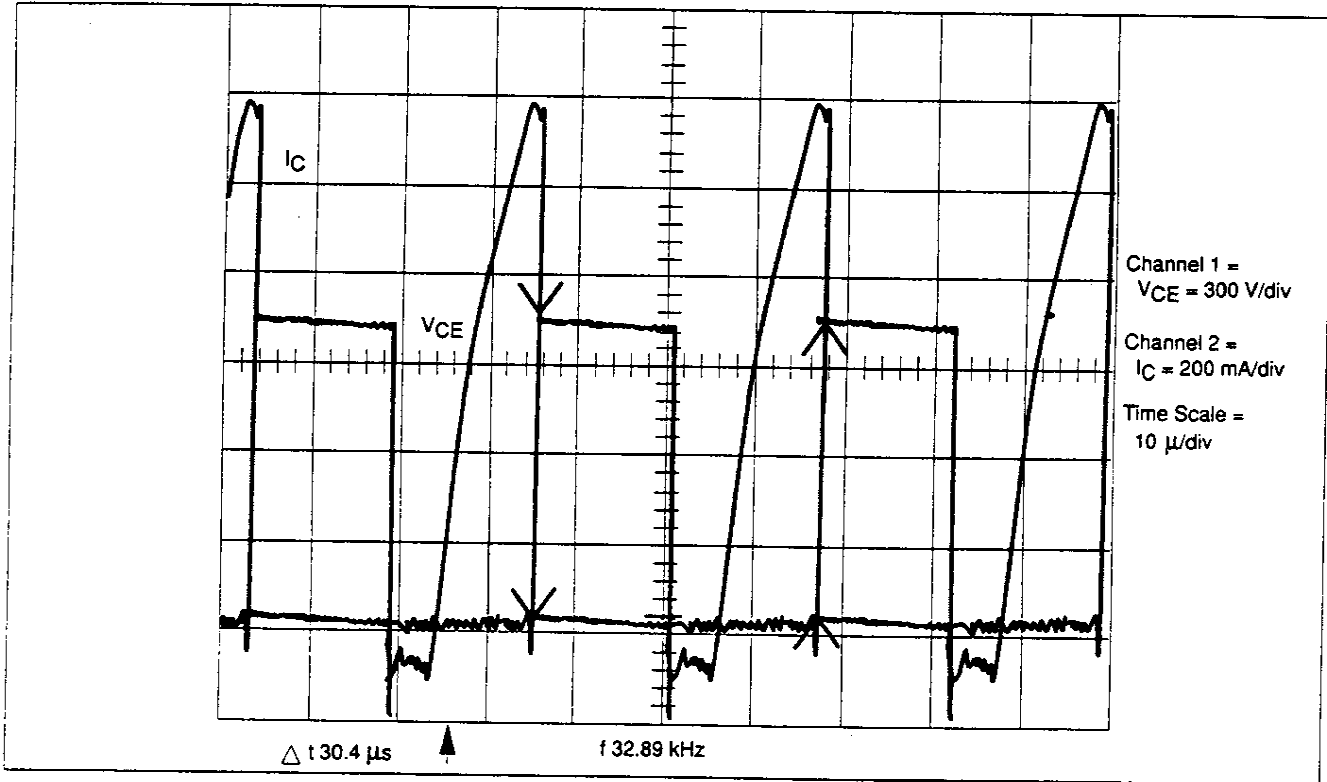

Figure 9. Steady-State Collector Current and Voltage

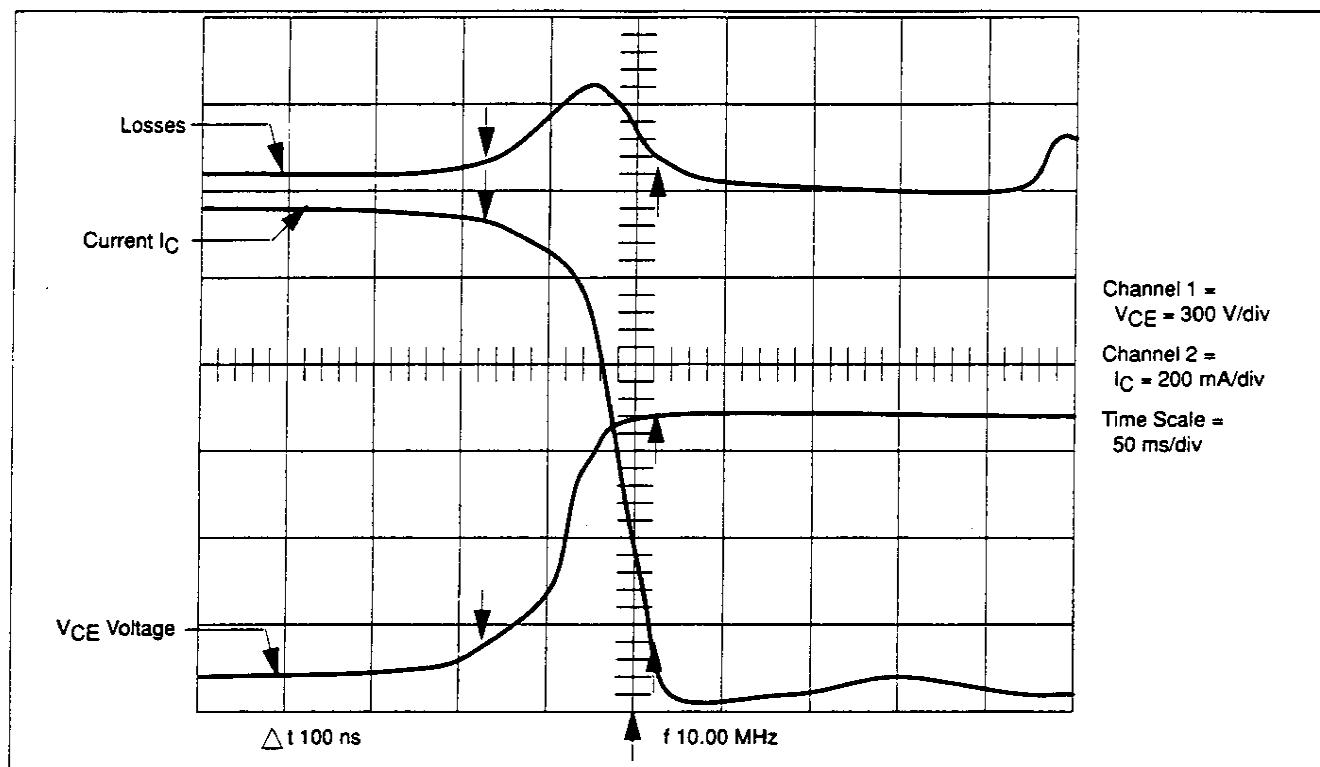

Figure 10. Steady-State Switching Losses

In the circuit in Figure 6 and Figure 7 there are two resonant capacitors in series. These are labeled  $C_3$  and  $C_4$  in Figure 7. These two capacitors help divide up the high voltage developed during the lamp starting process. If the ratio of the two capacitors is incorrect, damage to the filaments results which shortens tube life. As the dc bus voltage changes because of different countries, the ratio or size of these capacitors changes. Today there are many articles that show only one resonant capacitor that is placed across the tube in series with the filament. This approach allows resonance to be controlled over a larger range while at the same time filament current can be regulated after ionization. Capacitor  $C_4$  controls filament current while  $C_3$  controls resonance.

When the tube is fully ionized, its impedance drops to a low value. The actual value depends upon the tube characteristics, for example, approximately 300 ohms for a F40T12 U.S. lamp and 400 ohms for a 55 watt European lamp. This results in a virtual short circuit across capacitor  $C_4$ . This, in turn, shifts the resonant frequency to a value defined by  $L$  and  $C_3$ . The energy being transferred to the tube is now much lower. The voltage across the tube is very low, the tube remains ionized and on and the tube start-up sequence is now completed. In this mode of operation, voltage fed resonant converter, the losses in both the active and passive components have been minimized for the electronic ballast. This point is confirmed by the current and voltage waveforms for transistor  $Q_2$  shown in Figure 9. The top trace shows the power dissipation during switching.

The load is a 32 watt load and the peak current is 600 milliamps. Figure 8 shows the lamp start-up condition. The current settles down to just under 500 milliamps after warm-up. Figure 9 shows the steady-state current and voltage of a single transistor, BUL45. Note that there is a negative current shown in Figure 9. This is caused by the base drive toroid transformer. The current flows through the collector-base region and is not harmful. This is common in self-commuting circuits.

### CIRCUIT START UP

The oscillatory action of  $Q_1$ ,  $Q_2$  and  $T_1$  is not self-starting without some additional help when the input voltage is first applied. In fact, both transistors are initially biased off by resistors  $R_{b1}/R_{b2}$  and the secondaries  $T_{1a}/T_{1b}$  of transformer  $T_1$  which are connected between base and emitter of each transistor.

The start-up bias is provided by diac  $D_2$  together with the  $R_1/C_2$  network which generates a positive, going pulse in the base of  $Q_2$ . A silicon bilateral switch (SBS) will also work in place of a diac. After start-up, this circuit becomes inoperative by means of diode  $D_1$  which keeps the  $V_{BB}$  voltage at a value lower than the trigger voltage of the diac  $D_2$ . This point is important because it will prevent excessive base drive from being delivered to  $Q_2$ , hence, it will avoid the increased storage time associated with overdrive conditions.

The self-oscillation of the circuit is accomplished through the toroidal coupling of transformer  $T_1$  which gives

the needed regenerative action to Q<sub>1</sub> and Q<sub>2</sub>. The energy to drive the base of these transistors is obtained from the output power circuit. This is often referred to as a proportional base drive scheme.

Notice that the current is not a pure sine wave in the transistor. Current is not switched at zero but just after the collector current starts to fall. The base drive transformer (T<sub>1</sub>) is the main reason because as the collector current starts to fall, a -di/dt is sensed by the T<sub>1</sub> primary. This -di/dt causes the secondary to reverse its current. As the base current is reduced, the collector current is also reduced. This is the cause for turning off the transistor.

Figure 10 is an expansion of the power dissipated in the transistor. Heat is mainly created during switching.

### TYPICAL TRANSISTOR SELECTION CRITERIA

This section is being included as background material and represents most of the critical considerations that could be required in this type of ballast circuit. The new bipolar power transistor design discussed in this application note will help reduce the adverse effects of many of these parametric considerations.

The key power transistor parameters for this type of circuit are:

- V<sub>CE</sub> voltage
- Collector current and gain (h<sub>FE</sub>) variation
- Switching times (fall time and voltage storage time)
- Junction temperature

### SPECIFICATION ANALYSIS

#### V<sub>CE</sub> Voltage

When the converter is normally loaded with a fluorescent tube, the peak collector voltage that must be sustained by the transistor is equal to V<sub>CC</sub> (the rectified, filtered ac line), for a 220 volt input line:

$$V_{CC} = V_{rms} \sqrt{2}$$

$$V_{CC} = 220 \sqrt{2} = 311 \text{ V} \quad \text{Eq (5)}$$

Allowing for input line voltage variations of 15% and an additional 10% safety margin results in a minimum V<sub>(BR)CEO</sub> rating of 400 volts for Q<sub>1</sub>/Q<sub>2</sub> in this type of circuit.

The transistors should never be biased in the V<sub>(BR)CEO</sub> condition under normal operating conditions (the base-emitter network impedance is usually low) therefore, the V<sub>(BR)CER</sub> or V<sub>(BR)CES</sub> rating is the important parameter for this application and should be 700 volts.

(\*V<sub>(BR)CEO</sub>: collector emitter breakdown voltage, base open.)

#### Collector Current

The collector current rating for Q<sub>1</sub>/Q<sub>2</sub> needs to be analyzed from three aspects.

- Absolute peak value required for the steady-state condition

- Peak current for lamp starting
- Optimized die size to provide as much current gain as possible for the steady condition at the lowest possible die cost.

The peak collector current requirement at steady-state for this application can be computed from Eq (6), which represents the peak collector current value as a function of the output power.

$$I_{C(\text{peak})} = 2\sqrt{2} (P_{\text{tube}} / V_{\text{ac input}}) \quad \text{Eq (6)}$$

Note: Eq (6) is a first order approximation to help determine the current.

In this example, assuming a total output power condition of 116 watts (a common application today in Europe, two 58 watt tubes in parallel) and a line voltage of 220 volts nominal, the estimated steady-state I<sub>Cpeak</sub> required for this application, from Eq (7), is equal to 1.49 amperes.

$$\frac{116 \times 2 \times 1.414}{220} = 1.49 \quad \text{Eq (7)}$$

The variation in operating current from the milliamp range to amperes presents some unique problems in required dc gain levels. Also, since the load is inductive, the current increases exponentially. It becomes important to have a gain curve (beta or h<sub>FE</sub>) as a function of the collector current, h<sub>FE</sub> vs. I<sub>C</sub>, that is as flat as possible between the extreme values of I<sub>C</sub> for this application. In an application of a single 58 watt lamp without dimming, the range is 500 milliamps peak for lamp operation to 3.0 amperes peak for starting.

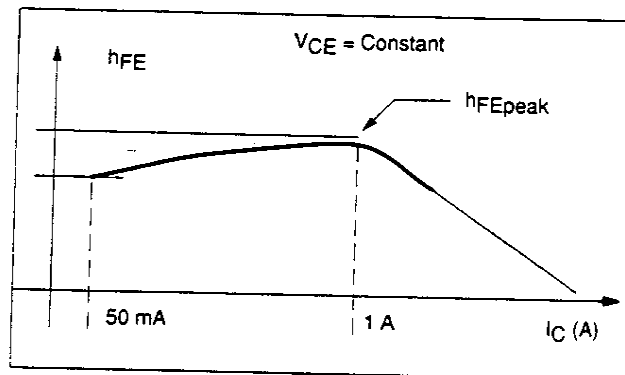

Figure 11. Typical Gain Curve h<sub>FE</sub> vs. I<sub>C</sub>

#### DC Current Gain (h<sub>FE</sub>)

A typical power transistor gain curve looks like the one given in Figure 11 where the curve starts at 50 milliamps and peaks at one ampere. Beyond the one ampere area the gain slope quickly decreases.

The required break point of the gain curve is a critical parameter in this application because its required value is influenced by two areas in the circuit that affect the overall performance.

- Saturation voltage V<sub>CE(sat)</sub>
- Collector peak current

Theoretically,  $h_{FE}$  should be as high as possible to give the lowest possible saturation voltage at the highest possible operating current with the minimum amount of base drive. This reduces the on-losses in both the output and drive circuits. However, other tradeoffs such as switching speed and voltage capability will limit the maximum value of  $h_{FE}$ .

Therefore, both the actual value of the gain and its variation above and below the average value from one production lot to the next are critical parameters. However, since it is practically impossible to keep the gain spread within a  $\pm 10\%$  range for a given  $I_C$ , the design of an electronic ballast must include the necessary feedback to get a stable operating point for the transistors. This is easily achieved by putting a resistor  $R_E$  in series with each of the transistor's emitters.

The value of  $R_E$  results from a compromise between the allowable losses in the resistors (Joule effect) and the need to have a feedback voltage  $V_{EE}$  higher than the transistor  $V_{BE(on)}$ .

When the  $V_{CE}$  voltage is low (12 volt, battery-fed converters) the problem becomes worse due to the lower available voltage swing to feed the output circuit. Usually, for the ballast fed from the 220 volt mains, the value of  $R_E$  is computed by using Eq (8).

$$R_E = 2 V_{BE(on)} / I_C(\text{peak}) \quad \text{Eq (8)}$$

For a typical 55 watt tube,  $R_E$  will be equal to 2.2  $\Omega$ , 0.5 watts.

### Switching Times

These are the key factors in this kind of circuit. In fact, concerning the losses during the collector current switch off, we've seen in Eq (2), that those losses were proportional to the  $t_C$ , this parameter being linked to the transistor  $t_{fi}$  (see parameter definitions in the Appendix).

Therefore, the  $V_{CE}/I_C$  conditions being a function of the application, one must minimize the  $t_{fi}$  value through the base driver by removing the carriers stored in the junction and/or by selecting the type of component with the best performance for that parameter. However, the most efficient base drive circuits are expensive and cannot be used in the low cost market. The negative current is limited, moreover, by resistors  $R_{b1}/R_{b2}$ . One solution is to use a BAKER clamp as described in Figure 12.

The second important switching time parameter is the voltage storage time  $t_{sj}$  (see definition in the Appendix). It will directly influence the converter operating frequency and its timing versus the resonant circuit  $L/C$ . Also, a large differential between the  $t_{sj}$  of  $Q_1$  and  $Q_2$  yields a probability of output stage destruction because of the asymmetry that will exist in the feeding of the  $L/C$  network. This asymmetry can cause a dc current to flow in the inductor which causes the core to saturate.

The oscillation frequency of existing electronic light ballasts is typically around 40 kHz, or a 25  $\mu s$  period. One can see that the  $t_{sj}$  cannot exceed 20% of this value. Beyond 20% the operating point moves too far from the reso-

nant frequency (see the Appendix) yielding high losses in the power transistors which increases the junction temperature, downgrading the total light ballast efficiency.

Several electronic solutions are possible using complex drive circuits which will have a significant effect on the total cost. In order to avoid this cost many design engineers think that having the semiconductor manufacturer select transistors and match them for the  $t_{sj}$  parameter is a possible solution. However, it should be noted that inductive dynamic switching parameters are not 100% measured in semiconductor production testing. Correlation between test circuits and application circuits, lot-to-lot variations, test time and yields, usually make this approach extremely expensive and unpredictable. The unpredictability may be the worst problem because it can result in major delivery problems and cause the end user unforecasted expenses that can completely dwarf the original cost of designing the proper circuitry.

### Junction Temperature

Under any condition the junction temperature should not be higher than the maximum specified for the transistors. In order to minimize the manufacturing costs, transistors  $Q_1$  and  $Q_2$  are mounted without heatsinks. To perform the calculation of the junction to ambient thermal ( $R_{\theta JA}$ ) resistance is required. For a TO-220 package  $R_{\theta JA}$  is 62.5°C/Watt.

With the maximum ambient temperature inside the box for an electronic ballast being limited to 70°C, we can compute the maximum allowable losses in the transistor, (with  $T_{Jmax} = < 150^\circ C$ ).

$$P_{max} = (T_{Jmax} - T_{amb}) / R_{\theta JA} \quad \text{Eq (9)}$$

$$P_{max} = (150 - 70) / 62.5 = 1.28 \text{ W}$$

This power level includes the ON losses seen in Eq (3), those due to switching as seen in Eq (2) as well as those in the base.

It becomes obvious that a low  $t_{fi}$  together with a high gain will minimize the total losses in the transistor.

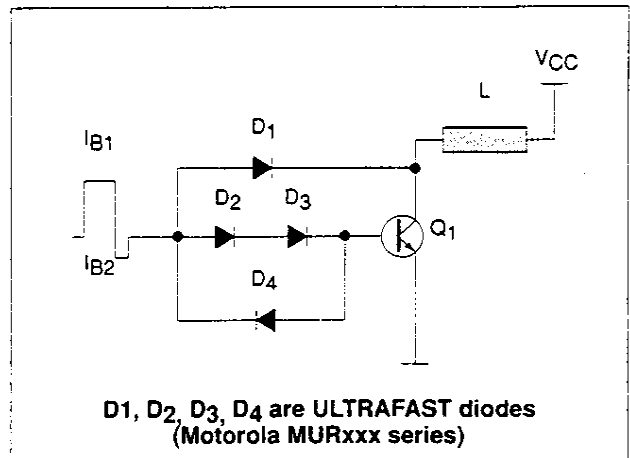

Figure 12. Typical Baker Clamp Circuit

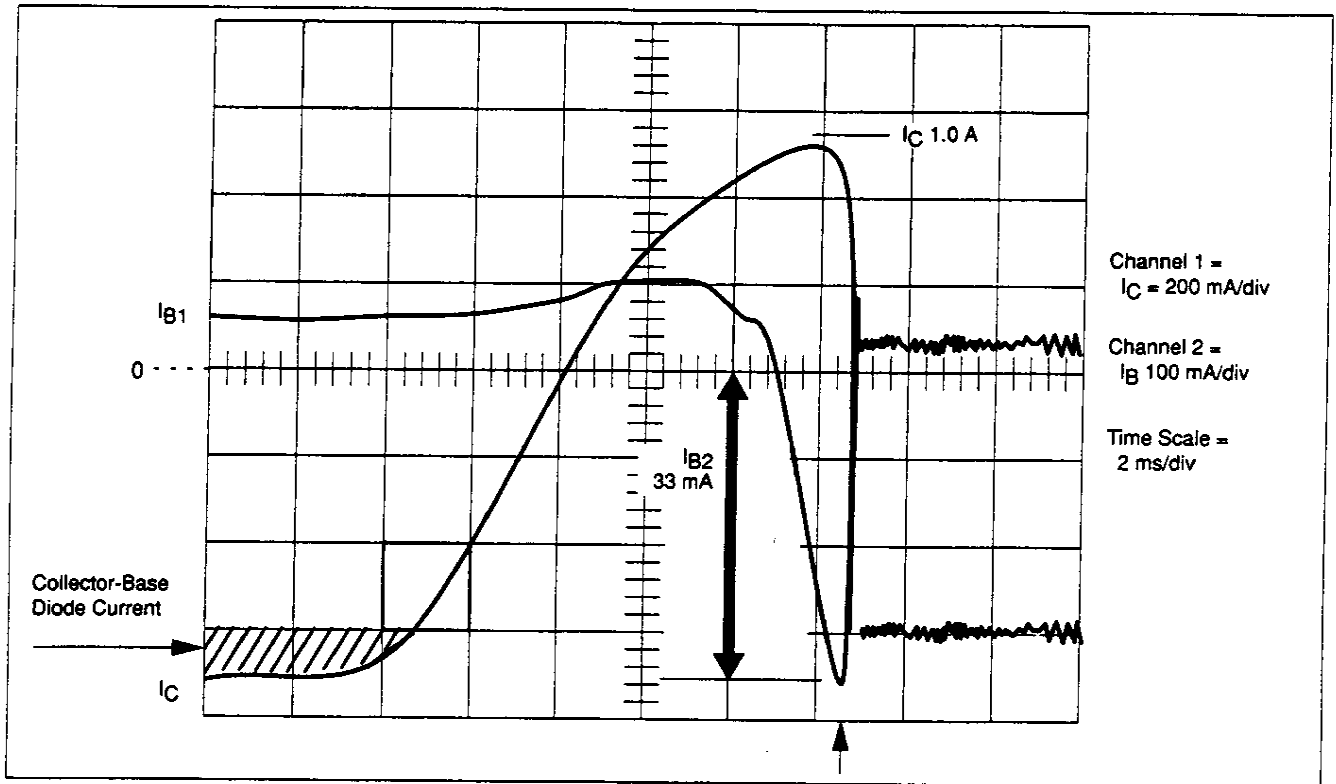

Figure 13. Collector Current and  $I_{B1}/I_{B2}$

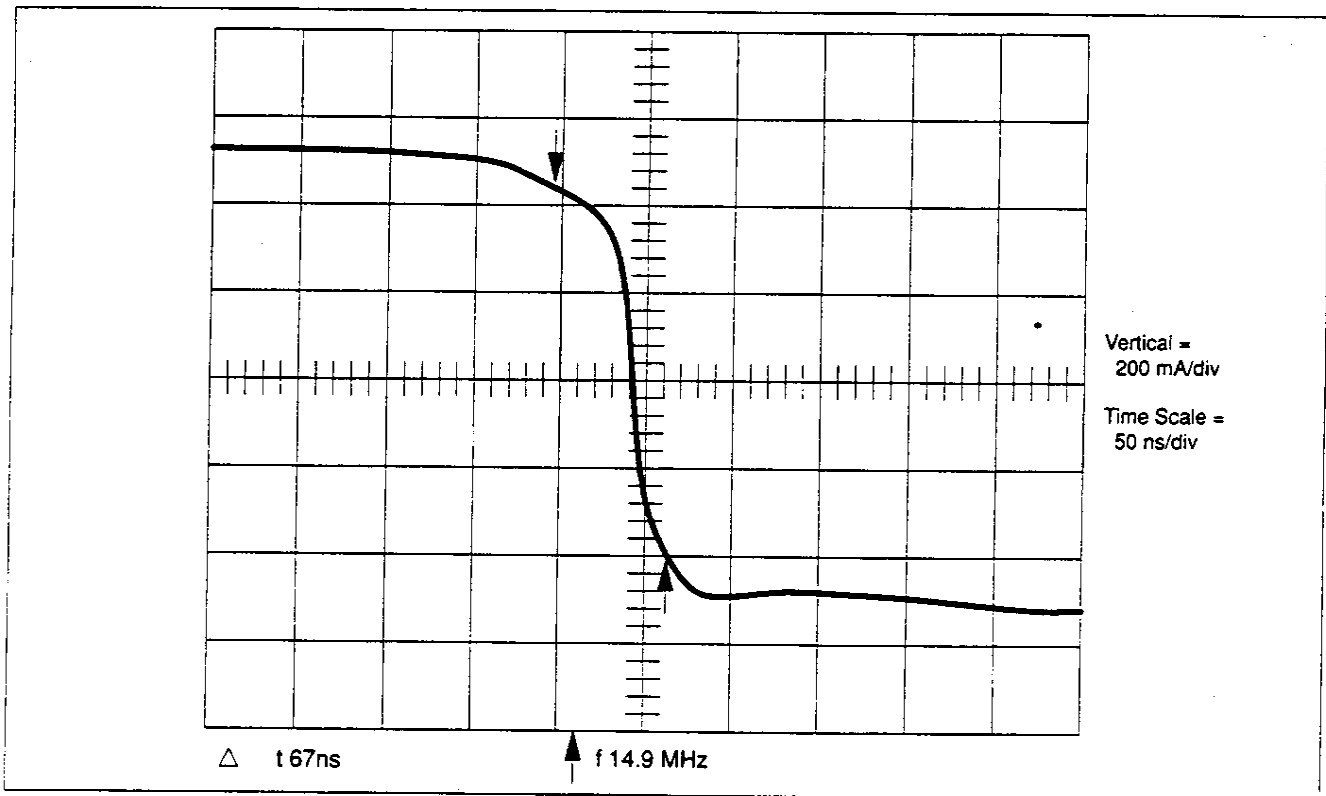

Figure 14. Collector Current Turn-Off Time ( $t_{fi}$ )

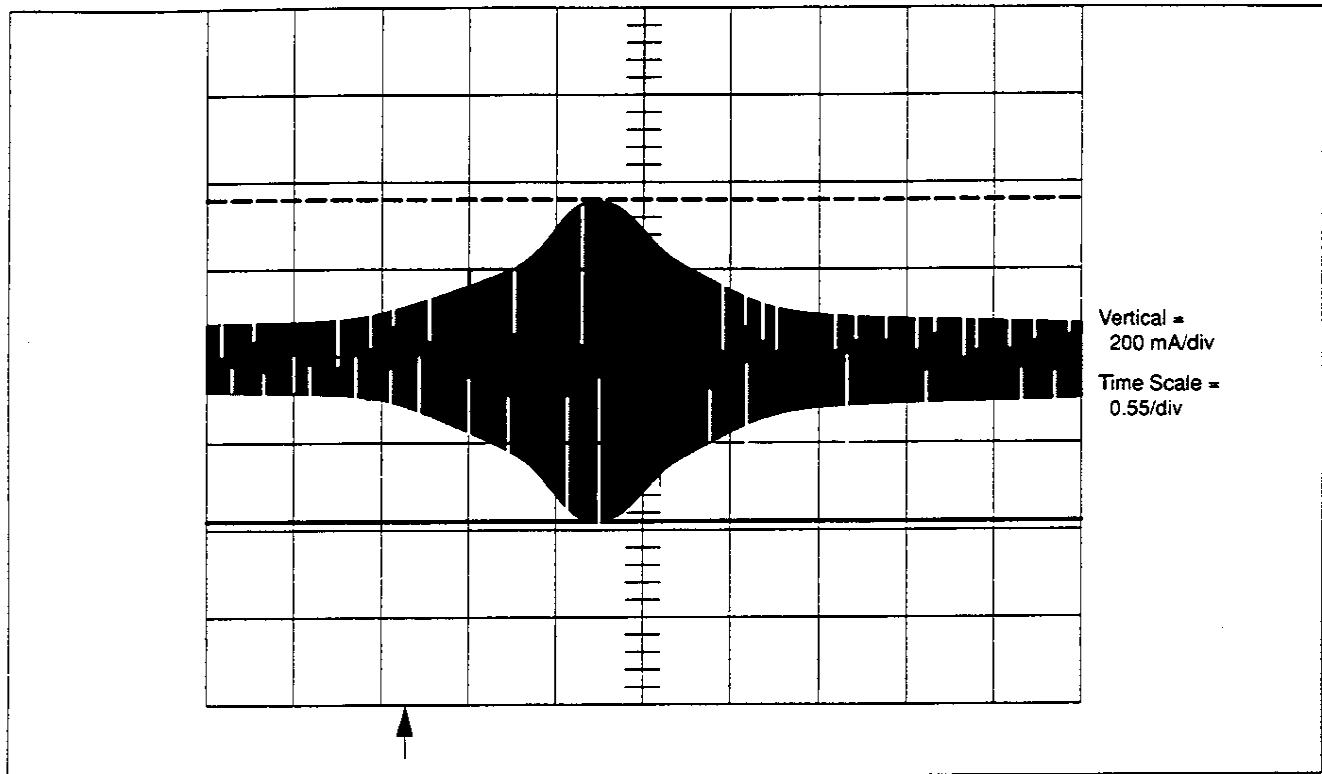

Figure 15. LC Series Circuit Current

## THE MOTOROLA APPROACH

Keeping in mind the stresses applied to the semiconductors in an electronic ballast, Motorola has developed state-of-the-art bipolar power transistors to meet the needs of this application, the BUL44 and BUL45. These devices are specifically designed for lamp ballast applications: the BUL44 up to 50 watt circuits and the BUL45 up to 120 watts.

The following analysis discusses the BUL45 specifications in reference to the voltage fed resonant circuit of Figure 7.

### SWITCHING TIME

The inductive storage time ( $t_{si}$ ) and inductive fall time ( $t_{fi}$ ) by design are very low values making them compatible with the simple base drives in today's electronic ballasts.

However, even more important than the absolute value of  $t_{si}$ , is the guaranteed distribution of  $\pm 0.6 \mu s$ , yielding a stable and safe converter operating without any special screening and/or matching of the power transistors. Also, the  $t_{fi}$  is specified at a maximum of 200 ns at  $T_J = 100^\circ C$ , therefore, the switching losses remain low even at elevated junction temperature.

This switching time optimization allows the design of electronic ballasts with chopper frequencies up to 50 kHz

without significant change in parametric distribution from one lot of components to another.

### BREAKDOWN VOLTAGE

With a  $V_{(BR)CEV}$  minimum of 700 volts, these lamp ballast devices offer an adequate voltage safety margin in most applications, including usage in the U.K. with a line voltage of 240 volts.

### DC CURRENT GAIN

The minimum guaranteed is 16 at  $I_C = 1 A$ ,  $V_{CE} = 5 V$  and  $T_C = + 25^\circ C$  with a distribution of  $\pm 30\%$  from one lot of components to another.

This high-gain level allows for simple base drive design, keeping the  $V_{CE(sat)}$  low, hence, keeping low ON state losses.

From these general specifications we can evaluate the BUL45 typical behavior for an output power of 2 x 55 watts or 110 watts at 40 kHz.

$$P_{switch} = V_{CE(peak)} \times I_{C(peak)} \times t_{fi} \times f / 2$$

$$P_{switch} = (310 \times 1.8 \times 100 \times 10^{-9} \times 40 \times 10^3) / 2$$

$$P_{switch} = 0.11 W$$

Note: assumes a  $V_{CE} dv/dt$  of 300 V/ $\mu s$ , with a collector load of 2 mH.

$$P_{sat} = V_{CE(sat)} \times I_{C(peak)} \times t_{on} \times f / 2$$

$$P_{sat} = (0.35 \times 1.8 \times 12.5 \times 10^{-6} \times 40 \times 10^3) / 2$$

$$P_{sat} = 0.15$$

$$P_{base} = V_{BE(sat)} \times I_B \times t_{on} \times f$$

$$P_{base} = 1.5 \times 0.25 \times 12.5 \times 10^{-6} \times 40 \times 10^3$$

$$P_{base} = 0.18 \text{ W}$$

$$P_{total} = P_{switch} + P_{sat} + P_{base}$$

$$P_{total} = 0.11 + 0.15 + 0.18$$

$$P_{total} = 0.44 \text{ W}$$

$$T_J = (R_{thja} \times P_{total}) + T_{amb}$$

$$T_J = (62.5 \times 0.44) + 70$$

$$T_J = 97.5^\circ\text{C}$$

### EVALUATION CIRCUIT

In order to verify the performance that was discussed in the previous paragraphs, Motorola designed an evaluation circuit using the voltage fed resonant topology, as described in Figure 7. The actual circuit is shown in Figure 16.

Figure 16 is a series resonant proportional base drive circuit. The base drive is obtained from a toroidal transformer with a single turn for the primary and 10 turns for each secondary T<sub>1A</sub> and T<sub>1B</sub>. The toroid is ferrite and is similar to 3C6A material from Ferroxcube or F Material

from Magnetics. The physical dimensions are 0.375 inches OD, 0.1875 inches ID and 0.125 inches thick.

The main inductor, L, is 2 mH wound on an RM8 core. Any number of power ferrites will work like the 3C6A and F mentioned above. The wire used for the turns should be Litz type 1, which is copper magnet wire twisted together greater than 20 twists per foot. When large solid single strand magnet wire is used, the R<sub>ac</sub>/R<sub>dc</sub> ratio is large and heating occurs in the wire especially if many layers are used.

To feed a 55 watt tube, the collector peak current is equal to :

$$I_{CP} = 2\sqrt{2} \times (P/V_{ac})$$

$$I_{CP} = 2\sqrt{2} \times (55/220) = 0.707 \text{ A}$$

Since the BUL45 has a collector current rating of 2 amperes (continuous), the operating current for this application should not present any particular problem.

Assuming an oscillation frequency of 35 kHz, together with a dv/dt of 300 V/μs and a forced gain of 15, the losses in Q<sub>1</sub>/Q<sub>2</sub> are as follows:

$$P_{switch} = (0.7 \times 31 \times 150 \times 10^{-9} \times 35 \times 10^{-3}) / 2 = 0.570 \text{ W}$$

$$P_{sat} = (0.7 \times 1.2 \times 12.5 \times 10^{-6} \times 35 \times 10^{-3}) / 2 = 0.184 \text{ W}$$

$$P_{base} = (0.05 \times 1.8 \times 12.5 \times 10^{-6} \times 35 \times 10^{-3}) = 0.055 \text{ W}$$

$$P_{total} = P_{switch} + P_{sat} + P_{base} = 0.570 + 0.184 + 0.055$$

$$= 0.809 \text{ W}$$

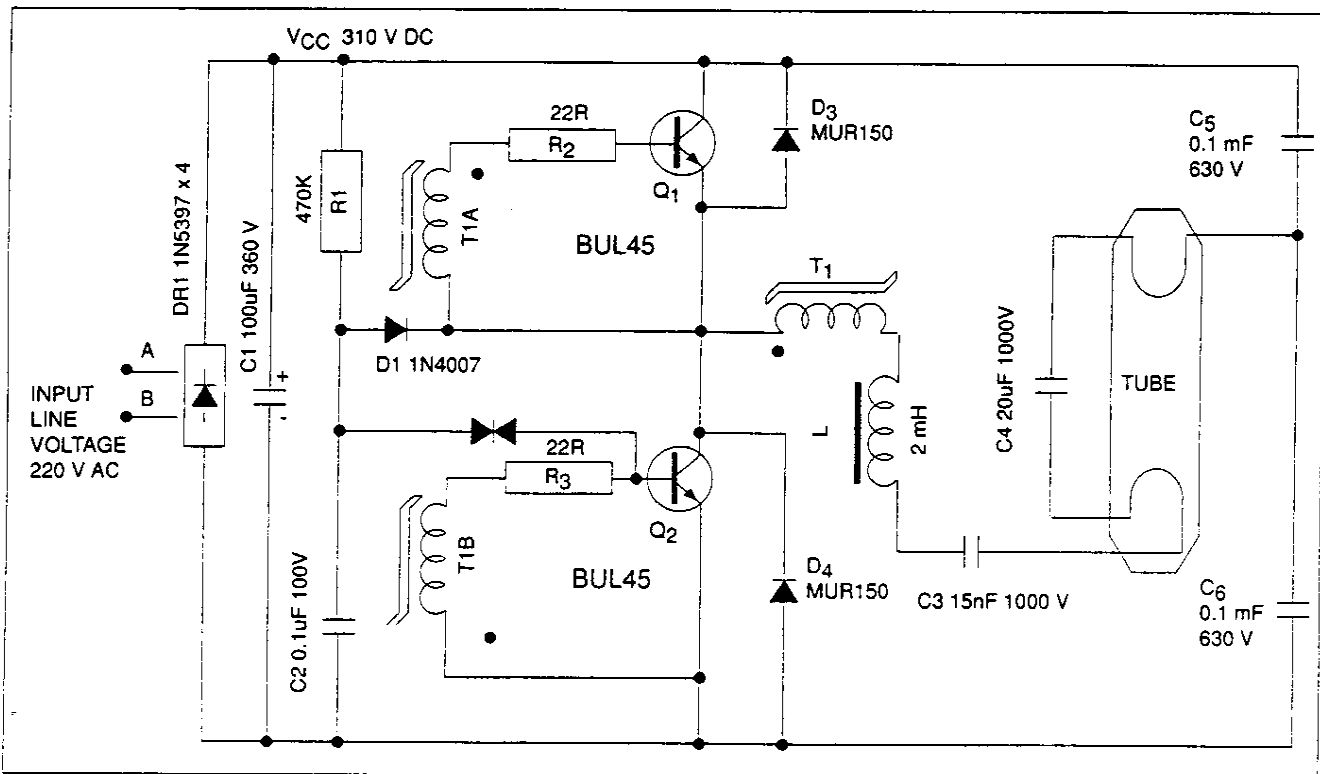

Figure 16. Evaluation Circuit

Yielding, a steady-state junction temperature of (assuming  $T_{amb} = 70^{\circ}\text{C}$ ):

$$T_J = (R_{thja} \times P_{tot}) + T_{amb}$$

$$T_J = (62.5 \times 0.924) + 70 = 127.25^{\circ}\text{C}$$

Which is well below the maximum allowable for  $T_J$

and should result in good long-term reliability for the transistors. Figure 17 (scale 1/1) shows the P.C. board design and Figure 18 shows the component layout on this evaluation board.

Note: Since this design doesn't include the line input filter, it can't be used "as is" in a practical industrial circuit

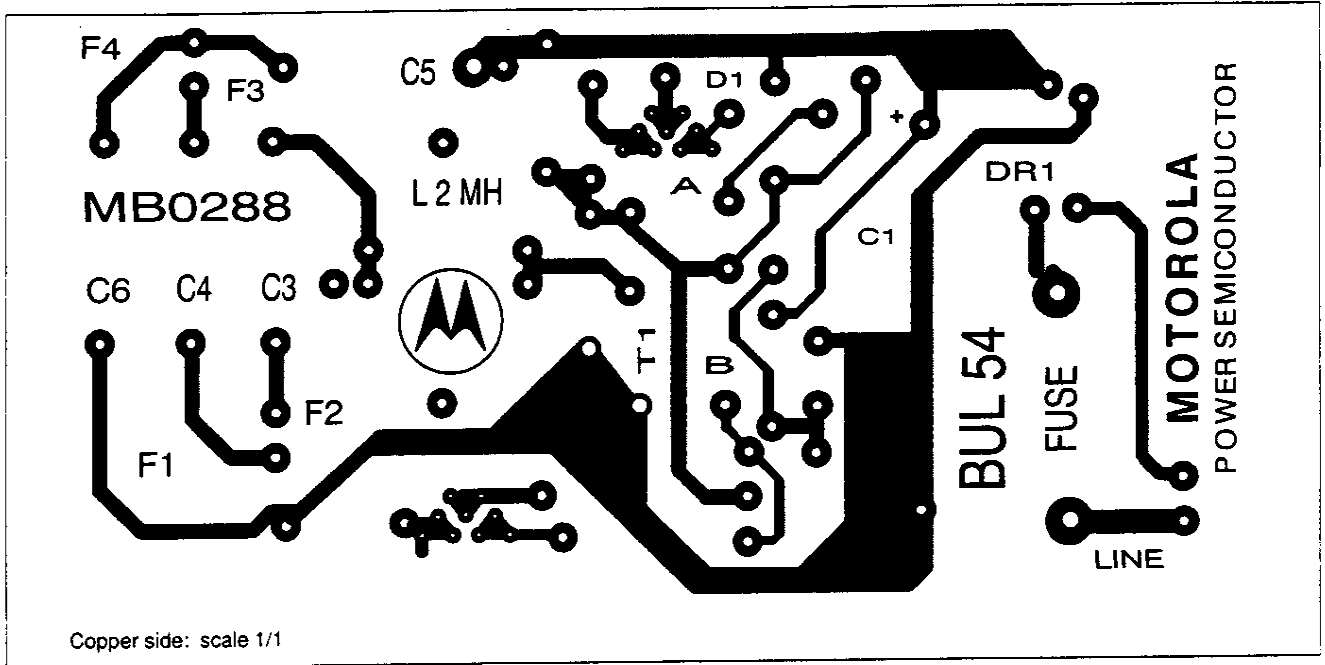

Figure 17. P.C. Board Layout

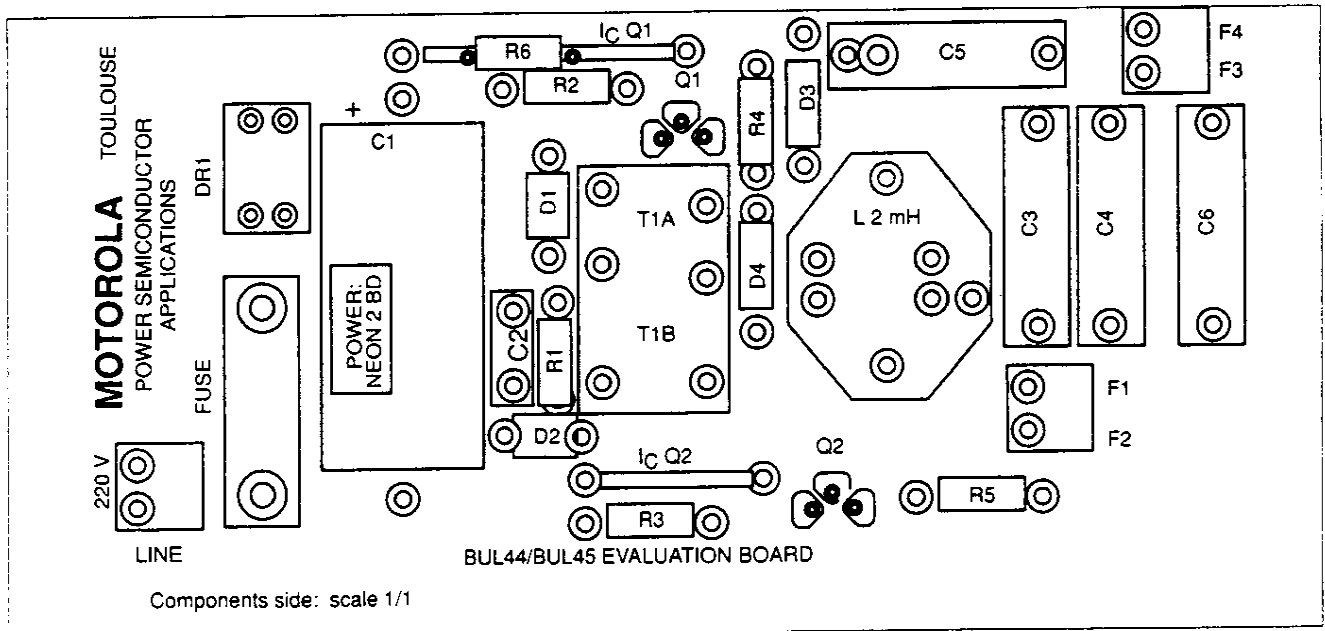

Figure 18. Component Layout

## CONCLUSIONS

This particular study has discussed the main advantages as well as the major drawbacks of fluorescent tube electronic control.

The importance of controlling the power transistor's dynamic parameters to guarantee stable operation and superior performance in a voltage fed series resonant converter circuit was discussed in detail.

The evaluation circuit helped to demonstrate how the application specific design of the BUL45 power transistor could provide excellent performance without any special screening or matching. Screening or matching power transistor dynamic parameters can add significant cost to the base price of the device.

## APPENDIX

### I Series Resonant Basic Characteristics

Outside resonance, the current is given by:

$$I = V_{in} / \sqrt{R^2 + (L\omega - 1/C\omega)^2} \quad \text{Eq (10)}$$

When the circuit is tuned, i.e. when  $f = f_0$ , then:

- the impedance is equal to the pure ohmic circuit resistance

$$Z = R \quad \text{Eq (11)}$$

- the voltage across the capacitor is at a maximum value

$$V_C = V_{in} \times (1 + Q^2) \quad \text{Eq (12)}$$

- the current in the circuit is at a maximum value

$$I = V_{in}/R \quad \text{Eq (13)}$$

The quality factor Q will set the circuit selectivity

$$Q = L\omega/R \quad \text{Eq (14)}$$

The Q factor can be derived from the circuit component values

$$Q = (1/R) (\sqrt{L/C}) \quad \text{Eq (15)}$$

### II Switching Parameter Definitions

The measurements are performed in accordance with industry recognized standard test conditions which are typically world-wide recognized standards.

**I<sub>B1</sub>**: for the device under test is the base-emitter forward biasing current.

**I<sub>B2</sub>**: for the device under test is the base-emitter reverse bias current. This current is the vehicle by which the stored charge in the base of the transistor is removed rapidly. The reverse bias can also be created by means of a voltage source connected between base-emitter known as  $V_{BEoff}$ , with the current being limited only by the circuit impedance.

### A-Pure resistive loads

**t<sub>d</sub>**: delay time

10% I<sub>B1</sub> to 10% I<sub>C</sub>, positive slopes

**t<sub>r</sub>**: collector current rise time

10% I<sub>C</sub> to 90% I<sub>C</sub>, positive slopes

**t<sub>on</sub>**: total collector current turn-on time

t<sub>on</sub> = t<sub>d</sub> + t<sub>r</sub>

**t<sub>s</sub>**: collector current storage time

90% I<sub>B1</sub> to 90% I<sub>C</sub>, negative slopes

**t<sub>f</sub>**: collector current fall time

90% I<sub>C</sub> to 10% I<sub>C</sub>, negative slopes

**t<sub>off</sub>**: total collector current turn-off time

t<sub>off</sub> = t<sub>s</sub> + t<sub>f</sub>

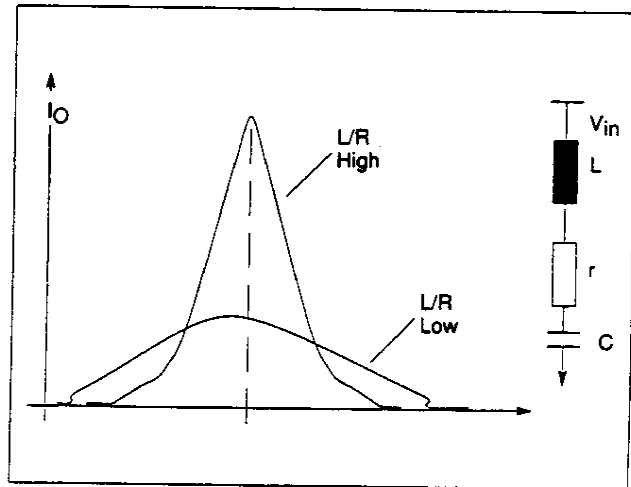

Figure A1. Series Resonant Response Curve

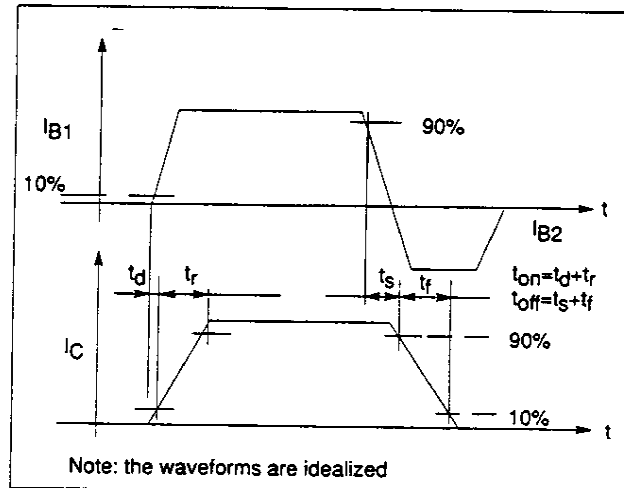
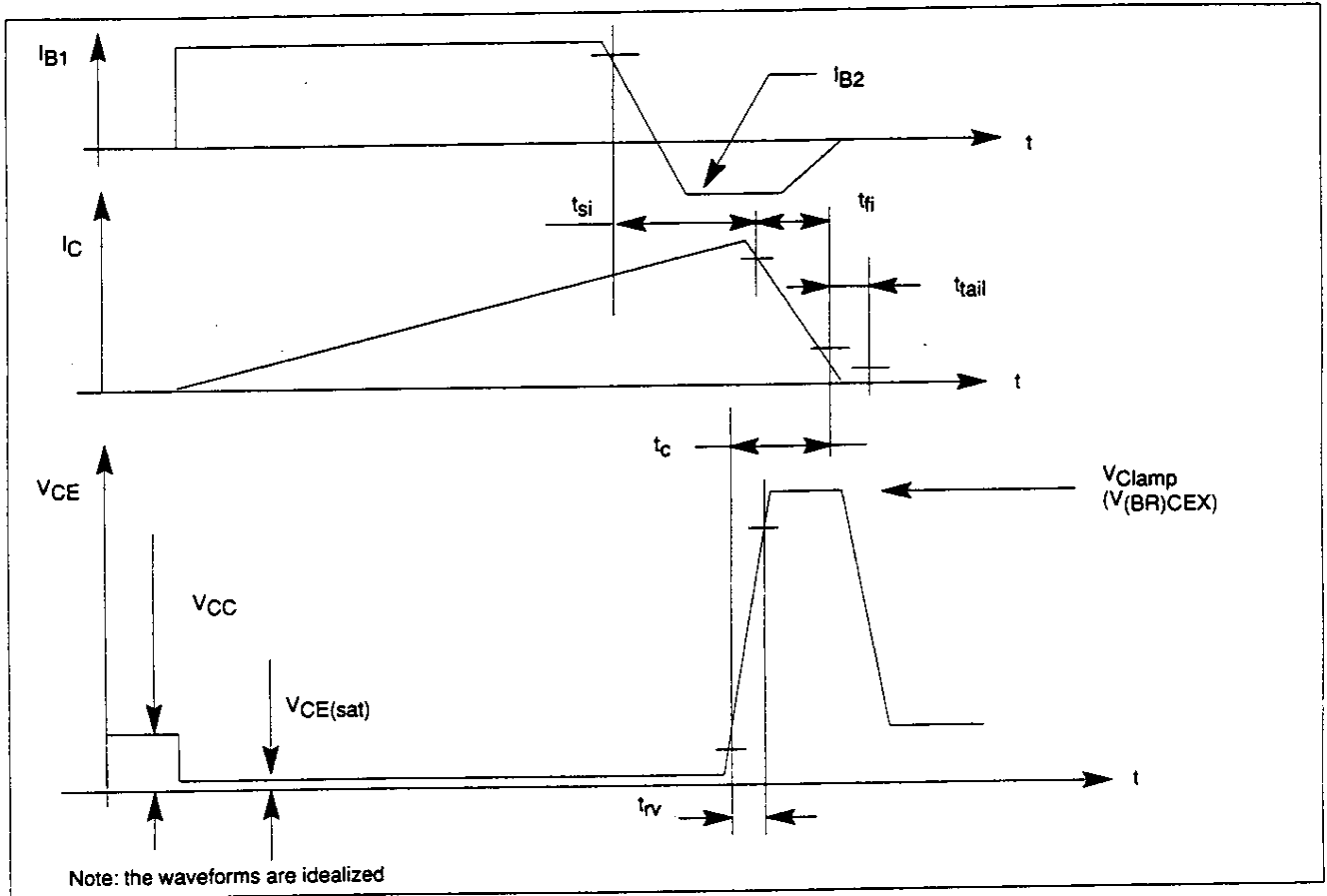

Figure A2. Switching Time Parameter Definitions (Resistive Load)

**B-Inductive load**

$t_{si}$ : collector current storage time  
 90%  $I_{B1}$  to 90%  $I_C$ , negative slopes  
 $t_{fj}$ : collector current fall time  
 90%  $I_C$  to 10%  $I_C$ , negative slopes  
 $t_c$ :  $I_C$  and  $V_{CE}$  crossover time

10%  $V_{CE}$ , positive slope, to 10%  $I_C$ , negative slope  
 $t_{rv}$ : collector voltage rise time  
 10%  $V_{CE}$  to 90%  $V_{CE}$ , positive slopes  
 $t_{tail}$ : collector current trailing time  
 10%  $I_C$  to 2%  $I_C$ , negative slope  
 $V_{Clamp}$  ( $V_{(BR)CEX}$ ): maximum allowed collector voltage

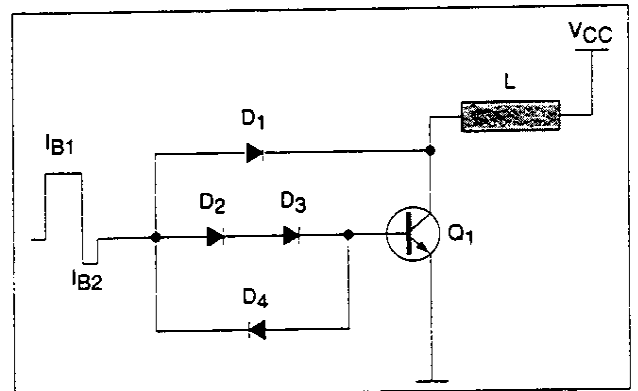

**Figure A3. Switching Time Parameter Definitions (Inductive Load)**

**III Baker Clamp Drive Circuit**

When transistor  $Q_1$  in Figure A4 is driven hard toward saturation, diode  $D_1$  diverts some of the current from the base drive circuit into the collector path, resulting in a limited saturation condition for  $Q_1$  (i.e.,  $Q_1$  is just barely in the saturated condition and is not overdriven by  $I_{B1}$ ). Therefore, less carriers are stored in the base-emitter junction, which results in minimum storage time ( $t_{si}$ ).

At turn off, diode  $D_4$  is used to route the stored charge from the transistor directly into the negative bias supply.



**Figure A4. Baker Clamp Typical Circuit**

#### IV 120 VAC Operation

A 220 V ballast can be operated from 120 VAC by using a voltage doubler (see Figure 5A). This produces a rectified DC bus of approximately 310 V for either 120 or

220 V applications. The center tap can be formed by using two coupling capacitors (C3 in Figure 7) or by splitting the filter capacitor as in Figure 16.

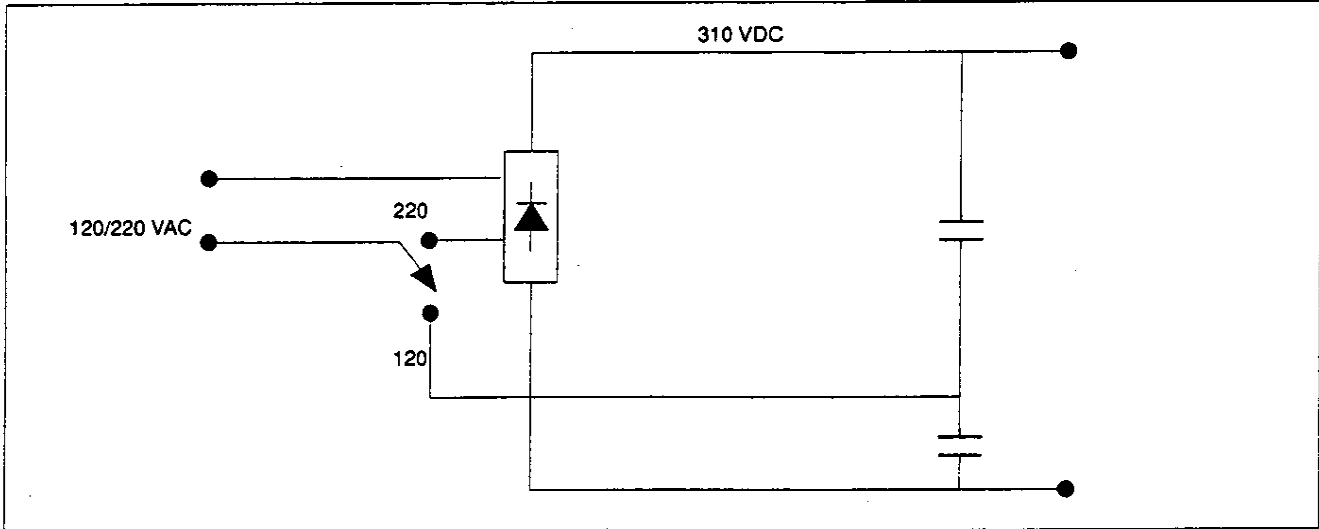



Figure 5A. Voltage Doubler

Motorola reserves the right to make changes without further notice to any products herein. Motorola makes no warranty, representation or guarantee regarding the suitability of its products for any particular purpose, nor does Motorola assume any liability arising out of the application or use of any product or circuit, and specifically disclaims any and all liability, including without limitation consequential or incidental damages. "Typical" parameters can and do vary in different applications. All operating parameters, including "Typicals" must be validated for each customer application by customer's technical experts. Motorola does not convey any license under its patent rights nor the rights of others. Motorola products are not designed, intended, or authorized for use as components in systems intended for surgical implant into the body, or other applications intended to support or sustain life, or for any other application in which the failure of the Motorola product could create a situation where personal injury or death may occur. Should Buyer purchase or use Motorola products for any such unintended or unauthorized application, Buyer shall indemnify and hold Motorola and its officers, employees, subsidiaries, affiliates, and distributors harmless against all claims, costs, damages, and expenses, and reasonable attorney fees arising out of, directly or indirectly, any claim of personal injury or death associated with such unintended or unauthorized use, even if such claim alleges that Motorola was negligent regarding the design or manufacture of the part. Motorola and  are registered trademarks of Motorola, Inc. Motorola, Inc. is an Equal Opportunity/Affirmative Action Employer.

#### Literature Distribution Centers:

USA: Motorola Literature Distribution; P.O. Box 20912; Phoenix, Arizona 85036.

EUROPE: Motorola Ltd.; European Literature Centre; 88 Tanners Drive, Blakelands, Milton Keynes, MK14 5BP, England.

JAPAN: Nippon Motorola Ltd.; 4-32-1, Nishi-Gotanda, Shinagawa-ku, Tokyo 141, Japan.

ASIA PACIFIC: Motorola Semiconductors H.K. Ltd.; Silicon Harbour Center, No. 2 Dai King Street, Tai Po Industrial Estate, Tai Po, N.T., Hong Kong.



**MOTOROLA**

24187 PRINTED IN USA (1994) MPS/POD BIP PWR YAAAAA

AN1049/D

