



1.5 A, Adjustable Output, Negative Voltage Regulator

The LM337 is an adjustable 3-terminal negative voltage regulator capable of supplying in excess of 1.5 A over an output voltage range of -1.2 V to -37 V. This voltage regulator is exceptionally easy to use and requires only two external resistors to set the output voltage. Further, it employs internal current limiting, thermal shutdown and safe area compensation, making it essentially blow-out proof.

The LM337 serves a wide variety of applications including local, on card regulation. This device can also be used to make a programmable output regulator, or by connecting a fixed resistor between the adjustment and output, the LM337 can be used as a precision current regulator.

- Output Current in Excess of 1.5 A
- Output Adjustable between -1.2 V and -37 V
- Internal Thermal Overload Protection
- Internal Short Circuit Current Limiting Constant with Temperature
- Output Transistor Safe-Area Compensation
- Floating Operation for High Voltage Applications
- Eliminates Stocking many Fixed Voltages
- Available in Surface Mount D²PAK and Standard 3-Lead Transistor Package

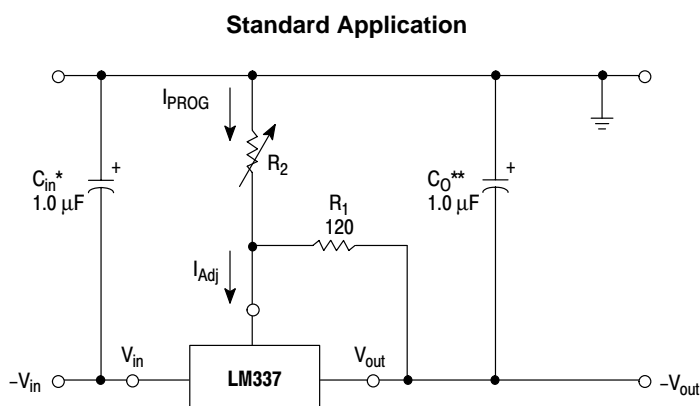

*C_{in} is required if regulator is located more than 4 inches from power supply filter. A 1.0 μF solid tantalum or 10 μF aluminum electrolytic is recommended.

**C_O is necessary for stability. A 1.0 μF solid tantalum or 10 μF aluminum electrolytic is recommended.

$$V_{out} = -1.25 V \left(1 + \frac{R_2}{R_1} \right)$$

LM337

THREE-TERMINAL ADJUSTABLE NEGATIVE VOLTAGE REGULATOR

SEMICONDUCTOR TECHNICAL DATA

T SUFFIX
PLASTIC PACKAGE
CASE 221A

Heatsink surface connected to Pin 2.

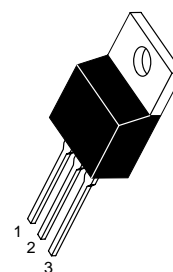

Pin 1. Adjust
2. V_{in}
3. V_{out}

D2T SUFFIX
PLASTIC PACKAGE
CASE 936
(D²PAK)

Heatsink surface (shown as terminal 4 in case outline drawing) is connected to Pin 2.

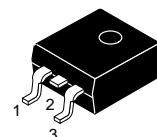

ORDERING INFORMATION

Device	Operating Temperature Range	Package
LM337BD2T	T _J = -40° to +125°C	Surface Mount
LM337BT		Insertion Mount
LM337D2T	T _J = 0° to +125°C	Surface Mount
LM337T		Insertion Mount

LM337

MAXIMUM RATINGS

Rating	Symbol	Value	Unit
Input–Output Voltage Differential	V_I-V_O	40	Vdc
Power Dissipation Case 221A $T_A = +25^\circ\text{C}$ Thermal Resistance, Junction–to–Ambient Thermal Resistance, Junction–to–Case Case 936 (D ² PAK) $T_A = +25^\circ\text{C}$ Thermal Resistance, Junction–to–Ambient Thermal Resistance, Junction–to–Case	P_D θ_{JA} θ_{JC} P_D θ_{JA} θ_{JC}	Internally Limited 65 5.0 Internally Limited 70 5.0	W $^\circ\text{C/W}$ $^\circ\text{C/W}$ W $^\circ\text{C/W}$ $^\circ\text{C/W}$
Operating Junction Temperature Range	T_J	–40 to +125	$^\circ\text{C}$
Storage Temperature Range	T_{stg}	–65 to +150	$^\circ\text{C}$

ELECTRICAL CHARACTERISTICS ($|V_I-V_O| = 5.0\text{ V}$; $I_O = 0.5\text{ A}$ for T package; $T_J = T_{\text{low}}$ to T_{high} [Note 1]; I_{max} and P_{max} [Note 2].)

Characteristics	Figure	Symbol	Min	Typ	Max	Unit
Line Regulation (Note 3), $T_A = +25^\circ\text{C}$, $3.0\text{ V} \leq V_I-V_O \leq 40\text{ V}$	1	Reg_{line}	–	0.01	0.04	%/V
Load Regulation (Note 3), $T_A = +25^\circ\text{C}$, $10\text{ mA} \leq I_O \leq I_{\text{max}}$ $ V_O \leq 5.0\text{ V}$ $ V_O \geq 5.0\text{ V}$	2	Reg_{load}	– –	15 0.3	50 1.0	mV % V_O
Thermal Regulation, $T_A = +25^\circ\text{C}$ (Note 6), 10 ms Pulse		$\text{Reg}_{\text{therm}}$	–	0.003	0.04	% V_O/W
Adjustment Pin Current	3	I_{Adj}	–	65	100	μA
Adjustment Pin Current Change, $2.5\text{ V} \leq V_I-V_O \leq 40\text{ V}$, $10\text{ mA} \leq I_L \leq I_{\text{max}}$, $P_D \leq P_{\text{max}}$, $T_A = +25^\circ\text{C}$	1, 2	ΔI_{Adj}	–	2.0	5.0	μA
Reference Voltage, $T_A = +25^\circ\text{C}$, $3.0\text{ V} \leq V_I-V_O \leq 40\text{ V}$, $10\text{ mA} \leq I_O \leq I_{\text{max}}$, $P_D \leq P_{\text{max}}$, $T_J = T_{\text{low}}$ to T_{high}	3	V_{ref}	–1.213 –1.20	–1.250 –1.25	–1.287 –1.30	V
Line Regulation (Note 3), $3.0\text{ V} \leq V_I-V_O \leq 40\text{ V}$	1	Reg_{line}	–	0.02	0.07	%/V
Load Regulation (Note 3), $10\text{ mA} \leq I_O \leq I_{\text{max}}$ $ V_O \leq 5.0\text{ V}$ $ V_O \geq 5.0\text{ V}$	2	Reg_{load}	– –	20 0.3	70 1.5	mV % V_O
Temperature Stability ($T_{\text{low}} \leq T_J \leq T_{\text{high}}$)	3	T_S	–	0.6	–	% V_O
Minimum Load Current to Maintain Regulation ($ V_I-V_O \leq 10\text{ V}$) ($ V_I-V_O \leq 40\text{ V}$)	3	I_{Lmin}	– –	1.5 2.5	6.0 10	mA
Maximum Output Current $ V_I-V_O \leq 15\text{ V}$, $P_D \leq P_{\text{max}}$, T Package $ V_I-V_O \leq 40\text{ V}$, $P_D \leq P_{\text{max}}$, $T_J = +25^\circ\text{C}$, T Package	3	I_{max}	– –	1.5 0.15	2.2 0.4	A
RMS Noise, % of V_O , $T_A = +25^\circ\text{C}$, $10\text{ Hz} \leq f \leq 10\text{ kHz}$		N	–	0.003	–	% V_O
Ripple Rejection, $V_O = -10\text{ V}$, $f = 120\text{ Hz}$ (Note 4) Without C_{Adj} $C_{\text{Adj}} = 10\text{ }\mu\text{F}$	4	RR	– 66	60 77	– –	dB
Long–Term Stability, $T_J = T_{\text{high}}$ (Note 5), $T_A = +25^\circ\text{C}$ for Endpoint Measurements	3	S	–	0.3	1.0	%/1.0 k Hrs.
Thermal Resistance Junction–to–Case, T Package		$R_{\theta\text{JC}}$	–	4.0	–	$^\circ\text{C/W}$

NOTES: 1. T_{low} to $T_{\text{high}} = 0^\circ$ to $+125^\circ\text{C}$, for LM337T, D2T. T_{low} to $T_{\text{high}} = -40^\circ$ to $+125^\circ\text{C}$, for LM337BT, BD2T.

2. $I_{\text{max}} = 1.5\text{ A}$, $P_{\text{max}} = 20\text{ W}$

3. Load and line regulation are specified at constant junction temperature. Change in V_O because of heating effects is covered under the Thermal Regulation specification. Pulse testing with a low duty cycle is used.

4. C_{Adj} , when used, is connected between the adjustment pin and ground.

5. Since Long Term Stability cannot be measured on each device before shipment, this specification is an engineering estimate of average stability from lot to lot.

6. Power dissipation within an IC voltage regulator produces a temperature gradient on the die, affecting individual IC components on the die. These effects can be minimized by proper integrated circuit design and layout techniques. Thermal Regulation is the effect of these temperature gradients on the output voltage and is expressed in percentage of output change per watt of power change in a specified time.

LM337

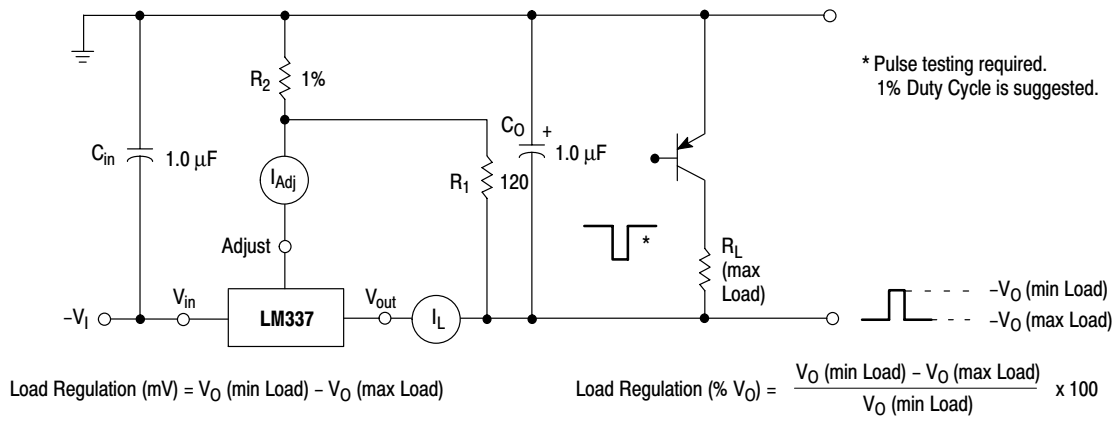

Figure 2. Load Regulation and ΔI_{Adj} /Load Test Circuit

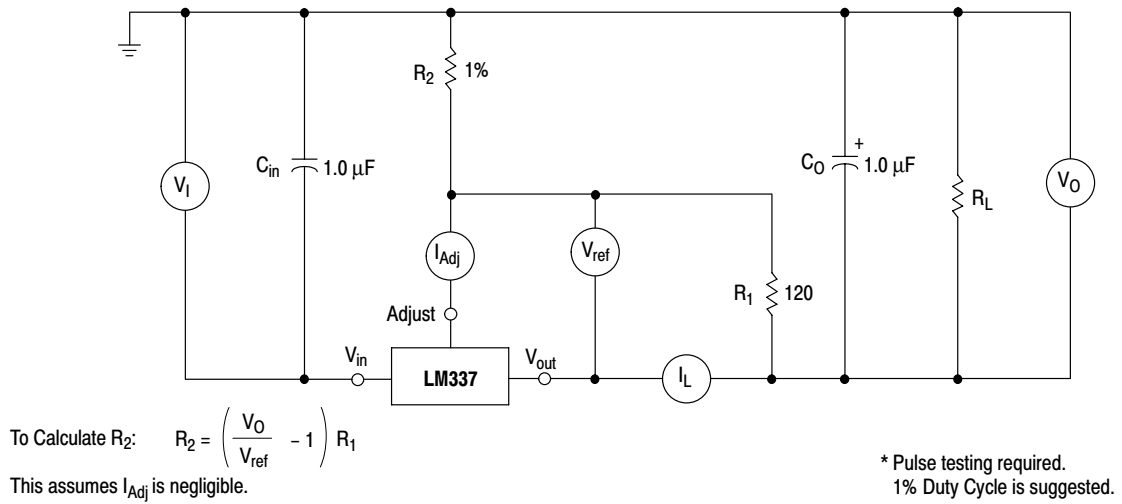

Figure 3. Standard Test Circuit

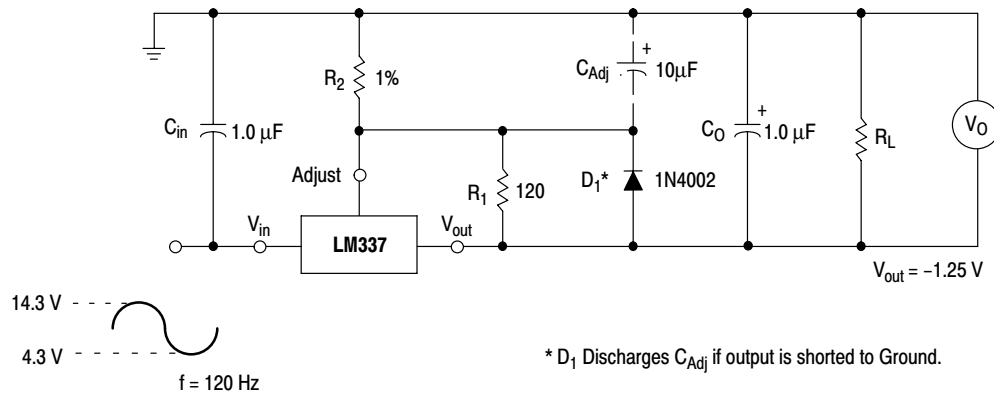

Figure 4. Ripple Rejection Test Circuit

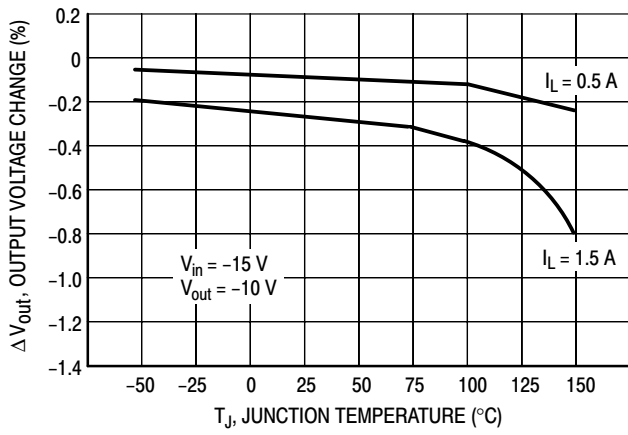

Figure 5. Load Regulation

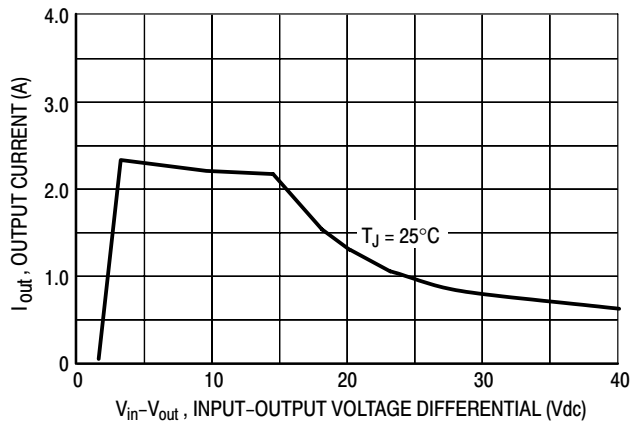

Figure 6. Current Limit

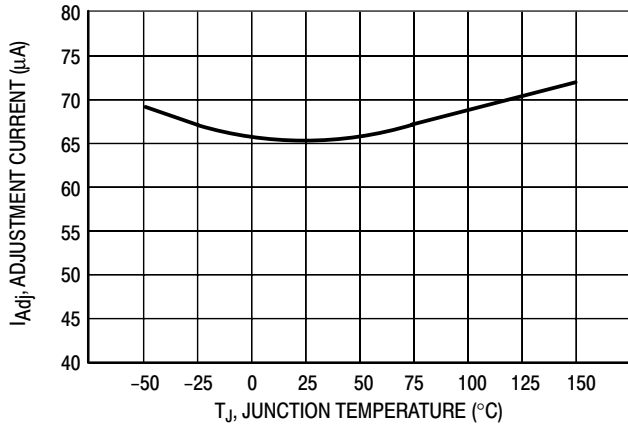

Figure 7. Adjustment Pin Current

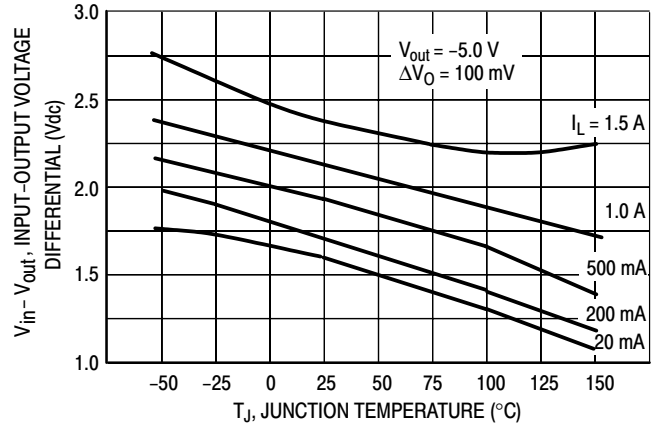

Figure 8. Dropout Voltage

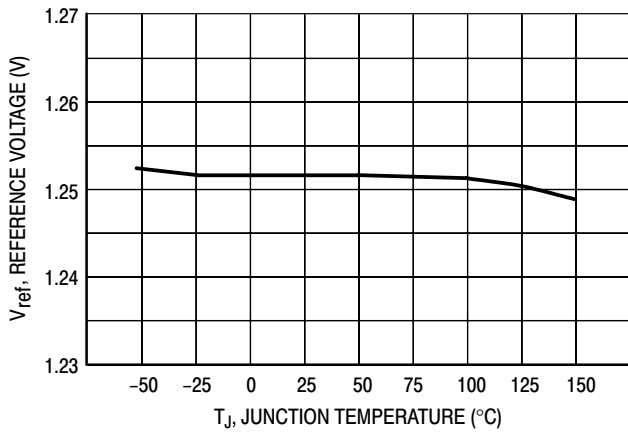

Figure 9. Temperature Stability

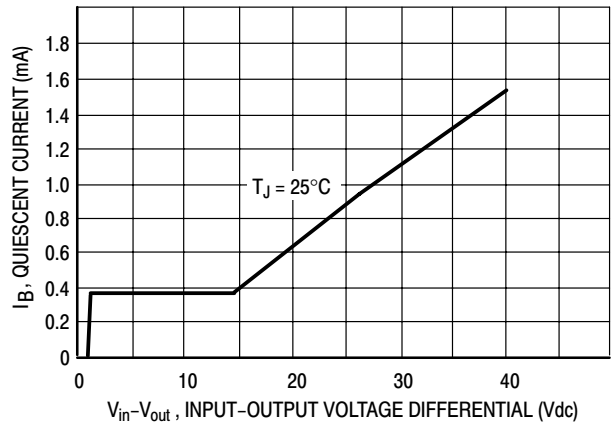

Figure 10. Minimum Operating Current

LM337

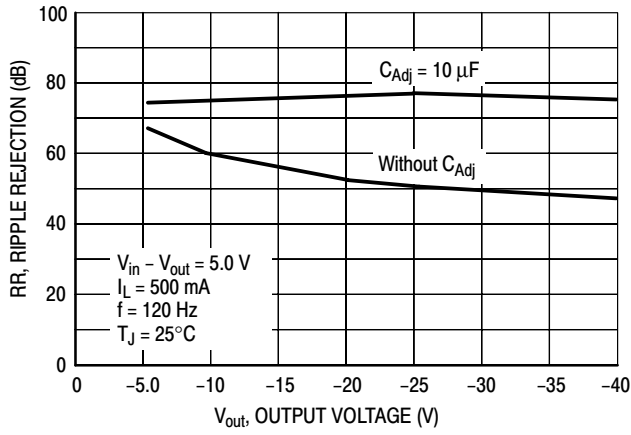

Figure 11. Ripple Rejection versus Output Voltage

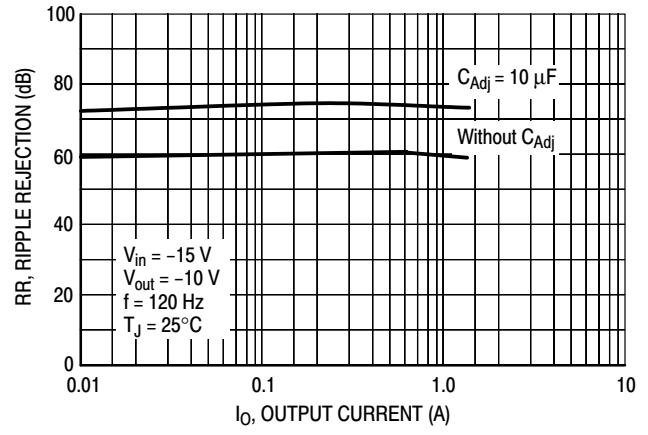

Figure 12. Ripple Rejection versus Output Current

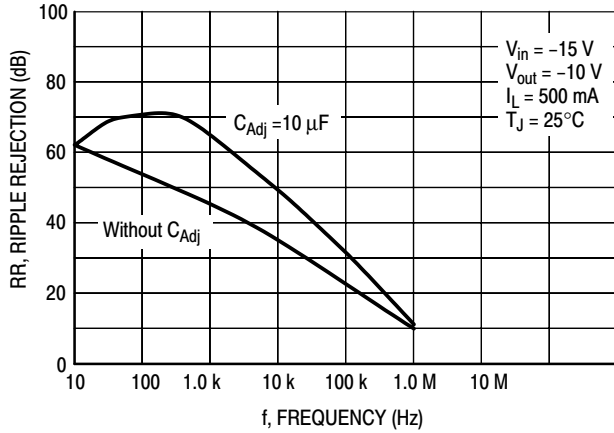

Figure 13. Ripple Rejection versus Frequency

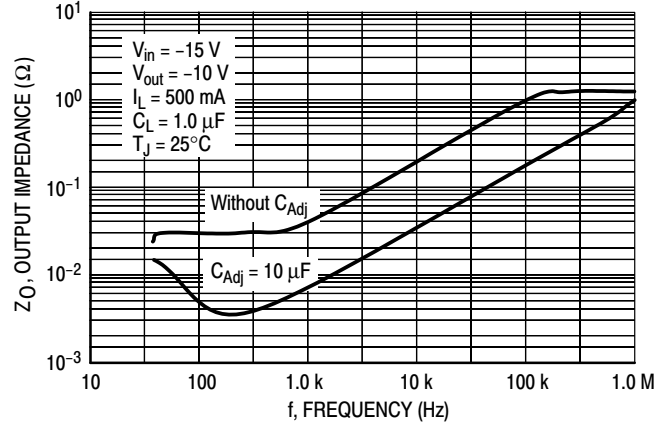

Figure 14. Output Impedance

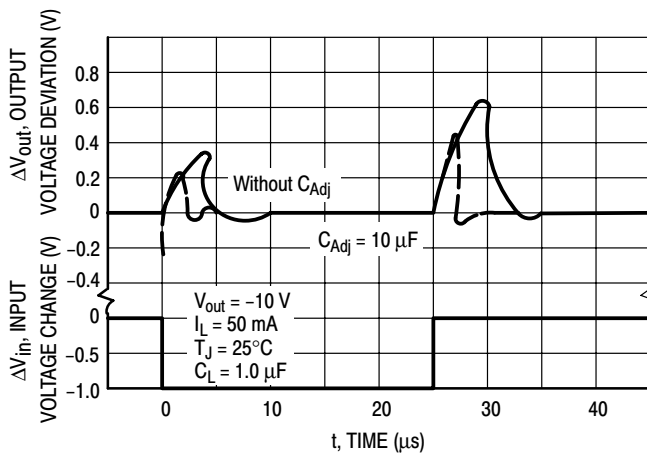

Figure 15. Line Transient Response

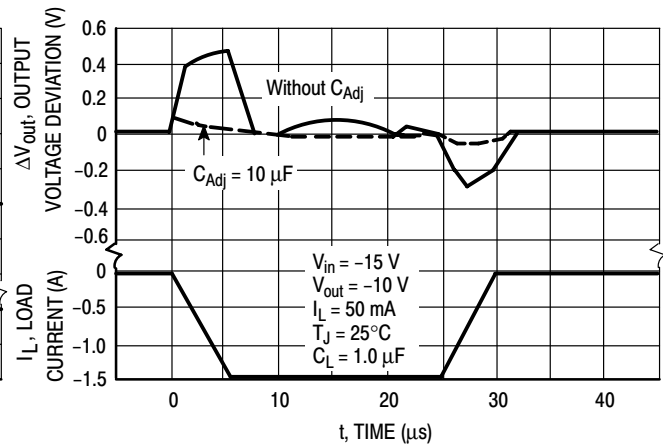

Figure 16. Load Transient Response

APPLICATIONS INFORMATION

Basic Circuit Operation

The LM337 is a 3-terminal floating regulator. In operation, the LM337 develops and maintains a nominal -1.25 V reference (V_{ref}) between its output and adjustment terminals. This reference voltage is converted to a programming current (I_{PROG}) by R_1 (see Figure 17), and this constant current flows through R_2 from ground.

The regulated output voltage is given by:

$$V_{out} = V_{ref} \left(1 + \frac{R_2}{R_1} \right) + I_{Adj} R_2$$

Since the current into the adjustment terminal (I_{Adj}) represents an error term in the equation, the LM337 was designed to control I_{Adj} to less than 100 μA and keep it constant. To do this, all quiescent operating current is returned to the output terminal. This imposes the requirement for a minimum load current. If the load current is less than this minimum, the output voltage will rise.

Since the LM337 is a floating regulator, it is only the voltage differential across the circuit which is important to performance, and operation at high voltages with respect to ground is possible.

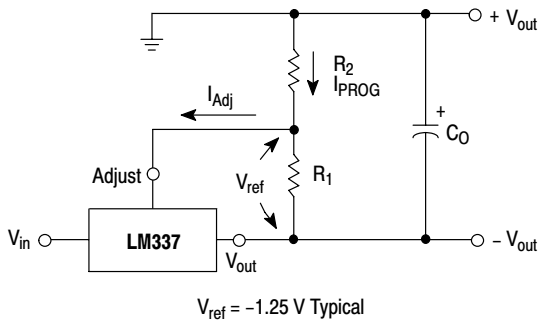

Figure 17. Basic Circuit Configuration

Load Regulation

The LM337 is capable of providing extremely good load regulation, but a few precautions are needed to obtain maximum performance. For best performance, the programming resistor (R_1) should be connected as close to the regulator as possible to minimize line drops which effectively appear in series with the reference, thereby

degrading regulation. The ground end of R_2 can be returned near the load ground to provide remote ground sensing and improve load regulation.

External Capacitors

A 1.0 μF tantalum input bypass capacitor (C_{in}) is recommended to reduce the sensitivity to input line impedance.

The adjustment terminal may be bypassed to ground to improve ripple rejection. This capacitor (C_{Adj}) prevents ripple from being amplified as the output voltage is increased. A 10 μF capacitor should improve ripple rejection about 15 dB at 120 Hz in a 10 V application.

An output capacitance (C_O) in the form of a 1.0 μF tantalum or 10 μF aluminum electrolytic capacitor is required for stability.

Protection Diodes

When external capacitors are used with any IC regulator it is sometimes necessary to add protection diodes to prevent the capacitors from discharging through low current points into the regulator.

Figure 18 shows the LM337 with the recommended protection diodes for output voltages in excess of -25 V or high capacitance values ($C_O > 25 \mu F$, $C_{Adj} > 10 \mu F$). Diode D_1 prevents C_O from discharging thru the IC during an input short circuit. Diode D_2 protects against capacitor C_{Adj} discharging through the IC during an output short circuit. The combination of diodes D_1 and D_2 prevents C_{Adj} from the discharging through the IC during an input short circuit.

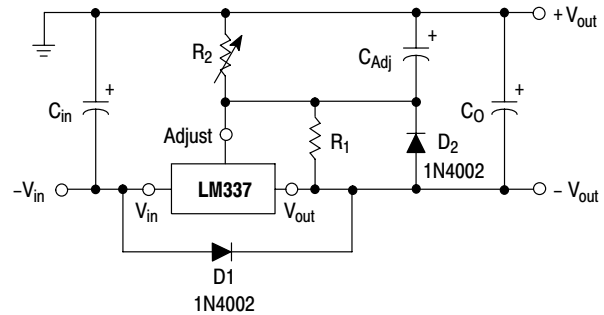

Figure 18. Voltage Regulator with Protection Diodes

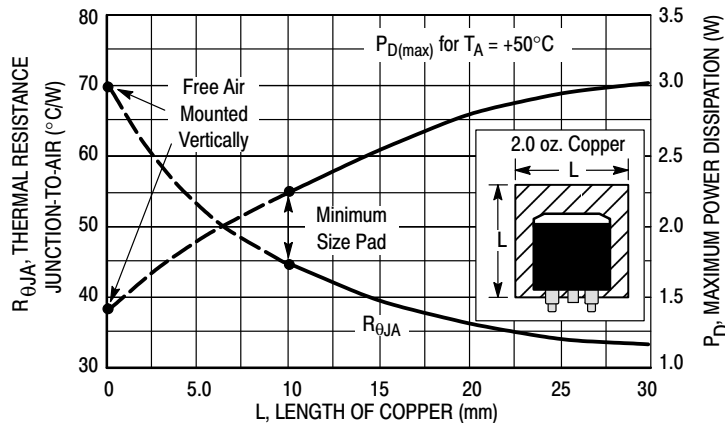
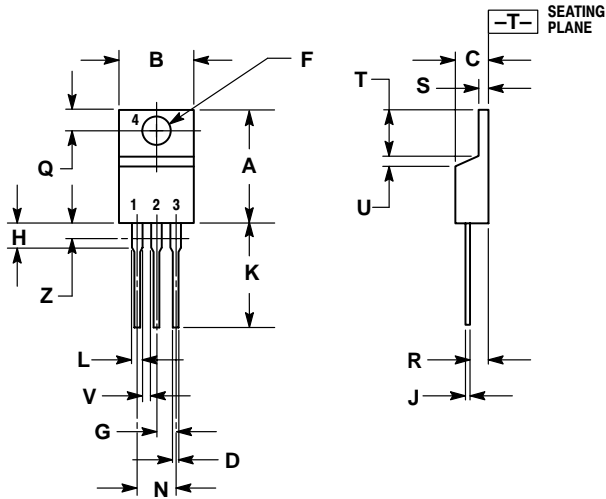

Figure 19. D²PAK Thermal Resistance and Maximum Power Dissipation versus P.C.B. Copper Length

LM337

PACKAGE DIMENSIONS

T SUFFIX
 PLASTIC PACKAGE
 CASE 221A-09
 ISSUE AA



- NOTES:
1. DIMENSIONING AND TOLERANCING PER ANSI Y14.5M, 1982.
 2. CONTROLLING DIMENSION: INCH.
 3. DIMENSION Z DEFINES A ZONE WHERE ALL BODY AND LEAD IRREGULARITIES ARE ALLOWED.

DIM	INCHES		MILLIMETERS	
	MIN	MAX	MIN	MAX
A	0.570	0.620	14.48	15.75
B	0.380	0.405	9.66	10.28
C	0.160	0.190	4.07	4.82
D	0.025	0.035	0.64	0.88
F	0.142	0.147	3.61	3.73
G	0.095	0.105	2.42	2.66
H	0.110	0.155	2.80	3.93
J	0.018	0.025	0.46	0.64
K	0.500	0.562	12.70	14.27
L	0.045	0.060	1.15	1.52
N	0.190	0.210	4.83	5.33
Q	0.100	0.120	2.54	3.04
R	0.080	0.110	2.04	2.79
S	0.045	0.055	1.15	1.39
T	0.235	0.255	5.97	6.47
U	0.000	0.050	0.00	1.27
V	0.045	---	1.15	---
Z	---	0.080	---	2.04

LM337

PACKAGE DIMENSIONS

D2T SUFFIX
PLASTIC PACKAGE
 CASE 936-03
 (D²PAK)
 ISSUE B

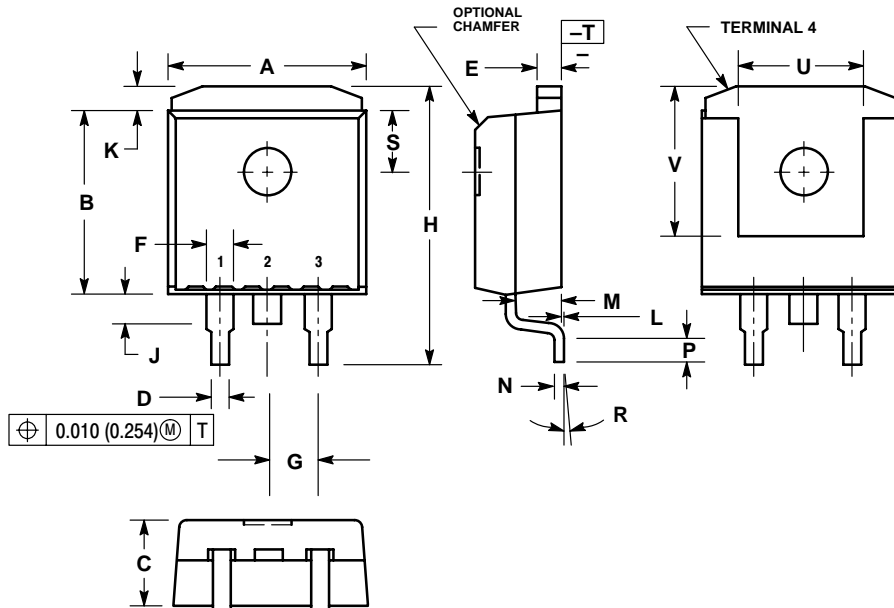

NOTES:

1. DIMENSIONING AND TOLERANCING PER ANSI Y14.5M, 1982.
2. CONTROLLING DIMENSION: INCH.
3. TAB CONTOUR OPTIONAL WITHIN DIMENSIONS A AND K.
4. DIMENSIONS U AND V ESTABLISH A MINIMUM MOUNTING SURFACE FOR TERMINAL 4.
5. DIMENSIONS A AND B DO NOT INCLUDE MOLD FLASH OR GATE PROTRUSIONS. MOLD FLASH AND GATE PROTRUSIONS NOT TO EXCEED 0.025 (0.635) MAXIMUM.

DIM	INCHES		MILLIMETERS	
	MIN	MAX	MIN	MAX
A	0.386	0.403	9.804	10.236
B	0.356	0.368	9.042	9.347
C	0.170	0.180	4.318	4.572
D	0.026	0.036	0.660	0.914
E	0.045	0.055	1.143	1.397
F	0.051 REF		1.295 REF	
G	0.100 BSC		2.540 BSC	
H	0.539	0.579	13.691	14.707
J	0.125 MAX		3.175 MAX	
K	0.050 REF		1.270 REF	
L	0.000	0.010	0.000	0.254
M	0.088	0.102	2.235	2.591
N	0.018	0.026	0.457	0.660
P	0.058	0.078	1.473	1.981
R	5° REF		5° REF	
S	0.116 REF		2.946 REF	
U	0.200 MIN		5.080 MIN	
V	0.250 MIN		6.350 MIN	

Notes

Notes

ON Semiconductor and  are trademarks of Semiconductor Components Industries, LLC (SCILLC). SCILLC reserves the right to make changes without further notice to any products herein. SCILLC makes no warranty, representation or guarantee regarding the suitability of its products for any particular purpose, nor does SCILLC assume any liability arising out of the application or use of any product or circuit, and specifically disclaims any and all liability, including without limitation special, consequential or incidental damages. "Typical" parameters which may be provided in SCILLC data sheets and/or specifications can and do vary in different applications and actual performance may vary over time. All operating parameters, including "Typicals" must be validated for each customer application by customer's technical experts. SCILLC does not convey any license under its patent rights nor the rights of others. SCILLC products are not designed, intended, or authorized for use as components in systems intended for surgical implant into the body, or other applications intended to support or sustain life, or for any other application in which the failure of the SCILLC product could create a situation where personal injury or death may occur. Should Buyer purchase or use SCILLC products for any such unintended or unauthorized application, Buyer shall indemnify and hold SCILLC and its officers, employees, subsidiaries, affiliates, and distributors harmless against all claims, costs, damages, and expenses, and reasonable attorney fees arising out of, directly or indirectly, any claim of personal injury or death associated with such unintended or unauthorized use, even if such claim alleges that SCILLC was negligent regarding the design or manufacture of the part. SCILLC is an Equal Opportunity/Affirmative Action Employer.

PUBLICATION ORDERING INFORMATION

Literature Fulfillment:

Literature Distribution Center for ON Semiconductor
P.O. Box 5163, Denver, Colorado 80217 USA
Phone: 303-675-2175 or 800-344-3860 Toll Free USA/Canada
Fax: 303-675-2176 or 800-344-3867 Toll Free USA/Canada
Email: ONlit@hibbertco.com

N. American Technical Support: 800-282-9855 Toll Free USA/Canada

JAPAN: ON Semiconductor, Japan Customer Focus Center
4-32-1 Nishi-Gotanda, Shinagawa-ku, Tokyo, Japan 141-0031
Phone: 81-3-5740-2700
Email: r14525@onsemi.com

ON Semiconductor Website: <http://onsemi.com>

For additional information, please contact your local Sales Representative.