

## Automatic AC Line Voltage Selector



**ON Semiconductor**  
Formerly a Division of Motorola  
<http://onsemi.com>

---

Prepared by: Alfredo Ochoa, Alex Lara & Gabriel Gonzalez  
Thyristors Applications Engineers

### APPLICATION NOTE

#### INTRODUCTION

In some cases, appliances and equipment are able to operate when supplied by two different levels of AC line voltage to their main terminals (120V or 240V). This is why, it is very common that appliances and equipment have mechanical selectors or switches as an option for selecting the level of voltage needed. Nevertheless, it is also very common that these types of equipment can suffer extensive damage caused for not putting the selector in the right position. To prevent these kind of problems, thyristors can be used as a solution for making automatic voltage selectors in order to avoid possibilities of equipment damage due to over or low voltages AC line supplied to them. Thyristors can take many forms, but they have certain things in common. All of them are solid state switches, which act as open circuits capable of withstanding the rated voltage until triggered. When they are triggered, thyristors become low impedance current paths and remain in that condition (i.e. conduction) until the current either stops or drops below a minimum value called the holding level. A useful application of triacs is a direct replacement for mechanical selectors, relays or switches. In this application, the triac furnishes on-off control and the power regulating ability of the triac is not utilized. The control circuitry for these applications is usually very simple and these circuits are useful in applications where simplicity and reliability are important. In addition, as is well known, there is no arcing

with the triac, which can also be very important in some applications.

The main disadvantages of the mechanical switches or selectors appear when they are driving high current levels that can cause arcing and sparks on their contacts each time they are activated or de-activated. Because of these kind of effects the contacts of the switches get very significantly damaged causing problems in the functionality of the equipment or appliances.

#### DEFINITIONS

**Control Transformers.** This transformer consists of two or more windings coupled by a common or mutual magnetic field. One of these windings, the primary, is connected to an alternating voltage source. An alternating flux will be produced whose amplitude will depend on the primary voltage and number of turns. The mutual flux will link the other winding, the secondary, in which it will induce a voltage whose value will depend on the number of secondary turns. When the numbers of primary and secondary turns are properly proportioned, almost any desired voltage ratio or ratio of transformation can be obtained. This transformer is also widely used in low power electronic and control circuits. There it performs such functions as matching the source impedance and its load for maximum power transfer, isolating one circuit from another, or isolating direct current while maintaining AC continuity between two circuits.

## AND8005/D

The following schematic diagram shows an automatic voltage selector for AC voltage supply of 110V/220V and

load of 10 Amp rms max. Loads can be equipment or any kind of appliances:

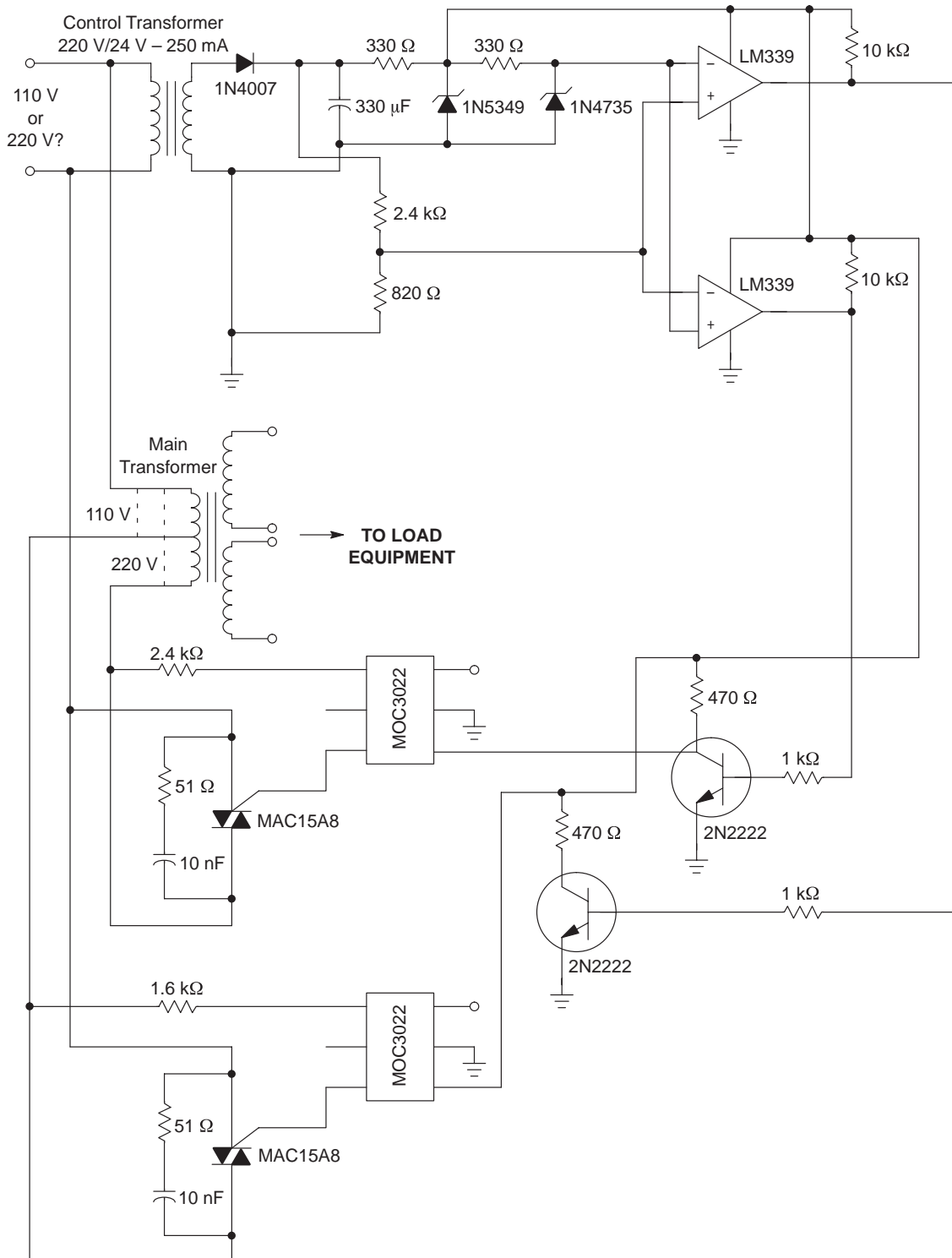

## AND8005/D

When the main terminals of the equipment are connected to the AC line voltage, one of the comparators (LM339) keeps its output at low level and the other one at high level because of the voltage references connected to their inverter and non-inverter input pins. Therefore, one of the transistors (2N2222) is activated allowing current through the LED of the optocoupler, and which triggers one of the triacs (MAC15A8) that then provides the right level of AC line voltage to the main transformer of the equipment by connecting one of the primary windings through the triac triggered.

The operational range, in the previous circuit, in the low AC line voltage condition (110V) is from 100 Vrms to 150 Vrms. This means, the triac that is driving the winding of the main transformer for 110V would keep itself triggered whenever the input voltage in the control transformer is within 100 and 150 Vrms. The operation range in high AC

line voltage condition (220V) is from 180 Vrms to 250 Vrms, therefore, the triac that is driving the winding of the main transformer for 220V would keep itself triggered whenever the voltage in the control transformer is within 180 and 250 Vrms. Another very important item to take into consideration is the operational range of environmental temperature which is from 0°C to 65°C. If the circuit is working outside of these temperature limits, it very probably will experience unreliable functionality.

In conclusion, this automatic voltage selector provides a very important protection for any kind of voltage sensitive equipment or appliances against the wrong levels of AC line input voltages. It eliminates the possibility of any damage in the circuitry of the equipment caused by connecting low or high voltage to the main terminals. In addition, the total price of the electronic circuitry is inexpensive when compared to the cost of the equipment if it suffers any damage.

**ON Semiconductor** and  are trademarks of Semiconductor Components Industries, LLC (SCILLC). SCILLC reserves the right to make changes without further notice to any products herein. SCILLC makes no warranty, representation or guarantee regarding the suitability of its products for any particular purpose, nor does SCILLC assume any liability arising out of the application or use of any product or circuit, and specifically disclaims any and all liability, including without limitation special, consequential or incidental damages. "Typical" parameters which may be provided in SCILLC data sheets and/or specifications can and do vary in different applications and actual performance may vary over time. All operating parameters, including "Typicals" must be validated for each customer application by customer's technical experts. SCILLC does not convey any license under its patent rights nor the rights of others. SCILLC products are not designed, intended, or authorized for use as components in systems intended for surgical implant into the body, or other applications intended to support or sustain life, or for any other application in which the failure of the SCILLC product could create a situation where personal injury or death may occur. Should Buyer purchase or use SCILLC products for any such unintended or unauthorized application, Buyer shall indemnify and hold SCILLC and its officers, employees, subsidiaries, affiliates, and distributors harmless against all claims, costs, damages, and expenses, and reasonable attorney fees arising out of, directly or indirectly, any claim of personal injury or death associated with such unintended or unauthorized use, even if such claim alleges that SCILLC was negligent regarding the design or manufacture of the part. SCILLC is an Equal Opportunity/Affirmative Action Employer.

## PUBLICATION ORDERING INFORMATION

### USA/EUROPE Literature Fulfillment:

Literature Distribution Center for ON Semiconductor  
P.O. Box 5163, Denver, Colorado 80217 USA  
**Phone:** 303-675-2175 or 800-344-3860 Toll Free USA/Canada  
**Fax:** 303-675-2176 or 800-344-3867 Toll Free USA/Canada  
**Email:** ONlit@hibbertco.com

**Fax Response Line\*:** 303-675-2167  
800-344-3810 Toll Free USA/Canada  
\*To receive a Fax of our publications

**N. America Technical Support:** 800-282-9855 Toll Free USA/Canada

### ASIA/PACIFIC: LDC for ON Semiconductor – Asia Support

**Phone:** 303-675-2121 (Tue-Fri 9:00am to 1:00pm, Hong Kong Time)  
**Email:** ONlit-asia@hibbertco.com

**JAPAN:** ON Semiconductor, Japan Customer Focus Center  
4-32-1 Nishi-Gotanda, Shinagawa-ku, Tokyo, Japan 141-8549

**Phone:** 81-3-5487-8345  
**Email:** r14153@onsemi.com

**ON Semiconductor Website:** <http://onsemi.com>

For additional information, please contact your local Sales Representative.