

# MC10E137, MC100E137

## 5V ECL 8-Bit Ripple Counter

The MC10E/100E137 is a very high speed binary ripple counter. The two least significant bits were designed with very fast edge rates while the more significant bits maintain standard ECLinPS™ output edge rates. This allows the counter to operate at very high frequencies while maintaining a moderate power dissipation level.

The device is ideally suited for multiple frequency clock generation as well as a counter in a high performance ATE time measurement board.

Both asynchronous and synchronous enables are available to maximize the device's flexibility for various applications. The asynchronous enable input, A\_Start, when asserted enables the counter while overriding any synchronous enable signals. The E137 features XORed enable inputs, EN1 and EN2, which are synchronous to the CLK input. When only one synchronous enable is asserted the counter becomes disabled on the next CLK transition; all outputs remain in the previous state poised for the other synchronous enable or A\_Start to be asserted to re-enable the counter. Asserting both synchronous enables causes the counter to become enabled on the next transition of the CLK. If EN1 (or EN2) and CLK edges are coincident, sufficient delay has been inserted in the CLK path (to compensate for the XOR gate delay and the internal D-flip flop setup time) to insure that the synchronous enable signal is clocked correctly, hence, the counter is disabled.

All input pins left open will be pulled LOW via an input pulldown resistor. Therefore, do not leave the differential CLK inputs open. Doing so causes the current source transistor of the input clock gate to become saturated, thus upsetting the internal bias regulators and jeopardizing the stability of the device.

The asynchronous Master Reset resets the counter to an all zero state upon assertion.

The V<sub>BB</sub> pin, an internally generated voltage supply, is available to this device only. For single-ended input conditions, the unused differential input is connected to V<sub>BB</sub> as a switching reference voltage. V<sub>BB</sub> may also rebias AC coupled inputs. When used, decouple V<sub>BB</sub> and V<sub>CC</sub> via a 0.01 μF capacitor and limit current sourcing or sinking to 0.5 mA. When not used, V<sub>BB</sub> should be left open.

The 100 Series contains temperature compensation.

- Differential Clock Input and Data Output Pins
- V<sub>BB</sub> Output for Single-Ended Use
- Synchronous and Asynchronous Enable Pins
- Asynchronous Master Reset
- PECL Mode Operating Range: V<sub>CC</sub>= 4.2 V to 5.7 V with V<sub>EE</sub>= 0 V
- NECL Mode Operating Range: V<sub>CC</sub>= 0 V with V<sub>EE</sub>= -4.2 V to -5.7 V
- Internal Input 50 KΩ Pull-down Resistors
- ESD Protection: > 2 KV HBM, > 100 V MM
- Meets or Exceeds JEDEC Spec EIA/JESD78 IC Latchup Test
- Moisture Sensitivity Level 1  
For Additional Information, see Application Note AND8003/D
- Flammability Rating: UL 94 V-0 @ 0.125 in,  
Oxygen Index: 28 to 34
- Transistor Count = 330 devices



ON Semiconductor®

<http://onsemi.com>

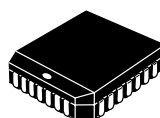

PLCC-28  
FN SUFFIX  
CASE 776

### MARKING DIAGRAMS

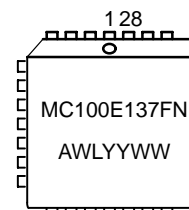
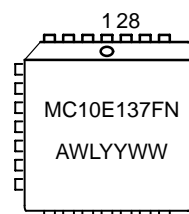

A = Assembly Location  
WL = Wafer Lot  
YY = Year  
WW = Work Week

### ORDERING INFORMATION

Device	Package	Shipping†
MC10E137FN	PLCC-28	37 Units/Rail
MC10E137FNR2	PLCC-28	500 / Tape & Reel
MC100E137FN	PLCC-28	37 Units/Rail
MC100E137FNR2	PLCC-28	500 / Tape & Reel

†For information on tape and reel specifications, including part orientation and tape sizes, please refer to our Tape and Reel Packaging Specifications Brochure, BRD8011/D.

# MC10E137, MC100E137

## PIN DESCRIPTION

PIN	FUNCTION
CLK, $\overline{\text{CLK}}$	ECL Differential Clock Inputs
Q0-Q7, $\overline{\text{Q0-Q7}}$	ECL Differential Q Outputs
A_Start	ECL Asynchronous Enable Input
EN1, EN2	ECL Synchronous Enable Inputs
MR	Asynchronous Master Reset
V <sub>BB</sub>	Reference Voltage Output
V <sub>CC</sub> , V <sub>CCO</sub>	Positive Supply
V <sub>EE</sub>	Negative Supply

Warning: All V<sub>CC</sub>, V<sub>CCO</sub>, and V<sub>EE</sub> pins must be externally connected to Power Supply to guarantee proper operation.

## LOGIC DIAGRAM AND PINOUT ASSIGNMENT

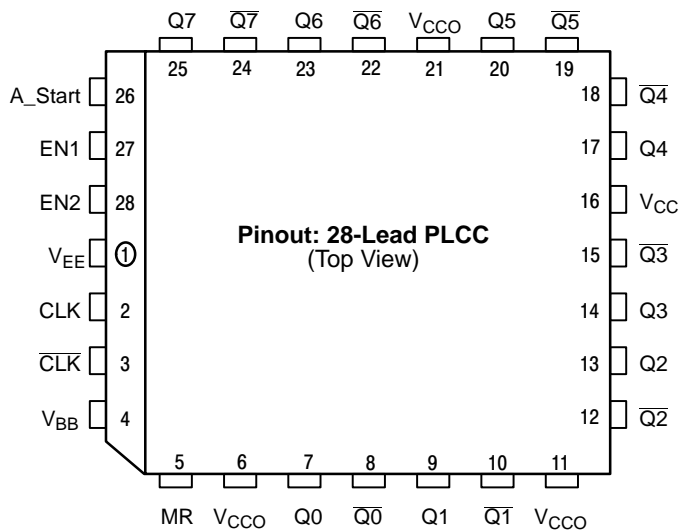

\* All V<sub>CC</sub> and V<sub>CCO</sub> pins are tied together on the die.

## LOGIC DIAGRAM

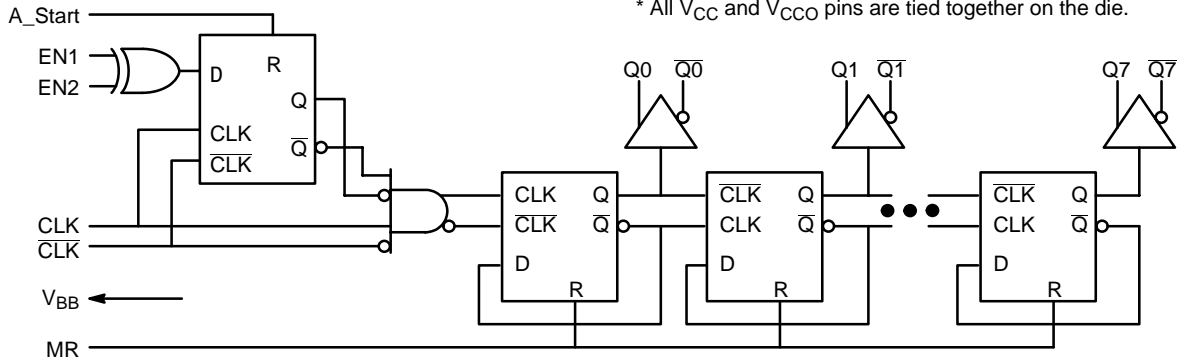

## SEQUENTIAL TRUTH TABLE

Function	EN1	EN2	A_Start	MR	CLK	Q7	Q6	Q5	Q4	Q3	Q2	Q1	Q0
Reset	X	X	X	H	X	L	L	L	L	L	L	L	L
Count	L	L	L	L	Z	L	L	L	L	L	L	L	H
	L	L	L	L	Z	L	L	L	L	L	L	H	L
	L	L	L	L	Z	L	L	L	L	L	L	H	H
Stop	H	L	L	L	Z	L	L	L	L	L	L	H	H
	H	L	L	L	Z	L	L	L	L	L	L	H	H
Asynch Start	H	L	H	L	Z	L	L	L	L	L	H	L	L
	H	L	H	L	Z	L	L	L	L	L	H	L	H
	L	L	H	L	Z	L	L	L	L	L	H	H	L
Count	L	L	L	L	Z	L	L	L	L	L	H	H	H
	L	L	L	L	Z	L	L	L	L	H	L	L	L
	L	L	L	L	Z	L	L	L	L	H	L	L	H
Stop	L	H	L	L	Z	L	L	L	L	H	L	L	H
	L	H	L	L	Z	L	L	L	L	H	L	L	H
Synch Start	H	H	L	L	Z	L	L	L	L	H	L	H	L
	H	H	L	L	Z	L	L	L	L	H	L	H	H
	H	H	L	L	Z	L	L	L	L	H	H	L	L
Stop	H	L	L	L	Z	L	L	L	L	H	H	L	L
	H	L	L	L	Z	L	L	L	L	H	H	L	L
	H	L	L	L	Z	L	L	L	L	H	H	L	L
Count	L	L	L	L	Z	L	L	L	L	H	H	L	H
	L	L	L	L	Z	L	L	L	L	H	H	H	L
	L	L	L	L	Z	L	L	L	L	H	H	H	H
Reset	X	X	X	H	X	L	L	L	L	L	L	L	L

Z = Low to High Transition

# MC10E137, MC100E137

## MAXIMUM RATINGS (Note 1)

Symbol	Parameter	Condition 1	Condition 2	Rating	Unit
V <sub>CC</sub>	PECL Mode Power Supply	V <sub>EE</sub> = 0 V		8	V
V <sub>EE</sub>	NECL Mode Power Supply	V <sub>CC</sub> = 0 V		-8	V
V <sub>I</sub>	PECL Mode Input Voltage NECL Mode Input Voltage	V <sub>EE</sub> = 0 V V <sub>CC</sub> = 0 V	V <sub>I</sub> ≤ V <sub>CC</sub> V <sub>I</sub> ≥ V <sub>EE</sub>	6 -6	V V
I <sub>out</sub>	Output Current	Continuous Surge		50 100	mA mA
I <sub>BB</sub>	V <sub>BB</sub> Sink/Source			± 0.5	mA
T <sub>A</sub>	Operating Temperature Range			0 to +85	°C
T <sub>stg</sub>	Storage Temperature Range			-65 to +150	°C
θ <sub>JA</sub>	Thermal Resistance (Junction to Ambient)	0 LFPM 500 LFPM	28 PLCC 28 PLCC	63.5 43.5	°C/W °C/W
θ <sub>JC</sub>	Thermal Resistance (Junction to Case)	Standard Board	28 PLCC	22 to 26	°C/W
V <sub>EE</sub>	PECL Operating Range NECL Operating Range			4.2 to 5.7 -5.7 to -4.2	V V
T <sub>sol</sub>	Wave Solder	<2 to 3 sec @ 248°C		265	°C

1. Maximum Ratings are those values beyond which device damage may occur.

## 10E SERIES PECL DC CHARACTERISTICS V<sub>CCx</sub>= 5.0 V; V<sub>EE</sub>= 0.0 V (Note 2)

Symbol	Characteristic	0°C			25°C			85°C			Unit
		Min	Typ	Max	Min	Typ	Max	Min	Typ	Max	
I <sub>EE</sub>	Power Supply Current		121	145		121	145		121	145	mA
V <sub>OH</sub>	Output HIGH Voltage (Note 3)	3980	4070	4160	4020	4105	4190	4090	4185	4280	mV
V <sub>OL</sub>	Output LOW Voltage (Note 3)	3050	3210	3370	3050	3210	3370	3050	3227	3405	mV
V <sub>IH</sub>	Input HIGH Voltage (Single Ended)	3830	3995	4160	3870	4030	4190	3940	4110	4280	mV
V <sub>IL</sub>	Input LOW Voltage (Single Ended)	3050	3285	3520	3050	3285	3520	3050	3302	3555	mV
V <sub>BB</sub>	Output Voltage Reference	3.62		3.73	3.65		3.75	3.69		3.81	V
V <sub>IHCMR</sub>	Input HIGH Voltage Common Mode Range (Differential) (Note 4)	2.2		4.6	2.2		4.6	2.2		4.6	V
I <sub>IH</sub>	Input HIGH Current			150			150			150	μA
I <sub>IL</sub>	Input LOW Current	0.5	0.3		0.5	0.25		0.3	0.2		μA

NOTE: Devices are designed to meet the DC specifications shown in the above table, after thermal equilibrium has been established.

The circuit is in a test socket or mounted on a printed circuit board and transverse air flow greater than 500 lfm is maintained.

- Input and output parameters vary 1:1 with V<sub>CC</sub>. V<sub>EE</sub> can vary -0.46 V / +0.06 V.
- Outputs are terminated through a 50 Ω resistor to V<sub>CC</sub> - 2 volts.
- V<sub>IHCMR</sub> min varies 1:1 with V<sub>EE</sub>, max varies 1:1 with V<sub>CC</sub>.

# MC10E137, MC100E137

## 10E SERIES NECL DC CHARACTERISTICS $V_{CCx}= 0.0\text{ V}$ ; $V_{EE}=-5.0\text{ V}$ (Note 5)

Symbol	Characteristic	0°C			25°C			85°C			Unit
		Min	Typ	Max	Min	Typ	Max	Min	Typ	Max	
$I_{EE}$	Power Supply Current		121	145		121	145		121	145	mA
$V_{OH}$	Output HIGH Voltage (Note 6)	-1020	-930	-840	-980	-895	-810	-910	-815	-720	mV
$V_{OL}$	Output LOW Voltage (Note 6)	-1950	-1790	-1630	-1950	-1790	-1630	-1950	-1773	-1595	mV
$V_{IH}$	Input HIGH Voltage (Single Ended)	-1170	-1005	-840	-1130	-970	-810	-1060	-890	-720	mV
$V_{IL}$	Input LOW Voltage (Single Ended)	-1950	-1715	-1480	-1950	-1715	-1480	-1950	-1698	-1445	mV
$V_{BB}$	Output Voltage Reference	-1.38		-1.27	-1.35		-1.25	-1.31		-1.19	V
$V_{IHCMR}$	Input HIGH Voltage Common Mode Range (Differential) (Note 7)	-2.8		-0.4	-2.8		-0.4	-2.8		-0.4	V
$I_{IH}$	Input HIGH Current			150			150			150	$\mu\text{A}$
$I_{IL}$	Input LOW Current	0.5	0.3		0.5	0.065		0.3	0.2		$\mu\text{A}$

NOTE: Devices are designed to meet the DC specifications shown in the above table, after thermal equilibrium has been established.

The circuit is in a test socket or mounted on a printed circuit board and transverse air flow greater than 500 lfpm is maintained.

5. Input and output parameters vary 1:1 with  $V_{CC}$ .  $V_{EE}$  can vary  $-0.46\text{ V} / +0.06\text{ V}$ .
6. Outputs are terminated through a  $50\ \Omega$  resistor to  $V_{CC} - 2\text{ V}$ .
7.  $V_{IHCMR}$  min varies 1:1 with  $V_{EE}$ , max varies 1:1 with  $V_{CC}$ .

## 100E SERIES PECL DC CHARACTERISTICS $V_{CCx}= 5.0\text{ V}$ ; $V_{EE}= 0.0\text{ V}$ (Note 8)

Symbol	Characteristic	0°C			25°C			85°C			Unit
		Min	Typ	Max	Min	Typ	Max	Min	Typ	Max	
$I_{EE}$	Power Supply Current		121	145		121	145		139	167	mA
$V_{OH}$	Output HIGH Voltage (Note 9)	3975	4050	4120	3975	4050	4120	3975	4050	4120	mV
$V_{OL}$	Output LOW Voltage (Note 9)	3190	3295	3380	3190	3255	3380	3190	3260	3380	mV
$V_{IH}$	Input HIGH Voltage (Single-Ended)	3835	3975	4120	3835	3975	4120	3835	3975	4120	mV
$V_{IL}$	Input LOW Voltage (Single-Ended)	3190	3355	3525	3190	3355	3525	3190	3355	3525	mV
$V_{BB}$	Output Voltage Reference	3.62		3.73	3.62		3.74	3.62		3.74	V
$V_{IHCMR}$	Input HIGH Voltage Common Mode Range (Differential) (Note 10)	2.2		4.6	2.2		4.6	2.2		4.6	V
$I_{IH}$	Input HIGH Current			150			150			150	$\mu\text{A}$
$I_{IL}$	Input LOW Current	0.5	0.3		0.5	0.25		0.5	0.2		$\mu\text{A}$

NOTE: Devices are designed to meet the DC specifications shown in the above table, after thermal equilibrium has been established.

The circuit is in a test socket or mounted on a printed circuit board and transverse air flow greater than 500 lfpm is maintained.

8. Input and output parameters vary 1:1 with  $V_{CC}$ .  $V_{EE}$  can vary  $-0.46\text{ V} / +0.8\text{ V}$ .
9. Outputs are terminated through a  $50\ \Omega$  resistor to  $V_{CC} - 2\text{ V}$ .
10.  $V_{IHCMR}$  min varies 1:1 with  $V_{EE}$ , max varies 1:1 with  $V_{CC}$ .

# MC10E137, MC100E137

## 100E SERIES NECL DC CHARACTERISTICS $V_{CCx}=0.0\text{ V}$ ; $V_{EE}=-5.0\text{ V}$ (Note 11)

Symbol	Characteristic	0°C			25°C			85°C			Unit
		Min	Typ	Max	Min	Typ	Max	Min	Typ	Max	
$I_{EE}$	Power Supply Current		121	145		121	145		139	167	mA
$V_{OH}$	Output HIGH Voltage (Note 12)	-1025	-950	-880	-1025	-950	-880	-1025	-950	-880	mV
$V_{OL}$	Output LOW Voltage (Note 12)	-1810	-1705	-1620	-1810	-1745	-1620	-1810	-1740	-1620	mV
$V_{IH}$	Input HIGH Voltage (Single Ended)	-1165	-1025	-880	-1165	-1025	-880	-1165	-1025	-880	mV
$V_{IL}$	Input LOW Voltage (Single Ended)	-1810	-1645	-1475	-1810	-1645	-1475	-1810	-1645	-1475	mV
$V_{BB}$	Output Voltage Reference	-1.38		-1.27	-1.38		-1.26	-1.38		-1.26	V
$V_{IHCMR}$	Input HIGH Voltage Common Mode Range (Differential) (Note 13)	-3.8		-0.4	-3.8		-0.4	-3.8		-0.4	V
$I_{IH}$	Input HIGH Current			150			150			150	$\mu\text{A}$
$I_{IL}$	Input LOW Current	0.5	0.3		0.5	0.25		0.5	0.2		$\mu\text{A}$

NOTE: Devices are designed to meet the DC specifications shown in the above table, after thermal equilibrium has been established. The circuit is in a test socket or mounted on a printed circuit board and transverse air flow greater than 500 lfm is maintained.

11. Input and output parameters vary 1:1 with  $V_{CC}$ .  $V_{EE}$  can vary  $-0.46\text{ V} / +0.8\text{ V}$ .

12. Outputs are terminated through a  $50\ \Omega$  resistor to  $V_{CC} - 2\text{ V}$ .

13.  $V_{IHCMR}$  min varies 1:1 with  $V_{EE}$ , max varies 1:1 with  $V_{CC}$ .

## AC CHARACTERISTICS $V_{CCx}=5.0\text{ V}$ ; $V_{EE}=0.0\text{ V}$ or $V_{CCx}=0.0\text{ V}$ ; $V_{EE}=-5.0\text{ V}$ (Note 14)

Symbol	Characteristic	0°C			25°C			85°C			Unit
		Min	Typ	Max	Min	Typ	Max	Min	Typ	Max	
$f_{\text{COUNT}}$	Maximum Count Frequency	1800	2200		1800	2200		1800	2200		MHz
$t_{\text{PLH}}$ $t_{\text{PHL}}$	Propagation Delay to Output										ps
	CLK to Q0	1300	1700	2150	1300	1700	2150	1350	1750	2200	
	CLK to Q1	1600	2025	2500	1600	2050	2500	1650	2100	2550	
	CLK to Q2	1950	2425	2925	1950	2450	2925	2025	2500	3000	
	CLK to Q3	2275	2750	3350	2275	2775	3350	2350	2850	3425	
	CLK to Q4	2625	3125	3750	2625	3150	3750	2700	3225	3825	
	CLK to Q5	2950	3450	4150	2950	3475	4150	3050	3550	4250	
	CLK to Q6	3250	3775	4450	3250	3800	4450	3375	3925	4600	
	CLK to Q7	3575	4075	4800	3575	4125	4800	3700	4250	4950	
	A_Start to Q0	950	1325	1700	950	1325	1700	950	1325	1700	
	MR to Q0	700	1000	1300	700	1000	1300	700	1000	1300	
$t_s$	Setup Time (EN1, EN2)	0	-150		0	-150		0	-150		ps
$t_h$	Hold Time (EN1, EN2)	300	150		300	150		300	150		ps
$t_{\text{RR}}$	Reset Recovery Time										ps
	MR, A_Start	400	200		400	200		400	200		
$t_{\text{PW}}$	Minimum Pulse Width										ps
	CLK, MR, A_Start	400			400			400			
$V_{\text{PP}}$	Input Voltage Swing CLK/ $\overline{\text{CLK}}$ (Differential Configuration) (Note 15)	0.25		1.0	0.25		1.0	0.25		1.0	V
$t_{\text{JITTER}}$	Random Clock Jitter (RMS)		< 1			< 1			< 1		ps
$t_r$ $t_f$	Rise/Fall Times (20%–80%)										ps
	Q0, Q1	150		400	150		400	150		400	
	Q2 to Q7	275		600	275		600	275		600	

14. 10 Series:  $V_{EE}$  can vary  $-0.46\text{ V} / +0.06\text{ V}$ .

100 Series:  $V_{EE}$  can vary  $-0.46\text{ V} / +0.8\text{ V}$ .

15. Minimum input swing for which AC parameters are guaranteed. Full DC ECL output swings will be generated with only 50 mV input swings.

## MC10E137, MC100E137

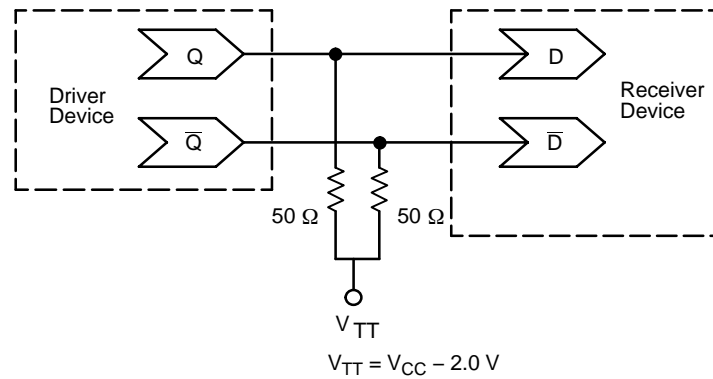

**Figure 1. Typical Termination for Output Driver and Device Evaluation**  
(See Application Note AND8020 – Termination of ECL Logic Devices.)

### Resource Reference of Application Notes

- AN1404** – ECLinPS Circuit Performance at Non-Standard  $V_{IH}$  Levels
- AN1405** – ECL Clock Distribution Techniques
- AN1406** – Designing with PECL (ECL at +5.0 V)
- AN1503** – ECLinPS I/O SPICE Modeling Kit
- AN1504** – Metastability and the ECLinPS Family
- AN1568** – Interfacing Between LVDS and ECL
- AN1596** – ECLinPS Lite Translator ELT Family SPICE I/O Model Kit
- AN1650** – Using Wire-OR Ties in ECLinPS Designs
- AN1672** – The ECL Translator Guide
- AND8001** – Odd Number Counters Design
- AND8002** – Marking and Date Codes
- AND8020** – Termination of ECL Logic Devices

# MC10E137, MC100E137

## PACKAGE DIMENSIONS

PLCC-28  
FN SUFFIX  
PLASTIC PLCC PACKAGE  
CASE 776-02  
ISSUE E

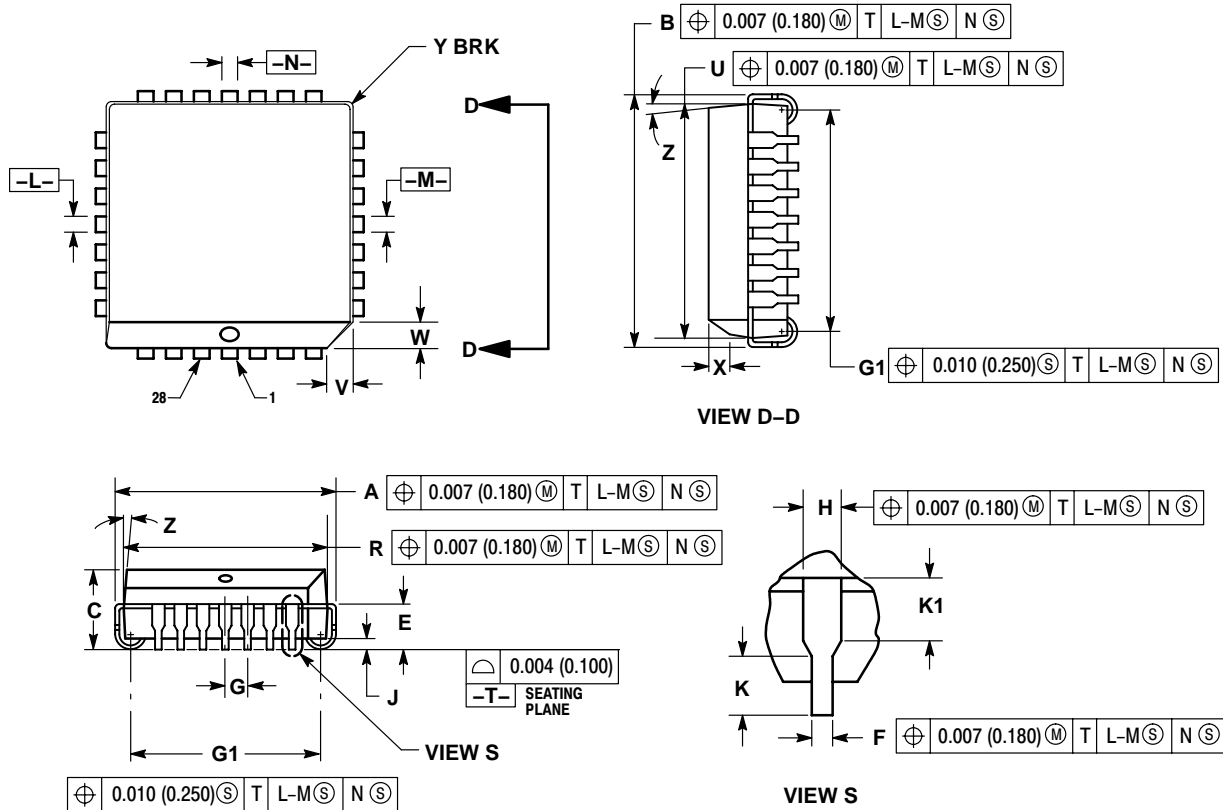

### NOTES:

- DATUMS -L-, -M-, AND -N- DETERMINED WHERE TOP OF LEAD SHOULDER EXITS PLASTIC BODY AT MOLD PARTING LINE.
- DIMENSION G1, TRUE POSITION TO BE MEASURED AT DATUM -T-, SEATING PLANE.
- DIMENSIONS R AND U DO NOT INCLUDE MOLD FLASH. ALLOWABLE MOLD FLASH IS 0.010 (0.250) PER SIDE.
- DIMENSIONING AND TOLERANCING PER ANSI Y14.5M, 1982.
- CONTROLLING DIMENSION: INCH.
- THE PACKAGE TOP MAY BE SMALLER THAN THE PACKAGE BOTTOM BY UP TO 0.012 (0.300). DIMENSIONS R AND U ARE DETERMINED AT THE OUTERMOST EXTREMES OF THE PLASTIC BODY EXCLUSIVE OF MOLD FLASH, TIE BAR BURRS, GATE BURRS AND INTERLEAD FLASH, BUT INCLUDING ANY MISMATCH BETWEEN THE TOP AND BOTTOM OF THE PLASTIC BODY.
- DIMENSION H DOES NOT INCLUDE DAMBAR PROTRUSION OR INTRUSION. THE DAMBAR PROTRUSION(S) SHALL NOT CAUSE THE H DIMENSION TO BE GREATER THAN 0.037 (0.940). THE DAMBAR INTRUSION(S) SHALL NOT CAUSE THE H DIMENSION TO BE SMALLER THAN 0.025 (0.635).

DIM	INCHES		MILLIMETERS	
	MIN	MAX	MIN	MAX
A	0.485	0.495	12.32	12.57
B	0.485	0.495	12.32	12.57
C	0.165	0.180	4.20	4.57
E	0.090	0.110	2.29	2.79
F	0.013	0.019	0.33	0.48
G	0.050 BSC		1.27 BSC	
H	0.026	0.032	0.66	0.81
J	0.020	---	0.51	---
K	0.025	---	0.64	---
R	0.450	0.456	11.43	11.58
U	0.450	0.456	11.43	11.58
V	0.042	0.048	1.07	1.21
W	0.042	0.048	1.07	1.21
X	0.042	0.056	1.07	1.42
Y	---	0.020	---	0.50
Z	2°		10°	
G1	0.410	0.430	10.42	10.92
K1	0.040	---	1.02	---

# MC10E137, MC100E137

ECLinPS is a trademarks of Semiconductor Components Industries, LLC (SCILLC).

**ON Semiconductor** and  are registered trademarks of Semiconductor Components Industries, LLC (SCILLC). SCILLC reserves the right to make changes without further notice to any products herein. SCILLC makes no warranty, representation or guarantee regarding the suitability of its products for any particular purpose, nor does SCILLC assume any liability arising out of the application or use of any product or circuit, and specifically disclaims any and all liability, including without limitation special, consequential or incidental damages. "Typical" parameters which may be provided in SCILLC data sheets and/or specifications can and do vary in different applications and actual performance may vary over time. All operating parameters, including "Typicals" must be validated for each customer application by customer's technical experts. SCILLC does not convey any license under its patent rights nor the rights of others. SCILLC products are not designed, intended, or authorized for use as components in systems intended for surgical implant into the body, or other applications intended to support or sustain life, or for any other application in which the failure of the SCILLC product could create a situation where personal injury or death may occur. Should Buyer purchase or use SCILLC products for any such unintended or unauthorized application, Buyer shall indemnify and hold SCILLC and its officers, employees, subsidiaries, affiliates, and distributors harmless against all claims, costs, damages, and expenses, and reasonable attorney fees arising out of, directly or indirectly, any claim of personal injury or death associated with such unintended or unauthorized use, even if such claim alleges that SCILLC was negligent regarding the design or manufacture of the part. SCILLC is an Equal Opportunity/Affirmative Action Employer. This literature is subject to all applicable copyright laws and is not for resale in any manner.

## PUBLICATION ORDERING INFORMATION

### LITERATURE FULFILLMENT:

Literature Distribution Center for ON Semiconductor  
P.O. Box 5163, Denver, Colorado 80217 USA

**Phone:** 303-675-2175 or 800-344-3860 Toll Free USA/Canada

**Fax:** 303-675-2176 or 800-344-3867 Toll Free USA/Canada

**Email:** [orderlit@onsemi.com](mailto:orderlit@onsemi.com)

**N. American Technical Support:** 800-282-9855 Toll Free  
USA/Canada

**Japan:** ON Semiconductor, Japan Customer Focus Center  
2-9-1 Kamimeguro, Meguro-ku, Tokyo, Japan 153-0051  
**Phone:** 81-3-5773-3850

**ON Semiconductor Website:** <http://onsemi.com>

**Order Literature:** <http://www.onsemi.com/litorder>

For additional information, please contact your  
local Sales Representative.