



**ON Semiconductor**  
Formerly a Division of Motorola  
<http://onsemi.com>

## Characterization of Retrigger Time in the HC4538A Dual Precision Monostable Multivibrator

Prepared by: Douglas M. Buzard, Rodolfo E. Soto

### Introduction

The MC74HC4538A is a monostable multivibrator commonly used as a one-shot, or in applications that require a pulse width of reliable dimensions. The pulse width and the minimum retrigger time are usually well behaved over the suggested pulse-width range of 1 $\mu$ s to 1 second. However, some customers have found that in using shorter than recommended pulse widths the retrigger time did not behave as it had at longer pulse widths. ON Semiconductor has done an overall characterization of the minimum retrigger time in an investigation of this phenomenon.

The retrigger time is applicable when the device is triggered a second time within the period of the output pulse. When this happens, the output pulse remains high for a period of  $\tau + T_{rr}$ . The earliest the part can be retriggered, or the minimum retrigger time, is the focus of this characterization. A trigger pulse on A or B inputs before this minimum retrigger time would be ignored.

### Analysis and Data

When used in the retriggerable mode (Figure 1), the MC74HC4538A uses an external  $R_x$  &  $C_x$  to regulate the output pulse width, and the minimum retrigger time ( $T_{rr}$ ). The minimum retrigger time depends on:

- 1) Time to discharge  $R_x C_x$  from  $V_{CC}$  to ( $V_{ref\ lower} = 1/3 V_{CC}$ )  $T_{discharge}$ . This discharge occurs quickly because external resistance,  $R_x$ , does not have any effect on the  $R_C$  time constant. The resistance in the discharge path, as seen in Figure 2, is the on-resistance of M3, and the interconnect resistance. The interconnection resistance is dependent on the polysilicon sheet resistance, the metal sheet

### APPLICATION NOTE

resistance, and the contact resistance. The interconnection resistance is heavily process dependent, but fortunately it is small overall and doesn't vary significantly from lot to lot.

The discharge time can be computed from:

$$T_{discharge} = \left( \ln \frac{3}{2} \right) \cdot R_i \cdot C_x$$

(Equation 1)

Typically the value of  $R_i$  would be near 300 $\Omega$ .

- 2) Loop delay ( $T_{delay} = \text{constant}$ ) ranges from 20–60ns, and is strongly correlated to  $V_{CC}$ . This is the time for the signal coming from the lower reference circuit to reset the flip-flop, and turn off M3. The amount of the undershoot voltage is a function of the loop delay, and for small values of capacitance the undershoot voltage is well below the lower reference voltage.
- 3) The time to charge  $R_x C_x$  from the undershoot voltage back to the lower reference voltage ( $V_{ref\ lower}$ ). This time is given by the  $R_x C_x$  transient equation:

$$T_{charge} = R_x \cdot C_x \cdot \ln \left( 1 + \frac{3 \cdot V_{undershoot}}{2 \cdot V_{CC}} \right)$$

(Equation 2)

where  $V_{undershoot} = (V_{ref\ lower}) - Gnd$ . Hence the retrigger time is given by:

$$T_{rr} = T_{discharge} + T_{delay} + T_{charge}$$

(Equation 3)

# AN1558/D

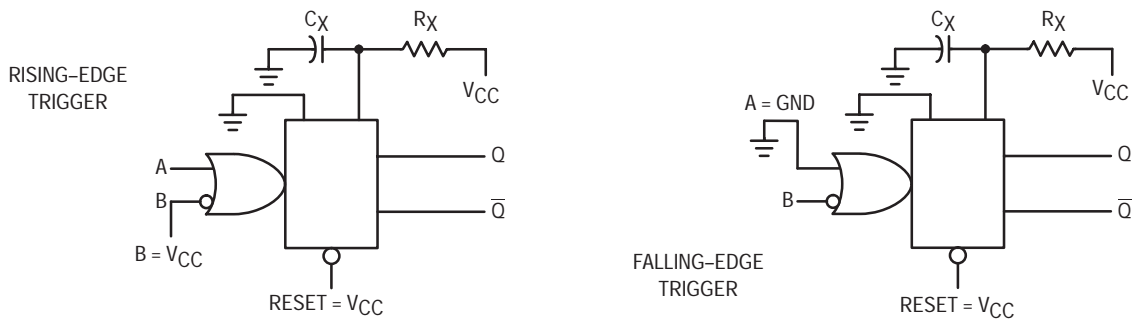

Figure 1. Retriggerable Monostable Circuitry

## LOGIC DETAIL (1/2 THE DEVICE)

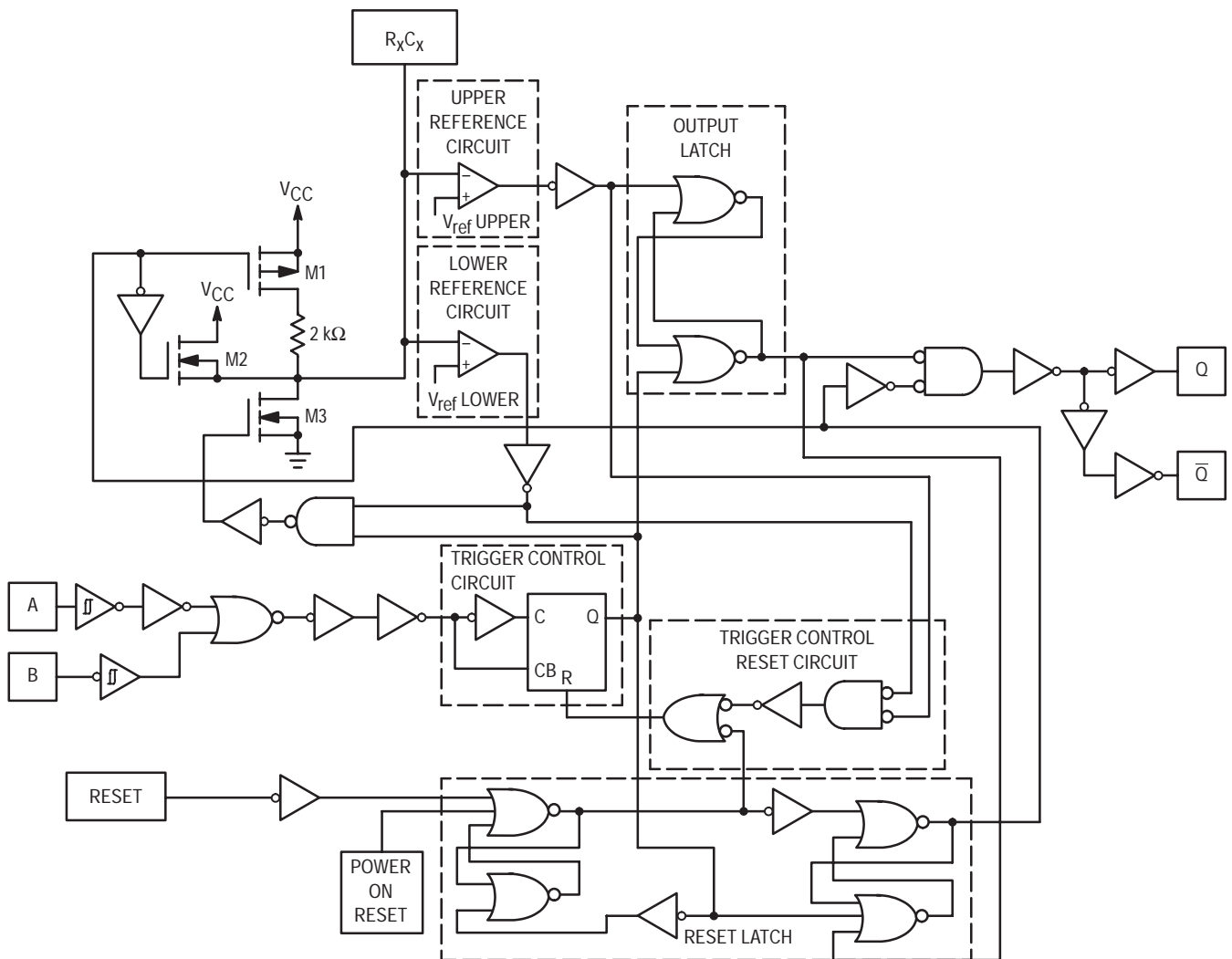

Figure 2. MC74HC4538A Logic Circuit Detail

# AN1558/D

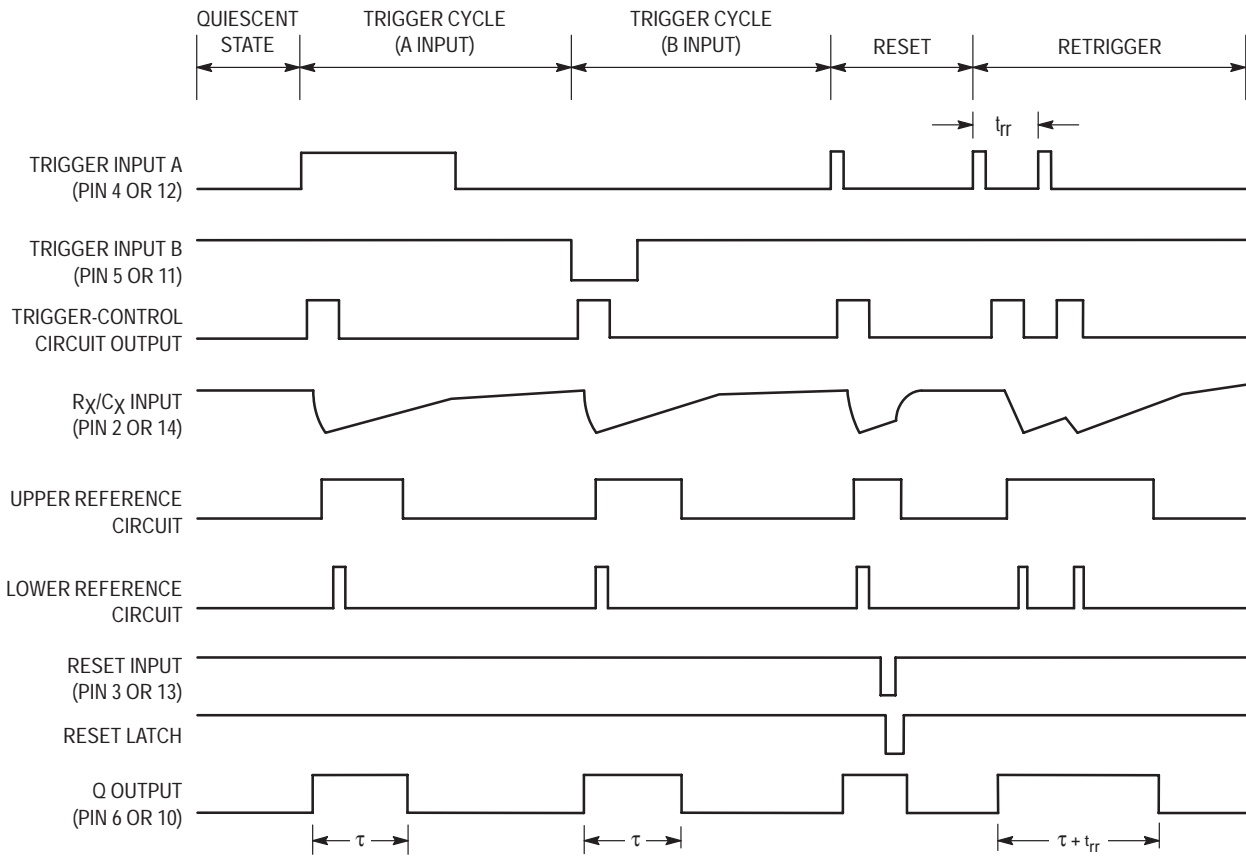

Figure 3. Timing Diagram

## Design and Applications

The output pulse width of the HC4538A is determined by the external timing components,  $R_X$  and  $C_X$ , and can be represented linearly as shown in Figure 10.

The array in Table 1 was generated to make a concise study of the behavior for the retrigger time for short pulse widths. A sample of 10 pieces from each of 7 non-consecutive wafer lots were tested at each condition.

The retrigger time for external capacitance that ranges from  $3000\text{pF} < C_X < 4.7\mu\text{F}$ , Region 3 on the graphs, can be computed by making use of the following linear equation (Equation 4).

$$T_{rr} = 10^z,$$

$$\text{where } z = \left[ -1062.41 - (0.1236764 \cdot V_{CC}) + (1.13509292 \cdot (\text{Log } C_X)^3) - (2.875 \times 10^{-17} \cdot R_X^3) + \right. \\ (3.5256 \times 10^{-16} \cdot (\text{Log } C_X)^2 \cdot R_X) + (5.9621 \times 10^{-12} \cdot (\text{Log } C_X) \cdot R_X^2) + (4.03306325 \cdot (\text{Log } C_X)^2) + \\ (7.9452 \times 10^{-11} \cdot R_X^2) + (5.1513 \times 10^{-5} \cdot (\text{Log } C_X) \cdot R_X) + (0.02312176 \cdot \text{Log } R_X) + \\ \left. (1.8339 \times 10^{-4} \cdot R_X) - (171.91718 \cdot \text{Log } C_X) + (4.64784302 \times 10^8 \cdot C_X) \right]$$

Equation 4. Retrigger Time for  $4.7\mu\text{F} > C_X > 3000\text{pF}$

Table 1. Test Matrix

$C_X/R_X$	10pF	100pF	220pF	1000pF
2KΩ	4.5V	4.5V	4.5V	4.5V
10KΩ	3.0V 4.5V	3.0V 4.5V	3.0V 4.5V	3.0V 4.5V
100KΩ	3.0V 4.5V	3.0V 4.5V	3.0V 4.5V	3.0V 4.5V
1MΩ	3.0V 4.5V	3.0V 4.5V	3.0V 4.5V	3.0V 4.5V

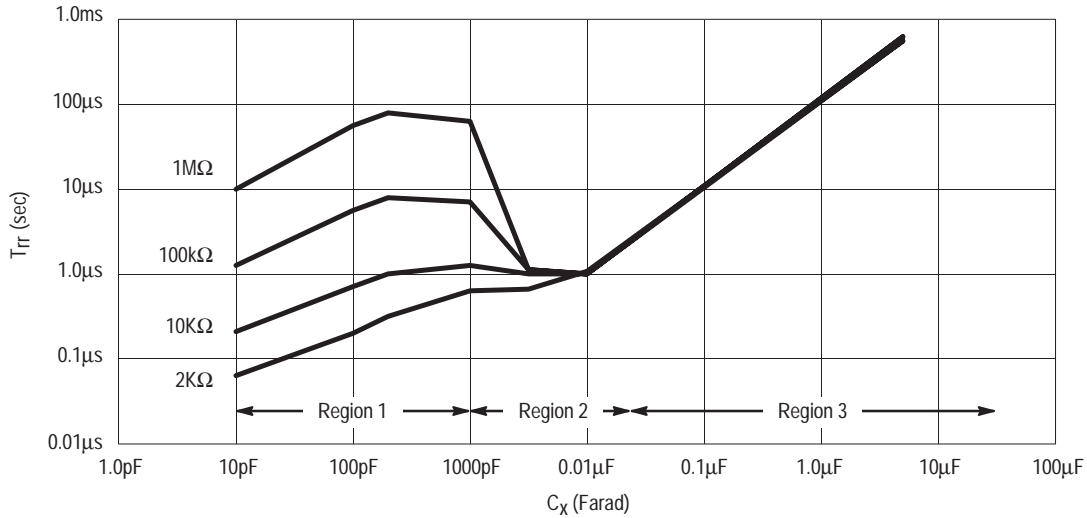

Figure 4. Retrigger Time versus Timing Capacitance at  $V_{CC} = 4.5V$

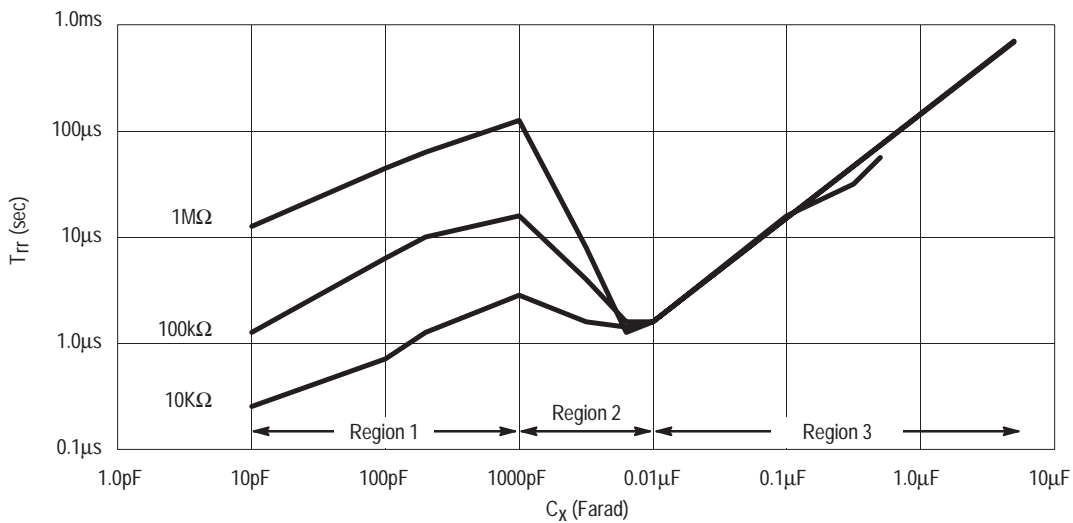

Figure 5. Retrigger Time versus Timing Capacitance at  $V_{CC} = 3.0V$

For values of  $1000pF < C_x < 3000pF$ , the non-linear portion of the curves are converging. In this region, Region 2, the equation was represented by too few measurements to generate a reasonably accurate equation. Therefore, the equation in Region 2 will remain underived. A value may be approximated from the graphs in Figure 4 and Figure 5.

It was determined from experiment and statistical analysis of the data that the retrigger time for small values of external capacitance within the range of  $10pF < C_x < 1000pF$ , Region 1, can be characterized with the following linear equation (Equation 5).

$$T_{rr} = 10^z,$$

$$\text{where } z = \left[ -315.29624 - (0.082881 \cdot V_{CC}) - (0.3146338 \cdot (\text{Log } C_X)^3) + 4.3277 \times 10^{-16} \cdot R_X^3 \right] - \\ (3.984 \times 10^{-7} \cdot (\text{Log } C_X)^2 \cdot R_X) + (3.0657 \times 10^{-12} \cdot (\text{Log } C_X) \cdot R_X^2) - (9.467093 \cdot (\text{Log } C_X)^2) - \\ (4.575 \times 10^{-10} \cdot R_X^2) - (1.124 \times 10^{-5} \cdot (\text{Log } C_X) \cdot R_X) - (94.092747 \cdot \text{Log } C_X) + \\ (1.36599588 \times 10^8 \cdot C_X) - (1.423 \times 10^{-5} \cdot R_X) \left] \right.$$

#### Equation 5. Retrigger Time for 10pF < C<sub>X</sub> < 1000pF

Here, the same components of:

$$T_{rr} = T_{\text{discharge}} + T_{\text{delay}} + T_{\text{charge}}$$

(Equation 3)

are still represented, but have become combined by the linear regression. The constant and V<sub>CC</sub> dependent term still derive from the loop delay, and serve to shift the components along the vertical axis. The major difference between this and the larger values of C<sub>X</sub> is twofold.

First, over all of Region 3 the undershoot is effectively 0 volts. This results in T<sub>charge</sub> not contributing to T<sub>rr</sub> and the predictable minimum T<sub>rr</sub> occurring in Region 2.

Second, as we progress to smaller values of capacitance in Region 1, C<sub>X</sub> is too small to support V<sub>reflower</sub> as the charge is drained through M3. This is why the resistance of R<sub>X</sub> now plays a role in T<sub>rr</sub>. This condition creates the undershoot of V<sub>reflower</sub> and the time of T<sub>charge</sub> is then controlled by the current through R<sub>X</sub>. This is also why as the

value of C<sub>X</sub> increases for the same resistance, T<sub>rr</sub> increases as it takes longer to charge the larger capacitor. For values of R<sub>X</sub> > 10kΩ, this increasing undershoot of V<sub>reflower</sub> and the resultant increase in T<sub>charge</sub> negates any improvement in T<sub>rr</sub>.

At small values of C<sub>X</sub>, the circuit capacitance will also come into play. The size of the undershoot of V<sub>reflower</sub> can vary as a function of normal process variance. This will also introduce an uncertainty into T<sub>rr</sub> for these smaller values. The curves and regression equations here were derived statistically and only represent the mean of the variance in 7 non-consecutive production lots.

This difference in the non-zero value of T<sub>charge</sub> in Region 1 can also be seen in Figure 6 and Figure 7 as the slope of T<sub>rr</sub> becomes zero as the undershoot becomes zero.

Also, note that in Figure 8 through Figure 11, this effect has no influence on the Output Pulse Width as the Pulse Width is controlled by R<sub>X</sub>C<sub>X</sub> and V<sub>refupper</sub>.

$$\tau = 10^z,$$

$$\text{where } z = \left[ -1.0059363 - (7.6336 \times 10^{-3} \cdot V_{CC}) + (0.87653815 \cdot \text{Log } R_X) + \right. \\ \left. (0.8635535 \cdot \text{Log } C_X) - (9.3203 \times 10^{-3} \cdot \text{Log } R_X \cdot \text{Log } C_X) \right]$$

#### Equation 6. Pulse Width

Equation 6 is a linear regression equation for calculating the pulse width and is also made from the data means. From the logarithmic plots in Figure 8 through Figure 11, it can be seen that there is no cubic dependency similar to T<sub>rr</sub>, even at the small values of capacitance. The pulse width is completely controlled by the relationship between R<sub>X</sub>C<sub>X</sub> and V<sub>refupper</sub>. This predictability of the pulse width has tempted some customers into trying to use the part for very short pulse widths. Unfortunately it has also resulted in inconsistent performance for T<sub>rr</sub>.

#### Summary

While smaller pulse widths and T<sub>rr</sub> values can be achieved, selection of the external components must take into account the introduction of undershoot of V<sub>reflower</sub>.

Also, as we have stated above, as the value of C<sub>X</sub> decreases in the non-linear region, the total capacitance becomes more dependent upon internal circuit capacitance. Since the internal circuit capacitance is process dependent, it can vary from lot to lot, and from manufacturing site to manufacturing site. It is for this reason that the device is not recommended to be used in this range, as doing so would potentially result in inconsistent performance over large production runs. The curves represented in this applications note were made using linear regression on a number of lots widely separated in time, but all from the same manufacturing site. As a result, the curves can only be regarded as statistical means, and may not represent the performance of any particular device the customer may encounter.

# AN1558/D

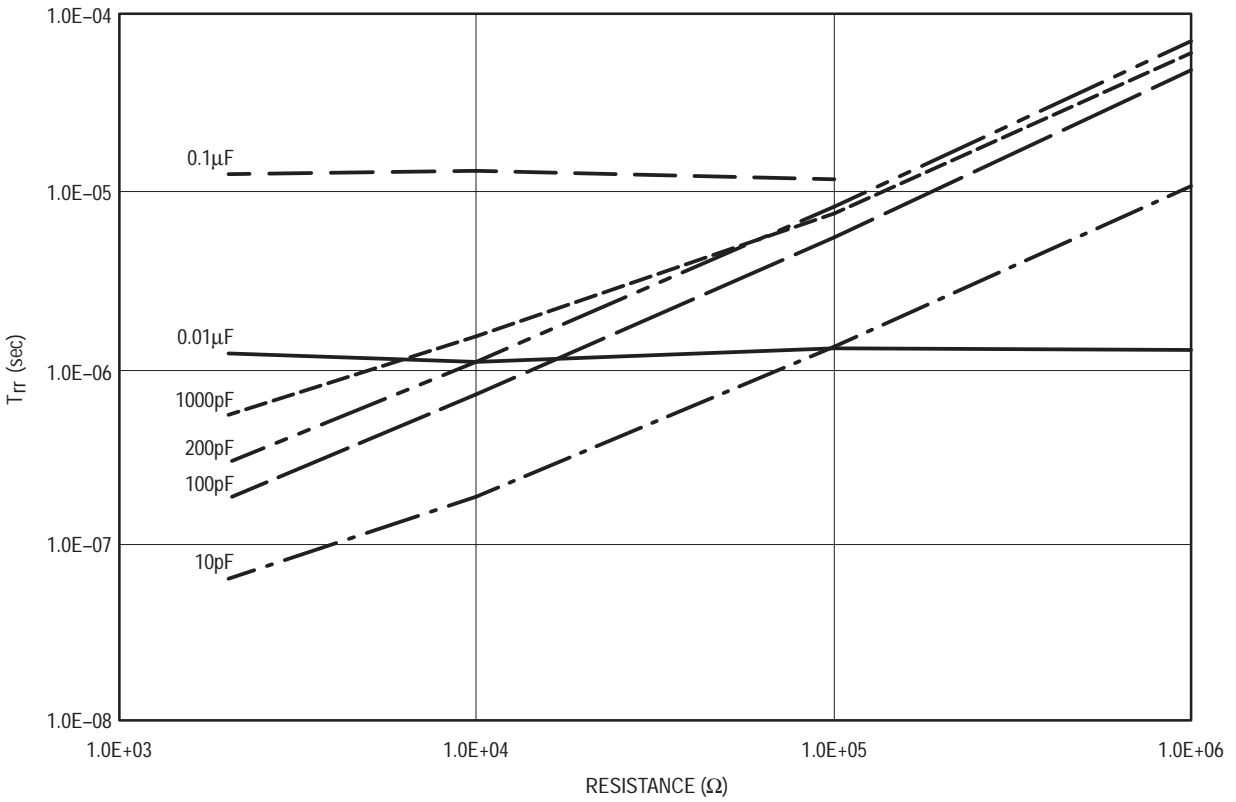

Figure 6. Retrigger Time vs Resistance at  $V_{CC} = 4.5V$

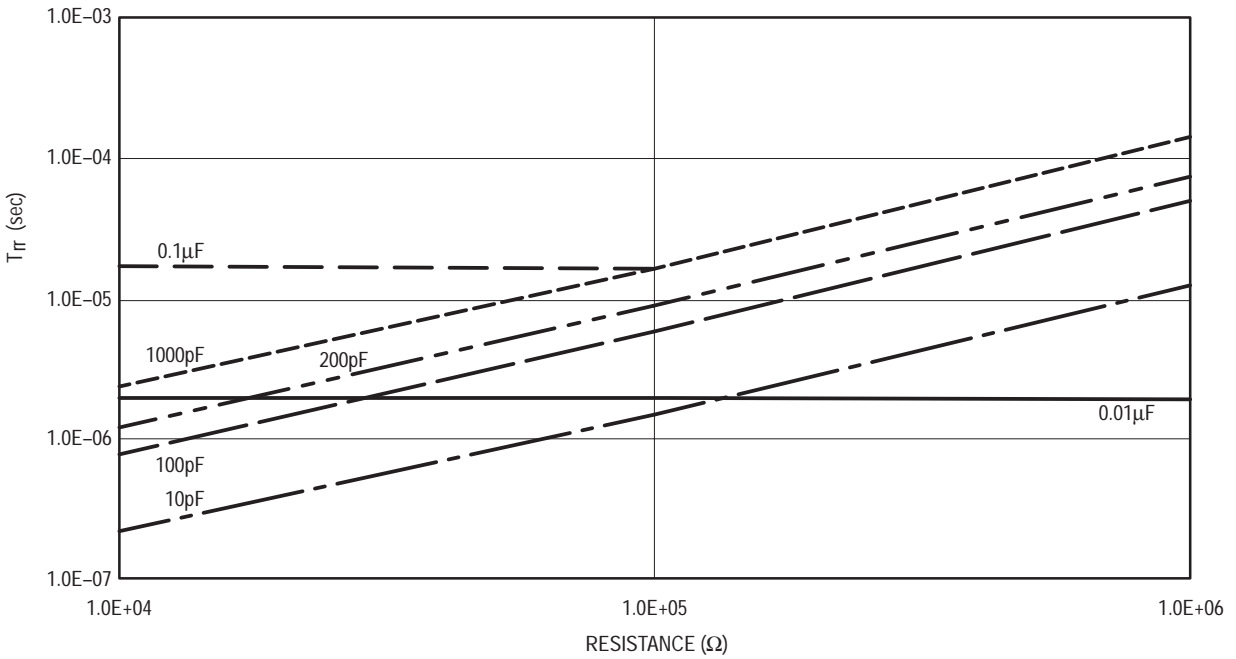

Figure 7. Retrigger Time vs Resistance at  $V_{CC} = 3.0V$

# AN1558/D

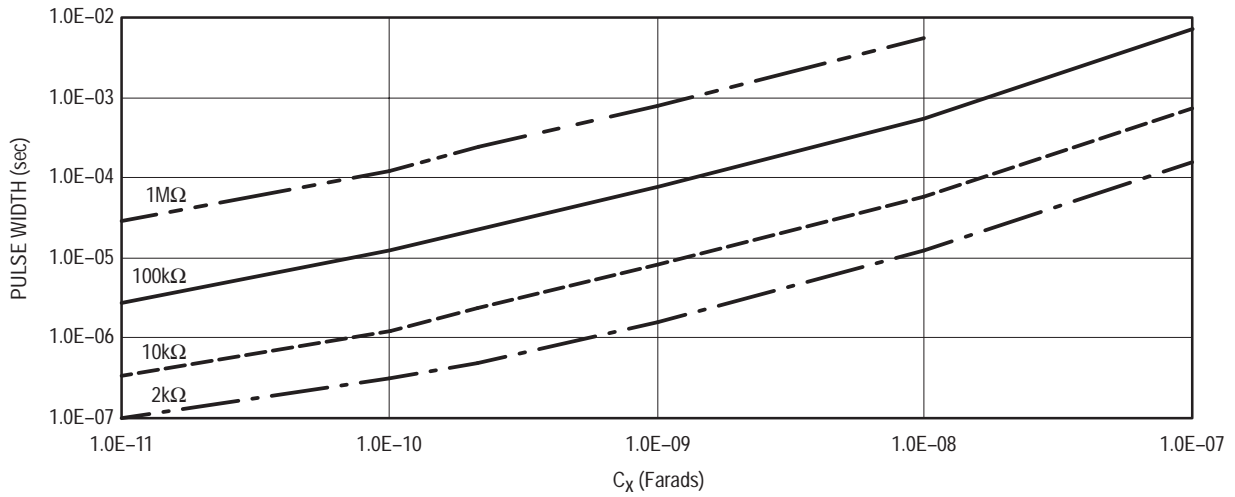

Figure 8. Pulse Width vs Timing Capacitance at  $V_{CC} = 4.5V$

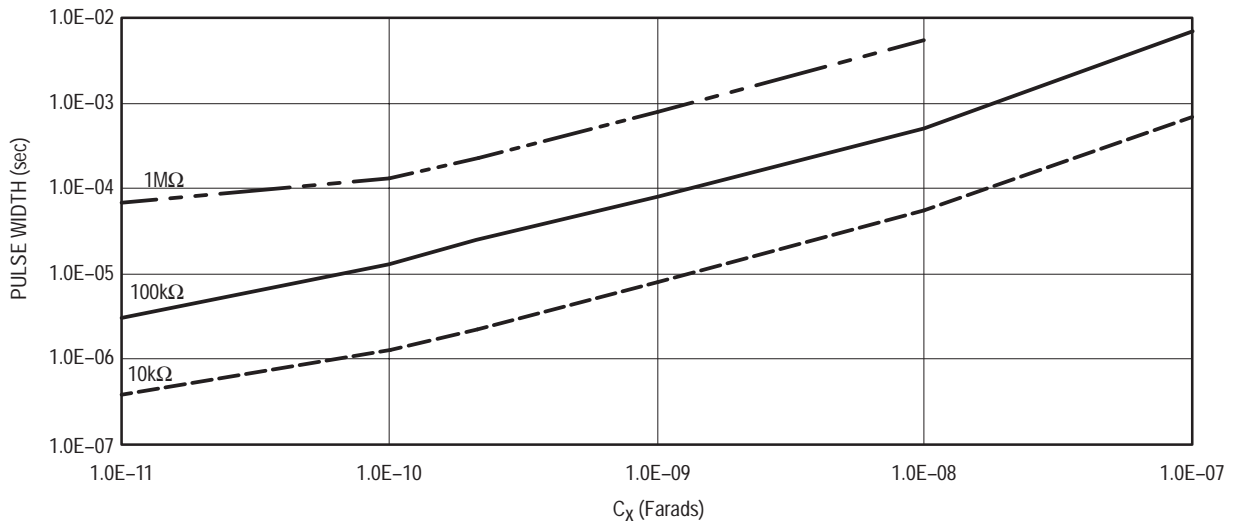

Figure 9. Pulse Width vs Timing Capacitance at  $V_{CC} = 3.0V$

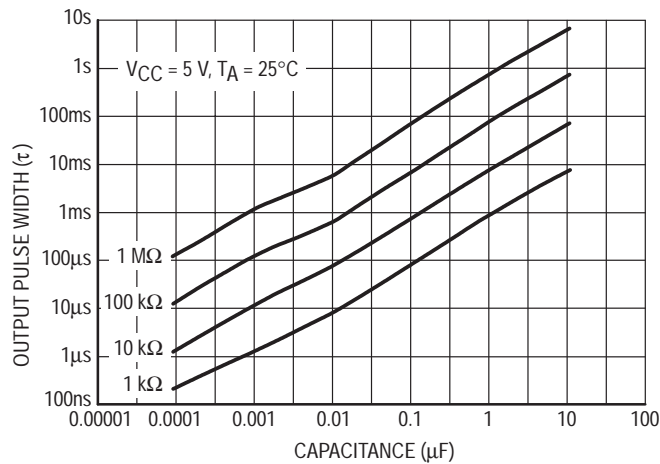

Figure 10. Output Pulse Width vs Timing Capacitance

# AN1558/D

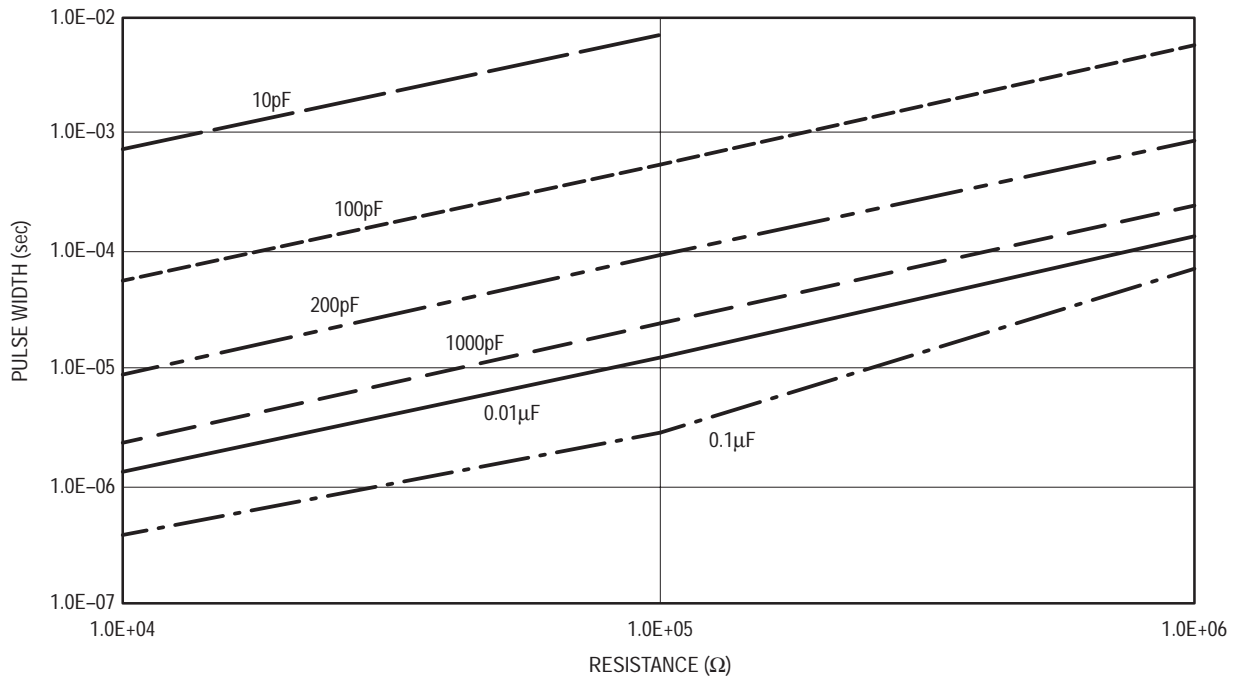

Figure 11. Pulse Width versus Resistance at  $V_{CC} = 3.0V$

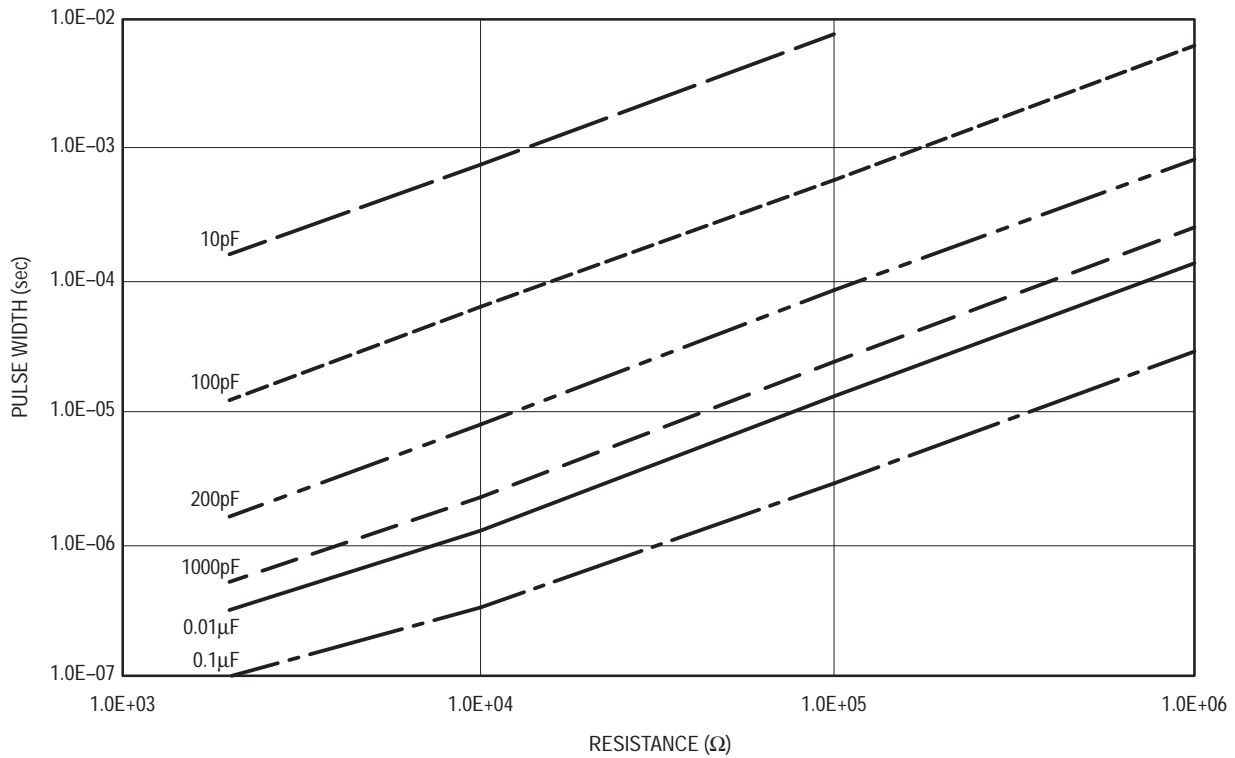



Figure 12. Pulse Width versus Resistance at  $V_{CC} = 4.5V$

## Notes

## Notes

## Notes

**ON Semiconductor** and  are trademarks of Semiconductor Components Industries, LLC (SCILLC). SCILLC reserves the right to make changes without further notice to any products herein. SCILLC makes no warranty, representation or guarantee regarding the suitability of its products for any particular purpose, nor does SCILLC assume any liability arising out of the application or use of any product or circuit, and specifically disclaims any and all liability, including without limitation special, consequential or incidental damages. "Typical" parameters which may be provided in SCILLC data sheets and/or specifications can and do vary in different applications and actual performance may vary over time. All operating parameters, including "Typicals" must be validated for each customer application by customer's technical experts. SCILLC does not convey any license under its patent rights nor the rights of others. SCILLC products are not designed, intended, or authorized for use as components in systems intended for surgical implant into the body, or other applications intended to support or sustain life, or for any other application in which the failure of the SCILLC product could create a situation where personal injury or death may occur. Should Buyer purchase or use SCILLC products for any such unintended or unauthorized application, Buyer shall indemnify and hold SCILLC and its officers, employees, subsidiaries, affiliates, and distributors harmless against all claims, costs, damages, and expenses, and reasonable attorney fees arising out of, directly or indirectly, any claim of personal injury or death associated with such unintended or unauthorized use, even if such claim alleges that SCILLC was negligent regarding the design or manufacture of the part. SCILLC is an Equal Opportunity/Affirmative Action Employer.

## PUBLICATION ORDERING INFORMATION

### NORTH AMERICA Literature Fulfillment:

Literature Distribution Center for ON Semiconductor  
P.O. Box 5163, Denver, Colorado 80217 USA  
**Phone:** 303-675-2175 or 800-344-3860 Toll Free USA/Canada  
**Fax:** 303-675-2176 or 800-344-3867 Toll Free USA/Canada  
**Email:** ONlit@hibbertco.com  
Fax Response Line: 303-675-2167 or 800-344-3810 Toll Free USA/Canada

**N. American Technical Support:** 800-282-9855 Toll Free USA/Canada

**EUROPE:** LDC for ON Semiconductor – European Support

**German Phone:** (+1) 303-308-7140 (M-F 1:00pm to 5:00pm Munich Time)  
**Email:** ONlit-german@hibbertco.com  
**French Phone:** (+1) 303-308-7141 (M-F 1:00pm to 5:00pm Toulouse Time)  
**Email:** ONlit-french@hibbertco.com  
**English Phone:** (+1) 303-308-7142 (M-F 12:00pm to 5:00pm UK Time)  
**Email:** ONlit@hibbertco.com

**EUROPEAN TOLL-FREE ACCESS\*: 00-800-4422-3781**

\*Available from Germany, France, Italy, England, Ireland

### CENTRAL/SOUTH AMERICA:

**Spanish Phone:** 303-308-7143 (Mon-Fri 8:00am to 5:00pm MST)  
**Email:** ONlit-spanish@hibbertco.com

**ASIA/PACIFIC:** LDC for ON Semiconductor – Asia Support

**Phone:** 303-675-2121 (Tue-Fri 9:00am to 1:00pm, Hong Kong Time)  
Toll Free from Hong Kong & Singapore:  
**001-800-4422-3781**  
**Email:** ONlit-asia@hibbertco.com

**JAPAN:** ON Semiconductor, Japan Customer Focus Center  
4-32-1 Nishi-Gotanda, Shinagawa-ku, Tokyo, Japan 141-8549

**Phone:** 81-3-5740-2745  
**Email:** r14525@onsemi.com

**ON Semiconductor Website:** <http://onsemi.com>

For additional information, please contact your local Sales Representative.